



# **UTTAR PRADESH JAL NIGAM (URBAN)**

## **TENDER DOCUMENT ON TURNKEY BASIS**

### **FOR THE WORK OF**

Re-Organization of Nagar Panchayat Mau Aima Water Supply Scheme in

District- Prayagraj

Under

AMRUT 2.0

**NIT No. : 322 / AMRUT 2.0 / 273 Dated 08.05.2026**

Superintending Engineer  
Construction Circle  
U P Jal Nigam (Urban)  
Prayagraj

## TABLE OF CONTENTS

Sl. No.	Section	Description	Pages	
			From	To
1	<b>Section-1</b>	Tender Notice		
2		Important Dates		
3	<b>Section-2, Chapter-1</b>	Brief Particulars of Work		
4	Chapter-2	Instruction to Bidders		
5	Chapter-3	Eligibility Criteria		
6	Chapter-4	Evaluation and Qualification Procedure		
7	Chapter-5	Preparation & Submission of e-Bids		
8	<b>Section-3</b>	Check list required for submission of documents, Annexure-1		
9		Integrity Pact, Annexure-2		
10		Form of Joint Bidding Agreement, Annexure-3		
11		Form of POA for Lead Partner, Annexure-4		
12		Form of POA for Authorized Signatory, Annexure-5		
13		Form of BG for Bid Security/EMD, Annexure-6		
14		General Information, Form-I		
15		Form for Earnest Money, 1-A		
16		Affidavit for Bid Validity 1-B		
17		Standard Affidavit 1-C		
18		Financial Information, Form-II A		
19		Format for Solvency Certificate, Form II-B		
20		Detail of similar type of work, Form-III & IIIA		
21		Format for Information on works in hand, Form-IV		
22		Personnel Capabilities Form-V		
23		Format for Experience Certificate. Form-VI		
24		Equipment Capabilities, Form-VII		
25		Litigation History, Form-VIII		
26		Letter of Comprising Bid, Form-IX		
27	<b>Section-4 Part-I</b>	General Conditions of Contract		
28		Appendix to General Conditions of Contract		
29	Part-II	Special Conditions of Contract		
30	<b>Section-5</b>	TECHNICAL SPECIFICATIONS		
31		List of Preferred Makes		
32	<b>Section-6</b>	Schedule-A to Schedule-J		

Sl. No.	Section	Description	Pages	
			From	To
33	<b>Section-7</b>	Standard Form of Agreement.		
34		Form for BG against Performance Security, Annexure-7		
35		Form of Indenture for Secured Advance, Annexure-8		
36		Form of BG against Mobilization Advance		
37	<b>Drawing</b>			



Email - se.ccpvj@gmail.com  
Mo.No.+919473942672

# उत्तर प्रदेश जल निगम (नगरीय)

कार्यालय अधीक्षण अभियन्ता, निर्माण मण्डल, नैनी, प्रयागराज-211007

पत्रांक:- 322 / अमृत 2.0 / 273 दिनांक:- 08 / 05 / 2026

## SHORT TERM E-TENDER NOTICE

On behalf of the Chairman, U.P. Jal Nigam (Urban) online e-tenders on percentage rate basis in two bid system for following works under AMRUT 2.0 Programme are hereby **Re-invited (Second time)** on turnkey basis from the reputed contractors having requisite work experience & financial capabilities. The bidders should submit their bids only if they consider themselves eligible and are in possession of all the requisite documents.

S. N.	Description of work & Location	Estimated cost of work put to bid in lacs (excluding GST & including Labour Cess)	Earnest Money (Rs. In Lacs)	Cost of bid document	Period of completion	Last Date & time of submission of bid as specified in the bid documents	Time, date & Place of opening of Pre-qualification Cum Technical Bid
1	Survey, Soil Investigation, Design, Supply of all materials, labour, T&P etc. Required for Construction/Repairing, Erection, Testing And Commissioning of Water Supply Works Such RCC Over Head Tank, Pump house, Staff quarter, Boundary wall, Gate, Site development, renovation of Existing facilities including laying & jointing of rising main/Distribution System, providing Functional Water supply house Connections, construction of tube wells including SCADA automation and other appurtenant works of "Re-Organization of Nagar Panchayat Mau Aima Water Supply Scheme District-Prayagraj under AMRUT 2.0 Programme" on Turnkey basis as specified in Tender Document. The scope of works also includes trial and run of 3 month and defect	Rs. 2057.63 Lacs	Rs. 20.58 Lacs	Rs. 20000.00 + 18% GST = Rs. 23600.00	18 Months (Including Rainy season & 03 months Trial & Run period). Defect liability period will be for 12 months for Civil work & 24 Months for E&M work which will start after completion of trial run period.	Upto 01.06.2026 Till 17:00 Hrs	On 02.06.2026 At 11:00 Hrs office of the Superintending Engineer, Construction Circle, U.P. Jal Nigam (Urban), Prayagraj

liability period of 12 months for civil works and 24 months for E&M works after completion of successful trial and run. All completed and commissioned works of above scheme shall be handed over to Nagar Panchayat Mau Aima ,District - Prayagraj after 3 months of successful trial run period.						
--	--	--	--	--	--	--

The Bid document may be downloaded from "<https://etender.up.nic.in>" w.e.f dated 11.05.2026.

1. Pre bid meeting date, time & venue: - 18.05.2026 at 11:00 AM in office of the Superintending Engineer, Construction Circle, U.P. Jal Nigam(Urban), Prayagraj.
2. The Bid should be valid for 120 days from the last date of submission of bids.
3. If the date of opening of technical bid happens to be a holiday, the bid shall be opened on the next working day at the same time **for which no separate communication shall be sent.**
4. Bidders having criminal record will not be allowed to participate in Bid process.
5. A person registered with any State Bar Council will not be eligible to participate in the Bid.
6. As per Government norms GST at Applicable rate will be paid extra.
7. **Joint Venture:-Eligibility for JV/Consortium-**
  - The Joint Venture is allowed with maximum two member out of which lead member has to be an Indian firm/company. Foreign companies can be part of Joint Venture.
  - The lead Member of the JV/consortium must have minimum 51% of the stake Holding.Member of Joint venture, other than the lead member, should have at least 30% Satake Holding.
  - Lead member should have a turnover of at least 51% of the total turnover required.
  - Lead member should have a Solvency of at least 51% of the total Solvency required.
  - **Project costing ≤ 10 Cr.-** JV/consortium shall have the required technical experience collectively.
  - **Project costing >10 Cr. - Upto 25 cr. -** Lead member of JV/consortium should have at least 30% technical experience of required technical experience.
  - **Project costing > 25 Cr. -** Both members of JV/consortium should have at least 30% technical experience of required technical experience.
  - A member of JV/Consortium shall not participate either in individual capacity or as a member of another JV/consortium in the same tender.
  - Tender form shall only be submitted in the name of the JV/consortium. Tender fees maybe submitted by lead partner/JV.
  - A single Performance Guarantee shall be submitted by the JV/Consortium in the name of the JV/Consortium.
  - **Tender for more than 05 Projects of AMRUT 2.0 will not be allotted to any firm as JV Partner at any time. If a firm is allotted 05 Tenders as JV**

Partner, then that firm will not be able to participate in any tender as JV until one of the works of the allotted 05 Tenders is finished and completion certificate have been issued by the concerned office. The above condition will not apply for individual participation in the tender.

- All the member of the JV/consortium of Bidders shall be liable jointly and severally for the execution of the project.

#### 8. Eligibility:-

(a) Contractors who inter-alia fulfill the following requirements shall be eligible to apply. Firm should have successfully completed, Tested and commissioned similar works (**Similar work shall mean "Completed, Tested and Commissioned Works of Piped Water Supply scheme and its associated infrastructure works.**) mentioned below during last Ten years as on date of publication of NIT, satisfying followings:-

(i) Three Completed, Tested and Commissioned works each costing not less than the amount equal to 30% or more of the estimated cost put to tender (i.e. Rs. **617.29 lacs**).

Or

(ii) Two Completed, Tested and Commissioned works each costing not less than the amount equal to 40% or more of the estimated cost put to tender (i.e. Rs. **823.05 lacs**).

Or

(iii) One Completed Tested and commissioned work each costing not less than the amount equal to 60% or more of the estimated cost put to tender (i.e. Rs **1234.58 lacs**).

**Particular Condition :- The experience must include one work of 2/3rd size (i.e. 350 mm x 2/3 = 250 mm Dia) of maximum diameter mentioned in BOQ of this NIT for a minimum length of 500 meters.**

#### Note:-

(i) The Bidder should have experience of work Contract including testing and commissioning successfully in last 10 years as on date of publication of NIT.

(ii) In Case of Turn Key projects experience of works/components put to tender namely OHT , Tubewell , Distribution Networks for water supply project will also be considered accordingly.

(iii) The Experience in Foreign countries of a subsidiary or parent company will also be considered for qualification. In Case the company is not registered in India the experience has to be certified by the respective Embassy office/Apostille (in case of members of Hague Apostille Convention )

(iv) The works Like SCADA/Automation /I.T. Solutions and Construction of Electric Sub-Station can be sourced /sub- contracted to other firms after approval of Engineer – in – Charge , but the main Contractor will be responsible for the quality of work and its timely Completion.

(v) Sub-contracting / subletting experience shall be considered valid only if the Experience certificate is directly issued to the sub-contractor by the department and work Experience provides all relevant information and supported by relevant documents like 26 AS, a proof of payment received from the client.

(vi) The certificates should be certified by an officer not below the rank of Executive Engineer/Project Manager or equivalent. All the performance certificates submitted should be clear and exhaustive enough to establish similarity with the work under Bid. Ambiguous Performance Certificates will not be considered for evaluation.

(b) **Turn Over :-** Should have average **audited** annual financial turnover during immediate last 3 (three) consecutive financial years on construction works, equal to at least **30%** of the cost of

work put to tender, i.e. Rs. 617.29 lacs. Any Year in which no turnover is shown will also be considered for working out the average.

(c) **Net Worth :-** The bidder must have a positive net worth in the immediate last financial year and same should be certified by Statutory Auditor. Further, net worth of all the partners in a JV should individually be positive. At the time of Submission of bid, contractor has to upload certificate from statutory auditor of the firm mentioning year wise audited financial turnover on Construction Works of last 05 years. Further details, if required may be asked from the contractor after opening of technical bids.

(d) **Solvency Certificate of minimum 40% of the tender value** i.e. Rs. 823.05 lacs will be required to be submitted. The bidder must maintain his solvency till completion of project.

- Solvency Certificate issued by any Scheduled Commercial Bank shall be accepted, which will be valid for a period of one year from the date of issue unless otherwise mentioned.

Or

- Solvency Certificate issued by District Magistrate will also be accepted, which will have a validity of one year from date of issue unless otherwise mentioned.

(e) The value of experience on construction works and turnover shall be brought to current costing level by enhancing the actual values of work at simple rate @ 7% per annum calculated from the date of completion to the date of publication of NIT. A typical index is given below.

Financial Year	Escalation/ Enhance factor
First Year	1.00
Second Year	1.07
Third Year	1.14
Fourth Year	1.21
Fifth Year	1.28

9. This NIT and other information/corrigenda/addenda and Instruction for bidders posted on website shall form part of bid document.
10. The quantities given in the Bill of Quantities are estimated and provisional, and are given to provide a common basis for bidding. These are liable to change up to any extent for which no claim except as provided under contract shall be admitted.
11. The bid document consisting of Technical (eligibility) bid & financial bids including specifications, the bills of quantities of various types of items to be executed and the set of terms and conditions of the contract to be complied with and other necessary document are available on "<https://e-tender.up.nic.in>".
12. The technical bid shall be opened first on due date and time as mentioned above. The time and date of opening of financial bid of contractors, qualifying the technical bid shall be communicated to them on a later date through e-tender portal/ website.
13. If the Bidder feels that technical credentials of his own or other Bidders have been wrongly evaluated/verified, he may raise **objections within 2 (two) working days** from the date of uploading of result. No requests/objections shall be entertained beyond above limit, else it may be treated as an obstruction in tender process and shall be dealt with accordingly.
14. U.P. Jal Nigam(Urban) reserves the right to reject any prospective application or to cancel entire bid process without assigning any reason whatsoever.
15. E-tender document fee is non-refundable. It shall be deposited in the account of *Executive Engineer, Construction Division (I), UP Jal Nigam(Urban), Prayagraj* only by RTGS/NEFT in *Union Bank of India, Chowk, Prayagraj, A/c No.- 394302010994456*,

**IFSC Code- UBIN0807095.**

**16. Earnest Money:**

- (a) EMD will be 2 % for works up to Rs 5.00 Cr. and 1 % or Rs 10.00 lacs whichever is higher for works above Rs 5.00 Cr.
  - (b) EMD should be paid through RTGS or in the form of FDR/ Bank Guarantee issued by any scheduled commercial Bank.
  - (c) This Bank Guarantee must be in the prescribed format given in Annexure-6 of tender document and it should be valid for 65 days beyond the validity period of Tender.
  - (d) In case of JV Earnest money may be submitted by lead partner/JV.
  - (e) The RTGS component of earnest money shall be deposited in the account of **Executive Engineer, Construction Division (I), UP Jal Nigam(Urban), Prayagraj** only by RTGS/NEFT in **Union Bank of India, Chowk, Prayagraj, A/c No.- 394302010994456, IFSC Code-UBIN0807095.**
  - (f) The bidder shall deposit tender fees and earnest money **separately** in account mentioned as above. Further he shall upload digitally signed copies of original receipts of bank showing clearly the above details and/or the Bank Guarantee.
  - (g) In case EMD is submitted in the form of Bank Guarantee/FDR, bidder should ensure that such **Original Bank Guarantee/FDR is mandatorily deposited in the office of Executive Engineer, Construction Division(I),Uttar Pradesh Jal Nigam(Urban), Prayagraj on or before the day of scheduled date (during office hours) of opening of Technical Bid**, either in person or by Speed Post. The liability for timely submission shall lie with the Bidder, U.P. Jal Nigam(Urban) shall not be responsible for delay on account of any reason whatsoever.
  - (h) It is made clear that Tender Fee and Earnest Money deposited in any other form besides as mentioned above sub-para shall render the bid non-responsive.
  - (i) In case of JV the EMD should be in the name/ from the account of JV or lead partner as specified in the JV agreement.
  - (j) EMD if submitted in the form of BG/FDR should be pledged only in the favour of Executive Engineer, Construction Division (I), Uttar Pradesh Jal Nigam(Urban), Prayagraj.
17. All the Bank Guarantees/FDR submitted towards EMD/Performance Security/Additional Performance Security should be verifiable and encashable from a branch situated in a city where the office of Divisional Officer is located.
18. All the documents as specified in the technical bid/eligibility bid document should be uploaded within the period of bid submission. U.P. Jal Nigam(Urban) will not be liable for incomplete/inaccurate/non-submission of bid for any reason whatsoever including technical reasons. It is made clear that separate submission of originals of any documents (except Bank Guarantee/FDR) other than scanning and uploading them, are not required, unless called for, after opening of financial bid.
19. The bid submission shall become invalid if:
- (i) The bidder is found ineligible.
  - (ii) The bidder does not upload all the documents as stipulated in the bid document.
  - (iii) If any discrepancy is noticed between uploaded documents and originals/hard copies submitted later.

- (iv) If subsequent to due date of submission of bid and/or after its submission bidder makes any further communication/ representation with regard to the bid (whether technical or financial) than otherwise called for by the undersigned as a clarification.
- (v) If a bidder does not quote any percentage above/below/par on the total amount of the tender or any section/sub head in percentage rate tender. Further the tender will not be considered as lowest bid.
- (vi) Conditional tenders or Tenders without e-tender document fee & earnest money or invalid earnest money shall be summarily rejected.

20.

Performance guarantee @ 10% of the Contract cost will have to be submitted at the time of signing the contract in the form of FDR/ Bank Guarantee from any scheduled commercial Bank. Alternatively on request of the Contractor /firm, 5% of the performance Guarantee will be accepted at the time of signing of contract and rest 5% may be deducted from the initial running bill in a single deduction or at the rate of minimum 10% of the gross bill amount of running bill. However, in any case whole amount of balance performance guarantee shall be deducted within one year.

Works for which the cost of the tender received is more than 10 % below the estimated cost of works, in such situation, the performance security for first 10% below shall be 10% thereafter, additional performance security @ 0.50 % for each 1% further below than 10 % shall be deposited by the firm in order to safeguard against contractor leaving the works.

21. The available bid Capacity of the bidder at the expected time of bidding shall be more than the total estimated cost of the work for which the tender is invited.

The available Bid Capacity shall be assessed using following formula:- Assessed Available Bid Capacity =  $2x AxN - B$  Where

A= Maximum turnover during the last five financial year (corrected to the current level of value )

N= Stipulated period of execution of the work for which the tender is invited in years

B= value of existing commitments to be completed during the execution period of bid .

The turnover shall be corrected to the current level of value by multiplying with the updation factor given elsewhere with NIT/ bid Document.

**Note- 1) The minimum Bid Capacity of each JV member must be in the ratio of their stake holding in JV and Sum of Bid Capacity of JV must be more or equal to required Bid Capacity.**

22. Intending Bidders are advised to inspect and examine the site and its surroundings and satisfy themselves before submitting their bids as to the nature of the ground and sub-soil (so far as is practicable), the form and nature of the site, the means of access to the site, the accommodation they may require and in general shall themselves obtain all necessary information as to risks, contingencies and other circumstance which may influence or affect their bid. A bidder shall be deemed to have full knowledge of the site, whether he inspects it or not, and no extra charge consequent to any misunderstanding or otherwise shall be allowed. The bidder shall be responsible for arranging and maintaining at his own cost all materials, tools & plans, water, electricity access, facilities for workers and all other services required for executing the work unless otherwise specifically provided for in the contract documents. Submission of a bid by a bidder implies that he has read this notice and all other contract documents and has made himself aware of the instructions, scope and specifications of the work to be done and local conditions and other factors

having a bearing on the execution of the work.

**Note:- Bidders will have to quote their rate inclusive of labour cess but without GST which shall be paid after submission of appropriate document /proof on actual basis.**

23. Canvassing whether directly or indirectly, in connection with bids is strictly prohibited and the bids submitted by the bidders who resort to canvassing will be liable for rejection & will be debarred from future tender in U P Jal Nigam(Urban).
24. The bidder shall not be permitted to bid for works under supervisory control of Superintending Engineer and Executive Engineer concerned who is responsible for execution of work, in which his near relative is posted. He shall also intimate the names of persons who are working with him in any capacity or are subsequently employed by him and who are near relatives to any officer in the U P Jal Nigam(Urban). Any breach of this condition by the contractor would render him, if empanelled with U P Jal Nigam(Urban), liable to be removed from the approved list of contractors of U P Jal Nigam(Urban) and make him liable for black listing.
25. No Engineer or other Gazetted Officer employed in Engineering or Administrative duties in an Engineering U.P. Department of the State Government /State Undertaking is allowed to work as a contractor for a period of two years after his retirement from Government service, without the prior permission of the Government of U.P. in writing. This contract is liable to be cancelled if either the contractor or any of his employees is found any time to be such a person who had not obtained the permission of the Government of U.P. as aforesaid before submission of the bid or engagement in the contractor's service.

(Sanjay Kumar Ranjan)  
Superintending Engineer

**Endt.- No & Date : As above.**

**Copy forwarded to the following for information and necessary action: -**

1. Managing Director, UP Jal Nigam (Urban), Lucknow
2. Chief Engineer (PPRBD), UP Jal Nigam (Urban), Lucknow
3. Chief Engineer (Nagar), UP Jal Nigam (Urban), 6, Rana Pratap Marg, Lucknow.
4. Chief Engineer (Prayagraj zone), UP Jal Nigam (Urban), Prayagraj.
5. District Magistrate, Prayagraj.
6. Public Relation Officer, UP Jal Nigam(urban), 6- Rana Pratap Marg, Lucknow along with 6 copies of brief version of tender notice for publishing the same in at least two National level News Papers (Hindi & English) on two consecutive days and for uploading the same on UPJN web site. (Encl. – As above in 6 set.)
7. Superintending Engineer, construction circle(E/M), U.P.Jal Nigam (Urban), Prayagraj.
8. Executive Engineer, EDP Cell, UP Jal Nigam (Urban), Lucknow for publishing on UPJN (Urban) website.
9. Executive Engineer, Construction Division(I), UP Jal Nigam (Urban), Prayagraj.
10. Executive Engineer, Construction Division(E&M), UP Jal Nigam (Urban), Prayagraj.
11. Executive Officer, Nagar Panchayat Mau Aima, Prayagraj.
12. Notice Board.

  
Superintending Engineer



Email - se.ccpvj@gmail.com  
Mo.No.+919473942672

# उत्तर प्रदेश जल निगम (नगरीय)

कार्यालय अधीक्षण अभियन्ता, निर्माण मण्डल, नैनी, प्रयागराज-211007

पत्रांक:- 322 / अमृत 2.0 / 273 दिनांक:- 08 / 05 / 2026

## **SHORT TERM E-TENDER NOTICE**

(Short description of the E-Tender Notice for publication in News papers)

On behalf of the Chairman, U.P. Jal Nigam (Urban) invites Online percentage plus/minus (+/-) rate e-tenders on Turn-key basis in Two bid system for *“Survey, Soil Investigation, Design, Supply of all materials, labour, T&P etc. Required for Construction/Repairing, Erection, Testing And Commissioning of Water Supply Works Such RCC Over Head Tank, Pump house, Staff quarter, Boundary wall, Gate, Site development, renovation of Existing facilities including laying & jointing of rising main/Distribution System, providing Functional Water supply house Connections, construction of tube wells including SCADA automation and other appurtenant works of “Re-Organization of Nagar Panchayat Mau Aima Water Supply Scheme District-Prayagraj under AMRUT 2.0 Programme”* are hereby **Re-invited (Second time)** from eligible, reputed and experienced bidder.

E-bid documents will be available for download from **11.05.2026** by **12:00 Hrs.** Pre-bid meeting will be held on dated. **18.05.2026** at **11:00 AM** in office of the Superintending Engineer, Construction Circle, U. P Jal Nigam (Urban), Prayagraj. E-bids can be submitted till **01.06.2026** up to **17:00 Hrs.** and technical bid shall be opened on **02.06.2026** at **11:00 Hrs.** in office of the Superintending Engineer, Construction Circle, U. P Jal Nigam (Urban), Prayagraj in presence of contractor or their authorized representative, E-tender Cost is **Rs 20000.00+ GST @ 18%**. Details are available on U.P. Govt. e- procurement portal <http://etender.up.nic.in> & U.P.J.N (Urban) website [www.jn.upsdc.gov.in](http://www.jn.upsdc.gov.in).

  
(Sanjay Kumar Ranjan)  
Superintending Engineer

## **LIST OF IMPORTANT DATES**

Sl. No.	Description	Dates
<b>1</b>	<b>Name of Work</b>	Survey, Soil Investigation, Design, Supply of all materials, labour, T&P etc. Required for Construction/Repairing , Erection, Testing And Commissioning of Water Supply Works Such RCC Over Head Tank, Pump house, Staff quarter, Boundary wall, Gate, Site development, renovation of Existing facilities including laying & jointing of rising main/Distribution System, providing Functional Water supply house Connections , construction of tube wells including SCADA automation and other appurtenant works of “Re-Organization of Nagar Panchayat Mau Aima Water Supply Scheme District-Prayagraj under AMRUT 2.0 Programme” on Turnkey basis as specified in Tender Document. The scope of works also includes trial and run of 3 month and defect liability period of 12 months for civil works and 24 months for E&M works after completion of successful trial and run. All completed and commissioned works of above scheme shall be handed over to Nagar Panchayat Mau Aima ,District - Prayagraj after 3 months of successful trial run period.
<b>2</b>	<b>Completion Period for Construction</b>	<b>18 Months (including rainy season and 03 months Trial &amp; Run)</b>
<b>3</b>	<b>Period of Trial Run</b>	03 Months (After completion of construction period)
<b>4</b>	<b>Period of Defect Liability</b>	12 Months For Civil Works and 24 Months for E&M Works.
<b>5</b>	<b>Date of Issue of Notice Inviting Tender</b>	<b>08.05.2026</b>
<b>6</b>	<b>Period of Sale of Bidding Documents:</b>	From. 11.05.2026 12.00 Hrs To 01.06.2026 up to 17.00 Hrs Through E-Tendering Portal <a href="https://etender.up.nic.in">https://etender.up.nic.in</a>
<b>7</b>	<b>Website of UP Jal Nigam:</b>	<a href="http://www.jn.upsdc.gov.in">www.jn.upsdc.gov.in</a>
<b>8</b>	<b>Last date and time for submission of queries:</b>	18.05.2026 up to 17.00 Hrs
<b>9</b>	<b>Time, Date and Place of Pre-bid Meeting Date (If any):</b>	18.05.2026 <b>Time</b> -11:00 am <b>Place:</b> Office of the Superintending Engineer, UP JAL NIGAM(URBAN),Prayagraj
<b>10</b>	<b>Bid Submission Start Date:</b>	<b>11.05.2026</b>
<b>11</b>	<b>Last Date of Bid Submission:</b>	<b>01.06.2026 Time- upto17.00hrs</b> On E-Tendering Portal <a href="https://etender.up.nic.in">https://etender.up.nic.in</a>
<b>12</b>	<b>Date, Time and Place for opening Technical Bid/Bids Date</b>	<b>02.06.2026 Time</b> -11:00 Hrs <b>On E-Tendering Portal</b> <a href="https://etender.up.nic.in">https://etender.up.nic.in</a> <b>Place</b> -Office of the Superintending Engineer, Construction Circle, UP Jal Nigam (Urban) Prayagraj. Mob. 9473942672 <b>E-mail id</b> – <a href="mailto:eecdalld@rediffmail.com">eecdalld@rediffmail.com</a> <b><u>se.ccpvj@gmail.com</u></b>
<b>13</b>	<b>Time and Date of opening Financial Bids:-</b>	Date to be notified through Portal.
<b>14</b>	<b>Bid Validity Period:</b>	120 days (One hundred and twenty days)

**SECTION-2**  
**CHAPTER-1**  
**BRIEF PARTICULARS OF WORK**

**(The Particulars of the work described hereunder are provisional. They are liable to change and should be considered only as advance information to assist the bidder.)**

**A- Project Name , Area & Objective :** - “ Survey, Soil Investigation, Design, Supply of all materials, labour, T&P etc. Required for Construction/Repairing , Erection, Testing And Commissioning of Water Supply Works Such RCC Over Head Tank, Pump house, Staff quarter, Boundary wall, Gate, Site development, renovation of Existing facilities including laying & jointing of rising main/Distribution System, providing Functional Water supply house Connections , construction of tube wells including SCADA automation and other appurtenant works of “Re-Organization of Nagar Panchayat Mau Aima Water Supply Scheme District-Prayagraj under AMRUT 2.0 Programme” on Turnkey basis as specified in Tender Document. The scope of works also includes trial and run of 3 month and defect liability period of 12 months for civil works and 24 months for E&M works after completion of successful trial and run. All completed and commissioned works of above scheme shall be handed over to Nagar Panchayat Mau Aima ,District - Prayagraj after 3 months of successful trial run period.”

**WORKS UNDER THIS CONTRACT:** The various component i.e. Over Head Tank, Distribution system, Rising Mains, Staff quarters, Boundary walls & Site development, Permanent Reinstatement of roads, repairing of old OHT etc and E&M works and their cost have been tabulated as below.

SI No	Description of Works	Quantity	Unit
<b>(A)</b>	<b>Civil Works</b>		
1	Pump House cum chloronome	7	Nos.
2	R.C.C. Over Head tank 1100 KL/22 M	1	Nos.
3	R.C.C. Over Head tank 850 KL/22 M	1	Nos.
4	Rising Main 150 mm dia D.I. K-9	6.25	Km
5	Distribution System	34.09	Km
6	Staff Quarter	3	Nos.
7	Boundary Wall, Approach Road and Gate	1	Job
8	House Connection	4841	Nos.
9	Shifting of existing House Connection	1445	Nos.
10	Renovation of OHT 900 KL/16 M	1	Job
11	Dismantling of 300 KL OHT	1	Job
12	Renovation of Pump house	2	Job
13	MCS Room	1	01 No
14	Ground Water Recharge Work	2	Job
15	Pillar Gurder Work	1	Job
<b>(B)</b>	<b>E&amp;M Works</b>		
1	Construction of Tube well New 07 & Rebores 01 Nos	8	Nos.
2	Pumping plant, Dozer & V. Stabl. & Other E&M Work	9	Job
3	Work of SCADA LCS & ESR for Tube wells	9	Nos
4	ESR and MCS SCADA work	3	Job
5	Automatic Chlorinating plan for existing TW	3	Nos.
<b>(C)</b>	<b>Cost of Power Connection</b>		
1	Cost of Power Connection for all Tubewells including Shifting of Power Connection	01	Job

## CHAPTER-2

### INSTRUCTION TO BIDERS FOR PRE-QUALIFICATION

2.1. Throughout these documents-

- 2.1.1. The terms “bid” and “tender” and their derivatives (bidder/ tenderer, bid/ tender, bidding/ tendering, etc.) are synonymous.
- 2.1.2. The terms "Performance Security", "Performance Guarantee"& "Security Deposit" are synonymous and have been used interchangeably.

#### **2.2. Prohibition from Bidding:**

- 2.2.1. Bidders shall not be under a declaration of ineligibility for corrupt and fraudulent practices by the Central or State Government Department, U.P. Jal Nigam (Urban) or any public undertaking, autonomous body, authority by whatever name called under the Central or the State Government.
- 2.2.2. Any bidder having **criminal record** is not allowed to participate in the bidding process. Any person who is having criminal cases against him or involved in the **organised crime or gangster activities or Mafia or Goonda or Anti-social activity** are strictly prohibited to participate in the bidding process. If it is established that any bidder has **criminal record, his bid shall be automatically cancelled.**
- 2.2.3. Any bidder who is an Advocate and/or Registered with any State Bar Council/Bar Council of India shall not be allowed to participate in the bidding. If it is established that the contractor is registered with the state bar council, **his bid shall be treated as automatically cancelled.**
- 2.2.4. Any agency / firm or its known Partners/ Directors against which/ whom any investigating authority has instituted any vigilance enquiry or there are criminal proceedings in any Court of Law or has been **debarred or blacklisted** by any Govt. / Semi Govt. /Board/ Corporation shall not be considered for award, unless such debarment/blacklisting period has ended. An affidavit to this effect shall be submitted by the participating agencies / firms.
- 2.2.5. **The bidder shall have to enter into Integrity Pact with U.P. Jal Nigam (Urban), he should therefore acquaint himself with the contents of the Integrity Agreement.**

2.3. The bidder has to upload and produce for execution of agreement, original copies of Integrity Agreement, Annexures, Forms- I to IX. Original Experience certificates shall be returned after verification. Rest of the documents may be retained for execution of Agreement.

2.4. The Pre-qualification of the agencies / firms is confined to invitation of such firms who have earlier demonstrated their capability and capacity in executing similar projects in a time bound, prestigious & professional manner with high standards of workmanship within specified cost. The pre- qualification will be made on basis of the past record and successful completion of such projects in the stipulated time with good quality, proven technical competence, experience of handling works of comparable magnitude and complexity, expertise and know-how in the relevant field, financial resources, technical manpower and construction equipment owned by Bidders and other requirements laid down in the prescribed Pre-qualification document.

- 2.4.1. The tender will be on Turnkey basis including trial run and defect liability period as described, which will commence after the project is commissioned, trial run completed and handed over to the authority designated by Employer. *It may be distinctly understood that responsibility of handing over of the project shall lie with the selected bidder.*
- 2.4.2. The time allowed for carrying out the work will be reckoned from the date of start as **defined in Schedule „F“ or from the first date of handing over of the site, whichever is later, in accordance with the phasing, if any, indicated in the bid documents.**
- 2.5. The Bidder intending to submit pre-qualification documents will have to be experienced in executing similar type of works as defined in NIT and further as demonstrated in their experience certificate. **Such experience certificate should be detailed enough to make an informed decision. Ambiguous certificates shall not be considered for evaluation of bidder's eligibility.**
- 2.6. **Clarification of Bid Documents:-**
- 2.6.1. The bidder or his official representative is invited to attend a pre-bid meeting (**if scheduled**) which will take place at the address, venue, time and date as indicated in "List of Important Dates"
- 2.6.2. The purpose of the meeting will be to clarify issues and to answer questions on any matter that may be raised at that stage.
- 2.6.3. The bidder is requested to submit any questions in writing or by fax/e-mail to reach the Employer before last date of submission of queries as indicated in "List of Important Dates". Any query received after scheduled date and time would not be entertained and will be treated as void.
- 2.6.4. Minutes of the meeting, including the text of the questions raised (without identifying the source of enquiry) and the responses thereon will be posted exclusively on e-procurement portal.
- 2.6.5. Any modification of the bidding documents which may become necessary as a result of the pre-bid meeting shall be made by the Employer exclusively through the issue of an Addendum and will be posted exclusively on e-procurement portal.
- 2.6.6. Non-attendance at the pre-bid meeting will not be a cause for disqualification of a bidder.
- 2.7. Pre-qualification document contains various formats and the same are to be used for furnishing the required information. The enclosed formats should be filled in completely and response must be provided for each item included in Appendices. In the event that a Bidder considers it inappropriate to respond to a particular item; this shall be completed as **not applicable**. If necessary, additional pages may be attached. ***Bidder should note that all the formats prescribed, need to be filled even if such information is Nil. It should be clearly indicated, failing which the bid may be treated as non-responsive.***
- 2.8. All information requested shall be provided in English language, type written. Each page of the Pre-qualification document shall be duly signed and page numbered by the Bidder or his authorized representative, **over writing should be avoided**. Correction, if any, should be made by neatly crossing out, initialling, dating and re-writing.
- 2.9. Supporting documents shall be uploaded after scanning original or photocopy, as may be applicable, duly attested by a Gazetted Officer / Magistrate/ Notary as prescribed in NIT. Document generated by the firm can be self-attested. **The Bidder shall have to submit original documents as and when demanded.**
- 2.10. Each sheet shall be duly signed by the Bidder or a person or persons duly authorized to sign on behalf of Bidder in case of Partnership firm or Limited company. Such authorization shall be supported by written power of Attorney accompanying the application.
- 2.11. Failure to provide information which is essential to judge Bidder's qualifications or to

provide timely clarifications or substantiation of the information supplied may result in disqualification of the Bidder for the particular bid.

- 2.12. All documents submitted within due time and date, by the Bidders will be treated as confidential and will not be returned.
- 2.13. U.P. Jal Nigam (Urban) may not necessarily inform all Bidders of the result of their applications. It reserves the right to accept or reject any or all applications and to annul the pre-qualification process and there by reject all Bidders without incurring any liability to the affected Bidders or any obligation to inform the Bidder of the ground for the action.
- 2.14. The intending bidders who desire to see the site may visit at their own cost.
- 2.15. U.P. Jal Nigam (Urban) will not reimburse any costs involved in the preparation and submission of pre-qualification document or in connection with any site visit made.
- 2.16. Suppression of Facts:** Any information furnished by the Bidder found (immediately or at later stage) to be forged or incorrect or concealment of any information, would render him liable to be debarred from tendering / taking up of works. Further, action may be taken as per tender conditions **including forfeiture of earnest money deposited.**
- 2.17. Information regarding litigation in past five years which the bidder is involved in, has to be submitted in prescribed format. The name of the parties' concerned, and disputed amount, should also be given in the enclosed format.
- 2.18. Bank Solvency Certificate in prescribed format-'II-B' (equivalent to at least 40 percent of the cost put to bid)** issued by a Scheduled Commercial Bank should be uploaded with the bid. **It should also be kept validated during the contract period.**
- 2.19. NATURE OF FIRM/BIDDER:**

2.19.1. The Bidder may be individual, propriety firm, firm in partnership, Joint Ventures (if permitted), limited company- public or private or corporation. In case of individual/proprietorship firm the bid is required to be signed by sole proprietor with his full name and current address, **while in case of partnership firm the bid should be signed by all those partners in the firm with full name and current address, an affidavit to this effect and certified copy of partnership deed (as registered with registering authorities) is required to be attached with bid.** However, in case of limited firms / companies, the bid is required to be signed by the authorized signatory, a power of attorney drawn in whose favour along with a copy of Memorandum & Articles of Association **(as registered with registering authorities)** duly notarized by a Public Notary should be attached with the bid.

**2.19.2. Joint Venture (JV): The number of JV partners shall be limited to 2 (Two) in number.**  
The bidder shall further follow guidelines for Joint Venture Firms as described in **Clause of Chapter-3.**

**2.19.2.1. ELIGIBILITY FOR JV/CONSORTIUM:**

- The Joint Venture is allowed with maximum two member out of which lead member has to be an Indian firm/company. Foreign companies can be part of Joint Venture.
- The lead Member of the JV/Consortium must have minimum 51% of the Stake Holding. Member of Joint venture, other than the lead member, should have at least 30% Stake Holding.
- Lead member should have a turnover of at least 51% of the total turnover required.
- Lead member should have a Solvency of at least 51% of the total Solvency required.
- Project costing <10 Cr-JV/Consortium shall have the required technical experience collectively.
- Project costing >10 Cr. Up to 25 Cr. Lead member of JV/Consortium should have at least 30% technical experience or required technical experience.
- Project Costing >25 Cr. Both members of JV/Consortium should have at least 30% technical experience

or required technical experience.

- A member of JV/Consortium shall not participate either in individual capacity or as a member of another JV/Consortium in the same tender.
- Tender form shall only be submitted in the name of the JV/Consortium. Tender fees may be submitted by lead partner/JV.
- A single Performance Guarantee shall be submitted by the JV/Consortium in the name of the JV/Consortium.
- **Tender for more than 05 Projects of AMRUT 2.0 will not be allotted to any firm as JV Partner at any time. If a firm is allotted 05 Tenders as JV Partner, then that firm will not be able to participate in any tender as JV until one of the works of the allotted 05 Tenders is finished and completion certificate have been issued by the concerned office. The above condition will not apply for individual participation in the tender.**
- All the member of the JV/Consortium of Bidders shall be liable jointly and severally for the execution of the project.  
For further details and methodology Clauses 2.20.2 and 3.6 of Instructions to the Bidder(ITB) must be referred.

**Note for 2.20.2.1: -**

- a) Value of a completed work done by a Member in an earlier JV Firm/ Partnership firm shall be reckoned only to the extent of the concerned member's share in that JV Firm/Partnership firm for the purpose of satisfying his/her compliance to the above- mentioned technical eligibility criteria in the tender under consideration.
- b) Turnover on construction works by a Member in an earlier JV Firm/Partnership firm shall be reckoned only to the extent of the concerned member's share in that JV Firm/Partnership firm for the purpose of satisfying compliance of the financial eligibility criteria in tender under consideration.

**2.19.2.2. JV/CONSORTIUM REQUIREMENTS:**

Bids submitted by JV/Consortium of Bidders must comply with following requirements:

- a) The JV/Consortium shall furnish a joint bidding agreement (the joint bidding agreement) on a non-judicial Stamp of a minimum of Rs. 100 (rupees one hundred only) as per the format provided in the relevant Bid Form, which shall be legally binding on all the Members. In case the JV/Consortium is selected, the Joint Bidding Agreement shall continue in full force and effect till the contract agreement signed with the JV/Consortium becomes effective and thereafter relevant equity lock in provisions will be part of Contract Agreement. However, in the case the JV/Consortium is not selected for award of the project, the joint bidding agreement will stand terminated upon return of the Bid Security by U.P. Jal Nigam (Urban).
- b) A member meeting the requirements described in **para 2.20.2 shall** be authorized and nominated as the lead member to act and represent all the members of the JV/Consortium for bidding and implementation of the projects. This Authorization shall be evidenced by submitting a power of Attorney signed by legally authorized signatories of all the members as per format provided in the Bid Documents.
- c) Change of the lead Member will not be allowed under any circumstances.

- 2.20. Not with standing anything mentioned elsewhere in the bid document, **subcontracting shall not be permitted** except for the works like SCADA/ Automation/I.T. solutions and construction of electric sub-station which can be out sourced/sub-contracted to other firms after approval of Engineer-in charge, but the main contractor will be responsible for the quality of work and its timely completion. For such out sourcing the successful bidder shall obtain prior permission from the Engineer-in-charge, who will accord

- his approval based upon past experience on similar works performed by the outsourced agency.
- 2.21. The Bidder shall adopt the Percentage Rate Method and quote the same in e-tender portal as specified in the excel sheet for the purpose; only the same option is allowed to all the Bidders. Percentage Rate Method requires the bidder to quote a percentage above / below/ at par of the cost of BOQ.
- a. In case the lowest tendered amount (cost of work put to bid compared with amount worked on the basis of percentage above/below) of two or more contractors is same, such lowest contractors will be asked to submit sealed revised offer in the form of letter mentioning percentage above/below on cost of work put to bid including all sub sections/sub heads as the case may be, but the revised percentage quoted above/below on cost of work put to bid or on each sub section/sub head should not be higher than the percentage quoted at the time of submission of tender. The lowest tender shall be decided on the basis of revised offers. In case any of such contractors refuses to submit revised offer, then it shall be treated as withdrawal of his tender before acceptance and 50% of earnest money shall be forfeited.
- If the revised tendered amount of two more contractors received in revised offer is again found to be equal, the lowest tender, among such contractors, shall be decided by draw of lots in the presence of General Manager/Superintending Engineer concerned.
- In case all the lowest contractors those who have quoted same tendered amount, refuse to submit revised offers, then tenders will be recalled after forfeiting 50% of EMD of each contractor.
- Contractor(s), whose earnest money is forfeited because of non-submission of revised offer, shall not be allowed to participate in the re-tendering process of the work.
- 2.22. The Bidder will furnish the following mandatory information, scanned documents/certificates of originals on e-tender portal, failing which the bidder may get disqualified. Additional pages can be added to give complete desired information. **Nil information is also required to be indicated as such and submitted. Omission of any format/information shall be taken as 'Nil' information and will be evaluated accordingly.**
- a. Proof of submission of Tender Fee and Earnest Money Deposit (EMD). In case EMD is deposited in the shape of Bank Guarantee it should be substantially in the format as per **Annexure-6**. (Original).
  - b. Integrity Pact- As per **Annexure-2** (Original)
  - c. General information in **Form-I** (Original)
  - d. Declaration on **Form - I A**. (Earnest Money) (Original)
  - e. Declaration on **Form - I B**. (Affidavit of Bid Validity)(Original)
  - f. Standard Affidavit on **Form- I-C**. (It may be translated into English by bidders outside of U.P. however substance of the contents should not be altered) (Original)
  - g. Financial information in **Form- II (A)**.(Original)
  - h. Bank Solvency Certificate issued by a prescribed Bank on **Form II-B**.(Original) or Haisiyat Certificate issued by District Magistrate.
  - i. *List of similar works executed during last 10 years as per **Form-III&IIIA**. (See **Clause 3.1** of this section) (Original)*
  - j. *Details of work which are in progress/awarded/bid have been submitted as on **the date of** bid submission. **Form-IV** (Original)*
  - k. Details of technical and administrative personnel with bidder in **Form-V**.(Original)
  - l. Format for performance report in **Form-VI**.(Original)
  - m. Details of construction plants and equipments with the bidder in **Form-VII**.(Original)
  - n. Litigation history on **Form- VIII**.(Original)
  - o. Letter comprising Bid - **Form-IX**(Original)
  - p. Proof of Registration with GST EPF, ESI etc.(As issued by authority)
  - q. All other documents required for Partnership/Limited/JV firms as described in relevant paras.(**Annexures-3 to 5**)
  - r. Any other document required in terms of the Bid document.
- The bidder shall complete the check list as per **Annexure-1** and submit along with other documents.

- 2.23. The tender shall be submitted in two bid system in accordance with the procedures detailed.
- 2.24. It is mandatory that each application shall contain the following:-
- a. **Technical Bid-** Proof of tender fee, EMD, Integrity Pact/Agreement, Information called for in the “Forms I to IX etc.” and Declaration I-A, I-B, I-C and audited balance sheets of Bidder / Contractor for immediate last five consecutive financial years, duly certified by Statutory Auditor as prescribed in NIT bid Document, Auditor's report (in case of companies and corporations) and all other Annexures etc. must be digitally signed and uploaded on e-procurement portal.
  - b. **Financial Bid-** Must be quoted in excel sheet (or as prescribed) for financial bid on e- tender portal.
- 2.25. *The bidder must submit acknowledgement of Income Tax return submitted online along with relevant 26AS for the last 3 years. The demand status as displayed on Income Tax portal is to be enclosed for verification of Tax demand.*
- 2.26. Bidders are particularly advised to fill and upload the details strictly as per the enclosed forms. Tenders are liable to rejection if relevant details are not furnished in prescribed formats and also which do not meet the qualification requirement given in the paragraphs that follow. The Bidder may furnish any additional information, along with his application which in his opinion will highlight his capacity to perform.
- 2.27. *Firm should have valid registration in GST (as applicable) and they have to submit **attested copies of the registration certificates**. Contractor will have to register in labour cess deptt. within a week of award of the works.*
- 2.28. ***The contractor whose bid is accepted will also be required to furnish either copy of applicable licenses/ registrations or proof of applying for obtaining labour licenses, registration with EPFO, ESIC and BOCW Welfare Board including provident fund code no. if applicable and also ensure the compliance of aforesaid provisions by the sub-contractors, if any engaged by the contractor for the said work and Programme Chart (Time and Progress) within the period specified in Schedule F.***
- 2.29. Original copy / attested copy of the partnership deed, if it is a partnership firm and notary attested copy of registration certificate / MOA (as registered with registered with registering authorities), in case of Company and authorized declaration in case of Sole Proprietorship Firm should be submitted with PQ document.
- 2.30. General Power of Attorney / Special Power of Attorney substantially in format annexed, revalidated & notarized be submitted by firm / bidder in favour of the authorised person/ partner who has signed the tender/will sign the agreement as the case may be, the tender documents with telephone No. and complete postal address. **Affidavit as prescribed should be annexed on non-judicial stamp paper of Rs.100 duly signed by notary.**
- 2.31. The Bidder shall extend his services free of charge, to the representative of the U.P. Jal Nigam(Urban) to visit the project/works from any of his referred project works, if the UPJN desires so. While applications are under consideration, Bidders and their representatives, or other interested parties, are advised to refrain from contacting by any means, any personnel or representative on matters related to the applications under consideration.
- 2.32. The Employer or his authorized representative if necessary, will/may obtain clarification of applications by requesting such information from any or all Bidders in writing. Bidders will not be permitted to change the substance of their applications after submission of tender. Non- compliance with this provision will be a cause of disqualification.
- 2.33. U.P. Jal Nigam (Urban) reserves to itself the power to relax non-essential requirements of the bid which do not have impact on eligibility of the bidder.
- 2.34. The credentials submitted in respect of pre-qualification of the bidder, more particularly that of the lowest evaluated bidder shall be verified before award of work. Any information furnished by the bidder found to be incorrect either immediately or at a later date, suppression of information in forms, statements, enclosure and declarations **would render him liable to be blacklisted/disqualified and debarred from tendering of work for UPJN for a period of one year besides forfeiture of his bid security/ security.** If such bidder happens to be enlisted contractor of any class in UPJN, his name shall also be removed from, the approved list of contractors.
- 2.35. On acceptance of the tender, the name of the accredited representative(s) of the contractor who would be responsible for taking instructions from the Engineer shall be communicated in writing to the Engineer.

### **2.36. Performance Guarantee/Security Deposit/Additional Performance Guarantee:**

2.36.1. Performance Guarantee 10 % of the contract cost will have to be submitted at the time of signing the contract in the form of FDR/Bank Guarantee (specified in **Schedule-F**) from any scheduled commercial bank accepted at the time of signing of contract and rest 5% may be deducted from the initial running bill in a single deduction or at the rate of minimum 10 % of the gross bill amount of running bill. However, in any case whole amount of balance performance guarantee shall be deducted within one year.

Works for which the cost of the tender received is more than 10% below the estimated cost of works, in such situation, the performance security for first 10% below shall be 10% thereafter, additional performance security @ 0.50 % for each 1% further below than 10 % shall be deposited by the firm in order to safeguard against contractor leaving the works.

2.36.2. The Bank Guarantee shall be in a prescribed form (**Annexure-7**). Such bank guarantee should be verifiable & encashable from the branch situated in the city where Divisional Office is situated.

2.36.3. The earnest money deposited along with bid shall be returned after receiving the aforesaid performance guarantee. In case the contractor fails to deposit the said performance guarantee within the **period as indicated in Schedule „F“** including the extended period if any, the Earnest Money deposited by the contractor shall be forfeited automatically without any notice to the contractor.

In order to safeguard against contractors leaving the works after quoting very low rates below the S.O.R. additional performance security have to be deposited by the contractors. **Additional performance security** to be deposited by the firm shall be at following rates: -

- a) Upto 10% below the estimated cost of works- Nil
- b) Above 10% estimated cost of works - @ 0.50% for each 1.00% quoted below.

2.37. Contractor shall not divert any advance payments or part thereof for any other purpose other than needed for completion of the contracted work. All advance payments received as per terms of the contract (i.e. mobilization advance, secured advance against materials brought at site and / or for work done during interim stages, etc.) are required to be re-invested in the contracted work to ensure advance availability of resources in terms of materials, labour, plant & machinery needed for required pace of progress for timely completion of work.

2.38. The contractor shall obtain all mandatory approval and No Objection Certificate/ Consent for Establishment from local body authorities like local Fire department, local ground water authority, water way authorities, local electricity supply authority, local pollution control board, Forest, U.P. Jal Nigam, Environmental clearance, Lift inspectorate, Central Electricity Authority, Airport Authority of India (AAI) etc. However U.P. Jal Nigam will assist the contractor to obtain clearances by way of correspondence.

2.39. The statutory payments or fees made to local/statutory bodies shall be reimbursed by on production of proof of such payments.

## CHAPTER –3

### **ELIGIBILITY CRITERIA AND INFORMATION REQUIRED TO BE FURNISHED BY THE BIDDERS**

The qualification information is required to be furnished in the enclosed forms. The Bidders should have following minimum qualifying requirements.

**3.1 ELIGIBILITY REQUIREMENTS:** Minimum requirements for pre-qualification are as follows:

- a) **Turnover:** The average audited annual turnover on construction works of the bidder during the immediate last three consecutive financial years should be at least **30% of the cost of work put to tender** i.e. **Rs. 617.29 lacs**. Year in which no turnover is shown will also be considered for working out the average.

In case of JV the Turnover shall be subject to **Clause 2.20.2** of Instructions to Bidder.

- b) **Solvency Certificate:** Solvency Certificate of minimum 40% of the tender value i.e. **823.05** will be required to be submitted. The bidder must maintain his solvency till completion of project.

- Solvency Certificate issued by any Scheduled Commercial Bank shall be accepted, which will be valid for a period of one year from the date of issue unless otherwise mentioned.

OR

- Solvency Certificate issued by District Magistrate will also be accepted, which will have a validity of one year from date of issue unless otherwise mentioned.

In case of JV the Solvency shall be subject to Clause 2.20.2 of Instructions to Bidder.

- c) **Net Worth:** The bidder must have a positive net worth in the immediate last financial year. and same should be certified by Statutory Auditor. Further, net worth of all the partners in a JV should individually be positive. At the time of Submission of bid, contractor has to upload certificate from statutory auditor of the firm mentioning year wise audited financial turnover on Construction Works of last 05 years. Further details, if required may be asked from the contractor after opening of technical

- d) **Income Tax:** The bidder must submit acknowledgement of Income Tax return submitted online along with relevant 26AS for the last 3 years. The demand status as displayed on Income Tax portal is to be enclosed for verification of Tax demand.

- e) **Available Bid Capacity:** The available bid Capacity of the bidder at the time of bidding shall be more than the total estimated cost of the work for which the tender is invited.

The available Bid Capacity shall be assessed using following formula:-

**Assessed Available Bid Capacity**

$$= 2 \times A \times N - B \quad \text{Where}$$

A= Maximum turnover during the last five financial year (corrected to the current level of value)

N= Stipulated period of execution of the work for which the tender is invited in years. B= value of existing commitments to be completed during the execution period of bid.

The turnover shall be corrected to the current level of value by multiplying with the updation factor given elsewhere with NIT/Bid document.

**Note:- 1) The minimum bid capacity of each JV member must be in the ratio of their stake holding in JV and sum of bid capacity of JV must be more or equal to required bid capacity.**

**f) Experience of Similar Works:** The Bidders who inter-alia fulfill the following requirements shall be eligible to apply. Firm should have successfully completed, Tested and commissioned similar works (**Similar work shall mean “Completed, Tested and Commissioned Works of Piped Water Supply scheme and its associated infrastructure works. )** mentioned below during last Ten years as on date of publication of NIT, satisfying followings.

(i) Three Completed ,Tested and Commissioned works each costing not less than the amount equal to 30% or more of the estimated cost put to tender (i.e. Rs. **617.29 lacs**).

OR

(ii) Two Completed , Tested and Commissioned works each costing not less than the amount equal to 40% or more of the estimated cost put to tender (i.e. Rs. **823.05 lacs**).

OR

(iii) One Completed and commissioned work each costing not less than the amount equal to 60% or more of the estimated cost put to tender (i.e. Rs **1234.58 lacs**).

**Particular Condition :- The experience must include one work of 2/3rd size (i.e. 350 mm x 2/3 = 250 mm Dia) of maximum diameter mentioned in BOQ of this NIT for a minimum length of 500 meters.**

**Note:-**

The Bidder should have experience of work Contract including testing and commissioning successfully in last 10 years as on date of publication of NIT.

(i) In Case of Turn Key projects experience of works/components put to tender namely OHT , Tubewell , Distribution Networks for water supply project will also be considered accordingly.

(ii) The Experience in Foreign countries of a subsidiary or parent company will also be considered for qualification. In Case the company is not registered in India the experience has to be certified by the respective Embassy office/Apostille (in case of members of Hague Apostille Convention )

(iii) The works Like SCADA/Automation /I.T. Solutions and Construction of Electric Sub-Station can be sourced /sub-contracted to other firms after approval of Engineer – in – Charge , but the main Contractor will be responsible for the quality of work and its timely Completion.

(iv) Sub-contracting / subletting experience shall be considered valid only if the Experience certificate is directly issued to the sub-contractor by the department and work Experience provides all relevant information and supported by relevant documents like 26 AS, a proof of payment received from the client.

The value of experience on construction works and turnover shall be brought to current costing level by enhancing the actual values of work at simple rate @ 7% per annum calculated from the date of completion to the date of publication of. A typical illustration is as below.

Financial Year	Escalation/ Enhance factor
First Year	1.00
Second Year	1.07
Third Year	1.14
Fourth Year	1.21
Fifth Year	1.28

(v) The quantities given in the Bill of Quantities are estimated and provisional, and are given to provide a common basis for

bidding. These are liable to change up to any extent for which no claim except as provided under contract shall be admitted.

- (vi) The bid document consisting of Technical (eligibility) bid & financial bids including specifications, the bills of quantities of various types of items to be executed and the set of terms and conditions of the contract to be complied with and other necessary document are available on "<https://e-tender.up.nic.in>".
- (vii) The technical bid shall be opened first on due date and time as mentioned above. The time and date of opening of financial bid of contractors, qualifying the technical bid shall be communicated to them on a later date through e-tender portal/ website.
- (viii) If the Bidder feels that technical credentials of his own or other Bidders have been wrongly evaluated/verified, he may raise **objections within 2 (two) working days** from the date of uploading of result. No requests/objections shall be entertained beyond above limit, else it may be treated as an obstruction in tender process and shall be dealt with accordingly.
- (ix) U.P. Jal Nigam (Urban) reserves the right to reject any prospective application or to cancel entire bid process without assigning any reason whatsoever.
- (x) E-tender document fee is non-refundable. It shall be deposited in the account of **Executive Engineer, Construction Division (I), UP Jal Nigam(Urban), Prayagraj** only by RTGS/NEFT in **Union Bank of India, Chowk, Prayagraj, A/c No.- 394302010994456, IFSC Code- UBIN0807095**.

### **Earnest Money:**

- (a) EMD will be 2 % for works up to Rs 5.00 Cr. and 1 % or Rs 10.00 lacs whichever is higher for works above Rs 5.00 Cr.
- (b) EMD should be paid through RTGS or in the form of FDR/ Bank Guarantee issued by any scheduled commercial Bank.
- (c) This Bank Guarantee must be in the prescribed format given in Annexure-6 of tender document and it should be valid for 65 days beyond the validity period of Tender.
- (d) In case of JV Earnest money may be submitted by lead partner/JV.
- (e) The RTGS component of earnest money shall be deposited in the account of **Executive Engineer, Construction Division (I), UP Jal Nigam (Urban), Prayagraj** only by RTGS/NEFT in **Union Bank of India, Chowk, Prayagraj, A/c No.- 394302010994456, IFSC Code- UBIN0807095**.
- (f) The bidder shall deposit tender fees and earnest money **separately** in account mentioned as above. Further he shall upload digitally signed copies of original receipts of bank showing clearly the above details and/or the Bank Guarantee.
- (g) In case EMD is submitted in the form of Bank Guarantee/FDR, bidder should ensure that such **Original Bank Guarantee/FDR is mandatorily deposited in the office of Executive Engineer, Construction Division(I), Uttar Pradesh Jal Nigam(Urban), Prayagraj on or before the day of scheduled date (during office hours) of opening of Technical Bid**, either in person or by Speed Post. The liability for timely submission shall lie with the Bidder, U.P. Jal Nigam(Urban) shall not be responsible for delay on account of any reason whatsoever.
- (h) It is made clear that Tender Fee and Earnest Money deposited in any other form besides as mentioned above sub-paras shall render the bid non-responsive.
- (i) In case of JV the EMD should be in the name/ from the account of JV or lead partner as specified in the JV agreement.
- (j) EMD if submitted in the form of BG/FDR should be pledged only in the favour of **Executive Engineer, Construction Division (I), Uttar Pradesh Jal Nigam (Urban), Prayagraj**.

All the Bank Guarantees/FDR submitted towards EMD/Performance Security/Additional Performance Security should be verifiable and encashable from a branch situated in a city where the office of Divisional Officer is located.

All the documents as specified in the technical bid/eligibility bid document should be uploaded within the period of bid submission. U.P. Jal Nigam (Urban) will not be liable for incomplete/inaccurate/non-submission of bid for any reason whatsoever including technical reasons. It is made clear that separate submission of originals of any documents (except Bank Guarantee/FDR) other than scanning and uploading them, are not required, unless called for,

after opening of financial bid.

2.39.1 The certificates should be certified by an officer not below the rank of Executive Engineer/ Project Manager or equivalent of any Central or State Government Department, U.P. Jal Nigam or any public Undertaking, autonomous body, authority by whatever name called under the Central or the State Government.

### **Performance Guarantee/Security Deposit/Additional Performance Guarantee:**

Performance guarantee @ 10% of the Contract cost will have to be submitted at the time of signing the contract in the form of FDR/ Bank Guarantee from any scheduled commercial Bank. Alternatively on request of the Contractor /firm, 5% of the performance Guarantee will be accepted at the time of signing of contract and rest 5% may be deducted from the initial running bill in a single deduction or at the rate of minimum 10% of the gross bill amount of running bill. However, in any case whole amount of balance performance guarantee shall be deducted within one year.

Works for which the cost of the tender received is more than 10 % below the estimated cost of works, in such situation, the performance security for first 10% below shall be 10% thereafter, additional performance security @ 0.50 % for each 1% further below than 10 % shall be deposited by the firm in order to safeguard against contractor leaving the works.

### **3.2 CREDENTIAL OF ASSOCIATES:**

- (i) The Bidder/Member may rely on the experience of its Associate(s) for demonstrating the Technical Capacity. For purposes of this Bid Associate means, in relation to the Bidder/ JV Partner, a person who controls or is controlled by, or is under the common control with such Bidder/ JV Partner (herein referred to as the “Associate”). As used in this definition, the expression “control” means, with respect to a person which is a company or corporation, the ownership, directly or indirectly, of more than 50% (fifty per cent) of the voting shares of such person, and with respect to a person which is not a company or corporation, the power to direct the management and policies of such person, whether by operation of law or by contract or otherwise.
- (ii) In such cases, the Bidder or relevant JV Partner shall have to **provide a certificate (along with the relationship tree) stating the exact relationship with such Associate** and control, in line with the definition of "Associate" as given above. The certificate should be as on date which is within 15 (fifteen) days prior to the Bid Due Date. Such certificate shall be certified by the Statutory Auditor of the Bidder / relevant Partner Firm of the JV.
- (iii) The Bidder or the JV Partner shall also submit a legally binding Undertaking from such Associate that the expertise of the Associate will be made available during the construction of the Project.

**3.3 PERSONNEL CAPABILITIES:** The Bidders must have qualified employed personnel to fill the following positions. The Bidders shall supply information on a prime candidate and an alternate for each position; both of whom shall meet the minimum experience requirements specified below:

Sl. No.	Position	Recommended Number	Total Experience (Years)	Experience in Similar Position (Years)	Minimum Qualification
Site Posting in accordance with mutually agreed work plan					
1	Graduate Engineer	1	5	1	B.E. /B. tech (Civil)
2	Diploma Engineer	3	5	1	Diploma (Civil)
3	Graduate Engineer	1	5	1	B.E(Electrical/Mechanical)
4	Diploma Engineer	2	5	1	Diploma (Electrical/Mechanical)
5	Supervisor	5	7	2	12 <sup>th</sup> /ITI
6	Plumber/Fitter/Welder	6	7	2	ITI
7	Foreman	4	5	2	12 <sup>th</sup> /ITI

The requisite information shall be furnished in **Form – V**

**3.4 EQUIPMENT CAPABILITIES:** The Bidders should own or have assured access (through Hire, Lease, Purchase Agreement, availability of manufacturing equipment's or other means) to the equipment/machines listed here under and in full working order and must demonstrate that based on known commitments, they will be available for use in the proposed Contract. The Bidders may also list additional equipment's that they would propose for the Contract together with an explanation of the Proposal. **Form-VII**

Sl. No.	EQUIPMENTS	MINIMUM REQUIREMENT
1	JCB-210	1
2	Concrete mixer	2
3	Vibrator	5
4	Tractor with hydraulic trolley	3
5	Water tanker	3
6	Generator 15 KVA	2
7	RCC form work centering plates	500 sqm
8	Levelling Instruments	2
9	Roller	2
10	H.D.P.E. hydraulic Pipe jointing/ welding Machine	1
11	Slum cone	3
12	Cube mold	8
13	Sieve (Coarse/fine sand)	2 set
14	Sieve (Aggregate)	2 set
15	Cube Testing Machine	1
16	Sectional/Hydraulic testing Machine	1

**3.5 LITIGATION HISTORY:** The Bidders shall provide accurate information on any litigation or arbitration resulting from Contracts completed or under its execution over the last 5 years in **Form VIII**.

In case of JV, Litigation History of all the JV Partner Firms shall have to be submitted

**3.6 Participation of Joint Venture (JV) Firms:**

**Eligibility For JV/Consortium-** Eligibility for a JV/Consortium shall be as per **Clause 2.20.2** . The JV/Consortium shall fulfill following requirements.

- The Joint Venture is allowed with maximum two member out of which lead member has to be an Indian firm/company. Foreign companies can be part of Joint Venture.
- The lead Member of the JV/Consortium must have minimum 51% of the Stake Holding. Member of Joint venture, other than the lead member, should have at least 30% Stake Holding.
- Lead member should have a turnover of at least 51% of the total turnover required.
- Lead member should have a Solvency of at least 51% of the total Solvency required.
- Project costing <10 Cr-JV/Consortium shall have the required technical experience collectively.
- Project costing >10 Cr. Up to 25 Cr. Lead member of JV/Consortium should have at least 30% technical experience or required technical experience.
- Project Costing >25 Cr. Both members of JV/Consortium should have at least 30% technical experience or required technical experience.
- A member of JV/Consortium shall not participate either in individual capacity or as a member of another JV/Consortium in the same tender.
- Tender form shall only be submitted in the name of the JV/Consortium. Tender fees may be submitted by lead partner/JV.
- A single Performance Guarantee shall be submitted by the JV/Consortium in the name of the JV/Consortium.

- Tender for more than 05 Projects of AMRUT 2.0 will not be allotted to any firm as JV Partner at any time. If a firm is allotted 05 Tenders as JV Partner, then that firm will not be able to participate in any tender as JV until one of the works of the allotted 05 Tenders is finished and completion certificate have been issued by the concerned office. The above condition will not apply for individual participation in the tender.
  - All the member of the JV/Consortium of Bidders shall be liable jointly and severally for the execution of the project.  
For further details and methodology Clauses 2.20.2 and 3.6 of Instructions to the Bidder(ITB) must be referred.
- (A) *A copy of irrevocable Joint Bidding Agreement (JBA) executed by the JV members shall be submitted by the JV firm along with the tender.* The complete details of the members of the JV firm, their share and responsibility in the JV firm etc. particularly with reference to financial, technical, and other obligations shall be furnished in the JBA. (The JBA format is at **Annexure-3**).
- (B) After the contract is awarded, the constitution of JV firm shall not be allowed to be altered during the currency of contract except when modification become inevitable due to succession laws etc. and in any case the minimum eligibility criteria should not get vitiated. However, the Lead Member should continue to be the Lead member of the JV firm. Failure to observe this stipulation shall be deemed to be breach of contract with all consequential penal action as per contract conditions.
- (C) **On award of contract to a JV firm, a single performance Guarantee shall be submitted by the JV firm as per tender conditions.** All the Guarantees like Performance Guarantee, Bank Guarantee for Mobilization Advance etc. shall be accepted only in the name of the JV firm and no splitting of guarantees amongst the members of the JV firm shall be permitted.
- (D) The joint bidding agreement shall have, inter-alia, following clauses:
- a) **Joint and several liabilities** – Members of the JV firm to which the contract is awarded, shall be jointly and severally liable to the Employer for execution of the project in accordance with General and Special conditions of the contract. The JV members shall also be liable jointly and severally for the loss, damages caused to the Employer during the course of execution of the contract or due to non-execution of the contract or part thereof.
  - b) **Duration of the Joint Bidding Agreement** – It shall be valid during the entire currency of the contract including the period of extension, if any and the defect liability period after the work is completed and handed over.
  - c) **Governing Laws** – The Joint Bidding Agreement shall in all respect be governed by and interpreted in accordance with Indian Laws.
  - d) **Lead Member** –The authorization for lead member shall be evidenced by submitting a power of Attorney signed by legally authorized signatories of all the members as per format provided in the Bid Documents. Change of the lead Member will not be allowed under any circumstances. Role of lead member shall be on behalf of the Joint Venture firm to deal with the tender, sign the agreement or enter into contract in respect of the said tender, to receive payment, to witness joint measurement of work done, to sign measurement books and similar such action in respect of the said tender/contract. All notices/correspondences with respect to the contract would be sent only to this lead member of the JV firm.
  - e) No member of the Joint Venture firm shall have the right to assign or transfer the interest, right or liability in the contract without the written consent of the other members and that of the Employer in respect of the said tender/contract.
  - f) **Memorandum & Articles of Association:** The Members undertake that if Memorandum of Agreement (MoA) & Articles of Association (AoA) of Firm is in consistence with

provisions of JV Agreement, then the MoA & AoA shall be amended accordingly.

**(P) Documents to be enclosed by the JV firm along with the tender:**

- a)** The JV shall nominate a Representative through Power of Attorney as per **Annexure-5** who shall have the authority to conduct all business for and on behalf of and all the Parties of the JV during the bidding process and, in the event of JV being awarded the contract, during contract execution.
- b)** Submit Power of Attorney by individual partners to lead partner as per **Annexure -4**.
- c)** In case one or more of the members of the JV firm is/are partnership firm(s), following documents shall be submitted:
  - i. Notary certified copy of the Partnership Deed,
  - ii. Consent of all the partners to enter into the Joint Bidding Agreement on a stamp paper of appropriate value (in original).
  - iii. Power of Attorney (duly registered as per prevailing law) in favour of one of the partners of the partnership firm to sign the JV Agreement on behalf of the partnership firm and create liability against the firm.
- d)** In case one or more members is/are Proprietary Firm or HUF, the following documents shall be enclosed:
  - i. Affidavit on Stamp Paper of appropriate value declaring that his/her Concern is a Proprietary Concern and he/she is sole proprietor of the Concern OR he/she is in position of "KARTA" of Hindu Undivided Family (HUF) and he/she has the authority, power and consent given by other partners to act on behalf of HUF.
- e)** In case one or more members is/are limited companies, the following documents shall be submitted:
  - i. Notary certified copy of resolutions of the Directors of the Company (Board of Directors) permitting the company to enter into a JV agreement, authorizing MD or one of the Directors or Managers of the Company to sign JV Agreement, such other documents required to be signed on behalf of the Company and enter into liability against the company and/or do any other act on behalf of the company.
  - ii. Notary certified copy of Memorandum and Articles of Association of the Company.
  - iii. Power of Attorney (duly registered as per prevailing law) by the Company authorizing the person to do/act mentioned in the Para e (i) above. **Annexure-5**.
- f)** All the members of the JV shall individually certify that they or their know partners/directors are not black listed or debarred by UP JAL NIGAM or any other Ministry/U.P. Jal Nigam of the Govt. of India/State Govt./Govt. Undertakings etc. from participation in tenders/contract on the date of opening of bids either in their individual capacity as members of the JV or the JV firm in which they were/are members.

**3.7 CONFLICT OF INTEREST:**

The Bidder shall not be one of the following:

- 3.7.1** Bidder (or any constituent thereof) and any other Bidder (or any constituent thereof) have common controlling shareholders/ partners/ directors.
- 3.7.2** A Firm or an Organization which has been engaged by the Employer to provide consulting services for preparation related to procurement for or implementation of this Project;
- 3.7.3** No Engineer of Gazetted rank or other gazetted officer employed in Engineering or Administrative duties in an Engineering department. of the State/ Central government is allowed to work as a contractor for a period of **two years** after his retirement from govt. services without government permission. This contract is liable to be cancelled if either the contractor or any of his employees is found any time to be such a person who had not obtained the permission of the government as aforesaid before submission of the tender or engagement in the contractor's service.
- 3.7.4** A contractor black listed/debarred by any Govt. body shall not be eligible to bid.

**3.7.5** Any partner of a JV firm shall not participate in tender for the same work in his individual capacity or a partner of any other JV.

### **3.8 UPDATING PREQUALIFICATION INFORMATION:**

The Bidders shall be required to update the financial information/capability used for pre-qualification at the time of submitting their Bids and to ensure their continued compliance with the qualification criteria. A Bid shall be rejected if the Bidder's pre-qualification thresholds are no longer met at the time of issuing letter of acceptance (LOA).

### **3.9**

#### **3.9.1 GENERAL**

- i. Only Bidders who have been pre-qualified under this procedure will have their Financial Bids opened.
- ii. A Firm can submit only one Bid for the Contract. If a Firm submits more than one Bid, all bids which include that firm will be rejected.

#### **3.9.2 BID SECURITY/EARNEST MONEY/BID VALIDITY:**

- i. The Bid Security/EMD shall be deposited only by mechanism of as outlined in NIT. **Tender Fee and EMD must be submitted by the bidder out of his own resources else his bid shall be disqualified.**
- ii. Any bid not uploaded with valid proof of deposit of Earnest Money and required tender fee, shall be rejected forthwith by the Employer as non-responsive. The bidder shall not have any claim in this regard.
- iii. The Earnest Money of unsuccessful bidders will be returned soon after approval of technical bid by the competent authority and latest on or before the 30th day after award of the contract.
- iv. The Earnest Money of the successful Bidder will be discharged when the Bidder has signed the Agreement and furnished the required Performance Security.
- v. The Bid shall be kept valid for **120 days from last date of submission of bid**. A bid valid for a shorter period shall be rejected by the Employer as non-responsive.
- vi. In exceptional circumstances, prior to expiry of the original time limit, the Employer may request that the bidders may extend the period of validity for a specified additional period. The request and the bidders' responses shall be made in writing. A bidder may refuse the request without forfeiting his Earnest Money.

#### **3.9.3 The Employer reserves the right to:**

- i. Amend the scope and value of any Contract to be Bid, in which event the Contract will only be Bid among those pre-qualified Bidders who meet the requirements of the Contract as amended;
- ii. Reject or accept any application/bid; and
- iii. Cancel the pre-qualification process and reject all Applications/bids.
- iv. Cancel the entire bid process.
- v. The Employer shall neither be liable for any such actions nor be under any obligation to inform the Bidder of the grounds for them.

#### **3.9.4**

- i. The Bidder will be advised by the Employer or his representative in writing or by fax/e-mail/SMS, within 90 days of the date for submission of bids, of the result of their application and of the names of the pre-qualified Bidders without being assigned any reason for the Employer's decision.
- ii. If the Bidder feels that technical credentials of his own or other Bidders have been wrongly evaluated/verified, he may raise objections within 2 (Two) working days from the date of uploading of result. Opening of financial bid will be scheduled accordingly. No requests/objections shall be entertained beyond above limit, else it may be treated as an obstruction in tender process and shall be dealt with accordingly.

**3.9.5** The Employer reserves the right to verify and seek clarification of the information furnished by any/all Bidders to make an informed decision.

### **3.10 QUALIFIED BIDDERS:**

U.P. Jal Nigam (Urban) will decide which Bidders are qualified and will inform them through e- tender portal. Qualified contractors will be given an invitation to participate in opening of Financial Bid of the tender at the date and time to be specified in the intimation. This information will be disseminated on e-tender portal.

- 3.11** Even though the Bidders are pre-qualified, they are subject to be disqualified if they have:
- 3.11.1 Made misleading or false representations in the forms, statements and attachments submitted in proof of the qualification requirements, and/or
  - 3.11.2 Participated in the previous bidding for the same work and had quoted unreasonably high/low bid prices and could not furnish rational justification to the Employer. and/or
  - 3.11.3 Record of past poor performance such as abandoning the work, not properly completing the contract, inordinate delays in completion, or financial failures, etc.
  - 3.11.4 The bidder's litigation history will be examined and if the Employer, in its opinion, finds the litigation history against the interest of work, such bidder/bidders may be disqualified.

## **CHAPTER-4**

### **EVALUATION AND QUALIFICATION PROCEDURE**

#### **4.1. Evaluation criterion of applications for pre-qualification:**

The pre-qualification document shall be examined to ascertain whether the applications:

- I. Fulfil responsiveness criteria of the Bid i.e. deposit/uploading of proof of earnest money deposit, tender fees, standard affidavit in prescribed form 'I-C'.
- II. Meet the eligibility requirements,
- III. Have been properly prepared & signed,
- IV. Contain all the details called for and are in proper format.

Assessment of the firms who have applied for the pre-qualification, will also include the following items:

Submission of the bidders will be evaluated in detail in the second stage, regarding following factors.

1. Financial status of the firm including annual turnover, solvency, net worth, and works in hand, financial arrangements proposed viz. own resources/bank credits etc.
2. Resources of the firm in respect of personnel, equipment and plants.
3. The experience of the firms for works of similar nature.

**4.2.** The bidder should state in detail about the contracts where delay has occurred, the period of delay and the reasons thereof. Details of works that have been abandoned for reasons whatsoever should also be furnished. In case the bidder or any known partners were ever black listed the same should be indicated.

**4.3.** Qualified bidders will be called for opening of financial bid.

**4.3.1.** U.P. Jal Nigam(Urban), however, reserves the right to restrict the list of such qualified contractors to any number deemed suitable by it.

**4.4.** Examination of Bids and Determination of Responsiveness:

**4.4.1.** During the detailed evaluation of “Technical Bids”, the Employer will determine whether each Bid (a) meets the eligibility criteria defined in Chapter-3; (b) has been properly signed; (c) is accompanied by the required securities; and (d) is substantially responsive to the requirements of the bidding documents. During the detailed evaluation of the “Financial Bids”, the responsiveness of the bids will be further determined with respect to the remaining bid conditions, i.e., priced bill of quantities, technical specifications and drawings.

**4.4.2.** A substantially responsive “Financial Bid” is one that conforms to all the terms, conditions, and specifications of the bidding documents, without material deviation or reservation. A material deviation or reservation is one (a) which affects in any substantial way the scope, quality, or performance of the Works; (b) which limits in any substantial way, inconsistent with the bidding documents, the Employer’s rights or the Bidder’s obligations under the Contract; or (c) whose rectification would affect unfairly the competitive position of other bidders presenting substantially responsive bids.

**4.4.3.** If a “Financial Bid” is not substantially responsive, it will be rejected by the Employer, and may not subsequently be made responsive by correction or withdrawal of the nonconforming deviation or reservation.

**4.4.4.** The conditional bids shall be treated as non-responsive forthwith.

**4.5.** If the Bid of the successful Bidder is seriously unbalanced in relation to the Engineer’s estimate of the cost of work to be performed under the contract, the Employer may require the Bidder to produce detailed price analyses for any or all items of the Bill of Quantities, to demonstrate the internal consistency of those prices with the construction methods and schedule proposed. After evaluation of the price analyses, the Employer may require that the amount of the performance

security be increased at the expense of the successful Bidder to a level sufficient to protect the Employer against financial loss in the event of default of the successful Bidder under the Contract. The amount of the increased performance security shall be decided at the sole discretion of the Employer, which shall be final, binding and conclusive on the bidder.

- 4.6.** Stamp duty charges shall be borne by the tenderer as applicable at the time of award of the contract. The contract agreement will be executed on non-judicial stamp paper of the value of Rs. 100/- along with Rs. 2/- Revenue stamp.

## CHAPTER-5

### PREPARATION & SUBMISSION OF e-Bids

*(For guidance purposes only. The Bidder is advised to familiarize himself with Terms and Conditions of NIT, Bid document and process of bid submission on e-tender portal on their own. U.P. Jal Nigam bears no responsibility for incorrect submission of bid. The procurement portal is updated continuously therefore the bidder must keep himself updated.)*

#### **4.1. Documents Constituting the e-Bid**

The e-Bids prepared by the Bidder shall comprise the following components:e-Bids will comprise of:

- a) Technical proposal submission forms
- b) Financial proposal submission forms

#### **4.2. Documents Establishing Bidder's Qualification**

The Bidder shall furnish, as part of Technical Proposal, documents establishing the qualification to perform the Contract. The documentary evidence in support of the information furnished should be submitted by the Bidder electronically in the PDF format. The Bidder's eligibility criteria and selection procedure are defined in previous Chapters.

#### **4.3. Format and Signing of e-Bids**

The Bidder shall prepare one electronic copy for the e-Bids.

**All the pages/ documents of the e-Bid shall also be signed manually by the person authorized to sign the e-Bids before converting them into PDF and uploading them as bidding documents.** If for some reason the uploaded documents/files are corrupted/ not able to be opened after downloading, its responsibility shall lie with the Bidder only.

#### **4.4. Submission of e-Bids:**

The e-Bid Submission module of e-tender portal "<http://etender.up.nic.in>" enables the Bidder to submit the e-Bid online against the e-tender published by U.P. Jal Nigam. Bid Submission can be done only from the Bid Submission start date and time till the e-Bid Submission end date and time given in the e-Bid. **Bidders should start the Bid Submission process well in advance so that they can submit their e-Bid in time.** The Bidders should submit their Bids considering the server time displayed in the e-tender portal. This server time is the time by which the Bid submission activity will be allowed till the permissible time on the last/end date of submission indicated in the e-tender schedule. Once the Bid submission date and time is over, the Bidders cannot submit their e-Bid. For delay in submission of e-Bids due to any reasons what so ever, the Bidders shall only be held responsible.

The Bidders are advised to follow the following instructions for submission of their e-Bids:

For participating in e-tender through the e-Bidding system, it is necessary for the Bidders to be the registered users of the e-tender portal <https://etender.up.nic.in>. For this, the Bidders have to register themselves by depositing appropriate fee in the office of U.P. Electronics Corporation Limited, 10, Ashok Marg, Lucknow-226 001 for getting a valid User ID and password and the required training/ assistance etc. on e-tender portal <http://etender.up.nic.in>. The Bidders may contact U.P. Electronics Corporation Limited for further assistance.

In addition to the normal registration, the Bidder has to register with his/her Digital Signature Certificate (DSC) in the e-Bidding system and subsequently he/she will be allowed to carry out his/her e-Bids submission activities. Registering the Digital Signature Certificate (DSC) is a onetime activity till its validity. Before proceeding to register his/her DSC, the Bidder should first log on to the e-Bidding system using the User Login option on the home page with the Login Id and Password with which he/ she has registered as enumerated in the preceding paragraph above.

For successful registration of DSC on e-Procurement portal <http://etender.up.nic.in> the Bidder must ensure that he/she should possess Class-2/ Class-3 DSC issued by any one of certifying authorities approved by Controller of Certifying Authorities, U.P. Jal Nigam of India. The Bidder may also apply to office of U.P. Electronics Corporation Limited, (UPLC) for getting DSC at the address given in the preceding paragraph above on a prescribed form available at UPLC's website [www.uplc.in](http://www.uplc.in) along with the required payment of fee. The Bidder is also advised to register his/her DSC on e-tender portal well in advance before Bid submission end date so that he/she should not face any difficulties while submitting his/her e-Bid against this e-tender. The Bidder can perform User Login registration/creation and DSC registration exercise as described in preceding paragraphs above even before e-Bid submission date starts. The U P Jal Nigam shall not be held responsible if the Bidder tries to submit his/her e-Bids at the last moment before end date of submission but could not submit due to DSC registration or any other technical problems.

The Bidder can search for active Bids through "Search Active Bids" link, select a Bid in which he/she is interested in and then move it to „My Bids“ folder using the options available in the e- Bid Submission menu. After selecting and viewing the Bid, for which the Bidder intends to e- Bid, from "My Bids" folder, the Bidder can place his/her Bid by clicking "Pay Offline" option available at the end of the view Bid details form. Before this, the Bidder should download the Bid document and study them carefully. The Bidder should keep all the documents ready as per the requirements of e-Bid document in the PDF format.

After clicking the „Pay Offline“ option, the Bidder will be redirected to the Terms and Conditions page. The Bidder should read the Terms & Conditions before proceeding to fill in the Processing Fee offline payment details. After entering and saving the Processing fee details, the Bidder should click "Encrypt & Upload" option given in the offline payment details form so that "Bid Document Preparation and Submission" window appears to upload the required documents Technical Proposal Submission Form etc. of this e-tender document. The details of the Demand Draft or any other accepted instrument which is to be physically sent/submitted in original before/after Bid submission end date and time, should tally with the details available in the scanned copy and the data entered during e-Bid submission time otherwise the e-Bid submitted will not be accepted.

Before uploading, the Bidder has to select the relevant Digital Signature Certificate. He may be prompted to enter the Digital Signature Certificate password, if necessary. For uploading, the Bidder should click "Browse" button against each document label in technical schedules/packets and then upload the relevant PDF files already prepared and stored in the Bidder's computer. The required documents for each document label of Technical. Schedules/packets can be clubbed together to make single different files for each label.

The Bidder should click "Encrypt" next for successfully encrypting and uploading of required documents. During the above process, the Bid documents are digitally signed using the DSC of the Bidder and then the documents are encrypted/locked electronically with the DSC's of the Bid openers to ensure that the Bid documents are protected, stored and opened by concerned Bid openers only.

After successful submission of e-Bids, a page giving the summary of e-Bid submission will be displayed confirming end of e-Bid submission process. The Bidder can take a printout of the Bid summary using the "Print" option available in the window as an acknowledgement for future reference.

#### **4.5. Deadline for Submission of e-Bids**

e-Bids must be submitted by the Bidders on e-tender portal <https://etender.up.nic.in>, not later than the date and time specified in this e-tender notice document.

The UPJN may extend this deadline for submission of e-Bids by amending the e-tender document, in which case all rights and obligations of the UPJN and Bidders previously subject to the deadline will

thereafter be subject to the deadline as extended.

UPJN shall not consider any request for date-extension for e-Bid-submission on account of late downloading of e-tender (RFP) by any prospective Bidder. E-Bids should be uploaded on e-tender portal <http://etender.up.nic.in> on or before **the scheduled date and time**.

#### **4.6. Late e-Bids**

The server time indicated in the Bid Management window on the e-tender portal <https://etender.up.nic.in> will be the time by which the e-Bids submission activity will be allowed till the permissible date and time scheduled in the e-tender. Once the e-Bids submission date and time is over, the Bidder cannot submit his/ her Bid. Bidder has to start the e-Bid Submission well in advance so that the submission process passes off smoothly. The Bidder only, will be held responsible if his/ her e-Bids are not submitted in time due to any reasons.

#### **4.7. Withdrawal and Resubmission of e-Bids.**

At any point of time, a Bidder can withdraw his/ her e-Bids submitted online before the e-Bids submission end date and time (**if allowed**). For withdrawing, the Bidder should first log in using his/ her Login ID and Password and subsequently by his/ her Digital Signature Certificate on the e-procurement portal <https://etender.up.nic.in>. The Bidder should then select "My Bids" option in the Bid Submission menu. The page listing all the Bids submitted by the Bidder will be displayed. Click "View" to see the details of the Bid to be withdrawn. After selecting the "Bid Withdrawal" option, the Bidder has to click "Yes" to the message "Do you want to withdraw this Bid?" displayed in the Bid Information window for the selected Bid. The Bidder also has to enter the Bid Withdrawing reasons and upload the letter giving the reasons for withdrawing before clicking the "Submit" button. The Bidder has to confirm again by pressing "Ok" button before finally withdrawing his/ her selected Bid. Once the Bidder has withdrawn his/ her Bid he/she cannot re-submit this Bid again.

The Bidder can resubmit his/ her e-Bids as and when required till the Bid submission end date and time. The e-Bids submitted earlier will be replaced by the new one. The payment made by the Bidder earlier will be used for revised e-Bids and the new Bid submission summary generated after the successful submission of the revised e-Bids will be considered for evaluation purposes. For resubmission, the Bidder should first log in using his/ her Login ID and Password and subsequently by his/ her Digital Signature Certificate on the e-procurement portal <http://etender.up.nic.in>. The Bidder should then select "My Bids" option in the Bid Submission menu. The page listing all the Bids submitted by the Bidder will be displayed. Click "View" to see the details of the Bid to be resubmitted. After selecting the "Bid Resubmission" option, click "Encrypt & Upload" to upload the revised e-Bids documents.

The Bidders can submit their revised Bids as many times as possible by uploading their e-Bids documents within the scheduled date & time for submission of e-Bids.

No e-Bids can be resubmitted subsequently after the deadline for submission of e-Bids.

#### **4.8. Receipt and Opening of e-Bids by the Purchaser/TIA**

Bidders are advised to submit their e-bids in "Two-Bid" system or as applicable with Technical and Financial bids separately on e-tender portal.

**Please note that prices should not be quoted in the Technical Bid.** The Prices should be quoted in the Financial Bid only. On receipt on e-tender portal, the technical proposals will be opened first.

UPJN will open all e-Bids, in the presence of bidder's authorized representatives who choose to attend at **scheduled date and time at designated place**. The bidder's representatives who are present shall sign a register evidencing their attendance. In the event of the specified date of e-Bid opening being declared a holiday, the e-Bids shall be opened at the appointed time and place on the next working day. The name of such bidders not meeting the qualification requirements shall be notified subsequently.

After evaluation of technical e-Bids, UPJN shall notify those bidders whose e-Bids were considered non-responsive to the Conditions of the Contract and not meeting the Qualification Requirements indicating that they did not technically qualify for selection. UPJN, through e-bid portal, will simultaneously notify the bidders, whose technical e-Bids were considered acceptable and have been short listed for opening of their financial e-bids.

## SECTION-3

ANNEXURE-1

### CHECK LIST REQUIRED FOR SUBMISSION OF DOCUMENTS.

Sl. No.	Check Item	Yes/No	Page Nos.	
			From	To
1	Tender Fee			
2	Earnest Money/Bid Security (In case of BG:- as per <b>Annexure-6</b> )			
3	Integrity Pact as per <b>Annexure-2</b>			
4	General Information in <b>Form-I</b>			
5	Declaration Form in <b>Form-IA</b>			
6	Declaration on <b>Form - I B</b> . (Affidavit of Bid Validity)			
7	Standard Affidavit on <b>Form- I-C</b>			
8	Financial information in <b>Form- II (A)</b>			
9	Bank Solvency Certificate issued by a prescribed Bank on <b>Form II-B or Haisiyat Certificate</b> issued by District Magistrate.			
10	List of similar works executed during last 10 years as per <b>Form-III &amp; IIIA</b> . (See <b>Clause 3.1 ITB</b> ) *			
11	Details of work which are in progress/awarded/bid have been submitted as on <b>the date of bid submission. Form-IV</b>			
12	Details of technical and administrative personnel with bidder in <b>Form-V</b>			
13	Format for performance report of eligible works in <b>Form-VI</b>			
14	Details of construction plants and equipments with the bidder in <b>Form-VII</b>			
15	Litigation history on <b>Form- VIII</b> including declaration regarding black listing/debarment from all the bidders including all JV participants			
16	Letter comprising Bid - <b>Form-IX</b>			
17	Proof of Registration with GST EPF, ESI etc.(As issued by authority).			
18	All other documents required for Partnership/Limited/JV firms as described in relevant paras. ( <b>Annexures-3 to 5</b> )			
19	Income Tax Returns.			
20	Audited Balance sheets as per NIT and ITB			
21	(Partnership Deed, Memorandum of Association and Articles of Association as the case may be)			
22	Any other document required in terms of the Bid document: (Please specify and add lines below)			
23	Financial Bid/BOQ.		NA	NA

\* **Note-** The bidder must fill up following information for works which he considers to be an "eligible work" as per terms of the document. These will be considered while evaluating the Technical Eligibility of the Bidder.

Sl. No.	Name of Work	Value of work done (Rs. Lacs)	Whether completed and commissioned (Yes/No)	Authority by whom Experience Certificate has been issued	Page Nos.	
					From	To
1						
2						
3						

Signature of the Bidder(s)

**INTERGRITY PACT**

To,  
.....  
.....  
.....

**Sub: NIT No .... for the work ....**

Dear Sir,

It is here by declared that UPJN is committed to follow the principle of transparency, equity and competitiveness in public procurement.

The subject Notice Inviting Tender (NIT) is an invitation to offer made on the condition that the Bidder will sign the integrity Agreement, which is an integral part of tender/bid documents, failing which the tenderer/bidder will stand disqualified from the tendering process and the bid of the bidder would be summarily rejected.

This declaration shall form part and parcel of the Integrity Agreement and signing of the same shall be deemed as acceptance and signing of the Integrity Agreement on behalf of the UPJN (Urban).

Yours faithfully,

..... Engineer,  
.....  
U P Jal Nigam (Urban), .....

**INTEGRITY PACT**

To,

..... Engineer,

.....

U P Jal Nigam (Urban), .....

**Sub: Submission of Tender for the work of . . ....**

Dear Sir,

I/We acknowledge that UPJN is committed to follow the principles thereof as enumerated in the Integrity Agreement enclosed with the tender/bid document.

I/We agree that the Notice Inviting Tender (NIT) is an invitation to offer made on the condition that I/We will sign the enclosed integrity Agreement, which is an integral part of tender documents, failing which I/We will stand disqualified from the tendering process. We acknowledge that THE MAKING OF THE BID SHALL BE REGARDED AS AN UNCONDITIONAL AND ABSOLUTE ACCEPTANCE of this condition of the NIT.

I/We confirm acceptance and compliance with the Integrity Agreement in letter and spirit and further agree that execution of the said Integrity Agreement shall be separate and distinct from the main contract, which will come into existence when tender/bid is finally accepted by UPJN. I/We acknowledge and accept the duration of the Integrity Agreement, which shall be in the line with Article-1 of the enclosed Integrity Agreement.

I/We acknowledge that in the event of my/our failure to sign and accept the Integrity Agreement, while submitting the tender/bid, UPJN shall have unqualified, absolute and unfettered right to disqualify the tenderer /bidder and reject the tender/bid in accordance with terms and conditions of the tender/ bid.

Yours faithfully

(Duly authorized signatory of the Bidder)

To be signed by the bidder and same signatory competent / authorized to sign the relevant contract.

## INTEGRITY AGREEMENT

This Integrity Agreement is made at ..... on this ..... day of 20 .....

BETWEEN

UPJN represented through

.....

(Name of Division)

UPJN (Urban), ..... (Hereinafter referred as the 'Principal/Owner', which expression shall unless repugnant to the meaning or context hereof include its successors and permitted assigns)

AND

.....

(Name and Address of the Individual/firm/Company)

through ..... (Hereinafter referred to as the (Details of duly authorized signatory) "Bidder/Contractor" and which expression shall unless repugnant to the meaning or context hereof include its successors and permitted assigns)

### **Preamble**

WHEREAS the Principal/ Owner has floated the Tender (NIT No ..... ) (Hereinafter referred to as "Tender/Bid") and intends to award, under laid down organizational procedure, contract for.....

(Name of work)

hereinafter referred to as the "Contract".

AND WHEREAS the Principal/Owner values full compliance with all relevant laws of the land, rules, regulations, economic use of resources and of fairness/transparency in its relation with its Bidder(s) and Contractor(s).

AND WHEREAS to meet the purpose aforesaid both the parties have agreed to enter into this Integrity Agreement (hereinafter referred to as "Integrity Pact" or "Pact"), the terms and conditions of which shall also be read as integral part and parcel of the Tender/Bid documents and Contract between the parties. NOW, THEREFORE, in consideration of mutual covenants contained in this Pact, the parties hereby agree as follows and this Pact witnesses as under:

### **Article 1: Commitment of the Principal/Owner**

- (1). The Principal/Owner commits itself to take all measures necessary to prevent corruption and to observe the following principles:
  - a. No employee of the Principal/Owner, personally or through any of his/her family members, will in connection with the Tender, or the execution of the Contract, demand, take a promise for or accept, for self or third person, any material or immaterial benefit which the person is not legally entitled to.
  - b. The Principal/Owner will, during the Tender process, treat all Bidder(s) with equity and reason. The Principal/Owner will, in particular, before and during the Tender process, provide to all Bidder(s) the same information and will not provide to any Bidder(s) confidential/additional information through which the Bidder(s) could obtain an advantage in relation to the Tender process or the Contract execution.
  - c. The Principal/Owner shall Endeavour to exclude from the Tender process any person, whose conduct in the past has been of biased nature.
- (2). If the Principal/Owner obtains information on the conduct of any of its employees which is a criminal offence under the Indian Penal code (IPC)/Prevention of Corruption Act, 1988 (PC Act) or is in violation of the principles herein mentioned or if there be a substantive suspicion in this regard, the Principal/Owner will inform the competent authority and in addition can also initiate disciplinary actions as per its internal laid down policies and procedures.

### **Article 2: Commitment of the Bidder(s)/Contractor(s)**

- (1). It is required that each Bidder/Contractor (including their respective officers, employees and agents) adhere to the highest ethical standards, and report to U.P. Jal Nigam/U.P. Jal Nigam all suspected acts of fraud or corruption or Coercion or Collusion of which it has knowledge or becomes aware, during the tendering process and throughout the negotiation or award of a contract.

- (2). The Bidder(s)/Contractor(s) commits himself to take all measures necessary to prevent corruption. He commits himself to observe the following principles during his participation in the Tender process and during the Contract execution:
- a. The Bidder(s)/Contractor(s) will not, directly or through any other person or firm, offer, promise or give to any of the Principal/Owner's employees involved in the Tender process or execution of the Contract or to any third person any material or other benefit which he/she is not legally entitled to, in order to obtain in exchange any advantage of any kind whatsoever during the Tender process or during the execution of the Contract.
  - b. The Bidder(s)/Contractor(s) will not enter with other Bidder(s) into any undisclosed agreement or understanding, whether formal or informal. This applies in particular to prices, specifications, certifications, subsidiary contracts, submission or non-submission of bids or any other actions to restrict competitiveness or to cartelize in the bidding process.
  - c. The Bidder(s)/Contractor(s) will not commit any offences under the relevant IPC/PC Act. Further the Bidder(s)/Contractor(s) will not use improperly, (for the purpose of competition or personal gain), or pass on to others, any information or documents provided by the Principal/Owner as part of the business relationship, regarding plans, technical proposals and business details, including information contained or transmitted electronically.
  - d. The Bidder(s)/Contractor(s) of foreign origin shall disclose the names and addresses of agents/representatives in India, if any. Similarly, Bidder(s)/Contractor(s) of Indian Nationality shall disclose names and addresses of foreign agents/representatives, if any. Either the Indian agent on behalf of the foreign principal or the foreign principal directly could bid in a tender but not both. Further, in cases where an agent participate in a tender on behalf of one manufacturer, he shall not be allowed to quote on behalf of another manufacturer along with the first manufacturer in a subsequent/parallel tender for the same item.
  - e. The Bidder(s)/Contractor(s) will, when presenting his bid, disclose any and all payments he has made, is committed to or intends to make to agents, brokers or any other intermediaries in connection with the award of the Contract.
- (3). The Bidder(s)/Contractor(s) will not instigate third persons to commit offences outlined above or be an accessory to such offences.
- (4). The Bidder(s)/Contractor(s) will not, directly or through any other person or firm indulge in fraudulent practice means a willful misrepresentation or omission of facts or submission of fake/forged documents in order to induce public official to act in reliance thereof, with the purpose of obtaining unjust advantage by or causing damage to justified interest of others and/or to influence the procurement process to the detriment of U.P. Jal Nigam interests.
- (5). The Bidder(s)/Contractor(s) will not, directly or through any other person or firm use Coercive Practices (means the act of obtaining something, compelling an action or influencing a decision through intimidation, threat or the use of force directly or indirectly, where potential or actual injury may befall upon a person, his/ her reputation or property to influence their participation in the tendering process).

### **Article 3: Consequences of Breach**

Without prejudice to any rights that may be available to the Principal/Owner under law or the Contract or its established policies and laid down procedures, the Principal/Owner shall have the following rights in case of breach of this Integrity Pact by the Bidder(s)/Contractor(s) and the Bidder/ Contractor accepts and undertakes to respect and uphold the Principal/Owner's absolute right:

- (1). If the Bidder(s)/Contractor(s), either before award or during execution of Contract has committed a transgression through a violation of Article 2 above or in any other form, such as to put his reliability or credibility in question, the Principal/Owner after giving 14 days notice to the contractor shall have powers to disqualify the Bidder(s)/Contractor(s) from the Tender process or terminate/determine the Contract, if already executed or exclude the Bidder/Contractor from future contract award processes. The imposition and duration of the exclusion will be determined by the severity of transgression and determined by the Principal/Owner. Such exclusion may be forever or for a limited period as decided by the Principal/Owner.
- (2). Forfeiture of EMD/Performance Guarantee/Security Deposit: If the Principal/Owner has disqualified the Bidder(s) from the Tender process prior to the award of the Contract or terminated/determined the

Contract or has accrued the right to terminate/determine the Contract according to Article 3(1), the Principal/Owner apart from exercising any legal rights that may have accrued to the Principal/Owner, may in its considered opinion forfeit the entire amount of Earnest Money Deposit, Performance Guarantee and Security Deposit of the Bidder/Contractor.

- (3). Criminal Liability: If the Principal/Owner obtains knowledge of conduct of a Bidder or Contractor, or of an employee or a representative or an associate of a Bidder or Contractor which constitutes corruption within the meaning of IPC Act, or if the Principal/Owner has substantive suspicion in this regard, the Principal/Owner will inform the same to law enforcing agencies for further investigation.

#### **Article 4: Previous Transgression**

- (1). The Bidder declares that no previous transgressions occurred in the last 5 years with any other Company in any country confirming to the anti-corruption approach or with Central U.P. Jal Nigam or State U.P. Jal Nigam or any other Central/State Public Sector Enterprises in India that could justify his exclusion from the Tender process.
- (2). If the Bidder makes incorrect statement on this subject, he can be disqualified from the Tender process or action can be taken for banning of business dealings/ holiday listing of the Bidder/Contractor as deemed fit by the Principal/Owner.
- (3). If the Bidder/Contractor can prove that he has resorted to and recouped the damage caused by him and has installed a suitable corruption prevention system, the Principal/Owner may, at its own discretion, revoke the exclusion prematurely.

#### **Article 5: Equal Treatment of all Bidders/Contractors/Subcontractors:**

- (1). The Bidder(s)/Contractor(s) undertake(s) to demand from all subcontractors a commitment in conformity with this Integrity Pact. The Bidder/Contractor shall be responsible for any violation(s) of the principles laid down in this agreement/Pact by any of its Subcontractors/sub-vendors.
- (2). The Principal/Owner will enter into Pacts on identical terms as this one with all Bidders and Contractors.
- (3). The Principal/Owner will disqualify Bidders, who do not submit, the duly signed Pact between the Principal/Owner and the bidder, along with the Tender or violate its provisions at any stage of the Tender process, from the Tender process.

#### **Article 6- Duration of the Pact**

This Pact begins when both the parties have legally signed it. It expires for the Contractor/Vendor 12 months after the completion of work under the contract or till the continuation of defect liability period, whichever is more and for all other bidders, till the Contract has been awarded. If any claim is made/lodged during the time, the same shall be binding and continue to be valid despite the lapse of this Pact as specified above, unless it is discharged/determined by the Competent Authority, UPJN.

#### **Article 7- Other Provisions**

- (1) This Pact is subject to Indian Law, place of performance and jurisdiction is the Head quarters of the Division of the Principal/Owner, who has floated the Tender.
- (2) Changes and supplements need to be made in writing. Side agreements have not been made.
- (3) If the Contractor is a partnership or a consortium, this Pact must be signed by all the partners or by one or more partner holding power of attorney signed by all partners and consortium members. In case of a Company, the Pact must be signed by a representative duly authorized by board resolution.
- (4) Should one or several provisions of this Pact turn out to be invalid; the remainder of this Pact remains valid. In this case, the parties will strive to come to an agreement to their original intentions.
- (5) It is agreed term and condition that any dispute or difference arising between the parties with regard to the terms of this Integrity Agreement / Pact, any action taken by the Owner/Principal in accordance with this Integrity Agreement/ Pact or interpretation thereof shall not be subject to arbitration.

#### **Article 8- LEGAL AND PRIOR RIGHTS**

All rights and remedies of the parties hereto shall be in addition to all the other legal rights and remedies belonging to such parties under the Contract and/or law and the same shall be deemed to be cumulative and not alternative to such legal rights and remedies aforesaid. For the sake of brevity, both the Parties agree that this Integrity Pact will have precedence over the Tender/Contract documents with regard any of the provisions covered under this Integrity Pact.

IN WITNESS WHEREOF the parties have signed and executed this Integrity Pact at the place and date first above mentioned in the presence of following witnesses:

..... (For and on behalf of Principal/Owner)

.....(For and on behalf of Bidder/Contractor)

WITNESSES:

1(signature, name and address)

2(signature, name and address)

**JOINT BIDDING AGREEMENT**

(The J.V. Agreement should be made on a Rs.100/- Non-Judicial Stamp paper, purchased in favour of the J.V. firm and there should not be more than six months time, from the date of purchase of those Non-Judicial papers and execution of the J.V. Agreement, on it)

**JOINT BIDDING AGREEMENT****BETWEEN**

M/s..... having its registered office at..... (hereafter referred to as  
.....) acting as the Lead Partner of the first part.

And

M/s.....having its registered office at ..... (hereafter referred to as „  
.....“) in the capacity of a Joint Partner of the other part. **(add for more partners)**

Now, the Joint Venture formed by all the parties i.e. \_\_\_\_\_ and \_\_\_\_\_ and ..... will be known as M/s \_\_\_\_\_ (JV).

The expressions of ..... and ..... shall whatever the context admits, mean and include their respective legal representatives, successors-in-interest and assigns and shall collectively be referred to as “the Parties” and individually as “the Party”

1. WHEREAS; UP JAL NIGAM has invited bids for ..... (insert name of work and Tender Notice No.)  
.....  
.....”

And Whereas, the above parties to the Joint Venture intend to submit bid in the name of the said JV, we M/s....., the lead partner and M/s....., ..... , the Joint Partners herewith sign the above formal JV agreement for registration of the above joint venture viz M/s..... and for entering into contract Agreement with UP JAL NIGAM (URBAN), the “Employer”.

2. NOW, THEREFORE, THE PARTIES AGREE AS FOLLOWS:
  - a. The „Parties“ have studied the documents, JV guidelines and have agreed to participate in submitting the „Tender“ jointly;
  - b. M/s....., the Lead Partner, shall be the lead member of the JV for all intents and purposes and shall represent the Joint Venture in its dealing with the Employer. The lead member shall be authorized to sign and submit all documents and subsequent clarifications, if any, to the Employer. However, he will not submit any such proposals, clarifications or commitments before securing the written clearance of the other partner(s) which shall be expeditiously given by M/s..... , ..... , to M/s.....
  - c. The lead member shall sign bid documents, submit the bid, sign the agreement or enter into contract in respect of the work awarded, to receive payment, to witness joint measurement of work done, to sign measurement books and similar such action in respect of the said contract. All notices/correspondences with respect to the contract would be sent only to the lead member of the JV firm.
3. The „Parties“ have resolved that the distribution of share, responsibilities, profits, losses and remuneration shall be as under:

- a) Lead Partner’s share..... %;

Name .....

Responsibilities:

i) .....

ii) .....

iii) .....

(Technical, Financial & other obligations)

b) Other Joint Venture Partner's share -----%

Name .....

Responsibilities:

i) .....

ii) .....

iii)

(Technical, Financial & other obligations)

4. The constitution of JV firm shall not be altered during the currency of the bid/contract as the case may be except when modification become inevitable due to succession laws etc. provided that the minimum eligibility criteria are not got vitiated. Failure to observe this stipulation shall be deemed to be breach of contract, which will entitle the employer. the UP JAL NIGAM to take all consequential action as per contract conditions. We also undertake that the lead member shall continue to be the lead member during the period of contract.

**5. JOINT AND SEVERAL RESPONSIBILITIES:**

The parties undertake that they shall be jointly and severally liable to the UP JAL NIGAM or his assignees, for satisfactory execution and completion of the Project work in accordance with General and Special conditions of contract. The JV members shall also be liable jointly and severally for the loss, damages that may be caused to the UP JAL NIGAM and during the course of execution of the contract or due to non-execution of the contract or part thereof. The parties solemnly affirm and declare th\*at every possible care will be taken by them for ensuring satisfactory execution and completion of the work awarded under the contract.

**6. ASSIGNMENT AND THIRD PARTIES:**

No member of the Joint Venture firm shall have the right to assign or transfer the interest, right or liability in the contract without the written consent of the other members and that of the Employer (UP JAL NIGAM) in respect of the said tender/contract.

**7. GUARANTEES AND BONDS**

The lead partner shall furnish all bonds/guarantees to the UP JAL NIGAM (URBAN) in the name of J.V. and on behalf of the J.V., which shall be legally binding on all the partners of the J.V.

**8. USE OF MACHINERY, INSTRUMENT, LABOUR FORCE etc.**

For the execution of the respective portions of works, the parties shall make full arrangements to bring the required finance, plants and equipment, materials, manpower and other resources. However, the parties here to undertake that whatever the machinery, instruments, labour force, (including unskilled, skilled, inspectors, Engineer etc.) they possess at the time of entering into Joint Venture Agreement or which subsequently shall come in their possession and if such machinery, instruments, labor force is required for the speedy and efficient execution of any portion of the work, the party/parties having the control over the said machinery, instruments, labour force etc. without having any regard to their share of profit and loss agreed to between the parties in Joint Venture Agreement shall hand over the same which shall be placed at the disposal of the other party actually executing that portion of the work at mutually agreed terms for the purpose of execution of the contract without any hindrance and obstacle.

**9. DURATION OF JOINT BIDDING AGREEMENT:**

It shall be valid during the entire currency of the contract including the period of extension if any and the defect liability period after the work is completed, handed over and Security Deposit is released.

**10. Name and address of the J.V. firm**

(indicate Address, Telephone No. and Fax Numbers of the J.V. firm)

11. **Governing Laws:** The J.V. Agreement shall in all respect be governed by and interpreted in

accordance with Indian Laws.

- 12. We undertake that if Memorandum of Agreement (MoA) & Articles of Association (AoA) of Firm is inconsistency with provisions of JV Agreement, then the MoA & AoA shall be amended accordingly.

**Declaration: -**

It is to certify that we have not been blacklisted or debarred by UP JAL NIGAM or any other Ministries U.P. Jal Nigams of the Govt of India/State Govt./ Govt. undertakings etc. from participation in tenders/contracts in the past either in our individual capacity or the JV Firm or Partnership firm in which we were members/partners.

Lead Partner

(Name & Address)

Name & Address of the JV Firm: -

.....

Other Partner

(Name & address)

IN WITNESS WHEREOF, THE PARTIES, have executed this J.V. Agreement \_\_\_\_\_the day, \_\_\_\_\_month and \_\_\_\_\_year.

For M/s.....

.....

.....

.....

(Seal)

Witness:

1. .... (Name & Address.....).

2. .... (Name & Address.....).

Place:

Date:

(The J.V. Agreement should be notarized first and thereafter it has to be got registered before the registrar of Companies under Companies Act or before the Registrar/Sub registrar under the relevant Registration Acts)

**FORMAT FOR POWER OF ATTORNEY TO LEAD PARTNER OF JOINT VENTURE (JV)**  
(To be executed on non-judicial stamp paper of the appropriate value in accordance with relevant stamp Act. The stamp paper to be in the name of the company who is issuing the Power of Attorney)

**POWER OF ATTORNEY**

Whereas, U P Jal Nigam (Urban) has invited Tender for the work of .....

Whereas, the members of the Joint Venture comprising of M/s....., M/s....., and ..... are interested in submission of bid for the work ..... (insert name of work ..... in accordance with the terms and conditions contained in the bidding documents.

Whereas, it is necessary for the members of the Joint Venture to designate one of them as the Lead Partner, with all necessary power and authority to do, for and on behalf of the Joint Venture, all acts, deeds and things as may be necessary in connection with the Joint Venture's bid for the project, as may be necessary in connection the Joint Venture's bid for the project.

NOW THIS POWER OF ATTORNEY WITNESSETH THAT:

We, M/s....., hereby designate M/s ..... , being one of the partners of the Joint Venture, as the lead partner of the Joint Venture, to do on behalf of the Joint Venture, all or any of the acts, deeds or things necessary or incidental to the Joint Venture's Tender for the contract, including submission of Tender, participating in conferences, responding to queries, submission of information/documents and generally to represent the Joint Venture in all its dealings with the UP JAL NIGAM (URBAN) or any other Government Agency or any person, in connection with the contract for the said work until culmination of the process of Tendering till the contract agreement is entered into with the UP JAL NIGAM (URBAN) and thereafter till the expiry of the defect liability period.

We hereby agree to ratify all acts, deeds and things lawfully done by lead member, our said attorney pursuant to this power of attorney and that all acts deeds and things done by our aforesaid attorney shall and shall always be deemed to have been done by us/ Joint Venture.

Dated this the .....day of.....20...

Signature of the attorney  
Signature of the attorney is attested  
(by the authorised signatory of the company)

.....(Signature)

**Notes:**

- (i) To be executed by all the partners individually, in case of a Joint Venture.
- (ii) The mode of execution of the Power of Attorney should be in accordance with the procedure, if any, laid down by the applicable law and the charter documents of the executant(s) and when it is so required the same should be under common seal affixed in accordance with the required procedure.
- (iii) In case of incorporated companies, the common seal of the company has to be embossed on all pages.

.....  
(Name in Block letters of Executants) Seal  
of Company

Witness 1:

Witness 2:

Name:

Name:

Address:

Address:

Occupation:

Occupation:

**FORMAT FOR POWER OF ATTORNEY FOR AUTHORISED  
SIGNATORY OF JOINT VENTURE (JV) PARTNERS  
POWER OF ATTORNEY\***

(To be executed on non-judicial stamp paper of the appropriate value in accordance with relevant stamp Act. The stamp paper to be in the name of the company who is issuing the Power of Attorney.)

Know all men by thesepresent, we.....do hereby constitute, appoint and authorize Mr/Ms .....who is presently employed with us and holding the position of .....as our attorney, to do in our name and on our behalf, all such acts, deeds and things necessary in connection with or incidental to our bid for the work of including signing and submission of all documents and providing information/ responses to UP JAL NIGAM (URBAN) representing us in all matters, dealing UP JAL NIGAM (URBAN) in all matters in connection with our Tender for the said project.

We hereby agree to ratify all acts, deeds and things lawfully done by our said attorney pursuant to this Power of Attorney and that all acts, deeds and things done by our aforesaid attorney shall and shall alwaysbe deemed to have been done by us.

Dated this the .....day of.....20..

Signature of the attorney  
(Signature of the attorney is attested by the authorised signatory)

(Signature of authorized signatory of the company)

.....

(Signature and Name in Block letters of Signatory)Seal  
of Company

**Witness:**

Witness 1:

Name:

Address:

Occupation:

Witness 2:

Name:

Address:

Occupation:

**Notes:**

- (i) To be executed by all the partners individually, in case of a Joint Venture.
- (ii) The mode of execution of the Power of Attorney should be in accordance with the procedure, if any, laid down by the applicable law and the charter documents of the executant(s) and when it is so required the same should be under common seal affixed in accordance with the required procedure.
- (iii) In case of incorporated companies, the common seal of the company has to be embossed on all pages

**Form of Bid Security/Earnest Money Deposit****(Bank Guarantee Bond)**

Ref .....Date..... Bank Guarantee No:

In accordance with Notice Inviting Tender (NIT) No \_\_\_\_\_ Dated \_\_\_\_\_ for ..... invited by ..... U. P. Jal Nigam (Urban) .....[herein after referred to as the "Nigam" ] M/s \_\_\_\_\_ Address \_\_\_\_\_ [Hereinafter referred to as Tenderer (s)] wish /wishes to participate in the said tender and a Bank Guarantee for the sum of Rs. \_\_\_\_\_ [Rupees \_\_\_\_\_] valid for a period of 185 days (in words) is required to be submitted by the Tenderer towards the Bid Security/Earnest Money Deposit.

**AND WHEREAS** the Bank has accordingly at the request of the said Tenderer agreed to furnish this guarantee.

NOW THIS DEED WITNESSES AS FOLLOWS:

1. In consideration of Rs. .... (Rupees..... only)
2. The Bank shall pay to the Nigam on demand the sum under the clause above without demur and without requiring the Nigam to invoke any legal remedy that may be available to it, it being understood and agreed **FIRSTLY** that the Nigam shall be the sole judge of and as to whether the said Tenderer have committed breach, if any, of the terms and conditions of the said Tender and the extent of losses, damages, costs, charges and expenses caused to or suffered by or that may be caused to or suffered by the Nigam from time to time shall be final and binding on the Bank and **SECONDLY** that the right of the Nigam to recover from the Bank any amount under this Guarantee shall not be affected or suspended by reason of the fact that any dispute or disputes have been raised by the said Tenderer with regard to their liability or the proceedings are pending before any Tribunal, Arbitrator(s) or Court with regard thereto or in connection therewith, and **THIRDLY** that the Bank shall immediately pay the sum under clause to the Nigam on demand and it shall not be open to the Bank to know the reasons of or to investigate or to go into the merits of the demand or to question or to challenge the demand or to know any facts affecting the demand, and **LASTLY** that it shall not be open to the Bank to require proof of the liability of the said Tenderer to pay the amount before paying the sum demanded under clause above.
3. This guarantee is in addition to and not in substitution for any other guarantee executed by the Bank in favour of the Nigam on behalf of the said Tenderer.
4. The said Tenderer and the Nigam will be at liberty to vary and modify the terms and conditions of the said Tender without affecting this guarantee notice of which modification to the Bank hereby waived.
5. This guarantee shall not be affected by any change in the constitution of the bank or of the said Tenderer nor shall the guarantee be affected by any change in the constitution of the Nigam or by amalgamation or absorption with any other body corporate and this guarantee will be available to or enforceable by such body corporate.
6. The neglect or forbearance of the Nigam in enforcing any payments of moneys, the payment whereof is intended to be hereby secured or the giving of time by the Nigam for the payment thereof shall in no way, release the Bank from its liability under this deed.
7. This guarantee is irrevocable except with the written consent of the Nigam.

8. This guarantee shall come into force from the date hereof and shall remain valid till .....but if the period of the said Tender is, for any reason, extended and the Tenderer wishes to extend validity of his Tender, upon such extension if the said Tenderer fails to furnish or renew guarantee for the extended period, the Bank shall pay to the Nigam the said sum of Rs ..... or such lesser sum as the Nigam may demand.
9. Notwithstanding anything stated hereinbefore the liability of the Bank under the guarantee is restricted to Rs. .... (Rs ..... only). This guarantee shall remain in force upto unless a demand or claim under the guarantee is presented to the Bank in writing within Twelve (12) months from the date or expiry all rights of the Nigam under the guarantee shall be forfeited and the Bank shall be released and discharged from all liabilities hereunder.

IN WITNESS WHEREOF

.....day of .....

For.....

(Indicate the name of the Bank)

**Note:-**Such bank guarantee should be verifiable & enchashable from a branch located in the city where Divisional Office is situated.

**GENERAL INFORMATION**

(To be submitted by all the JV Partners individually)

All Agencies/firms applying for pre-qualification are requested to complete the information in this form. Nationality information to be provided for all owners or Bidders for partnerships or individually owned firms.

1	Name of firm.	
2	Principal Place of business-	
3	Correspondence Address:	
4	Office Telephone:	Mobile:
5	Fax:	E-mail:
6	Place of incorporation/registration: (Attach copy)	Date of incorporation: Registration valid up to:
7	Constitution or Legal status of bidder- a) An individual b) Proprietary firm c) Partnership firm d) Limited company or corporation Another (Pl. specify)	(Attach copy)
8	Power of Attorney of signatory of Bid	(Attach)

Name of the Directors / Partners	Position in the company	Nationality.
1		
2		
3		

Name of persons to be contacted and their contact details			
Name	Address	Phone No. / Mobile	E-mail

Signature of Bidder.

**(EARNEST MONEY)**

I/ We deposit herewith an Earnest Money for (Rs. in words)..... in the following form as per **Clause 3.9.2** of Instruction to Bidders.

I/We also agree to deposit requisite performance security/ additional performance security/ securitydeposit as per conditions of this tender document.

The details of deposit of Earnest Money are given below:

<b>Sl. No.</b>	<b>Description</b>	<b>Amount Rs.</b>	<b>Period of Validity</b>	<b>BG No. and Name of Issuing Bank</b>	<b>Remarks</b>

DATE

SIGNATURE & SEAL

ADDRESS

NAME

**AFFIDAVIT OF BID VALIDITY**

**IMPORTANT: -**

- 1- This affidavit is to be furnished positively at the time of submitting the tender.
- 2- The affidavit is to be typed on stamp paper worth Rs. 100/- duly signed and notarized, affixing a revenue stamp of Rs. 2/- only and the expenditure incurred shall be borne by the tenderer.

**AFFIDAVIT FORM**

Tender invited by .....

Tender for ..... Tender

Notice No.& Date ..... Name of Tenderer

.....

..... IN  
 CONSIDERATION of the U.P. JAL NIGAM (URBAN) having treated the bidder to be an eligible person, whose tender may be considered, the bidder hereby agrees to the conditions that the proposal in response to the above invitation shall not be withdrawn within 120 (One hundred and twenty) days from the date of opening the tender, also to the condition that if, the bidder does withdraw his proposal within the said period, the earnest money deposited by him may be forfeited by the U.P. JAL NIGAM (URBAN) and I/we may, in addition to other actions detailed in bid document, be debarred from tendering for a period of one year reckoned from the date of opening of the tender, as per discretion of the later.

Signed this.....day of ..... 20...

Signed by: -

(BIDDER)  
Signature & Seal

Witness: -

- 1.....
- 2.....

**शपथ-पत्र (STANDARD AFFIDAVIT)**

(पार्टनरशिप फर्म की दशा में प्रत्येक पार्टनर द्वारा भरा जायेगा)

मैं ..... पुत्र श्री .....  
निवासी .....  
(स्थायी पता) .....  
(अस्थायी पता) ..... का निवासी हूँ।

राजपत्रित अधिकारी  
द्वारा प्रामाणित  
पासपोर्ट साईज  
नवीनतम फोटोग्राफ  
चस्पा किया जाय।

मैं शपथ पूर्वक निम्न घोषणा करता हूँ: -

- मेरे पास पर्याप्त चल और अचल सम्पत्ति है और व्यवसायिक रूप से मैं इस निविदा द्वारा आमंत्रित कार्यों को पूरा करने के लिए सक्षम और समर्थ हूँ। मेरे पास आवश्यक मशीनें और उपकरण आदि भी हैं तथा मुझे इस कार्य का पर्याप्त अनुभव है।
- उ.प्र.जल निगम(नगरीय ) द्वारा "Survey, Soil Investigation, Design, Supply of all materials, labour, T&P etc. Required for Construction/Repairing , Erection, Testing And Commissioning of Water Supply Works Such RCC Over Head Tank, Pump house, Staff quarter, Boundary wall, Gate, Site development, renovation of Existing facilities including laying & jointing of rising main/Distribution System, providing Functional Water supply house Connections , construction of tube wells including SCADA automation and other appurtenant works of "Re-Organization of Nagar Panchayat Mau Aima Water Supply Scheme District-Prayagraj under AMRUT 2.0 Programme" on Turnkey basis as specified in Tender Document. The scope of works also includes trial and run of 3 month and defect liability period of 12 months for civil works and 24 months for E&M works after completion of successful trial and run. All completed and commissioned works of above scheme shall be handed over to Nagar Panchayat Mau Aima ,District - Prayagraj after 3 months of successful trial run period." हेतु निविदा निर्गत की गयी है, उसके लिये मैं विभाग द्वारा निर्धारित प्रारूप पर निविदा भर रहा हूँ।
- मेरे द्वारा निविदा में डाली गयी दरों को निविदा खुलने की तिथि से 120 (एक सौ बीस) दिनों तक वैध रखा जायेगा ।
- मेरे द्वारा दिये जा रहे विभिन्न प्रमाण पत्र जैसे चरित्र प्रमाणपत्र, आयकर प्रमाण पत्र, जी.एस.टी. प्रमाणपत्र, बिड सिक्योरिटी प्रमाण पत्र, सॉल्वेन्सी प्रमाणपत्र, बिडकैपिसिटी प्रमाणपत्र, अनुभव प्रमाणपत्र, टर्नओवर प्रमाणपत्र (अर्थात Format-IISIX) आदि तथा अन्य सुसंगत अभिलेख आदि अपेक्षित रूप में निविदाप्रपत्र के साथ अपलोड कर दिये गये हैं, जिनकी सत्यता प्रामाणित की जाती है।
- मेरे विरुद्ध अपराधिक मुकदमों का विवरण निम्न प्रकार है । यहां पूरा विवरण दिया जाये।
  - मुकदमा नम्बर .....
  - धारायें .....
  - थाना .....
  - जनपद .....
- न्यायालय (जहां मुकदमाचल रहा है) .....
- मैं उ.प्र. जल निगम (नगरीय) अथवा राज्य सरकार के अन्य विभागों द्वारा ब्लैक लिस्टेड ठेकेदार की श्रेणी में नहीं आता हूँ न ही मुझे किसी विभाग द्वारा डिबार किया गया है। मैं अपराधिक गतिविधियों, माफिया तथा गैंगेस्टर गतिविधियों और संगठित अपराध करने की गतिविधियों और असमाजिक कार्यों आदि में लिप्त नहीं हूँ। मैं माफिया और अपराधी नहीं हूँ। मेरा चाल-चलन, कार्य तथा आचरण उत्तम है।
- मेरे विरुद्ध जनपद में तथा प्रदेश में कोई भी मुकदमादर्ज नहीं है।
- यदि ठेका प्राप्त करने के पश्चात मेरे विरुद्ध माफिया गतिविधियों/असामाजिक गतिविधियों व संगठित अपराधिक गतिविधियों में लिप्त होने के बारे में कोई शिकायत प्रमाणित पायी जाती है, अथवा मेरे द्वारा तकनीकी एवं वित्तीय क्षमता के सम्बन्ध में प्रस्तुत विवरण / प्रमाणपत्र असत्य पाया जाता है, तो सक्षम अधिकारी को यह अधिकार होगा कि वह मेरा ठेका/अनुबंध निरस्त कर दें तथा अनुबंध के अन्तर्गत अन्य सुसंगत कार्यवाही करें। इस पर मुझे कोई आपत्ति नहीं होगी।
- मेरे द्वारा यदि विभाग/राज्य सरकार के विरुद्ध कोई अपराधिक कार्य किया जाता है अथवा सरकारी धन का गबन किया जाता है, तो सक्षम अधिकारी को यह अधिकार होगा कि वह मेरे विरुद्ध अपराधिक मुकदमा सुसंगत धाराओं/ नियमों के अन्तर्गत दर्ज कर दें।

11. मैं अनुबंध की शर्तों के अनुसार समय से पूरी गुणवत्ता के साथ तथा निर्धारित विशिष्टियों के अनुरूप कार्यपूरा करूंगा और विभाग को पूरा सहयोग प्रदान करूंगा।
  12. मेरा कार्य एवं आचरण उत्तम हैं।
  13. मैं शपथपूर्वक घोषणा करता हूँ कि मेरा स्थाई पता और अस्थायी पता निम्नप्रकार है—  
 (अ) स्थाई पता (दूरभाष सहित) .....
  - .....  
 (ब) अस्थायी पता (दूरभाष सहित).....  
 .....
- (यहां पूरा पता दूरभाष सहित एवं पिन कोड सहित लिखा जाये)
14. मैं शपथपूर्वक घोषणा करता हूँ कि उपरोक्त पते पर रहता हूँ तथा विभाग द्वारा प्रदान किये गये कार्य के पूरा होने तक मेरे किसी पते में सामान्यतः कोई परिवर्तन नहीं होगा यदि अपरिहार्य परिस्थितियों में किसी पते में परिवर्तन आता है तो इसकी सूचना मैं तत्काल संबंधित प्राधिकृत अधिकारी, और जिला मजिस्ट्रेट/ कलेक्टर को दूंगा।
  15. मेरा पैन नं० ..... है। (आयकर विभाग द्वारा प्रदत्त प्रमाणपत्र संलग्न किया जाये)
  16. मेरा आधार संख्या (प्रोपराईटर/ पार्टनरशिप फर्मों हेतु).....(आधारकार्ड की स्व सत्यापित प्रति संलग्न की जाय)
  17. मेरा जी.एस.टी. पंजीयन संख्या ..... है। (पंजीयन प्रमाणपत्र की स्व सत्यापित प्रति संलग्न की जाय)
  18. मैं अपनी पूर्ण जानकारी में पूरे होशोहवाश में स्वस्थचित्त से पूरी सत्य निष्ठा से तथा स्वेच्छा से यह शपथ-पत्र लिख कर दे रहा हूँ। ईश्वर मेरी मदद करें।

दिनांक :

शपथी का पूरा हस्ताक्षर

पूरा नाम—  
पता—

**नोट—**

- 1- यह स्वघोषणा शपथपत्र रू० 100/- (रू० एक सौ) के स्टाम्प पेपर पर नोटरी द्वारा सत्यापित कराते हुए दिया जायेगा, **तथा शपथपत्र के समस्त बिन्दुओं को समाहित किया जायेगा, अन्यथा निविदा अस्वीकार की जा सकती है।**
- 2- असत्य शपथ-पत्र देना एक संगीन और संज्ञेय अपराध है।
- 3- संबंधित व्यक्ति द्वारा पासपोर्ट साइज का अपना रंगीन फोटोग्राफ, जो राजपत्रित अधिकारी/नोटरी द्वारा प्रमाणित हो, शपथ-पत्र के ऊपर निर्धारित स्थान पर चस्पा किया जायेगा।
- 4- Bidders from out side the State may translate the above format in English and submit the notarised affidavit, however the contents should remain the same.

**FINANCIAL INFORMATION**

(To be submitted by all the JV Partners individually)

Details to be furnished duly supported by Audited Balance sheets/profit & loss account for the immediate past 5 (Five) consecutive financial years duly certified by the **Statutory Auditor** of the firm as submitted by the Bidder to the Income Tax

**BANKER**

Name of Banker-	
Address of Banker-	
Telephone	Contact name & Title
Fax	Email-

Sl. No.	Particulars	Financial Year				
		-----	.....	.....	.....	.....
1	Gross Annual Turnover on Construction works					
2	Profit/Loss					
3	Share Capital/Fixed Assets					
4	Net Worth					
5	Current liabilities: a) Book Cash credit b) Other sundry creditors					
6	Solvency					

**Note-**

- (1) The information provided above shall be certified by the Statutory Auditor of Firm and supported by copies of tax returns.
- (2) Permanent Account Number (IT):
- (3) Goods & Service Tax Registration Number.
- (4) Acknowledgement of Income Tax return: for the last 3 years. **(Enclose copies for the Last Three Years)**

**Signature of Statutory Auditor with Seal.****Signature of Bidder**

**SAMPLE FORM (II-B)**

**SAMPLE FORMAT FOR SOLVENCY CERTIFICATE ON THE  
LETTER HEAD OF BANK**

No. ....

Dated: .....

**(On Letter Head of Bank)**

This is to certify that M/s /Sri ..... address  
..... a customer of our bank is/are respectable.

To the best of our knowledge and information he/they is/are are solvent to the extent of Rs.  
..... (Rupees .....). This certificate is issued without any  
responsibility on the Bank or any of the officers.

(Signature)

of the Bank Authority

Date:

Name of Bank & Seal

**Note:**

1. Solvency Certificate should be issued only by a scheduled commercial bank.
2. In case of partnership firm, certificate should include names of all partners as recorded with the Bank.
3. Solvency Certificates should be signed, dated, and stamped by an authorized signatory of the Bank; else they shall be summarily rejected.

**FORM-III**

(To be submitted by all the JV Partners individually)

**DETAILS OF SIMILAR TYPE OF WORKS COMPLETED (In the same name and style)  
DURING LAST 10 YEARS (as on the date of publication of NIT)**

(Supported with Form-IIIA)

Sl. No.	Name of Work	Brief Scope of Work	Name of client U.P. Jal Nigam / Employer	Contract Value (Rs. in Lacs)	Scheduled dates of		Actual Date of completion	If executed as JV, state % age share in JV	Litigation/ Arbitration cases pending	Penalties /Liquidated damages imposed, if any	Reasons of delay, if any
					Start of work	Completion of work					

**Note:** The attested photocopy of the experience certificate of the Engineer-in-charge not below the rank of Executive Engineer/Project Manager or equivalent be appended with the detail. In the absence of these documents, the work would not be considered for eligibility criteria.

Dated signature of Bidder with stamp

**SAMPLE FORM-III A**

(To be submitted by all JV Partners)

**DETAILS OF CONTRACTS OF SIMILAR NATURE AND COMPLEXITY****Name of Applicant : .....**

Use a separate sheet for each contract-

<b>1</b>	Number of contract:	
<b>2</b>	Name of work:	
<b>3</b>	Country:	
<b>4</b>	Name, address and contact number of employer:	
<b>5</b>	Employer address & phone nos.:	
<b>6</b>	Nature of works and special features relevant to the contract for which the Applicant wishes to prequalify:	
<b>7</b>	Value in specified currencies at completion, or at date of award for current contracts: • Total Contract Amount : Rs .....(Rs in words )	
<b>8</b>	Date of award:	
<b>9</b>	Scheduled Date of completion:	
<b>10</b>	Contract duration (years and months):	
<b>11</b>	Actual Date of Completion:	
<b>12</b>	Penalties/Liquidated Damages imposed if any:	
<b>13</b>	Arbitration awarded/ pending if any: (Provide Details)	

Signature &amp; Seal of Applicant/Bidder

**INFORMATION ABOUT WORKS UNDER PROGRESS/BIDS SUBMITTED**

(To be submitted by all the JV Partners individually)

**(A) DETAILS OF WORKS WHICH ARE IN PROGRESS/ AWARDED AS ON THE DATE OF SUBMITTING THIS APPLICATION**

Sl No.	Name of work /Place and State	Brief Scope of work	Contract No. and Date	Share Holding in JV (if awarded to JV)	Name and Address of Employer	Value of Contract (Rs. in Lacs)	Stipulated date of start & completion	Up to date Physical progress in %age	Value of works remaining to be completed (Rs. in Lacs)	Anticipate date of completion with reasons of delay, if any.

**(B) WORKS FOR WHICH BIDS ALREADY SUBMITTED AS ON THE DATE OF SUBMITTING THIS APPLICATION**

Sl No.	Description of works	Place & State	Name and Address of Employer	Share Holding in JV (if submitted as JV)	Estimated value of works (Rs. in Lacs)	Stipulated date of Completion	Date when decision is expected	Remarks, if any

Certified that all works (with any organization and of all categories/types) which have either been awarded to us or are in progress or for which bids have been submitted on the date of bid submission have been included in the details given above and no work has been left out.

**Signature of Bidder**

**SAMPLE FORM – V.**

**DETAILS OF TECHNICAL & ADMINISTRATIVE PERSONNEL TO BE EMPLOYED FOR  
THE WORKS**

(NIT issuing authority should amend as per requirement of bid)

<b>S. No.</b>	<b>Designation</b>	<b>Total number</b>	<b>Number available for this work</b>	<b>Name</b>	<b>Qualification</b>	<b>Date of Birth</b>	<b>Experience in Yrs.</b>	<b>Remarks</b>
<b>1</b>	<b>2</b>	<b>3</b>	<b>4</b>	<b>5</b>	<b>6</b>	<b>7</b>	<b>8</b>	<b>9</b>
1	Graduate Eng. Civil							
2	Diploma Eng. Civil							
3	Diploma Eng. Electrical							
4	Work Supervisor							
5	Others, specify							

**UNDERTAKING:**

1. I/we further understand that the decision of Executive Engineer regarding presence/absence of my/our Engineer from the work shall be final and binding upon us.

Signature of Bidder

**EXPERIENCE OF WORKS**

(**Attention:** This certificate shall only be accepted when all the contracted works have been successfully completed and commissioned)

**Name of work & location:**

Details about works executed:

Estimated cost: (Rs. Lacs) .....

Contract No.:

Contract Value:

Final Contract Value: (Rs. Lacs) .....

Date of start: .....

**Dates of completion:**

(i) Scheduled date of completion: .....

(ii) Actual date of completion: .....

Amount of compensation levied for delayed completion, if any: - .....

(if levy of compensation not yet decided, it may be mentioned accordingly)

Performance Report:                      Very Good/Good/Fair/Poor

Dated:                                      Executive Engineer/ Project Manager or Equivalent

(Seal)

**Note:** - The performance certificate should be clear & exhaustive enough to establish similarity with the work under Bid otherwise such experience certificate shall be ignored for evaluation purpose.

**SAMPLE FORM-(VII)**

**DETAILS OF CONSTRUCTION PLANT AND EQUIPMENT (LIKELY TO BE USED IN  
CARRYING OUT THE WORK) AVAILABLE WITH THE CONTRACTOR:**

(NIT issuing authority should amend as per requirement of bid)

S. No	Name of Equipment	Nos.	Capacity	Age /Condition	Owned /Leased	Remarks
1	2	3	4	5	6	7
<b>(a)</b>	<b>Machineries for Earth work.</b>					
1.	Excavators /loaders (Min. 0.3 cum Bucket Capacity)					
2.	Trolley/Tractor (1.5 cum capacity)					
<b>(b)</b>	<b>Machinery for structural concrete and Concrete lining.</b>					
1.	Transit Mixers/Agitator cars of 4 cum capacity.					
2.	Vibrators (Needle and plate)					
3.	Power generating units of adequate capacity					
4.	Diesel Pump Set of 5HP. for dewatering					
<b>(c)</b>	<b>Equipment for field testing</b>					
	<b>Compression testing machine</b>					
1.	Concrete cube moulds 150 x 150 x 150mm					
2.	Slump cones					
3.	Graduated glass cylinder					
4.	Set of sieves for fine aggregate (4.75, 2.36, 1.18 mm & 600, 300, 150 micron)					
5.	Weighing scale (Pan Type) with weights					
6.	Auto level					
7.	Measuring Tape 30m/3m					

**UNDERTAKING:**

1. I/we undertake that above machineries and centering & shuttering material will remain in Good working condition and in useable form throughout the currency of work.
2. I/we further undertake, that if, there is any reduction in the equipment, below the limit required for pre-qualification, I/we will inform competent authority to whom application for pre-qualification is being made, within 3 days of its occurrence and arrange to make it up within another one week, failing which, U.P. Jal Nigam will be free to impose any penalty that it may deem fit, which will be final and binding upon me/us.

**Signature of Bidder (s)**

(TO BE SUBMITTED BY ALL THE JV PARTNERS INDIVIDUALLY)  
**LITIGATION HISTORY**

Name of Bidder or Partner of a Firm/JV:
---

Date of Award or filing (if in process)	Name of client, cause of litigation, and matter in dispute and name of claimant party	Contract value (Rs. In Lacs)	Disputed amount (Rs. In Lacs)	Actual awarded amount (Rs. In Lacs)	Award For or against Bidder

**Bidders including their partners/directors** shall provide information on the history of the pending vigilance/criminal investigations, litigation or arbitration resulting from contracts executed or under execution during the last five (5) years.

Providing any false or misleading information, or hiding any information, may result in disqualification of the Bidder.

*In addition, each of the bidder/ partners of the bidder shall certify that they are not debarred from tendering nor blacklisted/removed from the list of enlisted contractors by U.P. Jal Nigam (Urban) / CPWD/PWD/MES/ OR any Government authority.*

Signature of Bidder

**LETTER COMPRISING BID**

To,

U.P. Jal Nigam (Urban), (U.P.)

Sir,

**Name of Work:** -.....

1. Having examined the Press Note, Notice Inviting Tenders and bid document I/ We offer to execute the works described above and remedy any defects therein in conformity with the Conditions of Contract, specifications, drawings, Bill of Quantities and Addenda for percentage rate below/ percentage above/ at par as in the financial bid, as referred to in relevant clauses of Instructions to Bidder.
2. I/We confirm that our bid is according to the term & conditions and specifications laid down in the bid documents. I/we have furnished all information and details necessary for eligibility and have no further pertinent information to supply.
3. I/we also authorize employer or his representative to approach individuals, employers, firms, and corporations to verify our competence and general reputation.
4. I/We undertake to commence the works on receiving the Notice to Proceed with work in accordance with the contract documents.
5. I/We agree to keep the offer in this tender valid for a period of 120 (One hundred and twenty) days as mentioned in the bid documents and not to modify the whole or any part of it for any reason within the above period. If the tender is withdrawn by me/us for any reason what so ever, the EarnestMoney deposited by me/us will be forfeited by the U. P. Jal Nigam (Urban)and other actions in accordance with bid documents may be taken against me.
6. Further, I/We agree that in case of forfeiture of Earnest Money or Performance Guarantee as aforesaid, I/We shall be debarred for participation in the re-tendering process of the work.
7. I/we hereby distinctly and expressly declare and acknowledge that before the submission of my/our tender I/we have carefully followed the instruction in the tender documents and that I/we have made such examination of the contract documents and of the plans, specifications and quantity, and of the location where the said work is to be done, and such investigation of the work required to be done and in regard to the materials required to be furnished as to enable me/us thoroughly understand the intention of the same and the requirements, covenants, agreements, stipulations and restrictions contained in the contract and in the said plans and specifications and distinctly agree that I/we will not hereafter make any claim or demand upon U.P. Jal Nigam based upon or arising out of any alleged misunderstanding or misconception, mistake on my/our part of the said requirements, stipulations, restrictions and conditions.
8. I understand that quantities given in Bill of Quantities in **Schedule 'G'** are liable to change up to any extent. I will not demand any compensation/cost on this account.
9. I/we have deposited and uploaded proof of EMD deposit for the work.
10. If my/our tender is not accepted, this sum shall be returned to me/us latest within 30th day of award of contract. If my/our tender is accepted, the earnest money shall be returned to me/us on my/our entering into contract agreement duly furnishing performance/additional performance security deposit. If upon intimation being given to me/us by the U. P. Jal Nigam (Urban)of performance security/additional performance security deposit defined in Tender Document, I/we fail to deposit the same, then I/we agree to the forfeiture of the earnest money.
11. I/We undertake and confirm that eligible similar work(s) has/have not been got executed through another contractor on back-to-back basis. Further that, if such a violation comes to the notice of U.P. Jal Nigam, then I/We shall be debarred for tendering in future forever. Also, if such a violation comes to the notice of U.P. Jal Nigam before date of start of work, the Engineer shall be free to forfeit the entire amount of Earnest Money Deposit/Performance Guarantee/Additional Performance Guarantee.

12. Any notice required to be served on me/us if delivered to me/us personally or forwarded by post to me/us (registered) or left at my/our address given herein, such notice shall if sent by post, be deemed to have been served on me/us at the time when in due course of post, it would be delivered at the address to which is sent.
13. I/we fully understand that the written agreement (to be entered into between me/us and the U. P. Jal Nigam(Urban) shall be the foundation of the rights of both the parties and contract shall not be deemed to be complete until agreement has first been signed by me/us and then by the proper officer authorized to enter into contract on behalf of the U. P. Jal Nigam(Urban).
14. I/we understand that you are not bound to accept the lowest or any bid you receive.
15. I/We undertake that neither of our partners/directors have been banned by U.P. Jal Nigam (Urban) / CPWD/PWD/MES/ OR any Govt. organisation. I/We further declare that no investigating authority has instituted any vigilance enquiry nor there are criminal proceedings against any of our partners/directors in any Court of law during the last 5 years from the last date of bid submission.

**Encl: As above**

Address with phone No.

Signature of Contractor/Tenderer  
Name-

Dated the ..... day of ..... 20....

Signature of Witnesses:

Name and address :

## **SECTION – 4**

### **PART-I**

- **CONDITIONS OF CONTRACT**
- **CLAUSES OF CONTRACT**

## CONDITIONS OF CONTRACT

### **Definitions-**

1. **The contract** means the document forming the tender and acceptances thereof and the formal agreement executed between the competent authority on behalf of the Chairman, U P Jal Nigam (Urban) and the Contractor, together with the documents referred to therein including these conditions, the specifications, designs, drawings and instructions issued from time to time from one contract and shall be complementary to one another.
2. In the contract, the following expressions shall, unless the context otherwise requires have the meanings, hereby respectively assigned to them:-
  - i. **The expression works or work** shall, unless there be something either in the subject or context repugnant to such construction, be construed and taken to mean the works by or by virtue of the contract contracted to be executed whether temporary or permanent, and whether original, altered, substituted or additional.
  - ii. **The site** shall mean the land/or other places on, into or through which work is to be executed under the contract or any adjacent land, path or street through which work is to be executed under the contract or any adjacent land, path or street which may be allotted or used for the purpose of carrying out the contract.
  - iii. **The Contractor** shall mean the individual, firm or company, whether incorporate or not, Joint Venture undertaking the works and shall include the legal personal representative of such individual or the persons composing such firm or company, or the successors of such firm or company and the permitted assignees of such individual, firm of company.
  - iv. **The Engineer-in-Charge** means the Engineer/ officer who shall supervise and be in-charge of the work and who shall sign the contract on behalf of the Chairman, U P Jal Nigam(Urban) as mentioned in **Schedule F** hereunder.
  - v. **Excepted Risk** are risks due to riots (other than those on account of contractor employees), war (whether declared or not) invasion, act of foreign enemies, hostilities, civil war, rebellion revolution, insurrection, any act of Government, damages from aircraft, acts of God, such as earthquake, lightening and unprecedented floods, and other causes over which the contractor has no control and accepted as such by the Accepting Authority. Provided that the contractor is also to show that he has taken all due precautions to avoid /minimize any adverse effect / damage from the above or causes solely due to use or occupation by Government of the part of the works in respect of which a certificate of completion has been issued.
  - vi. **Bill of quantity** means the price and completed Bill of Quantities form forming part of the Bid as per **Schedule "G"**
  - vii. The **Defect Liability Certificate** is the certificate issued by Engineer-in-Charge after defect liability period has ended and upon correction of defects by the contractor.
  - viii. The **Defect Liability Period** means a fixed period of time during which the contractor has an express contractual right to return to the site to rectify defects. **It will be 12 (Twelve) months for Civil Works and 24 (Twenty Four) months for E/M works.** The Defect Liability Period

will be reckoned after successful completion of work, its commissioning, completion of trial run for a period as specified and handing over of entire work to the authority designated by Engineer-in-Charge, in writing.

- ix. **The intended completion date** is the time intended to complete the work by the contractor.
- x. **The start date is as given to the contractor after execution of contract.** It is the date when the contractor shall commence execution of the works.
- xi. **A sub contractor** is a person or corporate body who after due permission of Employer has a contract with the contractor to carry out a part of the construction work in the contract, which includes work on the site.
- xii. **Temporary works** are works designed, constructed, installed and removed by the contractor that are needed for construction or installation of the works.
- xiii. **Market Rate** shall be the rate as decided by the competent authority on the basis of the cost of materials and labour at the site where the work is to be executed plus the percentage mentioned in **Schedule F** to cover, all overheads and profits.
- xiv. **Schedule(s)** referred to in these conditions shall mean the relevant schedule(s) annexed to the tender papers, with the amendments thereto issued up to date of receipt of the tender.
- xv. **U.P. Jal Nigam (Urban)** means Uttar Pradesh Jal Nigam (Urban) which invites tenders on behalf of Government of Uttar Pradesh.
- xvi. **Specifications** means the specifications followed by UPJN/ UPPWD/CPWD/BIS.
- xvii. **Tender value** means the value of the entire work as stipulated in the letter of award.

**Scope and Performance:**

- 3. Where the context so requires, words imparting the singular only also include the plural and vice versa. Any reference to masculine gender shall whenever required include feminine gender and vice versa.
- 4. Heading and Marginal notes to these General Conditions of Contract shall not be deemed to form part thereof or be taken into consideration in the interpretation or construction thereof or of the contract.
- 5. The contractor shall be furnished, free of cost one certified copy of the contract documents except standard specifications, Schedule of Rates and such other printed and published documents, together with all drawings as may be forming part of the tender papers. None of these documents shall be used for any purpose other than that of this contract.

**Works to be carried out:**

- 6. The work to be carried out under the Contract shall, except as otherwise provided under these conditions, all labour, materials, tools, plants, equipment and transport which may be required in preparation of and for and in the full and entire execution and completion of the works. The descriptions given in the Bill of Quantities (**Schedule-G**) shall unless otherwise stated, be held to include wastage on materials, carriage and cartage, carrying and return of empties, hoisting, setting, fitting and fixing in position and all other laborer necessary in and for the full and entire execution and completion of the work as aforesaid in accordance with good practice and recognized principles.

**Sufficiency of Tender:**

7. The contractor shall be deemed to have satisfied himself before tendering as to the correctness and sufficiency of his tender for the works and of the rates and prices quoted in the **Schedule G**, which rates and prices shall, except as otherwise provided, cover all his obligations under the Contract and all matters and things necessary for the proper completion and maintenance of the works.

**Discrepancies and adjustment of Errors:**

8. The several documents forming the contract are to be taken as mutually explanatory of one another, detailed drawings being followed in preference to small scale drawing and figured dimensions in preference to scale and special conditions in preference to General Conditions.
- 8.1. In the case of discrepancy between the Bill of Quantities, the Specifications and/or the Drawings, the following order of preference shall be observed: -
- a. Description of Bill of Quantities.
  - b. Particular Specification and Special Condition, if any
  - c. Drawings.
  - d. UPJN/UPPWD/ CPHEEO specification.
  - e. Indian Standard Specifications of B.I.S.
- 8.2. If there are varying or conflicting provisions made in any one document forming part of the contract, the Accepting Authority shall be the deciding authority with regard to the intention of the document and his decision shall be final and binding on the contractor.
- 8.3. Any error in description, quantity or rate in Schedule of Quantities/Bill of Quantities of any omission there from shall not vitiate the Contract or release the Contractor from the execution of the whole or any part of the works comprised therein according to drawings and specifications or from any of his obligations under the contract.

**Signing of Contract:**

9. The successful tenderer /contractor, after submitting the performance guarantee within a period mentioned in letter of acceptance shall attend the office of the Engineer-in-Charge for authentication signing and completion of the contract document and execute the agreement consisting of:-
- i. Drawings.
  - ii. The notice inviting tender, all the documents including drawings, if any, forming the tender as issued at the time of invitation of tender and acceptance thereof together with any correspondence leading thereto.
  - iii. Standard Forms along with relevant annexure.
- 10 All the documents as specified in the technical bid/eligibility bid document should be uploaded within the period of bid submission. U.P. Jal Nigam(Urban)will not be liable for incomplete/inaccurate/non-submission of bid for any reason whatsoever including technical reasons. It is made clear that separate submission of originals of any documents (except Bank Guarantee/FDR) other than scanning and uploading them, are not required, unless called for, after opening of financial bid.
- 11 The bid submission shall become invalid if:

- (i) The bidder is found ineligible.
- (ii) The bidder does not upload all the documents as stipulated in the bid document.
- (iii) If any discrepancy is noticed between uploaded documents and originals/hard copies submitted later.
- (iv) If subsequent to due date of submission of bid and/or after its submission bidder makes any further communication/ representation with regard to the bid (whether technical or financial) than otherwise called for by the undersigned as a clarification.
- (v) If a bidder does not quote any percentage above/below/par on the total amount of the tender or any section/sub head in percentage rate tender. Further the tender will not be considered as lowest bid. Conditional tenders or Tenders without e-tender document fee & earnest money or invalid earnest money shall be summarily rejected.

## CLAUSES OF CONTRACT

<p><b>Performance Guarantee/ Security Deposit</b></p>	<p><b>CLAUSE1</b></p> <p>(i) Performance guarantee @10% of the contract cost will have to be submitted at the time of signing the contract in the form of FDR/ Bank Guarantee from any scheduled commercial Bank. Alternatively on request of the contractor/firm, 5% of the performance Guarantee will be accepted at the time of signing of contract and rest 5% may be deducted from the initial running bill in a single deduction or at the rate of minimum 10% of the gross bill amount of running bill. However, in any case whole amount of balance performance guarantee shall be deducted within one year.</p> <p>(ii) This period can be further extended by the Engineer-in-Charge up to a maximum period as specified in Schedule „F“ on written request of the contractor stating the reason for delays in procuring the Performance Guarantee, to the satisfaction of the Engineer-in-Charge. This guarantee shall be in accordance with the form annexed hereto (Annexure-7). Such bank guarantee should be verifiable &amp; enchashable from a branch located in the city where Divisional Office is situated. In case a fixed deposit receipt of a scheduled commercial Bank is furnished by the contractor to U.P. Jal Nigam as part of the performance guarantee and the Bank is unable to make payment against the said fixed deposit receipt, the loss caused thereby shall fall on the contractor and the contractor shall forthwith on demand furnish additional security to U.P. Jal Nigam to make good the deficit.</p> <p>(iv) <b>The Performance Guarantee/Security Deposit shall be initially valid up to the stipulated date of completion plus 60 days</b> beyond that. In case the time for completion of work gets enlarged, the contractor shall get the validity of Performance Guarantee extended to cover such enlarged time for completion of work. This guarantee shall thereafter be continued to be validated upto 60 days beyond the end of defect liability period. After end of the defect liability period as certified by the competent authority the performance guarantee / <b>security deposit</b> shall be returned to the contractor, without any interest.</p> <p>(v) The Engineer-in-Charge shall not make a claim under the performance guarantee/Security except for amounts to which U.P. Jal Nigam is entitled under the contract (not withstanding and/or without prejudice to any other provisions in the contract agreement) in the event of:</p>
---	---

	<ul style="list-style-type: none"> <li>a. Failure by the contractor to extend the validity of the Performance Guarantee as described herein above, in which event the Engineer-in-Charge may claim the full amount of the Performance Guarantee.</li> <li>b. Failure by the contractor to pay U.P. Jal Nigam any amount due, either as agreed by the contractor or determined under any of the Clauses/Conditions of the agreement, within 30 days of the service of notice to this effect by Engineer-in-Charge.</li> <li>c. Failure by the contractor to rectify any defects as defined in the <b>defect liability clause in the Schedule F</b> of contract data to the satisfaction of the Engineer-in-Charge.</li> </ul> <p>(vi) In the event of the contract being determined or rescinded under provision of any of the Clause/Condition of the agreement, the performance guarantee shall stand forfeited in full and shall be absolutely at the disposal of U.P. Jal Nigam.</p> <p>(vii) <b>Additional Performance Guarantee:</b> Works for which the cost of the tender received is more than 10 % below the estimated cost of works, in such situation, the performance security for first 10% below shall be 10% thereafter, additional performance security @ 0.50 % for each 1% further below than 10 % shall be deposited by the firm in order to safeguard against contractor leaving the works.</p>
<p><b>Recovery of Security Deposit</b></p>	<p><b>CLAUSE 1 A</b></p> <p>The person/persons whose tender(s) may be accepted (hereinafter called the contractor) shall permit U.P. Jal Nigam (Urban) at the time of making any payment to him for work done under the contract to deduct a sum of 5% of contract value at the rate of 10% of the gross amount in a manner described in Clause-1. Such deductions will be made and held by U.P. Jal Nigam by way of Security Deposit unless he/they has/have deposited the amount of Security at the rate mentioned above in the form of pledged fixed deposit receipts issued by any scheduled commercial bank. In case a fixed deposit receipt is furnished by the contractor to U.P. Jal Nigam (Urban) as part of the security deposit and the Bank is unable to make payment against the said fixed deposit receipt, the loss caused thereby shall fall on the contractor and the contractor shall forthwith on demand furnish additional security to U.P. Jal Nigam (Urban) to make good the deficit.</p> <p>All compensations or the other sums of money payable by the contractor under the terms of this contract may be deducted from, or paid by the sale of a sufficient part of his security deposit or from the interest arising therefrom, or from any sums which may be due to or may become due to the contractor by U.P. Jal Nigam (Urban) on any account whatsoever and in the event of his Security Deposit being reduced by reason of any such deductions or sale as aforesaid, the contractor shall within 10 days make good in pledged fixed deposit receipt tendered by any scheduled commercial bank, or any sum or sums which may have been deducted from, or raised by sale of his security deposit or any part thereof. The security deposit shall be collected from the running bills and the final bill of the contractor at the rates mentioned above.</p> <p>The security deposit as deducted above can also be released against bank guarantee issued by a scheduled commercial bank on its accumulations to a minimum of Rs. 5.00 lacs subject to the condition that amount of such bank guarantee, except last one, shall not be less than Rs. 5.00 lacs. Provided further that the validity of bank guarantee including the one given against the earnest money shall be in conformity with provisions contained in Clause 17 which shall be extended from time to time depending upon extension of contract</p>

	<p>granted under provisions of Clause 2 and Clause 5. Such bank guarantee should be verifiable &amp; enchashable from a branch situated in the city where Divisional Office is situated</p>
<p><b>Compensation for Delay</b></p>	<p><b>CLAUSE 2</b></p> <p>If the contractor fails to maintain the required progress in terms of clause 5 or to complete the work and clear the site on or before the contract or justified extended date of completion, as per clause 5 (excluding any extension under Clause 5.5) as well as any extension granted under clauses 12 and 15, he shall, without prejudice to any other right or remedy available under the law to U.P. Jal Nigam on account of such breach, pay as agreed compensation the amount calculated at the rates stipulated below as the authority specified in <b>Schedule „F“</b> may decide (whose decision in writing shall be final and binding) on the amount of Tendered Value of the work for every completed day/month (as determined) that the progress remains below that specified in Clause 5 or that the work remains incomplete.</p> <p>This will also apply to items or group of items for which a separate period of completion has been specified.</p> <p>(i) Compensation @ 2 % per month of delay to be computed on per day basis for delay of work on quantum of damage suffered due to stated delay on the part of the contractor.</p> <p>Provided always that the total amount of compensation for delay to be paid under this Condition shall not exceed 10 % of the accepted Tendered Value of work or of the accepted Tendered Value of the Sectional part of work as mentioned in <b>Schedule „F“</b> for which a separate period of completion is originally given.</p> <p>In case no compensation has been decided by the authority in <b>Schedule „F“</b> during the progress of work, this shall be no waiver of right to levy compensation by the said authority if the work remains incomplete on final justified extended date of completion. If the Engineer-in-Charge decides to give further extension of time allowing performance of work beyond the justified extended date, the contractor shall be liable to pay compensation for such extended period. If any variation in amount of contract takes place during such extended period beyond justified extended date and the contractor becomes entitled to additional time under clause 12, the net period for such variation shall be accounted for while deciding the period for levy of compensation. However, during such further extended period beyond the justified extended period, if any delay occurs by events under sub clause 5.2, the contractor shall be liable to pay compensation for such delay.</p> <p>Provided that compensation during the progress of work before the justified extended date of completion for delay under this clause shall be for non-achievement of sectional completion or part handing over of work on stipulated/justified extended date for such part work or if delay affects any other works/services. This is without prejudice to right of action by the Engineer-in-Charge under clause 3 for delay in performance and claim of compensation under that clause.</p> <p>In case action under clause 2 has not been finalized and the work has been determined</p>

	<p>under clause 3, the right of action under this clause shall remain post determination of contract but levy of compensation shall be for days the progress is behind the schedule on date of determination, as assessed by the authority in <b>Schedule F</b>, after due consideration of justified extension. The compensation for delay, if not decided before the determination of contract, shall be decided after of determination of contract.</p> <p>The amount of compensation may be adjusted or set-off against any sum payable to the Contractor under this or any other contract with U.P. Jal Nigam. In case, the contractor does not achieve a particular milestone mentioned in <b>Schedule F</b>, or the re-scheduled milestone(s) in terms of Clause 5.4, the amount shown against that milestone shall be withheld, to be adjusted against the compensation levied as above. With-holding of this amount on failure to achieve a milestone, shall be automatic without any notice to the contractor. However, if the contractor catches up with the progress of work on the subsequent milestone(s), the withheld amount shall be released. In case the contractor fails to make up for the delay in subsequent milestone(s), amount mentioned against each milestone missed subsequently also shall be withheld. However, no interest, whatsoever, shall be payable on such withheld amount.</p>
<p><b>When Contract can be Determined</b></p>	<p><b>CLAUSE 3</b></p> <p>Subject to other provisions contained in this clause, the Engineer-in-Charge may, without prejudice to his any other rights or remedy against the contractor in respect of any delay, inferior workmanship, any claims for damages and/or any other provisions of this contract or otherwise, and whether the date of completion has or has not elapsed, by notice in writing absolutely determine the contract in any of the following cases:</p> <ol style="list-style-type: none"> <li>i. If the contractor having been given by the Engineer-in-Charge a notice in writing to rectify, reconstruct or replace any defective work or that the work is being performed in an inefficient or otherwise improper or un-workman like manner shall omit to comply with the requirement of such notice for a period of seven days thereafter.</li> <li>ii. If the contractor has, without reasonable cause, suspended the progress of the work or has failed to proceed with the work with due diligence and continues to do so after a notice in writing of seven days from the Engineer-in-Charge.</li> <li>iii. If the contractor fails to complete the work or section of work with individual date of completion on or before the stipulated or justified extended date, on or before such date of completion; and the Engineer in Charge without any prejudice to any other right or remedy under any other provision in the contract has given further reasonable time in a notice given in writing in that behalf as either mutually agreed or in absence of such mutual agreement by his own assessment making such time essence of contract and in the opinion of Engineer-in-Charge the contractor will be unable to complete the same or does not complete the same within the period specified.</li> <li>iv. If the contractor persistently neglects to carry out his obligations under the contract and/ or commits default in complying with any of the terms and conditions of the contract and does not remedy it or take effective steps to remedy it within 7 days after a notice in writing is given to him in that behalf by the Engineer-in-Charge.</li> <li>v. If the contractor shall offer or give or agree to give to any person in U.P. Jal Nigam (Urban) or to any other person on his behalf any gift or consideration of any kind as</li> </ol>

	<p>an inducement or reward for doing or forbearing to do or for having done or forborne to do any act in relation to the obtaining or execution of this or any other contract for U.P. Jal Nigam(Urban).</p> <p>vi. If the contractor shall enter into a contract with U.P. Jal Nigam (Urban) in connection with which commission has been paid or agreed to be paid by him or to his knowledge, unless the particulars of any such commission and the terms of payment thereof have been previously disclosed in writing to the Engineer-in-Charge.</p> <p>vii. If the contractor had secured the contract with U.P. Jal Nigam(Urban) as a result of wrong tendering or other non-bonafide methods of competitive tendering or commits breach of Integrity Agreement.</p> <p>viii. If the contractor being an individual, or if a firm, any partner thereof shall at any time be adjudged insolvent or have a receiving order or order for administration of his estate made against him or shall take any proceedings for liquidation or composition (other than a voluntary liquidation for the purpose of amalgamation or reconstruction) under any Insolvency Act for the time being in force or make any conveyance or assignment of his effects or composition or arrangement for the benefit of his creditors or purport so to do, or if any application be made under any Insolvency Act for the time being in force for the sequestration of his estate or if a trust deed be executed by him for benefit of his creditors.</p> <p>ix. If the contractor being a company shall pass a resolution or the court shall make an order that the company shall be wound up or if a receiver or a manager on behalf of a creditor shall be appointed or if circumstances shall arise which entitle the court or the creditor to appoint a receiver or a manager or which entitle the court to make a winding up order.</p> <p>x. If the contractor shall suffer an execution being levied on his goods and allow it to be continued for a period of 21 days.</p> <p>xi. If the contractor assigns, (excluding part(s) of work assigned to other agency(s) by the contractor as per terms of contract), transfers, sublets (engagement of labour on a piece-work basis or of labour with materials not to be incorporated in the work, shall not be deemed to be subletting) or otherwise parts with or attempts to assign, transfer, sublet or otherwise parts with the entire works or any portion thereof without the prior written approval of the Engineer -in-Charge.</p> <p>When the contractor has made himself liable for action under any of the cases aforesaid, the Engineer-in-Charge on behalf of the U.P. Jal Nigam(Urban) shall have powers:</p> <p>a) To determine the contract as aforesaid so far as performance of work by the Contractor is concerned (of which determination notice in writing to the contractor under the hand of the Engineer-in-Charge shall be conclusive evidence). Upon such determination, the Earnest Money Deposit, Security Deposit already recovered and Performance Guarantee under the contract shall be liable to be forfeited and shall be absolutely at the disposal of U.P. Jal Nigam(Urban).</p> <p>b) After giving notice to the contractor to measure up the work of the contractor and to take such whole, or the balance or part thereof, as shall be un-executed</p>
--	---

	<p>out of his hands and to give it to another contractor to complete the work. The contractor, whose contract is determined as above, shall not be allowed to participate in the tendering process for the balance work including any new items needed to complete the work.</p> <p>In the event of above courses being adopted by the Engineer-in-Charge, the contractor shall have no claim to compensation for any loss sustained by him by reasons of his having purchased or procured any materials or entered into any engagements or made any advances on account or with a view to the execution of the work or the performance of the contract. And in case action is taken under any of the provision aforesaid, the contractor shall not be entitled to recover or be paid any sum for any work thereof or actually performed under this contract unless and until the Engineer-in-Charge has certified in writing the performance of such work and the value payable in respect thereof and he shall only be entitled to be paid the value so certified.</p>
	<p><b>CLAUSE 3A</b></p> <p>In case, the work cannot be started due to reasons not within the control of the contractor within 1/8th of the stipulated time for completion of work or one month whichever is more, either party may close the contract by giving notice to the other party stating reasons. In such eventuality, the Performance Guarantee of the contractor shall be refunded within following time limits :</p> <p>(i) If the Tendered value of work is up to Rs. 1 Crore : 15 days</p> <p>(ii) If the Tendered value of work is more than Rs. 1 Crore and up to Rs. 10 Crore : 21 days.</p> <p>(iii) If the Tendered value of work exceeds Rs. 10 Crore : 30 days</p> <p>Neither party shall claim any compensation for such eventuality. This clause is not applicable for any breach of the contract by either party.</p>
<p><b>Contractor liable to pay Compensation even if action not taken under Clause 3</b></p>	<p><b>CLAUSE 4</b></p> <p>In any case in which any of the powers conferred upon the Engineer-in-Charge by Clause-3 thereof, shall have become exercisable and the same are not exercised, the non-exercise thereof shall not constitute a waiver of any of the conditions hereof and such powers shall notwithstanding be exercisable in the event of any future case of default by the contractor and the liability of the contractor for compensation shall remain unaffected. In the event of the Engineer-in-Charge putting in force all or any of the powers vested in him under the preceding clause he may, if he so desires after giving a notice in writing to the contractor, take possession of (or at the sole discretion of the Engineer-in-Charge which shall be final and binding on the contractor) use as on hire (the amount of the hire money being also in the final determination of the Engineer-in-Charge) all or any tools, plant, materials and stores, in or upon the works, or the site thereof belonging to the contractor, or procured by the contractor and intended to be used for the execution of the work/or any part thereof, paying or allowing for the same in account at the contract rates, or, in the case of these not being applicable, at current market rates to be certified by the Engineer-in-Charge, whose certificate thereof shall be final, and binding on the contractor, clerk of the works, foreman or other authorized agent to remove such tools, plant, materials, or stores from the premises (within a time to be specified in such notice) and in the event of the contractor failing to comply with any such requisition, the Engineer-in-Charge may remove them at</p>

	<p>the contractor's expense or sell them by auction or private sale on account of the contractor and his risk in all respects and the certificate of the Engineer-in-Charge as to the expenses of any such removal and the amount of the proceeds and expenses of any such sale shall be final and conclusive against the contractor.</p>
<p><b>Time and Extension for Delay</b></p>	<p><b>CLAUSE 5</b></p> <p>The time allowed for execution of the Works as specified in the <b>Schedule „F“</b> or the extended time in accordance with these conditions shall be the essence of the Contract. The execution of the works shall commence from such time period as mentioned in <b>Schedule „F“</b> or from the date of handing over of the site notified by the Engineer-in-Charge, whichever is later. If the Contractor commits default in commencing the execution of the work as aforesaid, the performance guarantee shall be forfeited by the Engineer in Charge and shall be absolutely at the disposal of U.P. Jal Nigam without prejudice to any other right or remedy available in law.</p> <p><b>5.1</b> As soon as possible but within <b>7 (Seven)</b> days of award of work and in consideration of:</p> <p>a) Schedule of handing over of site as specified in the <b>Schedule „F“</b>.</p> <p>The Contractor shall submit a Time and Progress Chart for each mile stone. In case the work is awarded on Trunkey basis wherein the contractor has to submit design and drawings, <i>it will also include timelines for submission of the same within over all time limit specified in <b>Schedule-F</b></i>. The Engineers-in-Charge may within 15 working days thereafter, if required, modify and communicate the program approved to the contractor failing which the program submitted by the contractor shall be deemed to be approved by the Engineer-in-Charge. The Chart shall be prepared in direct relation to the time stated in the Contract documents for completion of items of the works. It shall indicate the forecast of the dates of commencement and completion of various trades of sections of the work and may be amended as necessary by agreement between the Engineer-in-Charge and the Contractor within the limitations of time imposed in the Contract documents.</p> <p>i. In case of non-submission of construction programme by the contractor, the program approved by the Engineer-in-Charge shall be deemed to be final.</p> <p>ii. The approval by the Engineer-in-Charge of such programme shall not relieve the contractor of any of the obligations under the contract.</p> <p>iii. The contractor shall submit the Time and Progress Chart and progress report using the mutually agreed software or in other format decided by Engineer-in-Charge for the work done during previous month to the Engineer-in-charge on or before 5th day of each month failing which a recovery as per <b>Schedule F</b> to be decided by the NIT approving authority shall be made on per week or part basis in case of delay in submission of the monthly progress report.</p> <p><b>b) Minutes of Meeting:</b></p> <p>The Engineer may require the contractor to attend a progress review meeting during execution of work. The Engineer shall record the minutes of the meeting and provide a copy to the Contractor for compliance. These minutes may be a part of evidence in</p>

	<p>case of any request for extension of time or for action against the contractor.</p> <p><b>c) Accelerating the Pace of Work:</b>  The Engineer-in-charge, under some circumstances, may require the contractor to accelerate the pace of work by engaging labour in two shifts (including night shifts). Whenever such a request is made the contractor will cooperate with the Engineer-in-charge by mobilizing additional resources. However, the contractor shall neither be entitled for any incentive nor for any additional amount under this or any other clause.</p>
	<p><b>5.2</b> If the work(s) be delayed by: -</p> <ul style="list-style-type: none"> <li>(i) force majeure, or</li> <li>(ii) abnormally bad weather, or</li> <li>(iii) serious loss or damage by fire, or</li> <li>(iv) civil commotion, local commotion of workmen, strike or lockout, affecting any of the trades employed on the work, or</li> <li>(v) delay on the part of other contractors or tradesmen engaged by Engineer-in-Charge in executing work not forming part of the Contract, or</li> <li>(vi) any other cause like above which, in the reasoned opinion of the Engineer-in-Charge is beyond the Contractor's control.</li> </ul> <p>then upon the happening of any such event causing delay, the Contractor shall immediately give notice thereof in writing to the Engineer-in-Charge but shall nevertheless use constantly his best endeavours to prevent or make good the delay and shall do all that may be reasonably required to the satisfaction of the Engineer-in-Charge to proceed with the works.</p> <p>The contractor shall have no claim of damages for extension of time granted or rescheduling of milestone/s for events listed in sub clause 5.2.</p>
	<p><b>5.3</b> In case the work is hindered by U.P. Jal Nigam or any reasons/event for which U.P. Jal Nigam is responsible, the authority as indicated in <b>Schedule F</b> shall, if justified, give a fair and reasonable extension of time and reschedule the mile stones for completion of work. Such extension of time or rescheduling of milestone/s shall be without prejudice to any other right or remedy of the parties in contract or in law; provided further that for concurrent delays under this sub clause and sub clause 5.2 to the extent the delay is covered under sub clause 5.2 <b>the contractor shall be entitled to only extension of time and no damages.</b></p>
	<p><b>5.4</b> Request for rescheduling of Mile stones or extension of time shall be made by the Contractor in writing within fourteen days of the happening of the event causing delay on the prescribed forms to the authority as indicated in <b>Schedule F</b>. The Contractor shall indicate in such a request the period by which rescheduling of milestone/ s or extension of time is desired.</p> <p>With every request for rescheduling of milestones, or if at any time the actual progress of work falls behind the approved programme by more than 10% of the stipulated period of</p>

	<p>completion of contract, the contractor shall produce a revised programme which shall include all details of pending drawings and decisions required to complete the contract and also the target dates by which these details should be available without causing any delay in execution of the work. A recovery as specified in <b>Schedule F</b> shall be made on per day basis in case of delay in submission of the revised programme.</p> <p><b>5.4.1</b> In any such case the authority as indicated in <b>Schedule „F“</b> may give a fair and reasonable extension of time for completion of work or reschedule the mile stones. Such extension or rescheduling of the milestones shall be communicated to the Contractor by the authority as indicated in <b>Schedule F</b> in writing. In event of non-application by the contractor for extension of time Engineer-in-Charge after affording opportunity to the contractor, may give, supported with a programme (as specified under 5.4 above), a fair and reasonable extension within a reasonable period of occurrence of the event.</p>
	<p><b>5.5</b> In case the work is delayed by any reasons, in the opinion of the Engineer-in-Charge, by the contractor for reasons beyond the events mentioned in clause 5.2 or clause 5.3 or clause 5.4 and beyond the justified extended date; without prejudice to right to take action under Clause 3, the Engineer-in-Charge may grant extension of time required for completion of work without rescheduling of milestones. The contractor shall be liable for levy of compensation for delay for such extension of time.</p>
<p><b>Measurements of Work Done</b></p>	<p><b>CLAUSE 6</b></p> <p>Engineer-in-Charge shall, except as otherwise provided, ascertain and determine by measurement, the value in accordance with the contract of work done.</p> <p>All measurement of all items having financial value shall be entered in Measurement Book and/or level field book so that a complete record is obtained of all works performed under the contract.</p> <p>All measurements and levels shall be taken jointly by the Engineer-in-Charge or his authorized representative and by the contractor or his authorized representative on measurement books from time to time during the progress of the work and such measurements shall be signed and dated by the Engineer-in-Charge or his authorised representative and the contractor or their representatives in token of their acceptance. If the contractor objects to any of the measurements recorded, a note shall be made to that effect with reason and signed by both the parties.</p> <p>If for any reason the contractor or his authorized representative is not available and the work of recording measurements is suspended by the Engineer-in-Charge or his representative, the Engineer-in-Charge and U.P. Jal Nigam shall not entertain any claim from contractor for any loss or damages on this account. If the contractor or his authorized representative does not remain present at the time of such measurements after the contractor or his authorized representative has been given a notice in writing three (3) days in advance or fails to countersign or to record objection within a week from the date of the measurement, then such measurements recorded in his absence by the Engineer-in-Charge or his representative shall be deemed to be accepted by the Contractor.</p> <p>The contractor shall, without extra charge, provide all assistance with every appliance,</p>

	<p>labour and other things necessary for measurements and recording levels.</p> <p>Except where any general or detailed description of the work expressly shows to the contrary, measurements shall be taken in accordance with the procedure set forth in the specifications notwithstanding any provision in the relevant Standard Method of measurement or any general or local custom. In the case of items which are not covered by specifications, measurements shall be taken in accordance with the relevant standard method of measurement issued by the Bureau of Indian Standards and if for any item no such standard is available, then a mutually agreed method shall be followed.</p> <p>The contractor shall give, not less than seven days" notice to the Engineer-in-Charge or his authorized representative in charge of the work, before <b>covering up</b> or otherwise placing beyond the reach of measurement any work in order that the same may be measured and correct dimensions thereof be taken before the same is covered up or placed beyond the reach of measurement and shall not cover up and place beyond reach of measurement any work without consent in writing of the Engineer-in-Charge or his authorized representative in charge of the work who shall within the aforesaid period of seven days inspect the work, and if any work shall be covered up or placed beyond the reach of measurements without such notice having been given or the Engineer-in-Charge"s consent being obtained in writing, the same shall be uncovered at the Contractor"s expense, or in default thereof no payment or allowance shall be made for such work or the materials with which the same was executed.</p> <p>Engineer-in-Charge or his authorized representative may cause either themselves or through another officer of U.P. Jal Nigam to check the measurements recorded jointly or otherwise as aforesaid and all provisions stipulated herein above shall be applicable to such checking of measurements or levels.</p> <p>It is also a term of this contract that recording of measurements of any item of work in the measurement book and/or its payment in the interim, on account or final bill shall not be considered as conclusive evidence as to the sufficiency of any work or material to which it relates nor shall it relieve the contractor from liabilities from any over measurement or defects noticed till completion of the defects liability period.</p>
<p><b>Computerized Measurement Book</b></p>	<p><b>CLAUSE 6A</b></p> <p>Engineer-in-Charge shall, except as otherwise provided, ascertain and determine by measurement the value of work done in accordance with the contract.</p> <p>All measurements of all items having financial value shall be entered by the contractor and compiled in the shape of the Computerized Measurement Book having pages of A-4 size as per the format of U.P. Jal Nigam so that a complete record is obtained of all the items of works performed under the contract.</p> <p>All such measurements and levels recorded by the contractor or his authorized representative from time to time, during the progress of the work, shall be got checked by the contractor from the Engineer-in-Charge or his authorized representative as per interval or program fixed in consultation with Engineer-in-Charge or his authorized representative. After the necessary corrections made by the Engineer-in-Charge, the measurement sheets shall be returned to the contractor for incorporating the corrections and for resubmission to the Engineer-in-Charge for the dated signatures by the Engineer-in-Charge and the</p>

contractor or their representatives in token of their acceptance.

Whenever bill is due for payment, the contractor would initially submit draft computerized measurement sheets and these measurements would be got checked/test checked from the Engineer-in-Charge and/or his authorized representative. The contractor will, thereafter, incorporate such changes as may be done during these checks/test checks in his draft computerized measurements, and submit to U.P. Jal Nigam a computerized measurement book, duly bound, and with its pages machine numbered. The Engineer-in-Charge and/or his authorized representative would thereafter check this MB, and record the necessary certificates for their checks/test checks.

The final, fair, computerized measurement book given by the contractor, duly bound, with its pages machine numbered, should be 100% correct, and no cutting or over-writing in the measurements would thereafter be allowed. If at all any error is noticed, the contractor shall have to submit a fresh computerized MB with its pages duly machine numbered and bound, after getting the earlier MB cancelled by U.P. Jal Nigam. Thereafter, the MB shall be taken in the Divisional/Unit Office records, and allotted a number as per the Register of Computerised MBs. This should be done before the corresponding bill is submitted to the Divisional/Unit office for payment. The contractor shall submit two spare copies of such computerized MB"s for the purpose of reference and record by the various officers of U.P. Jal Nigam.

The contractor shall also submit to U.P. Jal Nigam separately his computerized Abstract of Cost and the bill based on these measurements, duly bound, and its pages machine numbered along with two spare copies of the bill. Thereafter, this bill will be processed by the Division/Unit office and allotted a number as per the computerized record in the same way as done for the measurement book meant for measurements.

The contractor shall, without extra charge, provide all assistance with every appliance, labour and other things necessary for checking of measurements/levels by the Engineer-in-Charge or his representative.

Except where any general or detailed description of the work expressly shows to the contrary, measurements shall be taken in accordance with the procedure set forth in the specifications notwithstanding any provision in the relevant Standard Method of measurement or any general or local custom. In the case of items which are not covered by specifications, measurements shall be taken in accordance with the relevant standard method of measurement issued by the Bureau of Indian Standards and if for any item no such standard is available then a mutually agreed method shall be followed.

The contractor shall give not less than seven days" notice to the Engineer-in-Charge or his authorized representative in charge of the work before **covering up** or otherwise placing beyond the reach of checking and/or test checking the measurement of any work in order that the same may be checked and/or test checked and correct dimensions thereof be taken before the same is covered up or placed beyond the reach of checking and/or test checking measurement and shall not cover up and place beyond reach of measurement any work without consent in writing of the Engineer-in-Charge or his authorized representative in charge of the work who shall within the aforesaid period of seven days inspect the work, and if any work shall be covered up or placed beyond the reach of checking and/or test checking measurements without such notice having been given or the Engineer-in-

	<p>Charge's consent being obtained in writing the same shall be uncovered at the Contractor's expense, or in default thereof no payment or allowance shall be made for such work or the materials with which the same was executed.</p> <p>Engineer-in-Charge or his authorized representative may cause either themselves or through another officer of U.P. Jal Nigam to check the measurements recorded by contractor and all provisions stipulated herein above shall be applicable to such checking of measurements or levels.</p> <p>It is also a term of this contract that checking and/or test checking the measurements of any item of work in the measurement book and/or its payment in the interim, on account of final bill shall not be considered as conclusive evidence as to the sufficiency of any work or material to which it relates nor shall it relieve the contractor from liabilities from any over measurement or defects noticed till completion of the defects liability period.</p>
<p><b>Payment on Intermediate Certificate to be Regarded as Advances</b></p>	<p><b>CLAUSE 7</b></p> <p>For payment interim or running account bills shall be submitted by the contractor for the work executed on the basis of such recorded measurements on the format of U.P. Jal Nigam in duplicate on or before the date of every month fixed for the same by the Engineer-in-Charge. The contractor shall not be entitled to be paid any such interim payment if the gross work done together with net payment/ adjustment of advances for material collected, if any, since the last such payment is less than the amount specified in <b>Schedule F</b>, in which case the interim bill shall be prepared on the appointed date of the month after the requisite progress is achieved. Engineer-in-Charge shall arrange to have the bill verified by taking or causing to be taken, where necessary, the requisite measurements of the work. In the event of the failure of the contractor to submit the bills, no claims whatsoever due to delays on payment including that of interest shall be payable to the contractor. Payment on account of amount admissible shall be made by the Engineer-in-Charge certifying the sum to which the contractor is considered entitled by way of interim payment at such rates as decided by the Engineer-in-Charge.</p> <p>The contractor should note that in many programmes the Govt./U.P. Jal Nigam have adopted <b>PFMS</b> system, wherein bills and other details are uploaded and thereafter payments are released. The Engineer-in-Charge may not have any control on the timeline for release of funds. The amount admissible and released shall, as far as possible, be paid by 7th working day after the day of release on PFMS.</p> <p>In other cases amount admissible shall, as far as possible, be paid by 15th working day after the day of presentation of the bill by the Contractor to the Engineer-in-Charge or his authorised together with the account of the material issued by U.P. Jal Nigam, or dismantled materials, if any. In the case of works outside the headquarters of the Engineer- in-Charge, the period of ten working days will be extended to thirty working days.</p> <p>All such interim payments shall be regarded as payment by way of advances against final payment only and shall not preclude the requiring of bad, unsound and imperfect or unskilled work to be rejected, removed, taken away and reconstructed or re-erected. Any certificate given by the Engineer-in-Charge relating to the work done or materials delivered forming part of such payment, may be modified or corrected by any subsequent</p>

	<p>such certificate(s) or by the final certificate and shall not by itself be conclusive evidence that any work or materials to which it relates is/are in accordance with the contract and specifications. Any such interim payment, or any part thereof shall not in any respect conclude, determine or affect in any way powers of the Engineer-in-Charge under the contract or any of such payments be treated as final settlement and adjustment of accounts or in any way vary or affect the contract.</p> <p>Pending consideration of extension of date of completion, interim payments shall continue to be made as herein provided without prejudice to the right of U.P. Jal Nigam to take action under the terms of this contract for delay in the completion of work, if the extension of date of completion is not granted by the competent authority.</p> <p>The Engineer-in-Charge in his sole discretion on the basis of a certificate from the Assistant Engineer/Project Engineer to the effect that the work has been completed up to the level in question make interim advance payments without detailed measurements for work done working out 75% of assessed value. The advance payments so allowed shall be adjusted in the subsequent interim bill to be submitted by the contractor.</p>
<p><b>Payments in composite Contracts</b></p>	<p>In case of composite tenders, running payment for the Civil components shall be made by Division/Unit Office of Civil works to the main contractor. Running payment for Electrical /Mechanical works may, at the discretion of U.P. Jal Nigam (Urban), be made by the Engineer-in-Charge of the relevant discipline directly to the main contractor.</p> <p><b>CLAUSE 7A</b></p> <p>No Running Account Bill shall be paid for the work till the applicable labour licenses, registration with EPFO, ESIC and BOCW Welfare Board, whatever applicable are submitted by the contractor to the Engineer-in-Charge.</p>
<p><b>Completion Certificate and Completion Plans</b></p>	<p><b>CLAUSE 8</b></p> <p>Within ten days of the completion of the work, the contractor shall give notice of such completion to the Engineer-in-Charge and within thirty days of the receipt of such notice, the Engineer-in-Charge shall inspect the work and if there is no defect in the work, shall furnish the contractor with a final certificate of completion, otherwise a provisional certificate of physical completion indicating defects (a) to be rectified by the contractor and/or (b) for which payment will be made at reduced rates, shall be issued. But no final certificate of completion shall be issued, nor shall the work be considered to be complete until the contractor shall has removed from the premises on which the work shall be executed all scaffolding, surplus materials, rubbish and all huts and sanitary arrangements required for his/their work people on the site in connection with the execution of the works as shall have been erected or constructed by the contractor(s) and cleaned off the dirt from all wood work, doors, windows, walls, floor or other parts of the building, in, upon, or about which the work is to be executed or of which he may have had possession for the purpose of the execution; thereof, and not until the work shall have been measured by the Engineer-in-Charge. If the contractor shall fail to comply with the requirements of this Clause as to removal of scaffolding, surplus materials and rubbish and all huts and sanitary arrangements as aforesaid and cleaning off dirt on or before the date fixed for the completion of work, the Engineer-in-Charge may at the expense of the contractor remove such scaffolding, surplus materials and rubbish etc., and dispose off the same as he thinks</p>

	fit and clean off such dirt as aforesaid, and the contractor shall have no claim in respect of scaffolding or surplus materials as aforesaid except for any sum actually realized by the sale thereof.
<b>Completion Plans to be Submitted by the Contractor and Works to be Handed Over to Client.</b>	<p><b>CLAUSE 8A</b></p> <p>The contractor shall submit completion plan/ as built drawings for Civil as well as Electrical/Mechanical works as applicable within thirty days of the completion of the work.</p> <p>In case, the contractor fails to submit the completion plan as aforesaid, he shall be liable to pay a sum of 0.1 % of accepted Tendered Value or limit prescribed in <b>Schedule F</b> whichever is more as may be fixed by the Superintending Engineer concerned and in this respect the decision of the Superintending Engineer shall be final and binding on the contractor.</p> <p><b>CLAUSE 8B</b></p> <p>The Contractor shall be responsible for safety of assets so created till the completed work has been duly handed over by him to the Client. The Defect Liability period shall commence only after handing over of the works.</p> <p>Provided that, in event of different Defects Liability Periods being applicable to different sections or parts of the permanent works, the expression Defects Liability Period shall, for the purposes of this contract, be deemed to mean the expiration of the latest of such periods. In this respect the decision of the NIT accepting authority shall be final and bonding on the contractor.</p>
<b>Payment of Final Bill</b>	<p><b>CLAUSE 9</b></p> <p>The final bill shall be submitted by the contractor in the same manner as specified in interim bills within three months of physical completion of the work or within one month of the date of the final certificate of completion furnished by the Engineer-in-Charge whichever is earlier. No further claims shall be made by the contractor after submission of the final bill and these shall be deemed to have been waived and extinguished. Payments of those items of the bill in respect of which there is no dispute and of items in dispute, for quantities and rates as approved by Engineer-in-Charge, will, as far as possible be made within the period specified hereinunder, the period being reckoned from the date of receipt of the bill by the Engineer-in-Charge or his authorized Asstt. Engineer/Project Engineer, complete with account of materials issued by U.P. Jal Nigam and dismantled materials.</p> <p>(i) If the Tendered value of work is up to Rs. 1 Crore : 2 months</p> <p>(ii) If the Tendered value of work is more than Rs. 1 Crore and up to Rs 10 Crore: 3 months</p> <p>(iii) If the Tendered value of work exceeds Rs. 10 Crore : 6 months</p>
<b>Payment of Contractor's Bills to Banks</b>	<p><b>CLAUSE 9A</b></p> <p>Payments due to the contractor may, if so desired by him, or if so instructed by the lending bank be made to his bank, recognized financial institutions instead of direct to him</p>

	<p>provided that the contractor furnishes to the Engineer-in-Charge (1) an authorization in the form of a legally valid document such as a power of attorney conferring authority on the bank; recognized financial institutions to receive payments and (2) his own acceptance of the correctness of the amount made out as being due to him by U.P. Jal Nigam or his signature on the bill or other claim preferred against U.P. Jal Nigam before settlement by the Engineer-in-Charge of the account or claim by payment to the bank or recognized financial institutions. While the receipt given by such banks or recognized financial institutions shall constitute a full and sufficient discharge for the payment, the contractor shall whenever possible present his bills duly receipted and discharged through his banks or recognized financial institutions.</p> <p>Nothing herein contained shall operate to create in favour of the bank or recognized financial institutions any rights or equities vis-a-vis U P Jal Nigam.</p>
<p><b>Materials supplied by U.P. Jal Nigam (Urban)</b></p>	<p><b>CLAUSE 10 (Not applicable for Turnkey Projects)</b></p> <p>Materials which U.P. Jal Nigam (Urban) will supply are shown in <b>Schedule B</b> which also stipulates quantum, place of issue and rate(s) to be charged in respect thereof. The contractor shall be bound to procure them from the Engineer-in-Charge.</p> <p>As soon as the work is awarded, the contractor shall finalise the programme for the completion of work as per clause 5 of this contract and shall give his estimates of materials required on the basis of drawings/or bill of quantities of the work. The Contractor shall give in writing his requirement to the Engineer-in-Charge which shall be issued to him keeping in view the progress of work as assessed by the Engineer-in-Charge, in accordance with the agreed phased programme of work indicating monthly requirements of various materials. The contractor shall place his indent in writing for issue of such materials at least 7 days in advance of his requirement.</p> <p>Such materials shall be supplied for the purpose of the contract only and the value of the materials so supplied at the rates specified in the aforesaid schedule shall be set off or deducted, as and when materials are consumed in items of work (including normal wastage) for which payment is being made to the contractor, from any sum then due or which may therefore become due to the contractor under the contract or otherwise or from the security deposit. At the time of submission of bills, the contractor shall certify that balance of materials supplied is available at site in original good condition.</p> <p>The contractor shall submit along with every running bill (on account or interim bill) material wise reconciliation statements supported by complete calculations reconciling total issue, total consumption and certified balance (diameter/section-wise in the case of steel) and resulting variations and reasons therefore. Engineer-in-Charge shall (whose decision shall be final and binding on the contractor) be within his rights to follow the procedure of recovery in clause 42 at any stage of the work if reconciliation is not found to be satisfactory.</p> <p>The contractor shall bear the cost of getting the material issued, loading, transporting to site, unloading, storing under cover as required, cutting assembling and joining the several parts together as necessary. Notwithstanding anything to the contrary contained in any other clause of the contract all stores/materials so supplied to the contractor or procured with the assistance of U.P. Jal Nigam shall remain the absolute property of U.P. Jal Nigam</p>

	<p>and the contractor shall be the trustee of the stores/materials, and the said stores/materials shall not be removed/disposed off from the site of the work on any account and shall be at all times open to inspection by the Engineer-in-Charge or his authorized agent. Any such stores/materials remaining unused shall be returned to the Engineer-in Charge in as good a condition in which they were originally supplied at a place directed by him, at a place of issue or any other place specified by him as he shall require, but in case it is decided not to take back the stores/materials the contractor shall have no claim for compensation on any account of such stores/materials so supplied to him as aforesaid and not used by him or for any wastage in or damage to in such stores/materials.</p> <p>On being required to return the stores/materials, the contractor shall hand over the stores/materials on being paid or credited such price as the Engineer-in-Charge shall determine, having due regard to the condition of the stores/materials. The price allowed for credit to the contractor, however, shall be at the prevailing market rate not exceeding the amount charged to him, excluding the storage charges, if any. The decision of the Engineer-in-Charge shall be final and conclusive. In the event of breach of the aforesaid condition, the contractor shall in addition to throwing himself open to account for contravention of the terms of the licences or permit and/or for criminal breach of trust, be liable to U.P. Jal Nigam for all advantages or profits resulting or which in the usual course would have resulted to him by reason of such breach. Provided that the contractor shall in no case be entitled to any compensation or damages on account of any delay in supply or non-supply thereof all or any such materials and stores provided further that the contractor shall be bound to execute the entire work if the materials are supplied by U.P. Jal Nigam within the original scheduled time for completion of the work plus 50% thereof or schedule time plus 6 months whichever is more if the time of completion of work exceeds 12 months, but if a part of the materials only has been supplied within the aforesaid period, then the contractor shall be bound to do so much of the work as may be possible with the materials and stores supplied in the aforesaid period. For the completion of the rest of the work, the contractor shall be entitled to such extension of time as may be determined by the Engineer-in-Charge whose decision in this regard shall be final and binding on the contractor.</p> <p>The contractor shall see that only the required quantities of materials are got issued. Any such material remaining unused and in perfectly good/original condition at the time of completion or determination of the contract shall be returned to the Engineer-in-Charge at the stores from which it was issued or at a place directed by him by a notice in writing. The contractor shall not be entitled for loading, transporting, unloading and stacking of such unused material except for the extra lead, if any involved, beyond the original place of issue.</p>
<p><b>Materials to be provided by the Contractor</b></p>	<p><b>CLAUSE 10A</b></p> <p>The contractor shall, at his own expense, provide all materials, required for the works other than those which are stipulated to be supplied by U.P. Jal Nigam (Urban).</p> <p>The contractor shall, at his own expense and without delay, supply to the Engineer-in-Charge samples of materials to be used on the work and shall get these approved in advance. All such materials to be provided by the Contractor shall be in conformity with the specifications laid down or referred to in the contract. The contractor shall, if</p>

	<p>requested by the Engineer-in Charge furnish proof, to the satisfaction of the Engineer-in-Charge that the materials so comply. The Engineer-in-Charge shall, within thirty days of supply of samples or within such further period as he may require intimate to the Contractor in writing whether samples are approved by him or not. If samples are not approved, the Contractor shall forthwith arrange to supply to the Engineer-in-Charge for his approval, fresh samples complying with the specifications laid down in the contract. When materials are required to be tested in accordance with specifications, approval of the Engineer-in-Charge shall be issued after the test results are received.</p> <p>The Contractor shall at his risk and cost submit the samples of materials to be tested or analyzed and shall not make use of or incorporate in the work any materials represented by the samples until the required tests or analysis have been made and materials finally accepted by the Engineer-in-Charge. The Contractor shall not be eligible for any claim or compensation either arising out of any delay in the work or due to any corrective measures required to be taken on account of and as a result of testing of materials.</p> <p>The contractor shall, at his risk and cost, make all arrangements and shall provide all facilities as the Engineer-in-Charge may require for collecting, and preparing the required number of samples for such tests at such time and to such place or places as may be directed by the Engineer-in-Charge and bear all charges and cost of testing unless specifically provided for otherwise elsewhere in the contract or specifications. The Engineer-in-Charge or his authorized representative shall at all times have access to the works and to all workshops and places where work is being prepared or from where materials, manufactured articles or machinery are being obtained for the works and the contractor shall afford every facility and every assistance in obtaining the right to such access.</p> <p>The Engineer-in-Charge shall have full powers to require the removal from the premises of all materials which in his opinion are not in accordance with the specifications and in case of default, the Engineer-in-Charge shall be at liberty to employ at the expense of the contractor, other persons to remove the same without being answerable or accountable for any loss or damage that may happen or arise to such materials. The Engineer-in-Charge shall also have full powers to require other proper materials to be substituted thereof and in case of default, the Engineer-in-Charge may cause the same to be supplied and all costs which may attend such removal and substitution shall be borne by the Contractor.</p> <p>The contractor shall at his own expense, provide a material testing lab at the site for conducting routine field tests. The lab shall be equipped at least with the testing equipment as specified in <b>Schedule F</b>.</p>
<p><b>Secured Advance on Non-perishable Materials</b></p>	<p><b>CLAUSE 10B</b></p> <p>(i) The contractor, on signing an indenture in the form in (<b>Annexure-8</b>), shall be entitled to be paid during the progress of the execution of the work up to 75% of the assessed value (invoice value or market value whichever is less) of any materials which are in the opinion of the Engineer non-perishable, non-fragile and non-combustible (such as Pipes, Transformers, Pumps, Motors, Starters, Cables, DG Sets, Electric Panels etc.) and are in accordance with the contract and which have been brought on the site in connection therewith and are adequately stored and/or protected against damage by weather or other causes but which have not at the time of advance been incorporated in the works. This</p>

	<p>shall be subject to the following-</p> <ul style="list-style-type: none"> <li>a) Quantity of such material should not be more than 3 (three) months requirement.</li> <li>b) The materials supplied should be strictly as per specifications.</li> <li>c) The Contractor shall maintain records of indents, supply orders, challans, receipts and other records in a format approved by U.P. Jal Nigam. It will always remain open for inspection of Engineer or his authorised representatives.</li> <li>d) The Contractor shall submit monthly statements so that value of materials available at site may be ascertained.</li> <li>e) When materials on account of which an advance has been made under this sub-clause are incorporated in the work, the amount of such advance shall be recovered/ deducted from the next payment made under any of the clause or clauses of this contract.</li> </ul> <p><b>(Managing Director, U P Jal Nigam, Lucknow letter no.968/Pra-1/2005-0021/19 dated 29.08.2019)</b></p>
<p><b>Mobilisation Advance</b> <b>(Applicable for Contract value being more than Rs. 5 Crores)</b></p>	<p>(ii) The Engineer-in-Charge shall make interest free mobilization advance payment to the Contractor equal to 10% of contracted amount on Contractor's demand and submission of an Irrevocable Unconditional Bank Guarantee in a specified form (<b>Annexure-9</b>) and being issued by one of the scheduled commercial banks and branch acceptable to the Employer in amounts and currencies equal to 100% of the advanced payment. Such advance shall be subject to the following conditions:</p> <ul style="list-style-type: none"> <li>a) Mobilization advance shall be issued only after verification of the Bank Guarantee.</li> <li>b) Such advance shall be made in two equal instalments, out of this 5% amount shall be paid within 30 days of execution of agreement and balance 5% advance shall be paid after construction of contractor's site office, deployment of human resources and machineries and equipments required for the project.</li> <li>c) The firm shall within 3 months of receiving such advance, utilise it for the specific purpose for which it has been sanctioned, failing which, interest at the rate of 8% per annum shall be recovered from the date of issuing the advance, as if it was an interest bearing advance.</li> <li>d) In case the said work is not completed within a period of 6 (six) months of receiving first instalment of mobilization advance, the entire advance along with accrued interest @ 8% per annum shall be recovered by forfeiture of the Bank Guarantee.</li> <li>e) In case the Contractor is able to complete the work within a period of six months for which advance has been sanctioned, the advanced amount shall be recovered from 7th month in such a way that the entire advance is recovered by the end of 12 months. No interest shall be levied in such cases.</li> <li>f) The aforesaid Bank Guarantee shall remain effective until the advance payment has been repaid, but the amount of the Guarantee shall be progressively reduced by the amount repaid by the Contractor. However the contractor may, at his option, submit required amount of Bank Guarantee in not more than 3(three) parts for each instalment of Mobilization Advance made available to him. In any case such number of Bank Guarantees shall be limited to 6 (six).</li> <li>g) If the Contract is terminated due to default of the contractor, under such circumstances outstanding mobilization advance along with interest on the entire</li> </ul>

	<p>value of mobilization advance shall be recovered at the compounded interest of 8% calculated quarterly.</p> <p>h) Provided always that, if any amount becomes due to the department as a consequence of any of the above clauses and if such amount is not recoverable from the encashment of Bank Guarantees, it will be recovered from any other amount due to the contractor or from security deposit under the contract.</p>
<b>Interest &amp; Recovery</b>	(iii) If the circumstances are considered reasonable by the Engineer-in-Charge, the period mentioned in (i) for request by the contractor in writing for grant of secured advance may be extended in the discretion of the Engineer-in-Charge.
<b>Dismantled Material Govt. Property</b>	<p><b>CLAUSE 10 C</b></p> <p>The contractor shall treat all materials obtained during dismantling of a structure, excavation of the site for a work, etc. as Government's property and such materials shall be disposed off to the best advantage of Government according to the instructions in writing issued by the Engineer-in-Charge.</p>
<b>Work to be Executed in Accordance with Specifications, Drawings, Orders etc.</b>	<p><b>CLAUSE 11</b></p> <p>The contractor shall execute the whole and every part of the work in the most substantial and workmanlike manner both as regards materials and otherwise in every respect in strict accordance with the specifications. The contractor shall also conform exactly, fully and faithfully to the design, drawings and instructions in writing in respect of the work signed by the Engineer-in-Charge and the contractor shall be furnished free of charge one copy of the contract documents together with specifications, designs, drawings and instructions as are not included in the standard specifications specified in section of <b>Specifications</b> and/or <b>Schedule F</b> or in any Bureau of Indian Standard or any other, published standard or code or, Schedule of Rates or any other printed publication referred to elsewhere in the contract.</p> <p>The contractor shall comply with the provisions of the contract and with the care and diligence execute and maintain the works and provide all labour and materials, tools and plants including for measurements and supervision of all works, structural plans and other things of temporary or permanent nature required for such execution and maintenance in so far as the necessity for providing these, is specified or is reasonably inferred from the contract. The Contractor shall take full responsibility for adequacy, suitability and safety of all the works and methods of construction.</p>
<b>Deviations/ Variations Extent and Pricing</b>	<p><b>CLAUSE 12 :</b></p> <p>The Engineer-in-Charge shall have power (i) to make alteration in, omissions from, additions to, or substitutions for the original specifications, drawings, designs and instructions that may appear to him to be necessary or advisable during the progress of the work, and (ii) to omit a part of the works in case of non-availability of a portion of the site or for any other reasons and the contractor shall be bound to carry out the works in accordance with any instructions given to him in writing signed by the Engineer-in-Charge (after due approval of competent authority) and such alterations, omissions, additions or substitutions shall form part of the contract as if originally provided therein and any</p>

	<p>altered, additional or substituted work which the contractor may be directed to do in the manner specified above as part of the works, shall be carried out by the contractor on the same conditions in all respects including price on which he agreed to do the main work except as hereafter provided.</p> <p><b>12.1</b> The time for completion of the works shall, in the event of any deviations resulting in additional cost over the accepted tendered value sum being ordered, be extended, if requested by the contractor, as follows :</p> <p>(i) In the proportion which the additional cost of the altered, additional or substituted work, bears to the original tendered value plus</p> <p>(ii) 25% of the time calculated in (i) above or such further additional time as may be considered reasonable by the Engineer-in-Charge.</p>
<p><b>Deviation, Extra Items and Pricing</b></p>	<p><b>12.2</b> (i) In the case of extra item(s) (items that are completely new, and are in addition to the items contained in the contract), the contractor may within fifteen days of receipt of order or occurrence of the item(s) claim rates, supported by proper analysis, which shall include invoices, vouchers etc. and Manufacturer's specification for the work failing which the rate approved later by the Engineer- in- charge (after due approval of competent authority) shall be binding and the Engineer-in-Charge (after due approval of competent authority) shall within prescribed time limit of the receipt of the claims supported by analysis, after giving consideration to the analysis of the rates submitted by the contractor, determine the rates on the basis of the applicable S.O.R./market rates and the contractor shall be paid in accordance with the rates so determined, failing which it will be deemed to have been approved.</p>
<p><b>Deviation, Substituted Items, Pricing</b></p>	<p>(ii) In the case of substituted items (items that are taken up with partial substitution or in lieu of items of work in the contract), the rate for the agreement item (to be substituted) and substituted item shall also be determined in the manner as mentioned in the following para.</p> <p>(a) If the S.O.R./market rate for the substituted item so determined is more than the market rate of the agreement item (to be substituted), the rate payable to the contractor for the substituted item shall be the rate for the agreement item (to be substituted) so increased to the extent of the difference between the market rates of substituted item and the agreement item (to be substituted).</p> <p>(b) If the S.O.R. / market rate for the substituted item so determined is less than the market rate of the agreement item (to be substituted), the rate payable to the contractor for the substituted item shall be the rate for the agreement item (to be substituted) so decreased to the extent of the difference between the market rates of substituted item and the agreement item (to be substituted).</p>
<p><b>Deviation, Deviated Quantities, Pricing</b></p>	<p>(iii) In the case of contract items, substituted items, contract cum substituted items, which exceed the limits laid down in <b>Schedule F</b>, the contractor may within fifteen days of receipt of order or occurrence of the excess, claim revision of the rates, supported by proper analysis for the work in excess of the above mentioned limits, provided that if</p>

	<p>the rates so claimed are in excess of the rates specified in the bill of quantities, the Engineer-in-Charge shall within prescribed time limit of receipt of the claims supported by analysis, after giving consideration to the analysis of the rates submitted by the contractor, after due approval of competent authority determine the rates on the basis of the market rates (as per UPPWD/UPJN/CPWD schedules, invoice, vouchers from the manufacturers or suppliers submitted by the agency and duly verified by Engineer-in-Charge or his representative) and the contractor shall be paid in accordance with the rates so determined.</p> <p>The prescribed time limit for finalizing rates for Extra Item(s), Substitute Item(s) and Deviated Quantities of contract items is within 45 days after submission of proposal by the contractor without observation of the Engineer-in-Charge.</p> <p><b>12.3</b> The provisions of the preceding paragraph shall also apply to the decrease in the rates of items for the work in excess of the limits laid down in <b>Schedule F</b>, and the Engineer-in-Charge shall after giving notice to the contractor within one month of occurrence of the excess and after taking into consideration any reply received from him within fifteen days of the receipt of the notice, after approval of competent authority, revise the rates for the work in question within one month of the expiry of the said period of fifteen days having regard to the market rates.</p> <p><b>12.4</b> For the purpose of operation of <b>Schedule F</b>, the following works shall be treated as works relating to foundation unless &amp; otherwise defined in the contract:</p> <ol style="list-style-type: none"> <li>i. For Buildings : All works up to 1.2 metres above ground level or up to floor 1 level whichever is lower.</li> <li>ii. For abutments, piers and well staining : All works up to 1.2 m above the bed level.</li> <li>iii. For retaining walls, wing walls, compound walls, chimneys, over head reservoirs/tanks and other elevated structures : All works up to 1.2 metres above the ground level.</li> <li>iv. For reservoirs/tanks (other than overhead reservoirs/tanks) : All works up to 1.2 metres above the ground level.</li> <li>v. For basement: All works up to 1.2 m above ground level or up to floor 1 level whichever is lower.</li> <li>vi. For Roads, all items of excavation and filling including treatment of sub base.</li> </ol> <p><b>12.5</b> Any operation incidental to or necessarily has to be in contemplation of tenderer while quoting tender, or necessary for proper execution of the item included in the Bill of quantities or in the schedule of rates mentioned above, whether or not, specifically indicated in the description of the item and the relevant specifications, shall be deemed to be included in the rates quoted by the tenderer or the rate given in the said schedule of rates, as the case may be. Nothing extra shall be admissible for such operations.</p>
<p><b>Foreclosure of contract due to Abandonment or Reduction in Scope of Work</b></p>	<p><b>CLAUSE 13</b></p> <p>If at any time after acceptance of the tender or during the progress of work, the purpose or object for which the work is being done changes due to any supervening cause and as a result of which the work has to be abandoned or reduced in scope the Engineer-in-Charge shall give notice in writing to that effect to the contractor stating the decision as well as the</p>

	<p>cause for such decision and the contractor shall act accordingly in the matter. The contractor shall have no claim to any payment of compensation or otherwise whatsoever, on account of any profit or advantage which he might have derived from the execution of the works in full but which he did not derive in consequence of the foreclosure of the whole or part of the works.</p> <p>The contractor shall be paid at contract rates for the works executed at site. If any materials supplied by U.P. Jal Nigam are rendered surplus, the same except normal wastage shall be returned by the contractor to U.P. Jal Nigam at rates not exceeding those at which these were originally issued, less allowance for any deterioration or damage which may have been caused whilst the materials were in the custody of the contractor. In addition, cost of transporting such materials from site to U.P. Jal Nigam stores, if so required by U.P. Jal Nigam, shall be paid.</p> <p>Provided always that against any payments due to the contractor on this account or otherwise, the Engineer-in-Charge shall be entitled to recover or be credited with any outstanding balances due from the contractor for advance paid in respect of any tool, plants and materials and any other sums which at the date of termination were recoverable by U.P. Jal Nigam from the contractor under the terms of the contract.</p> <p>In the event of action being taken under Clause 13 to reduce the scope of work, the contractor may furnish fresh Performance Guarantee on the same conditions, in the same manner and at the same rate for the balance tendered amount and initially valid up to the extended date of completion or stipulated date of completion if no extension has been granted plus 60 days beyond that. Wherever such a fresh Performance Guarantee is furnished by the contractor the Engineer-in-Charge may return the previous Performance Guarantee.</p>
<p><b>Carrying out part work at risk &amp; cost of contractor</b></p>	<p><b>Clause 14</b></p> <p>If contractor:</p> <ul style="list-style-type: none"> <li>(i) At any time makes default during currency of work or does not execute any part of the work with due diligence and continues to do so even after a notice in writing of 7 days in this respect from the Engineer-in-Charge; or</li> <li>(ii) Commits default in complying with any of the terms and conditions of the contract and does not remedy it or takes effective steps to remedy it within 7 days even after a notice in writing is given in that behalf by the Engineer-in-Charge; or</li> </ul> <p>Fails to complete the work(s) or items of work with individual dates of completion, on or before the date(s) so determined, and does not complete them within the period specified in the notice given in writing in that behalf by the Engineer-in-Charge.</p> <p>The Engineer- in-Charge without invoking action under clause 3 may, without prejudice to any other right or remedy against the contractor which have either accrued or accrue thereafter to U.P. Jal Nigam, by a notice in writing to take the part work / part incomplete work of any item(s) out of his hands and shall have powers to:</p> <ul style="list-style-type: none"> <li>(a) Take possession of the site and any materials, constructional plant, implements, stores, etc., thereon; and/or</li> <li>(b) Carry out the part work / part incomplete work of any item(s) by any means at</li> </ul>

	<p>the risk and cost of the contractor.</p> <p>The Engineer-in-Charge shall determine the amount, if any, is recoverable from the contractor for completion of the part work/ part incomplete work of any item(s) taken out of his hands and execute at the risk and cost of the contractor.</p> <p>In determining the amount, credit shall be given to the contractor with the value of work done in all respect in the same manner and at the same rate as if it had been carried out by the original contractor under the terms of his contract, the value of contractor's materials taken over and incorporated in the work and use of plant and machinery belonging to the contractor. The certificate of the Engineer-in-Charge as to the value of work done shall be final and conclusive against the contractor provided always that action under this clause shall only be taken after giving notice in writing to the contractor. Provided also that if the expenses incurred by U.P. Jal Nigam are less than the amount payable to the contractor at his agreement rates, the difference shall not be payable to the contractor.</p> <p>Any excess expenditure incurred or to be incurred by U.P. Jal Nigam in completing the part. work/ part incomplete work of any item(s) or the excess loss or damages suffered or may be suffered by U.P. Jal Nigam as aforesaid after allowing such credit shall without prejudice to any other right or remedy available to U.P. Jal Nigam in law or per as agreement be recovered from any money due to the contractor on any account, and if such money is insufficient, the contractor shall be called upon in writing and shall be liable to pay the same within 30 days.</p> <p>If the contractor fails to pay the required sum within the aforesaid period of 30 days, the Engineer-in-Charge shall have the right to sell any or all of the contractors' unused materials, constructional plant, implements, temporary building at site etc. and adjust the proceeds of sale thereof towards the dues recoverable from the contractor under the contract and if thereafter there remains any balance outstanding, it shall be recovered in accordance with the provisions of the contract.</p> <p>In the event of any of the above course being adopted by the Engineer-in-Charge, the contractor shall have no claim to compensation for any loss sustained by him by reason of his having purchased or procured any materials or entered into any engagements or made any advance on any account or with a view to the execution of the work or the performance of the contract.</p>
<p><b>Suspension of Work</b></p>	<p><b>CLAUSE 15</b></p> <p>(i) The contractor shall, on receipt of the order in writing of the Engineer-in-Charge, (whose decision shall be final and binding on the contractor) suspend the progress of the works or any part thereof for such time and in such manner as the Engineer-in-Charge may consider necessary so as not to cause any damage or injury to the work already done or endanger the safety thereof for any of the following reasons:</p> <ul style="list-style-type: none"> <li>(a) on account of any default on the part of the contractor or;</li> <li>(b) for proper execution of the works or part thereof for reasons other than the default of the contractor; or</li> <li>(c) for safety of the works or part thereof.</li> </ul> <p>The contractor shall, during such suspension, properly protect and secure the works to the</p>

	<p>extent necessary and carry out the instructions given in that behalf by the Engineer-in-Charge.</p> <p>(ii) If the suspension is ordered for reasons (b) and (c) in sub-para (i) above:</p> <p>(a) the contractor shall be entitled to an extension of time equal to the period of every such suspension PLUS 25%, for completion of the item or group of items of work for which a separate period of completion is specified in the contract and of which the suspended work forms a part.</p> <p>(iii) If the works or part thereof is suspended on the orders of the Engineer-in-Charge for more than six months at a time, except when suspension is ordered for reason (a) in sub-para (i) above, the contractor may after receipt of such order serve a written notice on the Engineer-in-Charge requiring permission within 15 (Fifteen) days from receipt by the Engineer- in-Charge of the said notice, to proceed with the work or part thereof in regard to which progress has been suspended and if such permission is not granted within that time, the contractor, if he intends to treat the suspension, where it affects only a part of the works as an omission of such part by U.P. Jal Nigam or where it affects whole of the works, as an abandonment of the works by U.P. Jal Nigam, shall within ten days of expiry of such period of 15 days give notice in writing of his intention to the Engineer-in-Charge. In the event of the contractor treating the suspension as an abandonment of the contract by U.P. Jal Nigam, he shall have no claim to payment of any compensation on account of any profit or advantage which he might have derived from the execution of the work in full but which he could not derive in consequence of the abandonment.</p>
<p><b>Compensation in case of Delay of Supply of Material by Govt.</b></p>	<p><b>CLAUSE 15 A</b></p> <p>The contractor shall not be entitled to claim any compensation from U.P. Jal Nigam for the loss suffered by him on account of delay by U.P. Jal Nigam in the supply of materials in <b>Schedule B</b>.</p> <p>This clause 15 A will not be applicable for works where no material is stipulated to be issued by U.P. Jal Nigam.</p>
<p><b>Action in case Work not done as per Specifications</b></p>	<p><b>CLAUSE 16</b></p> <p>All works under or in course of execution or executed in pursuance of the contract, shall at all times be open and accessible to the inspection and supervision of the Engineer-in-Charge, his authorized subordinates in charge of the work and all the superior officers, officers of Technical Audit Cell (TAC) / authorised Third Party Inspection agency or any organization engaged by U.P. Jal Nigam for Quality Assurance and the contractor shall, at all times, during the usual working hours and at all other times at which reasonable notice of the visit of such officers has been given to the contractor, either himself be present to receive orders and instructions or have a responsible agent duly accredited in writing, present for that purpose. Orders given to the Contractor’s agent shall be considered to have the same force as if they had been given to the contractor himself.</p> <p>If it shall appear to the Engineer-in-Charge or his authorized subordinates in charge of the work or to the superior officers, the officers of the organization engaged by U.P. Jal Nigam for Quality Assurance or to the TAC or its subordinate officers, that any work has been executed with unsound, imperfect, or unskillful workmanship, or with materials or articles</p>

	<p>provided by him for the execution of the work which are unsound or of a quality inferior to that contracted or otherwise not in accordance with the contract, the contractor shall, on demand in writing which shall be made within twelve months (six months in the case of work costing Rs. 10 Lac and below except road work) of the completion and handing over of the work from the Engineer-in-Charge specifying the work, materials or articles complained of notwithstanding that the same may have been passed, certified and paid for forthwith rectify, or remove and reconstruct the work so specified in whole or in part, as the case may require or as the case may be, remove the materials or articles so specified and provide other proper and suitable materials or articles at his own charge and cost. In the event of the failing to do so within a period specified by the Engineer-in-Charge in his demand aforesaid, then the contractor shall be liable to pay compensation at the same rate as under clause 2 of the contract (for non-completion of the work in time) for this default.</p> <p>In such case the Engineer-in-Charge may not accept the item of work at the rates applicable under the contract but may accept such items at reduced rates as the authority specified in <b>Schedule F</b> may consider reasonable during the preparation of on account bills or final bill if the item is so acceptable without detriment to the safety and utility of the item and the structure or he may reject the work outright without any payment and/or get it and other connected and incidental items rectified, or removed and re-executed at the risk and cost of the contractor. Decision of the Engineer-in-Charge to be conveyed in writing in respect of the same will be final and binding on the contractor.</p>
<p><b>Contractor Liable for Damages, defects during defect liability period/ Refund of Security Deposit.</b></p>	<p><b>CLAUSE 17</b></p> <p>If the contractor or his working people or servants shall break, deface, injure or destroy any part of building in which they may be working, or any structure, building, road, road kerb, fence, enclosure, water/sewer pipe, cables, drains, electric or telephone post or wires, trees, grass or grassland, or cultivated ground contiguous to the premises on which the work or any part is being executed, or if any damage shall happen to the work while in progress, from any cause whatever or if any defect, shrinkage or other faults appear in the work within defect liability period of the entire project arising out of defect or improper materials or workmanship the contractor shall upon receipt of a notice in writing on that behalf make the same good at his own expense or in default the Engineer-in-Charge cause the same to be made good by other workmen and deduct the expense from any sums that may be due or at any time thereafter may become due to the contractor, or from his security deposit or the proceeds of sale thereof or of a sufficient portion thereof.</p> <p>The security deposit/<b>performance security/performance guarantee</b> of the contractor shall not be refunded before the expiry of defect liability period of the entire project or till final bill has been passed, whichever is later.</p> <p>As the defect liability of Electrical-Mechanical works is two years from the date of handing over, the Engineer-in-Charge may, on the request of Contractor and at his discretion, retain out of security deposit an amount sufficient to cover up residual period of defect liability of Electrical-Mechanical works following the end of defect liability period of Civil Works.</p>
<p><b>Contractor to Supply Tools &amp;</b></p>	<p><b>CLAUSE 18</b></p> <p>The contractor shall provide at his own cost all materials (except such special materials, if</p>

<p><b>Plants etc.</b></p>	<p>any, as may in accordance with the contract be supplied from the Engineer-in-Charge's stores), machinery, tools &amp; plants as specified in <b>Schedule F</b>. In addition to this, appliances, implements, other plants, ladders, cordage, tackle, scaffolding and temporary works required for the proper execution of the work, whether original, altered or substituted and whether included in the specifications or other documents forming part of the contract or referred to in these conditions or not, or which may be necessary for the purpose of satisfying or complying with the requirements of the Engineer-in-Charge as to any matter as to which under these conditions he is entitled to be satisfied, or which he is entitled to require together with carriage therefore to and from the work. The contractor shall also supply without charge the requisite number of persons with the means and materials, necessary for the purpose of setting out works, and counting, weighing and assisting the measurement for examination at any time and from time to time of the work or materials. Failing his so doing, the same may be provided by the Engineer-in-Charge at the expense of the contractor and the expenses may be deducted, from any money due to the contractor, under this contract or otherwise and/or from his security deposit or the proceeds of sale thereof, or of a sufficient portion thereof.</p>
<p><b>Recovery of Compensation paid to Workmen</b></p>	<p><b>CLAUSE 18 A</b></p> <p>In every case in which by virtue of the provisions sub-section (1) of Section 12, of the Workmen's Compensation Act, 1923 as amended till date, U.P. Jal Nigam is obliged to pay compensation to a workman employed by the contractor, in execution of the works, U.P. Jal Nigam will recover from the contractor, the amount of the compensation so paid; and, without prejudice to the rights of U.P. Jal Nigam under sub-section (2) of Section 12, of the said Act, U.P. Jal Nigam shall be at liberty to recover such amount or any part thereof by deducting it from the security deposit or from any sum due by U.P. Jal Nigam to the contractor whether under this contract or otherwise. U.P. Jal Nigam shall not be bound to contest any claim made against it under sub-section (1) of Section 12, of the said Act, except on the written request of the contractor and upon his giving to U.P. Jal Nigam full security for all costs for which U.P. Jal Nigam might become liable in consequence of contesting such claim.</p>
<p><b>Ensuring Payment and Amenities to Workers if Contractor fails</b></p>	<p><b>CLAUSE 18 B</b></p> <p>In every case in which by virtue of the provisions of the Contract Labour (Regulation and Abolition) Act, 1970 as amended till date, and of the Contract Labour (Regulation and Abolition) Central Rules, 1971, U.P. Jal Nigam is obliged to pay any amounts of wages to a workman employed by the contractor in execution of the works, or to incur any expenditure in providing welfare and health amenities required to be provided under the above said Act and the rules under Clause 19H or under the Rules framed by Government from time to time for the protection of health and sanitary arrangements for workers employed by Contractors, U.P. Jal Nigam will recover from the contractor, the amount of wages so paid or the amount of expenditure so incurred; and without prejudice to the rights of U.P. Jal Nigam under sub-section(2) of Section 20, and sub-section (4) of Section 21, of the Contract Labour (Regulation and Abolition) Act, 1970, U.P. Jal Nigam shall be at liberty to recover such amount or any part thereof by deducting it from the security deposit or from any sum due by U.P. Jal Nigam to the contractor whether under this contract or otherwise U.P. Jal Nigam shall not be bound to contest any claim made against it under</p>

	<p>sub-section (1) of Section 20, sub-section (4) of Section 21, of the said Act, except on the written request of the contractor and upon his giving to U.P. Jal Nigam full security for all costs for which U.P. Jal Nigam might become liable in contesting such claim.</p>
<p><b>Labour Laws to be complied by the Contractor</b></p>	<p><b>CLAUSE 19</b></p> <p>The contractor shall obtain a valid licence under the Contract Labour (R&amp;A) Act, 1970, and the Contract Labour (Regulation and Abolition) Central Rules, 1971, before the commencement of the work, and continue to have a valid license until the completion of the work. The contractor shall also comply with provisions of the Inter-State Migrant Workmen (Regulation of Employment and Conditions of Service) Act, 1979.</p> <p>The contractor shall also abide by the provisions of the Child Labour (Prohibition and Regulation) Act, 1986.</p> <p>The contractor shall also comply with the provisions of the building and other Construction Workers (Regulation of Employment &amp; Conditions of Service) Act, 1996 and the building and other Construction Workers Welfare Cess Act, 1996.</p> <p>Any failure to fulfil these requirements shall attract the penal provisions of this contract arising out of the resultant non-execution of the work.</p> <p><b>CLAUSE 19A</b></p> <p>No labour below the age of fourteen years shall be employed on the work.</p>
<p><b>Payment of Wages</b></p>	<p><b>CLAUSE 19 B</b></p> <p>Payment of wages:</p> <p>(i) The contractor shall pay to labour employed by him either directly or through subcontractors, wages not less than fair wages as defined in State Govt. Contractor's Labour Regulations or as per the provisions of the Contract Labour (Regulation and Abolition) Act, 1970 and the contract Labour (Regulation and Abolition) Central Rules, 1971, wherever applicable.</p> <p>(ii) The contractor shall, notwithstanding the provisions of any contract to the contrary, cause to be paid fair wage to labour indirectly engaged on the work, including any labour engaged by his sub-contractors in connection with the said work, as if the labour had been immediately employed by him.</p> <p>(iii) In respect of all labour directly or indirectly employed in the works for performance of the contractor's part of this contract, the contractor shall comply with or cause to be complied with the contractor's Labour Regulations made by Government from time to time in regard to payment of wages, wage period, deductions from wages recovery of wages not paid and deductions unauthorizedly made, maintenance of wage books or wage slips, publication of scale of wages and other terms of employment, inspection and submission of periodical returns and all other matters of the like nature or as per the provisions of the Contract Labour (Regulation and Abolition) Act, 1970, and the Contract Labour (Regulation and Abolition) Central Rules, 1971, wherever applicable.</p> <p>(iv) (a) The Engineer-in-Charge concerned shall have the right to deduct from the moneys due to the contractor any sum required or estimated to be required for making good the loss suffered by a worker or workers by reason of non-fulfilment of the conditions</p>

	<p>of the contract for the benefit of the workers, non-payment of wages or of deductions made from his or their wages which are not justified by their terms of the contract or non-observance of the Regulations.</p> <p>(b) Under the provision of Minimum Wages (Central) Rules, 1950, or any other similar rules of the State Govt., the contractor is bound to allow to the labours directly or indirectly employed in the works one day rest for 6 days continuous work and pay wages at the same rate as for duty. In the event of default, the Engineer-in-Charge shall have the right to deduct the sum or sums not paid on account of wages for weekly holidays to any labours and pay the same to the persons entitled thereto from any money due to the contractor by the Engineer-in-Charge concerned.</p> <p>(v) The contractor shall comply with the provisions of the Payment of Wages Act, 1936, Minimum Wages Act, 1948, Employees Liability Act, 1938, Workmen’s Compensation Act, 1923, Industrial Disputes Act, 1947, Maternity Benefits Act, 1961, and the Contractor’s Labour (Regulation and Abolition) Act 1970, or the modifications thereof or any other laws relating thereto and the rules made thereunder from time to time.</p> <p>(vi) The contractor shall indemnify and keep indemnified U.P. Jal Nigam against payments to be made under and for the observance of the laws aforesaid and State Govt. Contractor’s Labour Regulations without prejudice to his right to claim indemnity from his sub-contractors.</p> <p>(vii) The laws aforesaid shall be deemed to be a part of this contract and any breach thereof shall be deemed to be a breach of this contract.</p> <p>(viii) Whatever is the minimum wage for the time being, or if the wage payable is higher than such wage, such wage shall be paid by the contractor to the workmen directly without the intervention of Jamadar and that Jamadar shall not be entitled to deduct or recover any amount from the minimum wage payable to the workmen as and by way of commission or otherwise.</p> <p>(ix) The contractor shall ensure that no amount by way of commission or otherwise is deducted or recovered by the Jamadar from the wage of workmen.</p>
	<p><b>CLAUSE 19C</b></p> <p>In respect of all labour directly or indirectly employed in the work for the performance of the contractor’s part of this contract, the contractor shall at his own expense arrange for the relevant safety provisions as per this contract or as may be ordered by the Engineer-in-Charge from from time to time and shall at his own expense provide for all facilities in connection therewith. In case the contractor fails to make arrangement and provide necessary facilities as aforesaid, he shall be liable to pay a penalty as decided by the authority mentioned in <b>Schedule F</b> for each default and in addition, the Engineer-in-Charge shall be at liberty to make arrangement and provide facilities as aforesaid and recover the costs incurred in that behalf from the contractor.</p> <p><b>CLAUSE 19 D</b></p> <p>The contractor shall submit by the 4th and 19th of every month, to the Engineer-in-Charge, a true statement showing in respect of the second half of the preceding month and the first half of the current month respectively: -</p>

	<p>(1) the number of labourers employed by him on the work,</p> <p>(2) their working hours,</p> <p>(3) the wages paid to them,</p> <p>(4) the accidents that occurred during the said fortnight showing the circumstances under which they happened and the extent of damage and injury caused by them, and</p> <p>(5) the number of female workers who have been allowed maternity benefit according to Clause 19F and the amount paid to them.</p> <p>Failing which the contractor shall be liable to pay to U.P. Jal Nigam, a sum as decided by the authority mentioned in <b>Schedule F</b> for each default or materially incorrect statement. The decision of the Divisional officer/Unit-in-charge shall be final in deducting from any bill due to the contractor, the amount levied as fine and be binding on the contractor.</p> <p><b>CLAUSE 19 E</b></p> <p>In respect of all labour directly or indirectly employed in the works for the performance of the contractor's part of this contract, the contractor shall comply with or cause to be complied with all the rules framed by Government from time to time for the protection of health and sanitary arrangements for workers employed by U.P. Jal Nigam and its contractors.</p>
	<p><b>CLAUSE 19 F</b></p> <p>Leave and pay during leave shall be regulated as follows: -</p> <p>1. Leave:</p> <p>(i) in the case of delivery - maternity leave not exceeding 8 weeks, 4 weeks up to and including the day of delivery and 4 weeks following that day,</p> <p>(ii) in the case of miscarriage - upto 3 weeks from the date of miscarriage.</p> <p>2. Pay:</p> <p>(i) in the case of delivery - leave pay during maternity leave will be at the rate of the women's average daily earnings, calculated on total wages earned on the days when full time work was done during a period of three months immediately preceding the date on which she gives notice that she expects to be confined.</p> <p>(ii) in the case of miscarriage - leave pay at the rate of average daily earning calculated on the total wages earned on the days when full time work was done during a period of three months immediately preceding the date of such miscarriage.</p> <p>3. Conditions for the grant of Maternity Leave: No maternity leave benefit shall be admissible to a woman unless she has been employed for a total period of not less than six months immediately preceding the date on which she proceeds on leave.</p> <p>4. The contractor shall maintain a register of Maternity (Benefit) in the form prescribed by Engineer-in-charge and the same shall be kept at the place of work.</p>
	<p><b>CLAUSE 19 G</b></p> <p>In the event of the contractor(s) committing a default or breach of any of the provisions of</p>

the Contractor's Labour Regulations and Model Rules for the protection of health and sanitary arrangements for the workers as amended from time to time or furnishing any information or submitting or filing any statement under the provisions of the relevant Regulations and Rules which is materially incorrect, he/they shall, without prejudice to any other liability, pay to U.P. Jal Nigam a sum as decided by the authority mentioned in **Schedule F** per day of default, breach or furnishing, making, submitting, filing such materially incorrect statements and in the event of the contractor(s) defaulting continuously in this respect, the penalty may be enhanced to as decided by the authority mentioned in **Schedule F** for each day of default subject to a maximum of 5 per cent of the contracted amount. The decision of the Engineer-in-Charge shall be final and binding on the parties.

Should it appear to the Engineer-in-Charge that the contractor(s) is/are not properly observing and complying with the provisions of the Contractor's Labour Regulations and Model Rules and the provisions of the Contract Labour (Regulation and Abolition) Act 1970, and the Contract Labour (R& A) Central Rules 1971, for the protection of health and sanitary arrangements for work-people employed by the contractor(s) (hereinafter referred as "the said Rules") the Engineer-in-Charge shall have power to give notice in writing to the contractor(s) requiring that the said Rules be complied with and the amenities prescribed therein be provided to the work-people within a reasonable time to be specified in the notice. If the contractor(s) shall fail within the period specified in the notice to comply with and/observe the said Rules and to provide the amenities to the work-people as aforesaid, the Engineer-in-Charge shall have the power to provide the amenities hereinbefore mentioned at the cost of the contractor(s). The contractor(s) shall erect, make and maintain at his/their own expense and to approved standards all necessary huts and sanitary arrangements required for his/their work-people on the site in connection with the execution of the works, and if the same shall not have been erected or constructed, according to approved standards, the Engineer-in-Charge shall have power to give notice in writing to the contractor(s) requiring that the said huts and sanitary arrangements be remodelled and/or reconstructed according to approved standards, and if the contractor(s) shall fail to remodel or reconstruct such huts and sanitary arrangements according to approved standards within the period specified in the notice, the Engineer-in-Charge shall have the power to remodel or reconstruct such huts and sanitary arrangements according to approved standards at the cost of the contractor(s).

#### **CLAUSE 19 H**

The contractor(s) shall at his/their own cost provide his/their labour with a sufficient number of huts (hereinafter referred to as the camp) of the following specifications on a suitable plot of land to be approved by the Engineer-in-Charge.

- (i) (a) The minimum height of each hut at the eaves level shall be 2.10m (7 ft.) and the floor area to be provided will be at the rate of 2.7 sq.m. (30 sq.ft.) for each member of the worker's family staying with the labourer.
- (b) The contractor(s) shall in addition construct suitable cooking places having a minimum area of 1.80m x 1.50m (6'x5') adjacent to the hut for each family.
- (c) The contractor(s) shall also construct temporary latrines and urinals for the use of the labourers each on the scale of not less than four per each one hundred of the total strength, separate latrines and urinals being provided for women.

	<p>(d) The contractor(s) shall construct sufficient number of bathing and washing places, one unit for every 25 persons residing in the camp. These bathing and washing places shall be suitably screened.</p> <p>(ii) (a) All the huts shall have walls of sun-dried or burnt-bricks laid in mud mortar or other suitable local materials as may be approved by the Engineer-in-Charge. In case of sun-dried bricks, the walls should be plastered with mud gobri on both sides. The floor may be kutcha but plastered with mud gobri and shall be at least 15 cm (6") above the surrounding ground. The roofs shall be laid with thatch or any other materials as may be approved by the Engineer-in-Charge and the contractor shall ensure that throughout the period of their occupation, the roofs remain water-tight.</p> <p>(b) The contractor(s) shall provide each hut with proper ventilation.</p> <p>(c) All doors, windows, and ventilators shall be provided with suitable leaves for security purposes.</p> <p>(d) There shall be kept an open space of at least 7.2m (8 yards) between the rows of huts which may be reduced to 6m (20 ft.) according to the availability of site with the approval of the Engineer-in-Charge. Back-to-back construction will be allowed.</p> <p>(iii) <b>Water Supply</b> - The contractor(s) shall provide adequate supply of water for the use of labourers. The provisions shall not be less than two gallons of pure and wholesome water per head per day for drinking purposes and three gallons of clean water per head per day for bathing and washing purposes. Where piped water supply is available, supply shall be at stand posts and where the supply is from wells or river, tanks which may be of metal or masonry, shall be provided. The contractor(s) shall also at his/ their own cost make arrangements for laying pipe lines for water supply to his/ their labour camp from the existing mains wherever available, and shall pay all fees and charges therefore.</p> <p>(iv) The site selected for the camp shall be high ground, removed from jungle.</p> <p>(v) <b>Disposal of Excreta</b> - The contractor(s) shall make necessary arrangements for the disposal of excreta from the latrines by trenching or incineration which shall be according to the requirements laid down by the Local Health Authorities. If trenching or incineration is not allowed, the contractor(s) shall make arrangements for the removal of the excreta through the Municipal Committee/authority and inform it about the number of labourers employed so that arrangements may be made by such Committee/authority for the removal of the excreta. All charges on this account shall be borne by the contractor and paid direct by him to the Municipality/authority. The contractor shall provide one sweeper for every eight seats in case of dry system.</p> <p>(vi) <b>Drainage</b> - The contractor(s) shall provide efficient arrangements for draining away sullage water so as to keep the camp neat and tidy.</p> <p>(vii) The contractor(s) shall make necessary arrangements for keeping the camp area sufficiently lighted to avoid accidents to the workers.</p> <p>(viii) <b>Sanitation</b> - The contractor(s) shall make arrangements for conservancy and</p>
--	--

	<p>sanitation in the labour camps according to the rules of the Local Public Health and Medical Authorities.</p>
	<p><b>CLAUSE 19 I</b></p> <p>The Engineer-in-Charge may require the contractor to dismiss or remove from the site of the work any person or persons in the contractors' employment upon the work who may be incompetent or misconduct himself and the contractor shall forthwith comply with such requirements. In respect of maintenance/repair or renovation works etc. where the labour have an easy access to the individual houses, the contractor shall issue identity cards to the labourers, whether temporary or permanent and he shall be responsible for any untoward action on the part of such labour. Resident Engineer will display a list of contractors working in the colony/Blocks on the notice board in the colony and also at the service centre, to apprise the residents about the same.</p> <p><b>CLAUSE 19J</b></p> <p>It shall be the responsibility of the contractor to see that the structure/building under construction is not occupied by anybody unauthorizedly during construction, and is handed over with vacant possession of complete building. If such building though completed is occupied illegally, then the Engineer-in-Charge shall have the option to refuse to accept the said structures/building/buildings in that position. Any delay in acceptance on this account will be treated as the delay in completion and for such delay, a levy upto 5% of contract amount as may be imposed by the competent authority whose decision shall be final both with regard to the justification and quantum and be binding on the contractor.</p> <p>However, the Engineer-in-Charge, through a notice, may require the contractor to remove the illegal occupation any time on or before construction and delivery.</p>
<p><b>Employment of skilled/semi skilled workers</b></p>	<p><b>CLAUSE 19K</b></p> <p>The contractor shall, at all stages of work, deploy skilled/semi-skilled tradesmen who are qualified and possess relevant certificates in particular trade from Industrial Training Institute/National Institute of construction Management and Research (NICMAR)/ National Academy of Construction, CIDC or any similar reputed and recognized Institute managed/ certified by State/Central U.P. Jal Nigam. The number of such qualified tradesmen shall not be less than 20% of total skilled/semi-skilled workers required in each trade at any stage of work.</p> <p>The contractor shall submit number of man days required in respect of each trade, its scheduling and the list of qualified tradesmen along with requisite certificate from recognized Institute to Engineer-in-Charge for approval. Notwithstanding such approval, if the tradesmen are found to have inadequate skill to execute the work of respective trade, the contractor shall substitute such tradesmen within two days of written notice from Engineer-in-Charge. Failure on the part of contractor to obtain approval of Engineer-in-Charge or failure to deploy qualified tradesmen will attract a compensation to be paid by contractor at the rate as may be decided by the authority mentioned in <b>Schedule F</b> per such tradesman per day. Decision of Engineer-in-Charge as to whether particular tradesman possesses requisite skill and amount of compensation in case of default shall be final and binding.</p>

	<p>Provided always, that the provisions of this clause, shall not be applicable for works with estimated cost put to tender being less than Rs. 10 crores.</p>
<p><b>Minimum Wages Act to be Complied with</b></p>	<p><b>CLAUSE 20</b></p> <p>The contractor shall comply with all the provisions of the Minimum Wages Act, 1948, and Contract Labour (Regulation and Abolition) Act, 1970, amended from time to time and rules framed thereunder and other labour laws affecting contract labour that may be brought into force from time to time.</p>
<p><b>Work not to be sublet. Action in case of insolvency</b></p>	<p><b>CLAUSE 21</b></p> <p>The contract shall not be assigned or sublet without the written approval of the NIT approving authority. And if the contractor shall assign or sublet his contract, or attempt to do so, or become insolvent or commence any insolvency proceedings or make any composition with his creditors or attempt to do so, or if any bribe, gratuity, gift, loan, perquisite, reward or advantage pecuniary or otherwise, shall either directly or indirectly, be given, promised or offered by the contractor, or any of his servants or agent to any public officer or person in the employ of U.P. Jal Nigam in any way relating to his office or employment, or if any such officer or person shall become in any way directly or indirectly interested in the contract, the Engineer- in-Charge on behalf of U.P. Jal Nigam shall have power to adopt the course specified in Clause 3 hereof in the interest of Government and in the event of such course being adopted, the consequences specified in the said Clause 3 shall ensue.</p> <p><b>CLAUSE 22</b></p> <p>All sums payable by way of compensation under any of these conditions shall be considered as reasonable compensation to be applied to the use of U.P. Jal Nigam without reference to the actual loss or damage sustained and whether or not any damage shall have been sustained.</p>
<p><b>Changes in firm's Constitution to be intimated</b></p>	<p><b>CLAUSE 23</b></p> <p>Where the contractor is a partnership firm, the previous approval in writing of the tender approving authority shall be obtained before any change is made in the constitution of the firm. Where the contractor is an individual or a Hindu undivided family business concern, such approval as aforesaid shall likewise be obtained before the contractor enters into any partnership agreement where under the partnership firm would have the right to carry out the works hereby undertaken by the contractor. If previous approval as aforesaid is not obtained, the contract shall be deemed to have been assigned in contravention of Clause 21 hereof and the same action may be taken, and the same consequences shall ensue as provided in the said Clause 21.</p> <p><b>CLAUSE 24</b></p> <p>All works to be executed under the contract shall be executed under the direction and subject to the approval in all respects of the Engineer-in-Charge who shall be entitled to direct at what point or points and in what manner they are to be commenced, and from time to time carried on.</p>

<p><b>Life Cycle Cost</b></p>	<p><b>CLAUSE 24</b></p> <p>The contractor shall be responsible for safety, quality and soundness of the structures/buildings including their structural elements beyond maintenance period. The contractor shall have obligation to rectify such defects minimum up to 5 (five) years from the date of completion of work. The defects have to be rectified within a reasonable time not exceeding three months after issue of notice by Engineer- in- Charge.</p>
<p><b>Settlement of Disputes &amp; Arbitration</b></p>	<p><b>CLAUSE 25</b></p> <p>Except where otherwise provided in the contract, all questions and disputes relating to the meaning of the specifications, design, drawings and instructions here-in before mentioned and as to the quality of workmanship or materials used on the work or as to any other question, claim, right, matter or thing whatsoever in any way arising out of or relating to the contract, designs, drawings, specifications, estimates, instructions, orders or these conditions or otherwise concerning the works or the execution or failure to execute the same whether arising during the progress of the work or after the cancellation, termination, completion or abandonment thereof shall be dealt with as mentioned hereinafter:</p> <p>(i) If the contractor considers any work demanded of him to be outside the requirements of the contract, or dispute any drawings, record or decision given in writing by the Engineer-in-Charge on any matter in connection with or arising out of the contract or carrying out of the contract or carrying out of the work, to be unacceptable, he shall promptly within 7 days request the Superintending Engineer in writing for written instruction of decision. Thereupon, the Superintending Engineer shall give his written instructions of decision within a period of fifteen days from the receipt of the contractor's letter. If the Superintending Engineer fails to give his instructions or decision in writing within the aforesaid period or if the contractor is dissatisfied with the instructions or decision of the Superintending Engineer, the contractor may, within 15 days of the receipt of Superintending Engineer's decision, appeal to the Chief Engineer who shall accord an opportunity to the contractor to be heard, if the later so desires, and to offer evidence in support of his appeal. The contractor shall not be represented by an advocate or legal counsel.</p> <p>The Chief Engineer shall give his decision within 30 days of receipt of contractor's appeal. If the contractor is dissatisfied with this decision, the contractor shall within a period of 30 days from receipt of the decision, give notice to the Chief Engineer for appointment of arbitrator failing which the said decision shall be final binding and conclusive and not referable to adjudication by the arbitrator.</p> <p>It is a term of contract that each party invoking arbitration must exhaust the aforesaid mechanism of settlement of claims/disputes prior to invoking arbitration.</p> <p>(ii) Except where the decision has become final, binding and conclusive in terms of Sub Para (i) above disputes or difference shall be referred for adjudication through arbitrator appointed by Managing Director, U P Jal Nigam. If the arbitrator so appointed is unable or unwilling to act or resign his appointment or vacates his office due to any reason whatsoever another sole arbitrator shall be appointed in the manner aforesaid. Such person shall be entitled to proceed with the reference</p>

	<p>from the stage at which it was left by his predecessor.</p> <p>It is a term of this contract that the party invoking arbitration shall give a list of disputes with amounts claimed in respect of each such dispute along with the notice for appointment of arbitrator and giving reference to the rejection by the Chief Engineer of the appeal.</p> <p>It is also a term of this contract that no person other than a person appointed by such Managing Director as aforesaid should act as arbitrator and if for any reason that is not possible, the matter shall not be referred to arbitrator at all. It is also a term of this contract that if the contractor does not make any demand for appointment of arbitrator in respect of any claims in writing as aforesaid within 45 days of receiving the intimation from the Engineer-in-Charge that the final bill is ready for payment, the claim of the contractor shall be deemed to have been waived and absolutely barred and U.P. Jal Nigam shall be discharged and released of all liabilities under the contract in respect of these claims.</p> <p>The arbitration shall be conducted in accordance with the provisions of the Arbitration and Conciliation Act, 1996 (26 of 1996) or any statutory modifications or re-enactment thereof and the rules made there under and for the time being in force shall apply to the arbitration proceeding under this clause.</p> <p>Parties, before or at the time of appointment of Arbitral Tribunal may agree in writing for fast-track arbitration as per the Arbitration and Conciliation Act, 1996 (26 of 1996) as amended in 2015.</p> <p>It is also a term of this contract that the member of the Arbitration Tribunal shall be a Graduate Engineer with experience in handling public works engineering contracts at a level not lower than Chief Engineer (Level-II), U P Jal Nigam. This shall be treated as a mandatory qualification to be appointed as arbitrator.</p> <p>It is also a term of the contract that if any fees are payable to the arbitrator these shall be paid equally by both the parties.</p> <p><b>It is also a term of the contract that the arbitrator shall be deemed to have entered on the</b> reference on the date he issues notice to both the parties calling them to submit their statement of claims and counter statement of claims. The venue of the arbitration shall be such place as may be fixed by the arbitrator in his sole discretion. The fees, if any, of the arbitrator shall, if required to be paid before the award is made and published, be paid half and half by each of the parties. The cost of the reference and of the award (including the fees, if any, of the arbitrator) shall be in the discretion of the arbitrator who may direct to any by whom and in what manner such costs or any part thereof shall be paid and fix or settle the amount of costs to be so paid.</p> <p>Where the total amount of the claims by any party exceeds Rs. 1,00,000/-, the arbitrator shall give reasons for the award.</p> <p>It is also a term of the contract that if any fees are payable to the arbitrator, these shall be paid as may be fixed by the Managing Director, U P Jal Nigam from time to time.</p> <p>The place of arbitration shall be as mentioned in <b>Schedule F</b>. In case there is no mention of place of arbitration, the arbitral tribunal shall determine the place of</p>
--	--

	<p>arbitration in consultation with Engineer-in-charge and contractor. The venue of the arbitration shall be such place as may be fixed by the Arbitral Tribunal in consultation with both the parties. Failing any such agreement, then the Arbitral Tribunal shall decide the venue.</p>
<p><b>Contractor to indemnify Govt. against Patent Rights</b></p>	<p><b>CLAUSE 26</b></p> <p>The contractor shall fully indemnify and keep indemnified U.P. Jal Nigam against any action, claim or proceeding relating to infringement or use of any patent or design or any alleged patent or design rights and shall pay any royalties which may be payable in respect of any article or part thereof included in the contract. In the event of any claims made under or action brought against U.P. Jal Nigam in respect of any such matters as aforesaid, the contractor shall be immediately notified thereof and the contractor shall be at liberty, at his own expense, to settle any dispute or to conduct any litigation that may arise therefrom, provided that the contractor shall not be liable to indemnify U.P. Jal Nigam if the infringement of the patent or design or any alleged patent or design right is the direct result of an order passed by the Engineer-in-Charge in this behalf.</p>
<p><b>Lumpsum Provisions in Tender</b></p>	<p><b>CLAUSE 27</b></p> <p>When the estimate on which a tender is made includes lump sum in respect of parts of the work, the contractor shall be entitled to payment in respect of the items of work involved or the part of the work in question at the same rates as are payable under this contract for such items, or if the part of the work in question is not, in the opinion of the Engineer-in-Charge payable of measurement, the Engineer-in-Charge may at his discretion pay the lump-sum amount entered in the estimate, and the certificate in writing of the Engineer-in-Charge shall be final and conclusive against the contractor with regard to any sum or sums payable to him under the provisions of the clause.</p>
<p><b>Action where no Specifications are specified</b></p>	<p><b>CLAUSE 28</b></p> <p>In the case of any class of work for which there is no such specifications as referred to in Clause 11, such work shall be carried out in accordance with relevant CPHEEO Manual as amended from time to time, UPJN/UPPWD/CPWD specifications, the Bureau of Indian Standards Specifications. In case, there are no such specifications in Bureau of Indian Standards, the work shall be carried out as per manufacturers' specifications, if not available then as per State/District Specifications. In case there are no such specifications as required above, the work shall be carried out in all respects in accordance with the instructions and requirements of the Engineer-in-Charge.</p>
<p><b>Withholding and lien in respect of sum due from contractor</b></p>	<p><b>CLAUSE 29</b></p> <p>(i) Whenever any claim or claims for payment of a sum of money arises out of or under the contract or against the contractor, the Engineer-in-Charge or U.P. Jal Nigam shall be entitled to withhold and also have a lien to retain such sum or sums in whole or in part from the security/additional security, if any deposited by the contractor and for the purpose aforesaid, the Engineer-in-Charge or U.P. Jal Nigam shall be entitled to withhold the security deposit, if any, furnished as the case may be and also have a lien over the same pending finalisation or adjudication of any such claim. In the event of the security being insufficient to cover the claimed amount or amounts or if no security has</p>

	<p>been taken from the contractor, the Engineer-in-Charge or U.P. Jal Nigam shall be entitled to withhold and have a lien to retain to the extent of such claimed amount or amounts referred to above, from any sum or sums found payable or which may at any time thereafter become payable to the contractor under the same contract or any other contract with the Engineer-in-Charge or U.P. Jal Nigam or any contracting person through the Engineer-in-Charge pending finalization of adjudication of any such claim.</p> <p>It is an agreed term of the contract that the sum of money or moneys so withheld or retained under the lien referred to above by the Engineer-in-Charge or U.P. Jal Nigam will be kept withheld or retained as such by the Engineer-in-Charge or U.P. Jal Nigam till the claim arising out of or under the contract is determined by the arbitrator (if the contract is governed by the arbitration clause) by the competent court, as the case may be and that the contractor will have no claim for interest or damages whatsoever on any account in respect of such withholding or retention under the lien referred to above and duly notified as such to the contractor. For the purpose of this clause, where the contractor is a partnership firm, joint venture or a limited company, the Engineer-in-Charge or U.P. Jal Nigam shall be entitled to withhold and also have a lien to retain towards such claimed amount or amounts in whole or in part from any sum found payable to any partner/limited company as the case may be, whether in his individual capacity or otherwise.</p> <p>(ii) U.P. Jal Nigam shall have the right to cause an audit and technical examination of the works and the final bills of the contractor including all supporting vouchers, abstract, etc., to be made after payment of the final bill and if as a result of such audit and technical examination any sum is found to have been overpaid in respect of any work done by the contractor under the contract or any work claimed to have been done by him under the contract and found not to have been executed, the contractor shall be liable to refund the amount of over-payment and it shall be lawful for U.P. Jal Nigam to recover the same from him in the manner prescribed in sub-clause (i) of this clause or in any other manner legally permissible; and if it is found that the contractor was paid less than what was due to him under the contract in respect of any work executed by him under it, the amount of such under payment shall be duly paid by U.P. Jal Nigam to the contractor, without any interest thereon whatsoever.</p> <p>Provided that U.P. Jal Nigam shall not be entitled to recover any sum overpaid, nor the contractor shall be entitled to payment of any sum paid short where such payment has been agreed upon between U.P. Jal Nigam on the one hand and the contractor on the other under any term of the contract permitting payment for work after assessment by U.P. Jal Nigam.</p>
<p><b>Lien in respect of claims in other Contracts</b></p>	<p><b>CLAUSE 29A</b></p> <p>Any sum of money due and payable to the contractor (including the security deposit returnable to him) under the contract may be withheld or retained by way of lien by the Engineer-in-Charge or U.P. Jal Nigam or any other contracting person or persons through Engineer-in-Charge against any claim of the Engineer-in-Charge or U.P. Jal Nigam or such other person or persons in respect of payment of a sum of money arising out of or under any other contract made by the contractor with the Engineer- in-Charge or U.P. Jal Nigam or with such other person or persons.</p>

	<p>It is an agreed term of the contract that the sum of money so withheld or retained under this clause by the Engineer-in-Charge or U.P. Jal Nigam will be kept withheld or retained as such by the Engineer-in-Charge or U.P. Jal Nigam or till his claim arising out of the same contract or any other contract is either mutually settled or determined by the arbitration clause or by the competent court, as the case may be and that the contractor shall have no claim for interest or damages whatsoever on this account or on any other ground in respect of any sum of money withheld or retained under this clause and duly notified as such to the contractor.</p>
<b>Unfiltered water supply</b>	<p><b>CLAUSE 30</b></p> <p>The contractor(s) shall make his/their own arrangements for water required for the work and nothing extra will be paid for the same. This will be subject to the following conditions.</p> <p>(i) That the water used by the contractor(s) shall be fit for construction purposes to the satisfaction of the Engineer-in-Charge.</p> <p>(ii) The Engineer-in-Charge shall make alternative arrangements for supply of water at the risk and cost of contractor(s) if the arrangements made by the contractor(s) for procurement of water are in the opinion of the Engineer-in-Charge, unsatisfactory.</p>
<b>Alternate Water Arrangement</b>	<p><b>CLAUSE 30A</b></p> <p>The contractor shall be allowed to construct temporary wells as may be chosen by the Engineer-in-charge for taking water for construction purposes only after he has got permission of the Engineer-in- Charge in writing. No charges shall be recovered from the contractor on this account, but the contractor shall be required to provide necessary safety arrangements to avoid any accidents or damage to adjacent buildings, roads and service lines. He shall be responsible for any accidents or damage caused due to construction and subsequent maintenance of the wells and shall restore the ground to its original condition after the wells are dismantled on completion of the work.</p>
<b>U.P. Jal Nigam water supply, if available</b>	<p><b>CLAUSE 30 B</b></p> <p>Water, if available, may be supplied to the contractor by U.P. Jal Nigam subject to the following conditions:-</p> <p>(i) The water charges @ 1 % shall be recovered on gross amount of the work done.</p> <p>(ii) The contractor(s) shall make his/their own arrangement of water connection and laying of pipelines from existing main of source of supply.</p> <p>(iii) U.P. Jal Nigam does not guarantee to maintain uninterrupted supply of water and it will be incumbent on the contractor(s) to make alternative arrangements for water at his/ their own cost in the event of any temporary break down in U.P. Jal Nigam water main so that the progress of his/their work is not held up for want of water. No claim of damage or refund of water charges will be entertained on account of such break down.</p>
<b>Hire of Plant and Machinery</b>	<p><b>CLAUSE 31</b></p> <p>The contractor shall arrange at his own expense all tools, plant, machinery and equipment (hereinafter referred to as T&amp;P) required for execution of the work.</p>

**Employment of  
Technical Staff  
and Employees**

**CLAUSE 32**

**Contractors Superintendence, Supervision, Technical Staff & Employees:**

(i) The contractor shall provide all necessary superintendence during execution of the work and all along thereafter as may be necessary for proper fulfilling of the obligations under the contract.

The contractor shall immediately after receiving letter of acceptance of the tender and before commencement of the work, intimate in writing to the Engineer-in-Charge, the name(s), qualifications, experience, age, address(s) and other particulars along with certificates, of the principal technical representative to be in charge of the work and other technical representative(s) who will be supervising the work. Minimum requirement of such technical representative(s) and their qualifications and experience shall not be lower than specified in **Schedule F**. Even if the contractor (or partner(s) in case of firm/ company) is himself / herself an Engineer, it is necessary on the part of the contractor to employ principal technical representative / technical representative (s) as per stipulation in **Schedule F**.

The Engineer-in-Charge shall within 3 days of receipt of such communication intimate in writing his approval or otherwise of such a representative(s) to the contractor. Any such approval may at any time be withdrawn and in case of such withdrawal, the contractor shall appoint another such representative(s) according to the provisions of this clause. Decision of the tender accepting authority shall be final and binding on the contractor in this respect. Such a principal technical representative and other technical representative(s) shall be appointed by the contractor soon after receipt of the approval from Engineer-in-charge and shall be available at site before start of work.

All the provisions applicable to the principal technical representative under the Clause will also be applicable to other technical representative(s). The principal technical representative and other technical representative(s) shall be present at the site of work for supervision at all times when any construction activity is in progress and also present himself/themselves, as required, to the Engineer-in-Charge and/or his designated representative to take instructions. Instructions given to the principal technical representative or other technical representative(s) shall be deemed to have the same force as if these have been given to the contractor. The principal technical representative and other technical representative(s) shall be actually available at site fully during all stages of execution of work, during recording/checking/test checking of measurements of works and whenever so required by the Engineer-in-Charge and shall also note down instructions conveyed by the Engineer-in-Charge or his designated representative(s) in the site order book and shall affix his/their signature in token of noting down the instructions and in token of acceptance of measurements/checked measurements/test checked measurements. The representative(s) shall not look after any other work. Substitutes, duly approved by Engineer-in-Charge of the work in similar manner as aforesaid shall be provided in event of absence of any of the representative(s) by more than two days.

	<p>If the Engineer-in-Charge, whose decision in this respect is final and binding on the contractor, is convinced that no such technical representative(s) is/are effectively appointed or is/are effectively attending or fulfilling the provision of this clause, a recovery (nonrefundable) shall be effected from the contractor as specified <b>in Schedule F</b> and the decision of the Engineer-In-Charge as recorded in the site order book and measurement recorded checked/test checked in Measurement Books shall be final and binding on the contractor. Further if the contractor fails to appoint suitable technical Principal technical representative and/or other technical representative(s) and if such appointed persons are not effectively present or are absent by more than two days without duly approved substitute or do not discharge their responsibilities satisfactorily, the Engineer-in-Charge shall have full powers to suspend the execution of the work until such date as suitable other technical representative(s) is/are appointed and the contractor shall be held responsible for the delay so caused to the work. The contractor shall produce evidence of appointment of technical representative if at any time so required by the Engineer-in-Charge.</p> <p>(ii) The contractor shall provide and employ on the site only such technical assistants as are skilled and experienced in their respective fields and such foremen and supervisory staff as are competent to give proper supervision to the work.</p> <p>The contractor shall provide and employ skilled, semiskilled and unskilled labour as is necessary for proper and timely execution of the work.</p> <p>The Engineer-in-Charge shall be at liberty to object to and require the contractor to remove from the works any person who in his opinion misconducts himself, or is incompetent or negligent in the performance of his duties or whose employment is otherwise considered by the Engineer-in-Charge to be undesirable. Such person shall not be employed again at works site without the written permission of the Engineer-in-Charge and the persons so removed shall be replaced as soon as possible by competent substitutes.</p> <p>Technical officers / staff deployed by the Contractor at any construction site will also be responsible for inferior quality/poor performance of any work and his name will be circulated to all works divisions of U.P. Jal Nigam to debar from any other site, if his name is being proposed by other contractors.</p>
<p><b>Levy/Taxes Payable by Contractor</b></p>	<p><b>CLAUSE 33</b></p> <p>(i) The rates quoted by the Contractor shall be exclusive of GST, but inclusive of all other taxes, levies, tolls, royalties, Labour Cess etc. The GST shall be paid by the contractor and U.P. Jal Nigam will reimburse GST so paid on actual basis. Building and other Construction Workers Welfare Cess or any other tax, levy or Cess in respect of input for or output by this contract shall be payable by the contractor and U.P. Jal Nigam shall not entertain any claim whatsoever in this respect except as <b>provided under Clause 34</b>.</p> <p>(ii) The contractor shall deposit royalty and obtain necessary permit for supply of the red bajri, stone, kankar, etc. from local authorities.</p> <p>If pursuant to or under any law, notification or order any royalty, cess or the like becomes payable by the Government of India and does not any time become payable by the contractor to the State Government, Local authorities in respect of any material used by the</p>

	contractor in the works, then in such a case, it shall be lawful to U.P. Jal Nigam and it will have the right and be entitled to recover the amount paid in the circumstances as aforesaid from dues of the contractor.
<b>Condition of Reimbursement of Levies/Taxes if Levied after receipt of Tenders</b>	<p><b>CLAUSE 34</b></p> <p>(i) All tendered rates shall be inclusive of any tax <b>(excluding GST)</b>, levy or cess applicable on last stipulated date of receipt of tender including extension if any. No adjustment i.e. increase or decrease shall be made for any variation in the rate of GST, Building and Other Construction Workers Welfare Cess or any tax, levy or cess applicable on inputs.</p> <p>However, effect of variation in rates of GST or Building and Other Construction Workers Welfare Cess or imposition or repeal of any other tax, levy or cess applicable on output of the works contract shall be adjusted on either side, increase or decrease.</p> <p>Provided further that for Building and Other Construction Workers Welfare Cess or any tax <b>(other than GST which will be reimbursed on actual basis)</b>, levy or cess varied or imposed after the last date of receipt of tender including extension if any, any increase shall be reimbursed to the contractor only if the contractor necessarily and properly pays such increased amount of taxes/levies/ cess.</p> <p>Provided further that such increase including GST shall not be made in the extended period of contract for which the contractor alone is responsible for delay as determined by authority for extension of time under Clause 5 in <b>Schedule F</b>.</p> <p>(ii) The contractor shall keep necessary books of accounts and other documents for the purpose of this condition as may be necessary and shall allow inspection of the same by a duly authorized representative of U.P. Jal Nigam and/or the Engineer-in-Charge and shall also furnish such other information/document as the Engineer-in-Charge may require from time to time.</p> <p>(iii) The contractor shall, within a period of 30 days of the imposition of any such further tax or levy or cess, give a written notice thereof to the Engineer-in-Charge that the same is given pursuant to this condition, together with all necessary information relating thereto.</p>
<b>Termination of Contract on death of contractor</b>	<p><b>CLAUSE 35</b></p> <p>Without prejudice to any of the rights or remedies under this contract, if the contractor dies, the Engineer-in-charge on behalf of U.P. Jal Nigam shall have the option of terminating the contract without compensation to the contractor.</p>
<b>If relative working in U.P. Jal Nigam then the contractor not allowed to tender</b>	<p><b>CLAUSE 36</b></p> <p>The contractor shall not be permitted to tender for works in the jurisdiction of Superintending Engineer responsible for execution of contracts in which his near relative is posted as Accountant or as an officer in any capacity between the grades of the Superintending Engineer and Junior Engineer (both inclusive). He shall also intimate the names of persons who are working with him in any capacity or are subsequently employed by him and who are near relatives to any Officer in U P Jal Nigam. Any breach of this</p>

	<p>condition by the contractor would render him liable to be debarred from tendering in for any breach of this condition.</p> <p><b>NOTE:</b> By the term “near relatives” is meant wife, husband, parents and grandparents, children and grandchildren, brothers and sisters, uncles, aunts and cousins and their corresponding in-laws.</p>
<p><b>No Gazetted Engineer to work as Contractor within one year of retirement</b></p>	<p><b>CLAUSE 37</b></p> <p>No engineer of gazetted rank (Category „A“ and „B“) or other gazetted officer employed in engineering or administrative duties in an engineering department of the Government-State or Central shall work as a contractor or employee of a contractor for a period of one year after his retirement from Government service without the previous permission of Government in writing. This contract is liable to be cancelled if either the contractor or any of his employees is found at any time to be such a person who had not obtained the permission of Government as aforesaid, before submission of the tender or engagement in the contractor’s service, as the case may be.</p>
<p><b>Theoretical Consumption of Materials</b></p>	<p><b>CLAUSE 38</b></p> <p>(i) After completion of the work and also at any intermediate stage in the event of non (reconciliation of materials issued, consumed and in balance - (see Clause 10), theoretical quantity of materials issued by U.P. Jal Nigam for use in the work shall be calculated on the basis and method given hereunder:-</p> <p>(a) Quantity of cement shall be calculated on the basis of quantity of cement required for different items of work as shown in the Schedule of Rates mentioned in <b>Schedule „F“</b>. In case any item is executed for which standard constants for the consumption of cement or bitumen are not available in the above-mentioned schedule/statement or cannot be derived from the same shall be calculated on the basis of standard formula to be laid down by the Engineer-in-Charge.</p> <p>(b) Theoretical quantity of steel reinforcement or structural steel sections shall be taken as the quantity required as per design or as authorized by Engineer-in-Charge, including authorized lappages, chairs etc. plus 3% wastage due to cutting into pieces, such theoretical quantity being determined and compared with the actual issues each diameter wise, section wise and category wise separately.</p> <p>(c) For any other material as per actual requirements.</p> <p>(ii) Over the theoretical quantities of materials so computed a variation shall be allowed as specified in <b>Schedule F</b>. The difference in the net quantities of material actually issued to the contractor and the theoretical quantities including such authorized variation, if not returned by the contractor or if not fully reconciled to the satisfaction of the Engineer-in-Charge within fifteen days of the issue of written notice by the Engineer-in-Charge to this effect, shall be recovered at the rates specified in <b>Schedule F</b>, without prejudice to the provision of the relevant conditions regarding return of materials governing the contract. Decision of Engineer-in-Charge in regard to theoretical quantities of materials, which should have been actually used as per the Annexure of the standard schedule of rates and recovery at rates specified in <b>Schedule F</b>, shall be final &amp; binding on the contractor.</p>

	(iii) The said action under this clause is without prejudice to the right of U.P. Jal Nigam to take action against the contractor under any other conditions of contract for not doing the work according to the prescribed specifications.
<b>Compensation during warlike situations</b>	<b>CLAUSE 39</b> Deleted
<b>Apprentices Act provisions to be complied with</b>	<b>CLAUSE 40</b> The contractor shall comply with the provisions of the Apprentices Act, 1961 and the rules and orders issued thereunder from time to time. If he fails to do so, his failure will be a breach of the contract and the competent authority may, in his discretion, cancel the contract. The contractor shall also be liable for any pecuniary liability arising on account of any violation by him of the provisions of the said Act.
<b>Release of Security deposit after labour clearance</b>	<b>CLAUSE 41</b> Release of Security Deposit of the work shall not be done till the contractor produces a clearance certificate from the Labour Officer. As soon as the work is virtually complete, the contractor shall apply for the clearance certificate to the Labour Officer under intimation to the Engineer-in-Charge. The Engineer-in-Charge, on receipt of the said communication, shall write to the Labour Officer to intimate if any complaint is pending against the contractor in respect of the work. If no complaint is pending, on record till after 3 months after completion of the work and/or no communication is received from the Labour Officer to this effect till six months after the date of completion, it will be deemed to have received the clearance certificate and the Security Deposit will be released if otherwise due.
<b>Return of Surplus materials</b>	<b>CLAUSE 42</b> Notwithstanding anything contained to the contrary in this contract, where any materials for the execution of the contract are procured with the assistance of U.P. Jal Nigam either by issue from U.P. Jal Nigam stocks or purchase made under orders or permits or licences issued by Government/U.P. Jal Nigam, the contractor shall hold the said materials economically and solely for the purpose of the contract and not dispose of them without the written permission of U.P. Jal Nigam and return, if required by the Engineer-in-Charge, all surplus or unserviceable materials that may be left with him after the completion of the contract or at its termination for any reason whatsoever on being paid or credited such price as the Engineer-in-Charge shall determine having due regard to the condition of the materials. The price allowed to the contractor however shall not exceed the amount charged to him excluding the element of storage charges. The decision of the Engineer-in-Charge shall be final and conclusive. In the event of breach of the aforesaid condition, the contractor shall in addition to throwing himself open to action for contravention of the terms of the licence or permit and/or for criminal breach of trust, be liable to U.P. Jal Nigam for all moneys, advantages or profits resulting or which in the usual course would have resulted to him by reason of such breach.

<p><b>Condition relating to use of asphaltic materials</b></p>	<p><b>CLAUSE 43</b></p> <p>(i) The contractor undertakes to make arrangement for the supervision of the work by the firm supplying the tar or bitumen used.</p> <p>(ii) The contractor shall collect the total quantity of tar or bitumen required for the work as per standard formula, before the process of painting is started and shall hypothecate it to the Engineer-in-Charge. If any bitumen or tar remains unused on completion of the work on account of lesser use of materials in actual execution for reasons other than authorized changes of specifications and abandonment of portion of work, a corresponding deduction equivalent to the cost of unused materials as determined by the Engineer-in-Charge shall be made and the material return to the contractors. Although the materials are hypothecated to U.P. Jal Nigam, the contractor undertakes the responsibility for their proper watch, safe custody and protection against all risks. The materials shall not be removed from site of work without the consent of the Engineer-in-Charge in writing.</p> <p>(iii) The contractor shall be responsible for rectifying defects noticed within a year from the date of handing over of the work and the portion of the security deposit relating to asphaltic work shall be refunded after the expiry of this period.</p>
<p><b>Insurance</b></p>	<p><b>CLAUSE 44</b></p> <p>The Contractor shall provide, in the joint names of the Engineer-in-Charge and the Contractor, insurance cover from the Start Date to the end of the Defects Liability Period, in the amounts and deductibles stated in the <b>Schedule F</b> for the following events which are due to the Contractor's risks:</p> <p>(a) loss of or damage to the Works, Plant and Materials;</p> <p>(b) loss of or damage to Equipment;</p> <p>(c) loss of or damage of property (except the Works, Plant, Materials and Equipment) in connection with the Contract; and</p> <p>(d) personal injury or death.</p> <p>All such insurance shall provide for compensation to be payable in the types and proportions of currencies required to rectify the loss or damage incurred.</p>
<p><b>Safety Security and Protection of Environment</b></p>	<p><b>CLAUSE 45</b></p> <p>The Contractor shall, throughout the execution and completion of the Works and the remedying of any defects therein:</p> <p>(a) have full regard for the safety of all persons entitled to be upon the Site and keep the Site (so far as the same is under his control) and the Works (so far as the same are not completed or occupied by U.P. Jal Nigam) in an orderly state appropriate to the avoidance of danger to such persons.</p> <p>(b) Provide and maintain at his own cost all lights, guards, fencing, warning signs and watchmen and where necessary or required by the Engineer or by any duly constituted authority, for the protection of the Works or for the safety and convenience of the public or others, and</p> <p>(c) take all reasonable steps to protect the environment on and off the Site and to avoid damage or nuisance to persons or to property of the public or others resulting from pollution, noise or other causes arising as a consequence of his methods of operation.</p>

## **Appendix to Part I**

### **General Condition of Contract**

#### **SALIENT FEATURES OF SOME MAJOR LABOUR LAWS APPLICABLE TO ESTABLISHMENTS ENGAGED IN BUILDING AND OTHER CONSTRUCTION WORK.**

- a) Workmen Compensation Act 1923: - The Act provides for compensation in case of injury by accident arising out of and during the course of employment.
- b) Payment of Gratuity Act 1972: - Gratuity is payable to an employee under the Act on satisfaction of certain conditions on separation if an employee has completed the prescribed minimum years (say, five years) of service or more or on death the rate of prescribed minimum days (say, 15 days) wages for every completed year of service. The Act is applicable to all establishments employing the prescribed minimum number (say, 10) or more employees.
- c) Employees P.F. and Miscellaneous Provision Act 1952: The Act Provides for monthly contributions by the Employer plus workers at the rate prescribed (say, 10% or 8.33%). The benefits payable under the Act are:
- i. Pension or family pension on retirement or death as the case may be.
  - ii. Deposit linked insurance on the death in harness of the worker.
  - iii. Payment of P.F. accumulation on retirement/death etc.
- d) Maternity Benefit Act 1951: - The Act provides for leave and some other benefits to women employees in case of confinement or miscarriage etc.
- e) Contract Labour (Regulation & Abolition) Act 1970: - The Act provides for certain welfare measures to be provided by the Contractor to contract labour and in case the Contractor fails to provide, the same are required to be provided, by the Principal Employer by Law. The principal Employer is required to take Certificate of Registration and the Contractor is required to take license from the designated Officer. The Act is applicable to the establishments or Contractor of Principal Employer if they employ prescribed minimum (say 20) or more contract labour.
- f) Minimum Wages Act 1948: - The Employer is to pay not less than the Minimum Wages fixed by appropriate U.P. Jal Nigam as per provisions of the Act if the employment is a scheduled employment. Construction of buildings, roads, runways is scheduled employment.
- g) Payment of Wages Act 1936: - It lays down as to by what date the wages are to be paid, when it will be paid and what deductions can be made from the wages of the workers.
- h) Equal Remuneration Act 1979: - The Act provides for payment of equal wages for work of equal nature to male and female workers and for not making discrimination against female employees in the matters of transfers, training and promotions etc.
- i) Payment of Bonus Act 1965: - The Act is applicable to all establishments employing prescribed minimum (say, 20) or more workmen. The Act provides for payments of annual bonus within the prescribed range of percentage of wages to employees drawing up to the prescribed amount of wages, calculated in the prescribed manner. The Act does not apply to certain establishments. The newly set-up establishments are exempted for five years in certain circumstances. States may have different number of employment size.
- j) Industrial Disputes Act 1947: - The Act lays down the machinery and procedure for resolution of industrial disputes, in what situations a strike or lock-out becomes illegal and what are the requirements for laying off or retrenching the employees or closing down the establishment.

k) Industrial Employment (Standing Orders) Act 1946: - It is applicable to all establishments employing prescribed minimum (say, 100, or 50). The Act provides for laying down rules governing the conditions of employment by the Employer on matters provided in the Act and get these certified by the designated Authority.

l) Trade Unions Act 1926: - The Act lays down the procedure for registration of trade unions of workmen and Employers. The Trade Unions registered under the Act have been given certain immunities from civil and criminal liabilities.

m) Child Labour (Prohibition & Regulation) Act 1986: - The Act prohibits employment of children below 14 years of age in certain occupations and processes and provides for regulations of employment of children in all other occupations and processes. Employment of child labour is prohibited in building and construction industry.

n) Inter-State Migrant Workmen's (Regulation of Employment & Conditions of Service) Act 1979: - The Act is applicable to an establishment which employs prescribed minimum (say, five) or more inter-state migrant workmen through an intermediary (who has recruited workmen in one state for employment in the establishment situated in another state). The Inter-State migrant workmen, in an establishment to which this Act becomes applicable, are required to be provided certain facilities such as Housing, Medical-Aid, Travelling expenses from home up to the establishment and back etc.

o) The Building and Other Construction workers (Regulation of Employment and Conditions of Service) Act 1996 and the Cess Act of 1996: - All the establishments who carry on any building or other construction work and employs the prescribed minimum (say, 10) or more workers are covered under this Act. All such establishments are required to pay cess at the rate not exceeding 2% of the cost of construction as may be modified by U.P. Jal Nigam (Urban). The Employer of the establishment is required to provide safety measures at the building or construction work and other welfare measures, such as canteens, first-aid facilities, ambulance, housing accommodations for workers near the work place etc. The Employer to whom the Act applies has to obtain a registration certificate from the Registering Officer appointed by U.P. Jal Nigam (Urban).

p) Factories Act 1948: - The Act lays down the procedure for approval of plans before setting up a factory, health and safety provisions, welfare provisions, working hours, annual earned leave and rendering information regarding accidents or dangerous occurrences to designated authorities. It is applicable to premises employing the prescribed minimum (say, 10) persons or more with aid of power or another prescribed minimum (say, 20) or more persons without the aid of power engaged in manufacturing process.

q) Arbitration and Conciliation Act, 1996: - The Act lays down the procedure for appointment of Arbitrator, Arbitration and conciliation, Jurisdiction of Arbitral Tribunals, Recourse against Arbitral award appeals.

**SECTION – 4**

**PART-II**

**CONDITIONS OF CONTRACT**

**(SPECIAL CONDITIONS OF CONTRACT)**

# **SPECIAL CONDITIONS OF CONTRACT**

## **(A) GENERAL**

1. The contractor shall submit the time and progress chart and progress report using the mutually agreed software or in other format decided by Engineer-in-Charge for the work done during previous month to the Engineer-in-Charge on or before fifth day of each month failing which a recovery shall be made in case of delay in submission of the monthly progress report.
  - 1.1 Project information, giving the broad features of the work under the contract, and the broad structural as well as architectural and other details
  - 1.2 Introduction, giving a brief scope of the work under the contract, and the broad structural or other details.
  - 1.3 Construction schedule of the various components of the work through a bar chart for the next threequarters (or as may be specified), showing the milestones, targeted tasks and up to date progress
  - 1.4 Progress chart of the various components of the work that are planned and achieved, for the month as well as cumulative up to the month, with reasons for deviations, if any, in a tabular format.
  - 1.5 Plant and machinery statement, indicating those deployed in the work, and their workingstatus.
  - 1.6 Man-power statement, indicating individually the names of all the staff deployed in the work, along with their designations.
  - 1.7 Financial statement, indicating the broad details of all the running account payments received up to date, such as gross value of work done, advances taken recoveries effected, amounts withheld, net payments, details of cheque payments received, etc.
  - 1.8 A statement showing the extra and substituted items submitted by the contractor, and the payments received against them, items pending for sanction/decision by U.P. Jal Nigam, broad details of the Bank Guarantees, indicating clearly their validity periods, broad details of the insurance policies taken by the contractor, if any, the advances received and adjusted.
  - 1.9 Progress photographs, in colour, of the various items/components of the work done up to date, to indicate visually the actual progress of the work. Quality assurance and quality control tests conducted during the month, with the results thereof.
  - 1.10 Videography at various stages of construction right from the day of start of work to date of completion/occupation, covering all major events, inspections, visits by dignitaries etc.

## **2. INTERPRETING SPECIFICATIONS:**

In interpreting the specifications, the following order of decreasing importance shall be followed in case of contradictions:

- a. Nomenclature of items given in the Bill of quantities in the tender.
- b. Specifications
- c. Special conditions
- d. Contract & Clauses as per General Conditions of Contract.
- e. UPJN/PWD/C.P.W.D. Specifications as mentioned in clause 11 under schedule 'F' and MORTH Specifications with upto-date correction slips.
- f. Relevant I.S. Codes or specification.
- g. Directions of Engineer-in-charge shall be applicable where none of the above is to be applied

## **3. RATES:**

- 3.1 Unless otherwise provided in the Bill of quantities the rate tendered by the contractor shall be all inclusive and shall apply to all heights, lifts, leads and depths to the building and nothings extra shall be payable to him on this account.

- 3.2 Unless otherwise specified in the Bill of quantities, the rates for all items of work shall be considered as inclusive of pumping out or bailing out of water, if required for which no extra payment will be made. This will include water encountered from any source such as rains, floods, sub soil water table being high and /or due to any other cause whatsoever.
- 3.3 The tenderer shall abide by the rules and regulations of GST or any other tax etc. Necessary deductions on account of taxes shall be made on the gross value of the work done from the bills of the contractor as per the provisions of above stated Acts. Necessary certificates, if required, for tax deduction at source shall be issued to the contractor by the Engineer in Charge. However acceptability of the certificate by the concerned authority shall not be responsibility of Engineer-in-charge. The decision of the Engineer-in- Charge regarding quantum of tax to be deducted at source shall be final and binding on the contractor.
- 3.4 The contractor shall comply with proper and legal orders and directions of the local or public authority of municipality and abide by the rules and regulations and pay all fees and charges which he may be liable. Quoted rates shall be considered inclusive of all such fees and charges.
- 3.5 The rates quoted by the Contractor are deemed to be inclusive of site clearance, setting out work, profile, setting lay out on ground, establishment of reference bench mark(s), installing various signage, taking spotlevels, survey with total station, construction of all safety and protection devices, compulsory use of helmet and safety shoes, and other appropriate safety gadgets by workers, imparting continuous training for all the workers, barriers, preparatory works, construction of clean, hygienic and well ventilated workers housings in sufficient numbers as per drawing supplied by Engineer-in-charge, working during monsoon or odd season, working beyond normal hours and any other unforeseen but essential incidental works required to complete this work. Nothing extra shall be payable on this account and no extension of time for completion of work shall be granted on these accounts.
- 3.6 All ancillary and incidental facilities required for execution of work like labour camp, stores, fabrication yard, offices for Contractor, watch and ward, temporary ramp required to be made for working at the basement level, temporary structure for plants and machineries, water storage tanks, installation and consumption charges of temporary electricity, telephone, water etc. required for execution of the work, liaison and pursuing for obtaining various No Objection Certificates, completion certificates from local bodies etc., protection works, testing facilities / laboratory at site of work, facilities for all field tests and for taking samples etc. during execution or any other activity which is necessary (for execution of work and as directed by Engineer-in-Charge), shall be deemed to be included in rates quoted by the Contractor, for various items in the schedule of quantities. Nothing extra shall be payable on these accounts. Before start of the work, the Contractor shall submit to the Engineer-in-Charge, a site / construction yard layout, specifying areas for construction, site office, positioning of machinery, material yard, cement & other storage, fabrication yard, site laboratory, water tank etc.
- 3.7 For completing the work in time, the Contractor might be required to work in two or more shifts (including night shifts). No claim whatsoever shall be entertained on this account, not with-standing the fact that the Contractor may have to pay extra amounts for any reason, to the labourers and other staff engaged directly or indirectly on the work according to the provisions of the labour and other statutory bodies regulations and the agreement entered upon by the Contractor with them.
- 3.8 All material shall only be brought at site as per programme finalized with the Engineer- in- Charge. Any pre-delivery of the material not required for immediate consumption shall not be accepted and thus not paid for.

#### **4. Electric Connection & Supply:**

- 4.1 The contractor shall make his own arrangements for obtaining electric connections, if required and make necessary payments directly to U.P. Jal Nigam (Urban) concerned.

- 4.2 U.P. Jal Nigam (Urban) shall in no way be responsible for either any delay in getting electric connection for execution of the work or not getting connection at all. No claim of any kind whatsoever on this account shall be entertained from the contractor.

**5. Co-operation & Co-ordination with other agencies:**

- 5.1 The contractor for this work shall plan his work in such a manner so that the work (s) of other contractor (s) is /are not affected in any way. The work should be planned in a systematic manner so as to ensure proper co-ordination of various disciplines viz. sanitary & water supply, drainage, rain water harvesting, electrical, fire fighting, information technology, communication & electronics and any other services.
- 5.2 Conduits for electrical wiring/cables will be laid in such a way that they leave enough space for Concreting and do not adversely affect the structural members. Nothing extra over the agreement rate shall be paid for the same.
- 5.3 The successful tenderer shall co-ordinate with other contractors and agencies engaged, if any, and exchange freely all technical information so as to make the execution of this works contract smooth. No remuneration should be claimed from U.P. Jal Nigam (Urban) for such technical cooperation. If any unreasonable hindrance is caused to other agencies and any completed portion of the work has to be dismantled and re-done for want of cooperation and coordination by the successful tenderer during the course of work, such expenditure incurred will be recovered from the successful tenderer if the restoration work to the original condition or specification of the dismantled portion of the work was not undertaken by the successful tenderer himself.
- 5.4 The Contractor shall take all necessary precautions to prevent any nuisance or inconvenience to the owners, tenants or occupants of the adjacent properties and to the public in general. The Contractor shall take all care, as not to damage any other adjacent property or other services running adjacent to the plot/alignment. If any damage is done, the same shall be made good by the Contractor at his own cost and to the entire satisfaction of the Engineer-in-Charge. The Contractor shall use such methodology and equipments for execution of the work, so as to cause minimum environmental pollution of any kind during construction. Further, the Contractor shall take all precautions to abide by the environmental related restrictions imposed by Pollution Control Board, of State/ honourable NGT.
- 5.5 Utmost care shall be taken to keep the noise level to the barest minimum so that no disturbance as far as possible is caused to the occupants / users of adjoining buildings. No claim what so ever on account of site constraints mentioned above or any other site constraints, inadequate availability of skilled, semi-skilled or unskilled workers in the near vicinity, non-availability of construction machinery spare parts and any other constraints not specifically stated here, shall be entertained from the Contractor.
- 5.6 The contractor shall conduct his work, so as not to interfere with or hinder the progress or completion of the work being performed by other contractor(s) or by the Engineer-in-Charge and shall as far as possible arrange his work and shall place and dispose off the materials being used or removed so as not to interfere with the operations of other contractors or he shall arrange his work with that of the others in an acceptable and in a proper co-ordinated manner and shall perform it in proper sequence to the complete satisfaction of others.

**6. Safety Measures :-**

- 6.1 The contractor shall also provide necessary barricade, informatory boards, lights and flagmen at either end of the execution area and at such intermediate points as required & as directed by the Engineer-in-charge at no extra cost.
- 6.2 The contractor shall maintain in good condition all work executed till the completion of the entire work entrusted to the contractor under this contract & nothing extra shall be paid on this account.
- 6.3 For form work use of solid timber and products involving solid timber shall not be permitted.

- 6.4 Any damage to work resulting from rains or from any other cause until the work is handed over by contractor after completion of work shall be made good by the contractor at his own cost.
- 6.5 Any damage made by men, machinery, vehicles (LMVs or HMTVs), or any way to the public/private property such as services of electricity, water, telephone, LAN, road and path during execution of the work shall be repaired/redone by the Agency/Contractor. If contractor fails to repair/redone damage, the work shall be done on his risk as per the direction of the Engineer in charge. No any cost claim shall be entertained on this account.
- 6.6 All safety equipment such as Safety Helmets, Safety shoes, gloves, Safety belt etc. shall be made available to site Engineers, Supervisors, labourers, masons fitters etc.

**7. Handling of Material/Waste :-**

- 7.1 Unserviceable materials shall have to be removed and disposed off to places as decided by the Engineer-in-charge. Scarified rubbish of brick aggregates of WBM etc. shall be spread on the shoulders / on the slope of embankments and suitably compacted for which nothing extra shall be paid.
- 7.2 The contractor shall take instructions from the Engineer-in-charge for stacking of materials in any place. Double handling of materials or excavated earth if required at any stage, shall have to be done by the contractor at his own cost. No excavated earth or building material shall be stacked on areas where other buildings, roads services of compound walls are to be constructed.
- 8. The contractor & his work people shall observe all relevant rules regarding security promulgated in which work is to be carried out by the controlling authority of the area.
- 9. In case of any calamity or injury to any labour/ workmen etc. or loss / wastage of materials due to nature or insurgency, contractor shall have to bear the cost of compensation and no claim to this effect shall be entertained by U.P. Jal Nigam.
- 10. The contractor shall keep himself ready for execution of any item / items of work / part of the item of work on emergent notice given by the Engineer-in-charge on day-to-day basis during rainy season at no extra cost.
- 11. The contractor shall give a performance test of the entire installation (s) as per standing specifications before the work is finally accepted and nothing extra whatsoever shall be payable to the contractor for the test.
- 12. Some restrictions may be imposed by the administration/ security staff etc. on the working and for movement of labour, materials etc. The contractor shall be bound to follow all such restriction / instructions including issue of identity cards to all persons authorized by him to do work / visit the work site and nothing shall be payable on this account.
- 13. No claim for idle establishment & labour, machinery & equipments, tools & plants and the like, for any reason whatsoever, shall be admissible during the execution of work as well as after its completion.
- 14. CLEANLINESS OF SITE:**
  - 14.1 The Contractor shall not stack building material /malba /muck/ rubbish on the land or road of the local development authority or on the land owned by the others, as the case may be. So the muck, rubbish etc. shall be removed periodically as directed by the Engineer-in-Charge, from the site of work to the approved dumping grounds as per the local byelaws and regulations of the concerned authorities and all necessary permissions in this regard from the local bodies shall be obtained by the Contractor.
  - 14.2 Nothing extra shall be payable on this account. In case, the Contractor is found stacking the building material / malba as stated above, the Contractor shall be liable to pay the stacking charges / penalty as maybe levied by the local body or any other authority and also to face penal action as per the rules, regulations and bye-laws of such body or authority. The Engineer –in-Charge shall be at liberty to recover, such sums due but not paid to the concerned authorities on the above counts, from any sums due to the Contractor including amount of the Security Deposit and performance guarantee in respect of this contract agreement.
- 14.3 CONDITIONS PRACTICES DURING CONSTRUCTION PHASE:**

- 14.3.1 The contractor shall specify and limit construction activity in pre-planned/designated areas and shall start construction work after securing the approval for the same from the Engineer-in-Charge. This shall include areas of construction, storage of materials, and material and personnel movement.
- 14.3.2 **Preserve and Protect Landscape during Construction:**
- a. The contractor shall ensure that no trees, existing or otherwise, shall be harmed and damage to roots. These shall be prevented during trenching, placing backfill, driving or parking heavy equipment, dumping of trash and protected from oil, paint, and other materials detrimental to plant health. These activities shall be restricted to the areas outside of the canopy of the tree, or, from a safe distance from the tree/plant by means of barricading. Trees will not be used for support; their trunks shall not be damaged by cutting and carving or by nailing posters, advertisements or other material. Lighting of fires or carrying out heat or gas emitting construction activity within the ground, covered by canopy of the tree is not at all permitted.
  - b. The contractor shall take steps to protect trees or saplings if any identified for preservation within the construction site using tree guards of approved specification.
  - c. The contractor shall avoid cut and fill in the root zones, through delineating and fencing the drip line (the spread limit of a canopy projected on the ground) of all the trees or group of trees. The zones of movement of heavy equipment, parking, or excessive foot traffic shall be separated from the fenced plant protection zones.
  - d. The contractor shall ensure that maintenance activities during construction period shall be performed as needed to ensure that the vegetation remains healthy.
- 14.3.3 Contractor shall be required to develop and implement a waste management plan, quantifying material diversion goals. He shall establish goals for diversion from disposal in landfills and incinerators, if required, and adopt a construction waste management plan to achieve these goals. A project wide policy of “Nothing leaves the Site” shall be followed.
- 14.3.4 Contractor shall collect all construction waste generated on site. He may consider at segregating wastes based on their utility and examine means of sending such waste to manufacturing units which use them as raw material or other site which require it for specific purpose. Typical construction debris could be broken bricks, steel bars, broken tiles, spilled concrete and mortar etc.
- 14.3.5 The contractor shall ensure cleanliness of workplace with regard to the disposal of waste and effluent; provide clean drinking water and latrines and urinals as per applicable provisions. Adequate toilet facilities shall be provided for the workmen within easy access of their place of work. The total no. to be provided shall not be less than 1 per 30 employees in any one shift. Toilet facilities shall be provided from the start of building operations, connection to a sewer shall be made as soon as practicable. Every toilet shall be so constructed that the occupant is sheltered from view and protected from the weather and falling objects. Toilet facilities shall be maintained in a sanitary condition. A sufficient quantity of disinfectant shall be provided and natural or artificial illumination shall also be provided.
- 14.3.6 The contractor shall ensure that air pollution due to dust/generators is kept to a minimum, preventing any adverse effects on the workers and other people in and around the site. The contractor shall ensure proper screening, covering stockpiles, covering brick and loads of dusty materials, wheel-washing facility, gravel pit, and water spraying. Contractor shall also ensure the following activities to prevent air pollution during construction:
- ✓ Clear vegetation only from areas where work will start right away.
  - ✓ Vegetate / mulch areas where vehicles do not ply.
  - ✓ Apply gravel / landscaping rock to the areas where mulching / paving is impractical.

- ✓ Identify roads on-site if applicable that would be used for vehicular traffic. Upgrade vehicular roads (if these are unpaved) by increasing the surface strength by improving particle size, shape and mineral types that make up the surface & base and add surface gravel to reduce source of dust emission to limit amount of fine particles (smaller than 0.075 mm) to 10 – 20%.
  - ✓ Water spray, through a simple hose for small projects, to keep dust under control. Fine mists should be used to control fine particulate. However, this should be done with care so as not to waste water. Heavy watering can also create mud, which when tracked onto paved public roadways, must be promptly removed. Also, there must be an adequate supply of clean water nearby to ensure that spray nozzles don't get plugged.
  - ✓ Water spraying shall be done on:
    - Any dusty materials before transferring, loading and unloading
    - Area where demolition work is being carried out
    - Any un-paved main haul road
    - Areas where excavation or earth moving activities are to be carried out.
  - ✓ The contractor shall ensure that the speed of vehicles within the site is limited to 10 km/hr.
  - ✓ All material storages should be adequately covered and contained so that they are not exposed to situations where winds on site could lead to dust / particulate emissions.
  - ✓ Spills of dirt or dusty materials will be cleaned up promptly so the spilled material does not become a source of fugitive dust and also to prevent of seepage of pollutant laden water into the ground aquifers. When cleaning up the spill, ensure that the clean-up process does not generate additional dust. Similarly, spilled concrete slurries or liquid wastes should be contained / cleaned up immediately before they can infiltrate into the soil / ground or runoff in nearby areas.
  - ✓ Provide hoardings of not less than 3m high along the site boundary, next to a road or other public area at his cost.
  - ✓ Provide dust screens, sheeting or netting to scaffold along the perimeter of the building at his cost.
  - ✓ Cover stockpiles of dusty material with impervious sheeting at his cost.
  - ✓ Cover dusty load on vehicles by impervious sheeting before they leave the site at his cost.
- 14.3.7 The contractor shall ensure that no construction leachate (e.g., cement slurry etc.), is allowed to percolate into the ground. Adequate precautions will be taken to safeguard against this including reduction of wasteful curing processes, collection, basic filtering and reuse. The contractor shall follow requisite measures for collecting drainage water run-off from construction areas and material storage sites and diverting water flow away from such polluted areas. Temporary drainage channels, perimeter dike/swale, etc. shall be constructed to carry the pollutant-laden water directly to the treatment device or facility (municipal sewer line).
- 14.3.8 Staging (dividing a construction area into two or more areas to minimize the area of soil that will be exposed at any given time) should be done to separate undisturbed land from land disturbed by construction activity and material storage.
- 14.3.9 The contractor shall comply with the safety procedures, norms and guidelines (as applicable) as outlined in Volume-2, Part 7 Construction Management Practices and Safety, of National Building Code of India, 2016, Bureau of Indian Standards. A copy of all pertinent regulations and notices concerning accidents, injury and first-aid shall be prominently exhibited at the work site. Depending upon the scope & nature of work, a person qualified in first-aid shall be available at work site to render and direct first-aid to casualties. A telephone may be provided to first-aid assistant with telephone numbers of the hospitals displayed. Complete reports of all accidents and action taken thereon shall be forwarded to the competent authorities.
- 14.3.10 The contractor shall ensure the following activities for construction workers safety, among other measures at his cost-

- Guarding all parts of dangerous machinery.
  - Precautionary signs for working on machinery
  - Maintaining hoists and lifts, lifting machines, chains, ropes, and other lifting tackles in good condition.
  - Durable and reusable formwork systems to replace timber formwork and ensure that formwork where used is properly maintained.
  - Ensuring that walking surfaces or boards at height are of sound construction and are provided with safety rails or belts.
  - Provide protective equipment; helmets etc.
  - Provide measures to prevent fires. Fire extinguishers and buckets of sand to be provided in the fire-prone area and elsewhere.
  - Provide sufficient and suitable light for working during night time.
- 14.3.11 The storage of material shall be as per standard good practices as specified in Volume-2, Part 7 Construction Management Practices and Safety of National Building Code of India, 2016, Bureau of Indian Standards and shall be to the satisfaction of the Engineer-in-Charge to ensure minimum wastage and to prevent any misuse, damage, inconvenience or accident. Watch and ward of the Contractor's materials shall be his own responsibility. There should be a proper planning of the layout for stacking and storage of different materials, components and equipments with proper access and proper manoeuvrability of the vehicles carrying the materials. While planning the layout, the requirements of various materials, components and equipments at different stages of construction shall be considered.
- 14.3.12 The contractor shall provide for adequate number of garbage bins around the construction site and the workers facilities and will be responsible for the proper utilization of these bins for any solid waste generated during the construction. The contractor shall ensure that the site and the workers facilities are kept litter free. Separate bins should be provided for plastic, glass, metal, biological and paper waste and labelled in both Hindi and English with suitable symbols.
- 14.3.13 The contractor shall prepare and submit „Spill prevention and control plans“ before the start of construction, clearly stating measures to stop the source of the spill, to contain the spill, to dispose the contaminated material and hazardous wastes, and stating designation of personnel trained to prevent and control spills. Hazardous wastes include pesticides, paints, cleaners, and petroleum products.
- 14.3.13.1 Contractor shall collect & submit the relevant material certificates for materials if directed by the Engineer in charge with high recycled (both post-industrial and post-consumer) content, including materials like RMC mix with fly-ash, glass with recycled content, calcium silicate boards etc.
- 14.3.14 Water use during Construction Contractor should spray curing water on concrete structure and shall not allow free flow of water. Concrete structures should be kept covered with thick cloth / gunny bags and water should be sprayed on them.
- 14.3.15 The Contractor shall remove from site all rubbish and debris generated by the Works and keep Works clean and tidy throughout the Contract Period. All the serviceable and non-serviceable (malba) material shall be segregated and stored separately. The malba obtained during construction shall be collected in well-formed heaps at properly selected places, keeping in a view safe condition for workmen in the area. Materials which are likely to cause dust nuisance or undue environmental pollution in any other way, shall be removed from the site at the earliest and till then they shall be suitably covered. Glass & steel should be dumped or buried separately to prevent

injury. The work of removal of debris should be carried out during day. In case of poor visibility artificial light may be provided.

14.3.16 The contractor shall use treated recycled water of appropriate quality standards for construction, if available.

**15. SITE OFFICE, VEHICLES AND ALLIED FACILITIES:**

- 15.1 The Contractor shall have to provide site office as described in table below, with toilet facility and one attendant.
- 15.2 Four wheeled vehicle (not older than one year, with driver, fuel & lubricants, insurance, road taxes, necessary road permits, fitness certificates etc. complete) as mentioned hereunder and as per satisfaction of the Engineer shall be provided for the use of Engineer-in-charge and other supervisory staff.
- 15.3 In addition the Contractor shall provide Computer and Laser Printer with Operator as described herein.
- 15.4 For these items the contractor shall make sufficient provision in his rates. In case contractor fails to provide any of the above the Engineer-in-charge shall be authorized to make arrangement at the cost of contractor and make deductions in payments due to contractor at market rates but in any case not less than the rates mentioned hereunder.
- 15.5 This/these vehicle(s) subject to the note below shall remain in operation as mentioned in table hereunder. These vehicles and computers shall be returnable to the contractor thereafter.

**Note:-**

In case of delay in completion of project beyond stipulated period not attributable to the Contractor, the requirement of vehicles and computers may be reviewed by the Engineer and at his sole discretion he may reduce their numbers as he deems fit- keeping in view efficiency of supervision.

<b>Contract Value</b>	<b>Site office</b>	<b>Four-wheeled vehicle (Model not later than one year)</b>	<b>Average monthly run on per quarter basis</b>	<b>Monthly Rate of Recovery for each vehicle if not provided (Rs)</b>	<b>Desktop/Laptop Computer with Laser Printer (new) with operator</b>	<b>Monthly Rate of Recovery for each, if not provided (Rs)</b>	<b>Period for which to be provided</b>
Rs. 1.50 Cr to Rs. 5.00 Cr	One (20 sqm)	One TUV 300/Bolero or equivalent)	2000 km.	40000.00	One as per latest specification and to the satisfaction of Engineer-in-charge	50000.00 for each Desktop/ Laptop and Laser Printer & 12000/ month for each operator	Fixed period of 6 months. Any time during the contract period
More than 5.00 Cr to Rs. 10.00 Cr	One (30 sqm)	One (Dzire/TUV 300/Bolero or equivalent)	3000 km	47500.00	One as per latest specification and to the satisfaction of Engineer-in-charge	50000.00 for each Desktop/ Laptop and Laser Printer & 12000/ month for each operator	Initial contract period including trial run period and also including extension of time if any.
More than 10.00 Cr to Rs. 25.00 Cr	One (30 sqm) + One additional (20 sqm)	One (Dzire/TUV 300/Bolero or equivalent)	3000 km	47500.00	One as per latest specification and to the satisfaction of Engineer-in-charge	50000.00 for each Desktop/ Laptop and Laser Printer & 12000/ month for each operator	
More than 25.00 Cr to Rs. 50.00 Cr	One (30 sqm) + One additional (20 sqm) with attendant	Two MPVs as per requirement of Engineer	3000 km	47500.00	Two as per latest specification and to the satisfaction of Engineer-in-charge	50000.00 for each Desktop/ Laptop and Laser Printer & 12000/ month for each operator	
More than 50.00 Cr to Rs. 100.00 Cr	One (30 sqm) + Two additional (20 sqm) with attendant	One SUV (Innova or equivalent) + Two MPVs as per requirement of Engineer	3500 km	65000.00 for SUV and Rs. 50000.00 for other Vehicles,	Three Laptop and Laser Printer as per latest specification and to the satisfaction of Engineer-in-charge	70000.00 for each Laptop and Laser Printer & 12000/ month for each operator	Initial contract period including trial run period and also including extension of time if any.
More than 100.00 Cr to Rs. 150.00 Cr	One (40 sqm) + Three additional (30 sqm)	One SUV (Innova or equivalent) + Three MPVs as per requirement of Engineer	3500 km	65000.00 for SUV and Rs. 50000.00 for other	Three (Two B/W and one laser colour printer) including consumables such	85000/- for each Laptop and allied facilities & 12000/ month	Initial contract period including trial run period and also including extension of time if any.

Contract Value	Site office	Four-wheeled vehicle (Model not later than one year)	Average monthly run on per quarter basis	Monthly Rate of Recovery for each vehicle if not provided (Rs)	Desktop/Laptop Computer with Laser Printer (new) with operator	Monthly Rate of Recovery for each, if not provided (Rs)	Period for which to be provided
	with attendant	Two motorcycle of not less than 150 cc engine capacity with fuel, insurance, taxes etc. complete	2000 km	10000.00	as paper, toners etc. + Three Laptop as per latest specification and to the satisfaction of Engineer-in-charge	for each operator	
More than 150.00 Cr	One (40 sqm) + Three additional (30 sqm) with attendant	One SUV (Innova or equivalent) + Three MPVs as per requirement of Engineer	3500 km	65000.00 for SUV and Rs. 50000.00 for other Vehicles,	Four (Three B/W and one colour laser printer) including consumables such a paper, toners etc. + Three Laptops as per latest specification and to the satisfaction of Engineer-in-charge		Initial contract period including trial run period and also including extension of time if any.
		Three motorcycle of not less than 150 cc engine capacity with fuel, insurance, taxes etc. complete	2000 km	10000.00			

#### 16. Safety Measures to be followed:

- 16.1 Suitable scaffolds should be provided for workmen for all works that cannot safely be done from the ground, or from solid construction except such short period work as can be done safely from ladders. When a ladder is used, an extra mazdoor shall be engaged for holding the ladder and if the ladder is used for carrying materials as well, suitable footholds and hand-hold shall be provided on the ladder and the ladder shall be given an inclination not steeper than 1/4 to 1 (1/4 horizontal and 1 vertical.)
- 16.2 Scaffolding of staging more than 3.6 m (12ft.) above the ground or floor, swung or suspended from an overhead support or erected with stationary support shall have a guard rail properly attached or bolted, braced and otherwise secured at least 90 cm. (3ft.) high above the floor or platform of such scaffolding or staging and extending along the entire length of the outside and ends thereof with only such opening as may be necessary for the delivery of materials. Such scaffolding or staging shall be so fastened as to prevent it from swaying from the building or structure.
- 16.3 Working platforms, gangways and stairways should be so constructed that they should not sag unduly or unequally, and if the height of the platform or the gangway or the stairway is more than 3.6 m (12ft.) above ground level or floor level, they should be closely boarded, should have adequate width and should be suitably fastened.
- 16.4 Every opening in the floor of a building or in a working platform shall be provided with suitable means to prevent the fall of person or materials by providing suitable fencing or railing whose minimum height shall be 90 cm. (3ft.)
- 16.5 Safe means of access shall be provided to all working platforms and other working places. Every ladder shall be securely fixed. No portable single ladder shall be over 9m. (30ft.) in length while the width between side rails in rung ladder shall in no case be less than 29 cm. for ladder up to and including 3 m. (10 ft.) in length. For longer ladders, this width should be increased at least 1/4 for each additional 30 cm. (1 foot) of length. Uniform step spacing of not more than 30 cm shall be kept. Adequate precautions shall

be taken to prevent danger from electrical equipment. No materials on any of the sites or work shall be so stacked or placed as to cause danger or inconvenience to any person or the public. The contractor shall provide all necessary fencing and lights to protect the public from accident and shall be bound to bear the expenses of defense of every suit, action or other proceedings at law that may be brought by any person for injury sustained owing to neglect of the above precautions and to pay any damages and cost which may be awarded in any such suit; action or proceedings to any such person or which may, with the consent of the contractor, be paid to compensate any claim by any such person.

- 16.6 Use of hoisting machines and tackle including their attachments, anchorage and supports shall conform to the following standards or conditions :-
- 16.6.1
- 16.6.1.1 These shall be of good mechanical construction, sound materials and adequate strength and free from patent defects and shall be kept repaired and in good working order.
- 16.6.1.2 Every rope used in hoisting or lowering materials or as a means of suspension shall be of durable quality and adequate strength, and free from patent defects.
- 16.6.1.3 Use of durable and reusable formwork systems to replace timber formwork and ensure that formwork where used is properly maintained.
- 16.6.2 Every crane driver or hoisting appliance operator shall be properly qualified and no person under the age of 21 years should be in charge of any hoisting machine including any scaffolding winch or give signals to operator.
- 16.6.3 In case of every hoisting machine and of every chain ring hook, shackle swivel and pulley block used in hoisting or as means of suspension, the safe working load shall be ascertained by adequate means. Every hoisting machine and all gear referred to above shall be plainly marked with the safe working load. In case of a hoisting machine having a variable safe working load each safe working load and the condition under which it is applicable shall be clearly indicated. No part of any machine or any gear referred to above in this paragraph shall be loaded beyond the safe working load except for the purpose of testing.
- 16.6.4 The contractors shall notify the safe working load of the machine to the Engineer whenever he brings any machinery to site of work and get it verified by Engineer.
- 16.7 Motors, gearing, transmission, electric wiring and other dangerous parts of hoisting appliances should be provided with efficient safeguards. Hoisting appliances should be provided with such means as will reduce to the minimum the risk of accidental descent of the load. Adequate precautions should be taken to reduce to the minimum the risk of any part of a suspended load becoming accidentally displaced. When workers are employed on electrical installations which are already energized, insulating mats, wearing apparel, such as gloves, sleeves and boots as may be necessary should be provided. The worker should not wear any rings, watches and carry keys or other materials which are good conductors of electricity.
- 16.8 These safety provisions should be brought to the notice of all concerned by display on a notice board at a prominent place at work spot. The person responsible for compliance of the safety code shall be named therein by the contractor.
- 16.9 To ensure effective enforcement of the rules and regulations relating to safety precautions the arrangements made by the contractor shall be open to inspection by the Labour Officer or Engineer or their representatives.
- 16.10 Notwithstanding the above clauses as above there is nothing in these to exempt the contractor from the operations of any other Act or Rule in force in the Republic of India.

## 17. FIRST-AID FACILITIES

- 17.1 At every work place, there shall be provided and maintained, so as to be easily accessible during working hours, first-aid boxes at the rate of not less than one box for 150 contract labour or part thereof ordinarily employed.
- 17.2 The first-aid box shall be distinctly marked with a red cross on white back ground and shall contain the following equipment:-
- 17.2.1 For work places in which the number of contract labour employed does not exceed 50-Each first-aid box shall contain the following equipment“s :-
1. 6 small sterilised dressings.
  2. 3 medium size sterilised dressings.
  3. 3 large size sterilised dressings.
  4. 3 large sterilised burn dressings.
  5. 1 (30 ml.) bottle containing a two per cent alcoholic solution of iodine.
  6. 1 (30 ml.) bottle containing salvolatile having the dose and mode of administration indicated on the label.
  7. 1 snakebite lancet.
  8. 1 (30 gms.) bottle of potassium permanganate crystals.
  9. 1 pair scissors.
  10. 1 copy of the first-aid leaflet issued by the Director General, Factory Advice Service and Labour Institutes, U.P. Jal Nigam of India.
  11. 1 bottle containing 100 tablets (each of 5 gms.) of aspirin.
  12. Ointment for burns.
  13. A bottle of suitable surgical antiseptic solution.
- 17.2.2 For work places in which the number of contract labour exceed 50. Each first-aid box shall contain the following equipments.
1. 12 small sterilised dressings.
  2. 6 medium size sterilised dressings.
  3. 6 large size sterilised dressings.
  4. 6 large size sterilised burn dressings.
  5. 6 (15 gms.) packets sterilised cotton wool.
  6. 1 (60 ml.) bottle containing a two per cent alcoholic solution iodine.
  7. 1 (60 ml.) bottle containing salvolatile having the dose and mode of administration indicated on the label.
  8. 1 roll of adhesive plaster.
  9. 1 snake bite lancet.
  10. 1 (30 gms.) bottle of potassium permanganate crystals.
  11. 1 pair scissors.
  12. 1 copy of the first-aid leaflet issued by the Director General Factory Advice Service and Labour Institutes /Department of India.
  13. A bottle containing 100 tablets (each of 5 gms.) of aspirin.
  14. Ointment for burns.
  15. A bottle of suitable surgical antiseptic solution.
- 17.3 Adequate arrangements shall be made for immediate recoupment of the equipment when necessary.
- 17.4 Nothing except the prescribed contents shall be kept in the First-aid box.
- 17.5 The first-aid box shall be kept in charge of a responsible person who shall always be readily available during the working hours of the work place.

- 17.6 A person in charge of the First-aid box shall be a person trained in First-aid treatment in the work places where the number of contract labour employed is 150 or more.
- 17.7 In work places where the number of contract labour employed is 500 or more and hospital facilities are not available within easy distance from the works. First-aid posts shall be established and run by a trained compounder. The compounder shall be on duty and shall be available at all hours when the workers are at work.
- 17.8 Where work places are situated in places which are not towns or cities, a suitable motor transport shall be kept readily available to carry injured person or person suddenly taken ill to the nearest hospital.

**18. Minimum Quality Assurance Plan:**

A Quality Assurance plan will be submitted by the contractor both in respect of incorporating details as given below for the approval of Engineer-in-Charge:

1. Number of required tests and frequency of testing as indicated in the mentioned in clause-11 under schedule 'F' & Provisions of BIS Code and Standard Practices shall be followed as per directions of the Engineer-in- Charge.
2. Machinery and other Tool & Plants required to be deployed at site by the contractor. Time schedule by which each machinery & Tool & Plants is to be brought at site shall be indicated.
3. A field laboratory to be setup by the contractor at site of work as per direction of the Engineer-in-Charge. All the testing equipments required shall be arranged by the contractor and shall be clearly mentioned.

**4. Maintenance of Register of Tests -**

- i. All the registers of tests carried out at Construction Site or in outside laboratories shall be maintained by the contractor in a register of formats suggested by Engineer-in-charge.
  - ii. All Samples of materials including Cement Concrete Cubes shall be taken jointly with Contractor by Junior Engineer. All the necessary assistance shall be provided by the contractor. Cost of sample materials is to be borne by the contractor and he shall be responsible for safe custody of samples to be tested at site.
  - iii. All the test in field lab setup at Construction Site shall be carried out by the Engineering Staff deployed by the contractor which shall be 100% witnessed by Junior Engineer (JE). At least 10% of the tests are to be witnessed by the Assistant Engineer (AE).
  - iv. All the entries in the registers will be made by the designated Engineering Staff of the contractor and same should be regularly reviewed by JE/AE/EE.
  - v. Contractor shall be responsible for safe custody of all the test registers.
5. U.P. Jal Nigam (Urban) may require the Contractor to submit a copy of all test registers and other records along with each alternate Running Account Bill and Final Bill.
  6. Minimum QA plan may vary work to work basis depending upon nature and volume of work.

**SECTION – 5**

**TECHNICAL  
SPECIFICATIONS**

## **SECTION-5**

### **TECHNICAL SPECIFICATIONS**

#### **1.0 SPECIFICATIONS FOR SUPPLY ITEMS**

##### **1.1 General**

This part of the specification sets out the general standards of the material to be supplied by the Contractor. The Engineer shall have power to reject defective materials which do not comply with the specifications. Such materials shall be replaced by the Contractor at his own cost. All materials supplied and works done by the Contractor would conform to the specifications laid down in relevant Bureau of Indian Standard, Codes of Practices or equivalent International Standards subject to approval of the Engineer. Further, the works would be carried out in the spirit of guidelines embodied in the Manual on Water Supply and Treatment published by CPHEEO under the Ministry of Works and Housing, Government of India.

##### **Compliance with Standards**

Whenever reference is made in the contract to specific standards and codes to be met by the goods and materials to be furnished, and work performed or tested, the provisions of the latest current edition or revision of the relevant standards and codes in effect shall apply, unless otherwise expressly stated in the contract. Where such standards and codes are national, or relate to a particular country or region, other authoritative standards which ensure an equal or higher quality than the standards and codes specified will be accepted subject to the Engineer's prior review and written approval. Differences between the standards specified and the proposed alternative standards must be fully described in writing by the Contractor and submitted to the Engineer at least 14 days prior to the date when the Contractor desires the Engineer's approval. In the event the Engineer determines that such proposed deviations do not ensure equal or higher quality, the Contractor shall comply with the standards specified in the documents.

## **Materials General**

All materials incorporated in the works shall be the most suitable for the duty concerned and shall be new and of first class commercial quality, free from imperfection and selected for long life and minimum maintenance.

## **Workmanship General**

Workmanship and general finish shall be of first class quality and in accordance with the best workmanship practice and shall provide what is generally recognized as “water works finish”.

## **Welding**

All welding works shall be done as per standard welding practices, standards laid down by the B.I.S. and as directed by the Engineer. The welding electrodes used would conform to IS : 814 (Part-II) 1974. **Nuts, Bolts, Studs and Washers**

Nuts, bolts, studs and washers used shall conform to the requirements of the appropriate Indian or other approved standards. Nuts and bolts for pressure parts shall be of the best quality bright steel, machined on the shank and under the head, and nuts, bolts shall be of sufficient length so that one tread shall show through the nut when fully tightened conditions. Washers, locking devices shall be provided where necessary and shall be subject to the approval of the Engineer. Where bolts pass through structural members, taper washers shall be fitted wherever necessary, to ensure that no bending stress is caused in the bolt.

## **Protection and Packing for Transportation**

The materials will be required to be packed strictly as per provisions of relevant B.I.S. Codes and in the event of any deviation, the responsibility for damage to the consignment shall rest with the supplier / Contractor.

## **Test Certificate from Manufacturers**

All raw materials as well as finished products shall be procured by the Contractor himself. Necessary test certificates from the manufacturer and / or from the supplier, shall be obtained for all such supplies for particular consignments and submitted to the Engineer or his representative. However, in addition to the above, the Engineer or his representative may instruct the Contractor to further test the sample of materials from any of the consignment (or from each lot) for ascertaining the quality as per specifications at Contractor's cost.

## **Material Testing**

Testing of materials, to be used in the permanent work or ;the quality of finished items, shall generally be done in the laboratory approved by the Engineer or his representative and all testing charges shall be borne by the Contractor, and also the materials for testing shall be provided by the contractor free of cost.

## **List of vendors and Engineer' choice**

For all the items, plants, equipment (civil, mechanical or electrical) which the Contractor does

not manufacture himself and has to procure from other manufacturers/vendors for use, supply or installation under this contract. A list of vendors provided in the bidding documents is to be strictly adhered. For items out-side this list the Contractor would submit a list of vendors from whom such procurements are proposed to be made by him along with complete details of specifications, make, rating capacity etc. for such items, plants and equipment. The final choice of vendor from whom such procurements would ultimately be made by the Contractor, shall rest with the Engineer. Once a vendor has been chosen by the Engineer, no substitution would generally be allowed. The Engineer may, however, permit as a special case, substitution of a vendor if in his opinion an equivalent or better product is offered by the Contractor but Engineer's written prior permission shall have to be obtained for any such substitution.

**Shop Testing of Materials**

All items of work to be used on work as such as shall be liable to inspection and testing before dispatch at the manufacturer's premises or workshop, to see that they conform to the specifications. The relevant test certificates shall accompany the supply. All shop tests would be carried out in presence of the Engineer or his representative.

No materials shall be delivered to the site without inspection having been carried out or waived in writing by the Engineer or his representative. A clear notice of 7 days shall be given to enable the Engineer or his representative to participate in testing.

The manufacturer / contractor shall issue certificate of quality for pipe, sluice, non-return and air valves supplied for the contractor, certifying that the material supplied fully conforms to the provisions of relevant B.I.S. Code of Practice / specifications laid down in the bid documents. Such certificates to accompany every consignment of materials.

**1.2.0 HDPE PIPES**

**1.2.1 Applicable Codes**

The following standards, unless otherwise specified herein, shall be referred. In all cases the latest revision of the Codes shall be referred to. If requirements of this specifications conflict with the requirements of the standards /Codes, this specification shall govern

<b>Code No.</b>	<b>Title/Specification</b>
IS 4984 amendment No.2 1995 or its latest amendments	High Density polyethylene pipes for Water Supply
IS 5382	Rubber sealing rings for gas mains, water mains and sewers.
S 7634-2 (2012):	Laying & jointing of polyethylene (PE) Pipes
IS 2530	Methods of test for polyethylene molding materials and polyethylene Compounds
IS 4905	Methods for random sampling
IS 9845	Method of analysis for the determination of specific and/or

	overall migration of constituents of plastics material and articles intended to come into contact with foodstuffs.
IS 10141	Positive list of constituents of polyethylene in contact with food stuffs, pharmaceuticals and drinking water.

**1.2.2 Specification of Pipes :**

**1.2.2.1-A Colour**

The colour of the pipe shall be black. Each pipe shall contain minimum three equi-spaced longitudinal stripes of width 3 mm (Min) in blue colour. These stripes shall be more than 0.2 mm in depth. The material of the stripes shall be of the same type of resin, as used in the base compound for the pipe.

**1.2.2.1-B Material**

(i) Raw Material

Raw material used to manufacture the HDPE pipes shall be 100% virgin, pre-compounded at manufacturing stage. PE 100 resin or Natural black PE resin conforming to IS: 4984, IS: 7328 and ISO: 4427; for this a certification has to be obtained by the pipe manufacturer from the resin manufacturer as per clause 3.2.3 of IS: 4984. The resin proposed to be used for manufacturing of the pipes should also comply with the following norms as per ISO 9080.

The resin should have been certified by an independent laboratory of international repute for having passed 10,000 hour long term hydrostatic strength (LTHS) test extrapolated to 50 years to show that the resin has a minimum MRS of over 10MPa. Internal certificate of any resin manufacturer will not be acceptable.

Certificate for having passed the full scale rapid crack propagation test as per ISO 13478. High density Polyethylene (HDPE) used for the manufacture of pipes shall conform to designation PEEWA-45-T- 006 of IS 7328. HDPE conforming to designation PEEWA-45- T- 012 of IS 7328 may also be used with the exception that melt flow rate (MFR) shall not exceed 1.10 g/10 min. In addition, the material shall also conform to clause 5.6.2 of IS 7328.

The specified base density shall be between 941.0kg/ m<sup>3</sup> and 946.0kg/ m<sup>3</sup> (both inclusive) when determined at 27°C according to procedure prescribed in IS:7328 .The value of the density shall also not differ from the nominal value by more than 3 kg/ m<sup>3</sup> as per 5.2.1.1 of IS: 7328. The MFR of the material shall be between 0.41 and 1.10 (both inclusive) when tested at 190°C with nominal load of 5 kgf as determined by method prescribed in IS 2530. The MFR of the material shall also be within ± 20 percent of the value declared by the manufacturer. The resin shall be compounded with carbon black. The carbon black content in the material shall be within 2.5 ±0.5% and the dispersion of carbon black shall be satisfactory when tested as per IS 2530.

(ii) Anti-oxidant

The percentage of anti-oxidant used shall not be more than 0.3 percent by mass of finished

resin. The anti-oxidant used shall be physiologically harm less and shall be selected from the list given in IS: 10141.

(iii) Reworked Material

No addition of Reworked/ Recycled Material from the manufacturer,,s own rework material resulting from the manufacture of pipes is permissible and the vendor is required to use only 100% virgin resin compound.

**1.2.2.2 Dimensions of pipes and Ovality of pipe**

Ovality shall be measured at the maximum outside diameter and minimum out-side diameter measured at the same cross section of the pipe, at 300 mm away from the cut end. For pipes to be coiled, the ovality shall be measured prior to coiling for coiled pipes, however, re-rounding of pipe shall be carried out prior to the measurement of ovality. Outside diameter, tolerance and ovality of pipes shall be as per table below:

<b>(Refer Table No. 2 IS 4984-1995)</b>			
<b>S. No</b>	<b>Outside Diameter (mm)</b>	<b>Tolerance (only positive tolerances) (mm)</b>	<b>Ovality (mm)</b>
1	20.0	0.3	1.2
2	25.0	0.3	1.2
3	32.0	0.3	1.3
4	40.0	0.4	1.4
5	50.0	0.5	1.4
6	63	0.6	1.5
7	75.0	0.7	1.6
8	90.0	0.9	1.8
9	110. 0	1.0	2.2
10	125. 0	1.2	2.5
11	140. 0	1.3	2.8
12	160. 0	1.5	3.2
13	180. 0	1.7	3.6
14	200. 0	1.8	4.0

**1.2.2.3 Wall thickness as per allowable hydrostatic designstress-**

The minimum & maximum wall thickness of pipe for the PE100 grade of pipe as per IS :

4984 for PN6, PN8 & PN10 shall be as per table

**(Refer Table No. 5 (Amendment No.2) IS 4984-1995)**

Nominal Dia	Wall Thickness of pipes					
	PN 6		PN 8		PN 10	
DN	Min	Max	Min	Max	Min	Max
1	2	3	4	5	6	7
20	-	-	-	-	-	-
25	-	-	-	-	-	-
32	-	-	-	-	2.4	2.9
40	-	-	2.4	2.9	3.0	3.5
50	2.3	2.8	3.0	3.5	3.7	4.3
63	2.9	3.4	3.8	4.4	4.7	5.4
75	3.5	4.1	4.5	5.2	5.6	6.4
90	4.1	4.8	5.4	6.2	6.7	7.6
110	5.0	5.7	6.6	7.5	8.1	9.2
125	5.7	6.5	7.5	8.5	9.2	10.4
140	6.4	7.3	8.4	9.5	10.3	11.6
160	7.3	8.3	9.6	10.8	11.8	13.2
180	8.2	9.3	10.8	12.1	13.3	14.9
200	9.1	10.3	12.0	13.4	14.8	16.5

#### 1.2.2.4 Length of straight Pipe & Marking on pipe

The length of straight pipe used shall be more than 6 m (excluding 110 mm dia.), or as agreed by Engineer in charge. Short lengths of 3 meter (minimum) up to a Maximum of 10 % of the total supply may be permitted. Each straight length of pipe shall be clearly marked in indelible ink/paint on either end and for coil at both ends or hot embossed on white base every meter throughout the length of pipe/coil with the following information:

- (a) Manufacturer's name and/ or trade mark.
- (b) Designation of pipe(class, nominal dia.)
- (c) Lot No./Batch No.
- (d) BIS certification marking on each pipe.

#### 1.2.2.5 Coiling

The HDPE pipe of 110 mm dia. supplied shall be coiled on drums of minimum diameter of 25 times the nominal diameter of the pipe ensuring that kinking of pipe is prevented. Pipe beyond 110 mm dia shall be supplied in straight length not less than 6m.

#### 1.2.2.6 Appearance

Pipe shall be free from all defect including indentation, delaminating, bubbles, pinholes, cracks, pits, blisters, foreign inclusion that due to Their nature degree or extent detrimentally

affect the strength and Serviceability of the pipe. The pipe shall be as uniform as commercially practicable in colour opacity, density and other physical properties as per relevant IS code or equivalent International Code. The inside surface of each pipe shall be free of scouring, cavities, bulges, dents, ridges and other defects that result in a variation of inside diameter from that obtained on adjacent unaffected portions of the surface. The pipe ends shall be cut clearly and perpendicular to the axis of the pipe.

#### **1.2.2.7 Testing of Pipe**

HDPE pipes shall be subjected to Internal pressure creep rupture test, Longitudinal Revision Test, Overall Migration Test, Density, Melt Flow Rate (MFR), Carbon Black Content and Dispersion Tests.

#### **1.2.3.1 Handling, Transportation storage and Loading & unloading of pipes**

If transportation of HDPE pipes from a distance greater than 300 km than pipes shall be received only when bare coils of pipe have been wrapped with hessian cloth. The truck used for transportation of the PE pipes shall be exclusively used of PE pipes only with no other material loaded-especially no metallic, glass and wooden items. The truck shall not have sharp edges that can damage the pipe. At the time of opening coils it must be remembered that the coiled under tension and must be open in control manner. Straight length should be stored on horizontal racks giving continuous support. Loss/damages during transit, During handling, transportation, storage and lowering, all sections shall be handled by such means and in such a manner that no distortion or damage is done to the section or to the pipes as a whole. Pipe must not be stored or transported where they are exposed to heat sources likely to exceed 60°C. Pipes shall be stored such that they are not in contact with direct sunlight, lubricating or hydraulic oils, petrol, solvents and other aggressive materials. Scores or scratches to a depth of greater than 10 % or more of wall thickness are not permissible; any pipes having such defects should be strictly rejected. PE pipes should not be subjected to rough handling during loading and unloading operations. Rollers shall be used to move, drag the pipes across any surface. Only polyester webbing slings should be used to lift heavy PE (>315mm) pipes by crane. Under no circumstances, chains, wire ropes and hooks be used on PE surface. Pipes shall not be dropped to avoid impact or bump. If any time during handling or during installation, any damage, such as gouge, crack or fracture occurs, the pipe shall be repaired if so permitted by the competent authority before installation.

#### **1.2.3.2 Lowering, Laying of pipes**

IS: 7634 shall be applicable. Before using the pipe following precautions/check shall be taken. Each pipe shall be thoroughly checked for any damages before laying and only the pipes which are approved by the Engineer shall be laid. While installing the pipes in trenches, the bed of the trench should be level and free from sharp edged stones. In most cases, the bedding is not required, as long as the sharp and protruding stones are removed, by sieving the dug earth, before using the same as a backfill material. While laying in rocky areas suitable bed of sand or gravel should be provided. The fill to about 10 to 15 cm above the pipe should be fine sand or screened excavated material. Where hard rock is met with, bed concrete 15 cm

thick of grade M-15 or 20 cm thick sand bed as approved by the engineer may be provided. As PE pipes are flexible, long lengths of fusion-jointed pipes having joints made above ground can be rolled or snaked into narrow trenches. Such trenches can be excavated by narrow buckets. During the pipe laying of continuous fusion jointed systems, due care and allowance should be made for the movements likely to occur due to the thermal expansion/contraction of the material. This effect is most pronounced at end connections to fixed positions (such as valves etc.) and the branch connections. Care should be taken in fixing by finishing the connections at a time the length of the pipe is minimal (lower temperature times of the day). For summer time installations with two fixed connection points, a slightly longer length of PE pipe may be required to compensate for contraction of the pipe in the cooler trench bottom. The final tie-in connections should be deferred until the thermal stability of the pipeline is achieved. The flexibility of polyethylene pipes allows the pipe to be cold bend. The fusion jointed PE pipe is also flexible as the plain pipe. Thus the total system enables directional changes within the trench without recourse to the provision of special bends or anchor blocks. However, the pipe should not be cold bend to a radius less than 20 times the OD of the pipe. The installation of flanged fittings such as connections to sluice/air/gate valves and hydrant tees etc., requires the use of stub ends (collars/flange adaptor complete with backing rings and gasket. Care should be taken when tightening these flanges to provide even and balance torque. Provision should be made at all heavy fittings installation points for supports (such as anchoring of the flange in the soil) for the flange joint to avoid the transfer of valve wheel turning torque on to the PE flange joint. PE pipe is lighter than water. Hence care should be taken for normal installations where there could be a possibility of flooding of the trench thus the trench shall be kept free of water till the jointing has been properly done. However, weights by way of concrete blocks (anchors) are to be provided so that the PE pipe does not float when suddenly the trench is flooded and the soil surrounding the pipe is washed away. Thus site conditions study is necessary to ensure the avoidance of flotation. Pipe embedment backfill shall be stone-free excavated material placed and compacted to the 95 % maximum dry density.

#### 1.2.3.3 Jointing of HDPE pipes

The pipe shall have a jointing system that shall provide for fluid tightness for the intended service conditions. Jointing between HDPE pipes and specials shall be done as per the latest IS: 7634 part II. **Only Bar coded electro-fusion machine (Automatically Readable) that can read the bar code of the fittings automatically shall be used for jointing of HDPE pipe/fittings. Manual feeding electro-fusion machines are not acceptable for jointing purpose.** An external memory bank must be able to record at least 350 fusion records and be easily accessible and exchangeable. The supplier must be able to provide a full range of system software and data transmission accessories as applicable for data processing. The ability to download fusion records from all memory systems via an RS 232 interface is to be provided. A back-up internal reserve memory with override must to be provided.

The contractor shall ensure that the Pipeline is free from foreign material before fusing the joints. Before joining, the Contractor shall place packing sand under the pipes on both sides of the joint to keep the pipes in line and at the correct alignment during the jointing

process. Alignment clamps with the correct size shells should be used to align the pipe during the electro-fusion cycle.

The Contractor shall ensure that polyethylene pipe is only cut with an approved plastic pipe cutting tool. Before fusion is attempted, he shall remove the oxidized surface of the pipe to be inserted into the electro-fusion coupling. The tool must remove a layer of 0.1 mm to 0.4 mm from the outer surface of the polyethylene pipe. It may also be **noted that no fusion will be allowed without clamping device and only the approved cutting tools** (Hack Saw shall not be allowed for cutting the Pipe) shall be used.

The contractor has to supply all the consumables required for carrying fusion of the joints (like cloth/ paper napkin, acetone etc.).

If, upon inspection, the Engineer-in-charge determines a joint is defective, Contractor shall remove the joint by an approved method. The cost of this work shall be borne by the Contractor.

Contractor shall arrange generator for power supply for fusion machine. Taking power connection from electric poles, connections without written permission from concerned authorities or residential premises is strictly not permitted.

#### **1.2.3.4 Bedding**

In case of sandy strata no separate bedding is required. However the bottom face/trench bed where pipe shall be placed shall be compacted to provide a minimum compaction corresponding to 95 % of maximum dry density. The pipe bedding should be placed so as to give complete contact between the bottom of the trench and the pipe.

#### **1.2.3.5 Back Filling**

Backfilling should be placed in layers not exceeding 15 cm thickness per layer, and should be compacted to a minimum of 95% maximum dry density. The refilling should be done on both sides of pipe together & height difference in earth fill on each side should not be more to cause lateral movement of pipe.

Filling in trenches shall be commenced soon after the joints of pipes have been tested and passed/ ensured for no leakage. The space around the pipes shall be cleared of all debris, brick bats etc. Where the trenches are excavated in hard/soft soil, the filling shall be done with selected earth free from stones, boulders, and debris and sharp edge hard materials on the sides and top of pipes in layers not exceeding 20 cm in depth. Each layer shall be watered, rammed and consolidated. All clods and lumps of earth exceeding 8 cm in any direction shall be broken or removed before the excavated earth is used for refilling.

#### **1.2.3.6 Compaction**

Compaction within distances of 15 cm to 145 cm from the pipe should be usually done with hand tampers. The backfill material should be compacted not less than 95 % of maximum dry density. Backfill material placed within 0.5 m of sub grade shall be compacted to a density of

not less than 95 percent of maximum density and the relative moisture content shall be not more than 102 percent of optimum moisture content. Sub grade shall be defined for this section as the elevation of the bottom of any aggregate material placed for pavement or sidewalk or the bottom of the topsoil for turf establishment.

The backfill material shall be placed in layers of 150 mm thick and well compacted. During the compaction the backfill shall have a uniform moisture content equal to or a little above the optimum moisture content recorded in the compaction test. Backfill shall be compacted to a dry density of not less than 95% of the maximum dry density. The suitable mechanical rammers may be used for the compaction.

The Contractor shall assume responsibility to correct settlement of trenches for a period of one year from the date of Substantial Performance or as otherwise directed by the Engineer.

#### **1.2.3.7 Disposal of Excess Earth**

The responsibility of making all the arrangements for the disposal of all surplus material from any excavation, which is material extra over the selected excavated material needed for use in the backfilling, grading or other purpose and for handling of this surplus material over the whole distance from the point of excavation to the point of legal disposal sites approved by Engineer-in-charge.

The disposal of the said material in unauthorized places is strictly prohibited and the contractor will be held responsible for such acts. The cost incurred in such unauthorized dumping will be borne by the contractor.

During working in the narrow streets or any other type of streets where the excavated material cause inconvenience / objection , it should be removed immediately to nearby temporary storage area and after completion the same excavated earth should be taken back and use as a filling material. The excess earth at the temporary storage area should be disposed in the legal disposal site. The contractor is not entitled to claim on disposal of excess earth and temporary storage of excavated earth and claims shall not be entertained by the employer. The cost occurred shall be totally born by the Contractor.

#### **1.3.0 HDPE FITTINGS AND SPECIALS**

All the electro fusion fittings included in this document should be designed for use in water distribution systems and be manufactured/supplied by manufacturers having ISO 9001: 2000 certification for their quality systems. The products should comply with the following specific requirements.

1. The products shall comply with the requirements of BS EN 12201-3: 2003, BS EN 1555-3 or ISO 8085-3.
2. All the fittings shall be of SDR 11 rating. The product group used for drinking water applications should have undergone type test by WRC-NSF, U.K according to BS 6920 in any of their Certified Laboratories like WRC-NSF/DVGW/KIWA/SPGN and certificate of Compliance to be produced for the following parameters:

- a. Odour & Flavour of Water
  - b. Appearance of Water
  - c. Growth of Micro Organism
  - d. Extraction of substances that may be of concern to Public Health (CytoToxicity)
  - e. Extraction of Metals
3. All the products shall be manufactured by injection moulding using virgin compounded PE 100 polymer having a melt flow rate between 0.5 – 1.1 grams/10 minutes and shall be compatible for fusing on either PE 80 or PE 100 distribution mains manufactured according to the relevant national or international standards. The polymer used should comply with the requirements of BS 3412 and/or BS EN12201-1.
  4. The fittings intended for water distribution applications shall be coloured blue for the clear identification of the services.
  5. All the electro-fusion products should be individually packed so that they can be used instantaneously at site without additional cleaning process. The protective packing should be transparent to allow easy identification of the fittings without opening the bags.
  6. The electro fusion products should be with only a single heating coil to fully electrofuse the fitting to the adjoining pipe or pipe component as applicable. The heating coils shall be terminated at terminal pins of 4.0 or 4.7 millimeter diameter, protected with terminal shrouds. Each terminal shroud should be additionally protected with polyethylene shroud caps.
  7. No heating element shall be exposed and all coils are to be integral part of the body of the fitting. The insertion of the heating element in the fitting should be part of the injection moulding process and coils inserted after the injection moulding process or attached to the body of the fitting as a separate embedded pad etc. are strictly not acceptable.
  8. The pipe fixation shall be achieved by external clamping devices only and integral fixation devices are not acceptable.
  9. The brand name, size, raw material grade, SDR rating and batch identification are to be embedded as part of the injection moulding process. Each fitting should also be supplied with a barcode sticker for fusion parameters attached to the body for setting the fusion parameters on an automatic fusion control box. The barcode sticker should also include the fusion and cooling time applicable for the fitting for the manual setting of a manual fusion control box.
  10. The fittings should be V-regulated type designed to fuse at a fusion voltage of 40 volts AC.
  11. The heating elements should be designed for fusion at any ambient temperatures between -5 to +40 degree centigrade at a constant fusion time i.e. without any compensation of fusion time for different ambient temperatures.
  12. A limited path style fusion indicator acting for each fusion zone as visual recognition of completed fusion cycle should be incorporated into the body of each fitting near the terminals. The fusion indicators should not allow the escape of the molten polymer through them during or after the fusion process.

13. All the sockets in the electrofusion fittings should include a method of tapping controlling the pipe penetration (pipe positioner/stopper).

#### **1.3.1 Flanged Joints**

These are used for jointing HDPE pipes particularly of larger size to valves and vessels and large size metal pipes where strength in tension is required. It consists of flanges either loose or welded to the pipe ends. It is recommended that suitable metallic backing plates be used to support the polyethylene flanges to enable them to be bolted together. Injection moulded polyethylene flanges with metal inserts of 6 to 9 mm thickness may also be used. In most cases, sealing is improved by incorporating a natural or synthetic rubber gasket between polyethylene flanges.

#### **1.3.2 Test to Establish Perfectibility/portability of work**

Specimen of pipe shall be tested to establish the suitability for use in carrying portable water

- (i) Smell of the extract
- (ii) Clarity of the colour of the extract
- (iii) Acidity and Alkalinity
- (iv) Global migration UV absorbing material Heavy metals
- (v) Unreacted monomers (styrenes) and biological tests

#### **1.3.3 Hydraulic Test**

##### **1.3.6.1 Factory Hydraulic Test**

Factory tests of the pipes shall be carried out as per the test pressure of the selected pipes.

#### **1.3.4 Field Hydraulic Test for HDPE Pipes**

After laying the pipe hydraulic test shall be done to conform the quality of work and material. There shall not be any signs of localized swelling, leakage or weeping. It should conform to IS : 4984 & IS 7634.

- i. The Sectional Hydraulic Test shall be carried out after the pipeline section to be tested has been laid jointed and backfilled to a depth sufficient to prevent floatation, but leaving the joints exposed which are to be tested. The sections to be tested shall be to the approval of the Engineer and shall not be longer than 2000 m or 500 m when either the pipeline is laid adjacent to or underneath the carriageway or when section includes an air valve chamber. The joints between each tested section shall be left exposed until the pipeline has passed the test on completion.
- ii. Each length of the pipeline to be tested shall be capped or blanked off at each end and securely strutted or restrained to withstand the forces which will be exerted when the test pressure is applied. Air valves already fitted shall be permitted to function during the test
- iii. Proposals for testing where thrusts on structures are involved, even where thrust flanges on

the piping are installed, shall be with the prior approval of the Engineer.

- iv. The length under test shall be filled making certain that all air is displaced through an airvalve or any other appropriate mechanism. The test length shall then remain under constant moderate pressure, 10 to 20m head of water, for a period of several hours until the pressure can be maintained without additional pumping.
- v. The pressure shall then be slowly increased at a maximum rate of 1 bar per minute to the full test pressure and pumping discontinued for 3 hours or until the pressure has dropped by 10m, whichever occurs earlier. Thereafter pumping shall be resumed and continued until the test pressure has been restored. The quantity of water pumped to restore the pressure, which is called make up water, shall be the measure of thermal expansion or leakage from discontinuation of pumping until its resumption. The maximum makeup water shall be as below:

OD of the Pipeline In mm	Litres per 1000m of Pipe length Tested		
	One Hour Test	Two Hour Test	Three Hour Test
63	9	14	24
110	16	31	50
160	37	74	112
200	50	87	124
315	136	285	422
400	174	347	521

- The maximum allowable test pressure shall be 1.5 times the system design pressure or pipe rating whichever is higher
- Notwithstanding the satisfactory completion of the hydraulic test, if there is any discernible leakage of water from any pipe or joint, the Contractor shall, at his own cost, replace the pipe, repair the pipe or re-make the joint and repeat the hydraulic test with cost including the cost of water. Water used for hydrostatic test shall be clean and potable.
- Pipelines shall be tested as above except where the Engineer issues such instructions as are necessary for testing parts of the Works that have been designed for stresses limited by considerations other than those applying to the pipeline systems.
- Test pressures are to be measured in kg/cm<sup>2</sup> at the centre of the blank flange situated at the lowest end of the pipeline under test. Unless otherwise specified the test pressure shall be as stated below.

### 1.3.5 Measurement

The net length of fixed pipe including specials shall be measured in running meters correct to a cm. Excavation, refilling, masonry and concrete work wherever required shall be measured and paid for separately under relevant items of work. Payment shall be made as per relevant items in BOQ.

## 1.4.0 DUCTILE IRON PRESSURE PIPES AND SPECIAL WITH TYTON JOINTS

### 1.4.1 Scope

This specification covers the requirements for manufacturing, testing, supplying, jointing and testing at worksite Ductile iron pipes and fittings used for water conveyance.

### 1.4.2 Applicable Codes

The manufacturing testing, supplying, jointing and testing at work sites of Ductile Iron pipes and fittings shall comply with all currently applicable statutes, regulations, standards and codes. In particular, the following standards, unless specified herein shall be referred. In all cases, the latest revision of the codes shall be referred to. If requirements of specifications conflict with the requirements of the codes and standards, this specification shall govern.

### 1.4.3 Materials

IS: 8329(including latest amendments) Specification for Centrifugally Cast (spun) Ductile Iron pressure pipes for water, gas and sewage. In particular the following standards, unless otherwise specified herein, shall be referred. In all cases, the latest revision of the standards/codes shall be referred to. Other IS: Codes not specifically mentioned here but pertaining to the use of DI pipes shall be part of this Specification.

### 1.4.4 I.S. Number Title

IS: 8329: 2000 Amend No.-1- 2000 or its latest amendments	Centrifugally cost (spun) ductile iron Pressure pipes for water, gas and sewage (third revision)
IS: 1500	Methods for Brinell hardness test for metallic materials
IS: 1387	General requirements for supply of metallurgical materials
IS: 9523: 2000 or its latest amendments	Ductile iron fittings for pressure pipes for water, gas and sewage.
IS: 12288: 1987 or its latest amendments	Code of practice for use and laying of ductile iron pipes.
IS: 5382: 1985 or its latest amendments	Rubber sealing rings for gas mains, water mains and sewer (first Revision)
IS: 12820	Dimensional requirement., of rubber gaskets for mechanical Joints and push on joints for use with cast Iron pipes and fitting s for carrying water, gas and sewage.
ISO: 4179	Ductile iron pipes for pressure and non-pressure-Centrifugal cement mortar lining - General requirements.
ISO: 2531	Ductile iron pipes, fitting and accessories for pressure pipe lines.

### 1.4.5 Manufacturing

#### 1.4.5.1 General

DI pipes and DI fittings shall be systematically checked for any manufacturing defects by experienced supervisors and a very high standard quality shall be maintained. Engineer shall at all reasonable times have free access to the place where the pipes and fittings are manufactured for the purpose of examining and testing the pipes and fittings and for witnessing the test and manufacturing. All tests specified either in this specification or in the relevant Indian Standards shall be performed by the supplier/contractor at his own cost and in presence of Engineer if desired. For this, sufficient notice before, testing of the pipes and fittings shall be given to Engineer. If the test is found unsatisfactory, Engineer may reject any or all pipes and fittings of that lot. The decision of Engineer in this matter shall be final and binding of the contractor and not subject to any arbitration or appeal.

#### **1.4.5.2 Materials**

The general requirements relating to the supply of material shall be as per IS:1387. The material for DI fittings shall conform to IS:9523.

#### **1.4.5.3 Dimensions and Tolerance**

The internal diameter, thickness and length of barrel, dimensions of pipes and fittings shall be as per the relevant tables of IS.8329/IS:9523 for different class of pipes and fittings.

The tolerances for pipes and fittings regarding dimensions and deviations from straight line in case of pipes shall be as per relevant IS codes.

The standard weight of uncoated pipes and fittings and the permissible tolerances shall be per relevant IS codes.

#### **1.4.5.4 Workmanship and Finish**

The pipes and fittings shall be stripped, with all precautions necessary to avoid warping or shrinking defects. The pipes and fittings shall be free from defects, other than any unavoidable surface imperfections which result from the method of manufacture and which do not affect the use of the pipes in the opinion of Engineer. The pipes and fittings shall be such that they could be cut, drilled or machined. The hardness of the external unmachined surface shall not exceed 230 HBS. The pipes shall be centrifugally cast (spun) Ductile iron pipes for water and sewage conforming to the IS 8329: 2000. The pipes used shall be either with push on joints (Rubber Gasket Joints) or Flanged joints. The class of pipe to be used shall be of the class K-7 & K-9. The pipes shall be coated with bitumen and have factory provided cement mortar lining in the inside as per the provisions of the IS 8329:2000. The pipes are supplied in standard length of 4.00, 5.00, 5.50 and 6.00 meters length with suitably rounded or chamfered ends. Each pipe of the push on joint variety shall also be supplied with a rubber EPDM/(SBR) gasket. The flanged joints shall conform to the Clause 6.2 of IS: 8329. The pipe supply shall include one rubber gaskets for each flange.

In the case of flanged pipes the flanges shall be at the right angles to the axis of the pipe and machined on face. The bolt holes shall be drilled and located symmetrically off the center line. The bolt hole circle shall be eccentric with the bore and bolt holes equally spaced. The

flanges shall be integrally cast with the pipes and fittings and the two flanges of the pipes shall be correctly aligned. Specifications of sockets and spigot pipes, classes K7 and K9 are mentioned below.

(Refer Table 2 IS 8329-2000 or its latest amendments)(in mm)

Nominal Diameter	External Diameter	Barrel wall thickness	
		K7	K9
DN	DE		
80	98	5	6.0
100	118	5	6.0
125	144	5	6.0
150	170	5	6.0
200	222	5	6.3
250	274	5.3	6.8
300	326	5.6	7.2
350	378	6.0	7.7
400	429	6.3	8.1
450	480	6.6	8.6

Specification of (PN 10) Standard flange Drilling for screwed Flanges and Welded Flange are mentioned below:

(Refer Table 3 IS 8329-2000)(in mm)

Nominal Diameter	Outer Diameter of flange	Holes		Bolt size
		Number	Dia(d)	
DN	D			Metric
80	200	8	19	M16
100	220	8	19	M16
125	250	8	19	M16
150	285	8	23	M20
200	340	12	23	M20
250	400	12	28	M24
300	455	12	28	M24
350	520	16	28	M24
400	580	16	31	M27
450	640	20	31	M27

500	715	20	34	M30
600	840	20	37	M33
700	910	24	37	M33
750	970	24	37	M33
800	102	24	40	M36
900	112	28	40	M36
1000	125	28	43	M39

Specifications of (PN 16) standard Flange Drilling for screwed Flanges and Welded flange are mentioned below:

(Refer Table 4 IS 8329-2000) (in mm)

Nominal Diameter	Outer diameter of flange	Holes		Bolt size
		Number	Dia(d)	
DN	D			Metric
80	200	8	19	M16
100	220	8	19	M16
125	250	8	19	M16
150	285	8	23	M20
200	340	12	23	M20
250	400	12	28	M24
300	455	12	28	M24
350	520	16	28	M24
400	580	16	31	M27
450	640	20	31	M27
500	715	20	34	M30
600	840	20	37	M33
700	910	24	37	M33
750	970	24	37	M33
800	102	24	40	M36
900	112	28	40	M36
1000	125	28	43	M39

#### 1.4.6 Testing

##### 1.4.6.1 Mechanical Tests

Mechanical tests shall be carried out during manufacture of pipes and fittings as specified in relevant IS codes. Mechanical test are carried out during the manufacture. One test shall be conducted for every batch of production. The results so obtained shall be considered to

represent all the pipes and fittings of different sizes manufactured during that period and the same shall be submitted to Owner/Engineer. The method for tensile tests and the minimum tensile strength requirement for pipes and fittings shall be as per relevant IS codes. Tensile Test shall be conducted by cutting a sample from the spigot end of the pipe. This sample may be cut perpendicular to or parallel with the pipes axis, but in case of dispute the parallel to axis sample shall be used. Two methods of measuring the tensile strength may be used at the manufacturer's option.

Method 1 - Machine the test bar to its nominal diameter + 10 percent, measure the actual diameter before the test with an accuracy of 0.01 mm and use this measured diameter to calculate the cross-sectional area and the tensile strength; or:

Method 2 - Machine the test bar to its nominal area S0 within a specified tolerance on diameter and use the nominal area to calculate the tensile strength..

#### **1.4.6.2 Brinell Hardness Test**

For checking the Brinell hardness, the test shall be carried out on the test ring or bars cut from the pipes used for the ring test and tensile test in accordance with IS 1500. When tested in accordance with IS 1500, the Brinell hardness shall not exceed 230 HB on the external unmachined surface.

#### **1.4.6.3 Retests**

If any test piece representing a lot fails in the first instance, two additional tests shall be made on test pieces selected from two other pipes from the same lot. If both the test results satisfy the specified requirements, the lot shall be accepted. Should either of these additional test pieces fail to pass the test, the lot shall be liable for rejection.

#### **1.4.6.4 Marking**

Each pipe and fitting shall have cast stamped or indelibly painted on it with the following appropriate marks:

- a) The nominal diameter.
- b) Class reference.
- c) Mass of pipe.
- d) Date of manufacture and
- e) Manufacturer's name, initials or identification mark. Marking shall be done as per relevant IS Code.

#### **1.4.7 Jointing**

##### **1.4.7.1 General**

Jointing of DI pipes and fittings shall be done as per the requirements of specifications and as per the relevant IS code. After jointing, extraneous material, if any, shall be removed from the inside of the pipe. In case, rubber sealing rings/gaskets are used for jointing these shall conform relevant IS codes.

#### 1.4.7.2 Spigot And Socket Pipes

The Spigot and socket pipes and DI fittings shall have push on joints as specified in IS code/ as recommended by manufacturer. The gaskets/sealant used for push on joints/flanged joints shall be suitable for water conveyance. In jointing ductile iron spigot and socket pipes and fittings with tyton flexible joints the contractor shall take into account the manufacturer's recommendations as to the methods and equipment to be used in assembling the joints. In particular the Contractor shall ensure that the spigot end of the pipe to be jointed is smooth and has been properly chamfered, that the rubber ring as per relevant IS code is correctly positioned in line, before the joint is made. The rubber rings and any recommended lubricant shall be obtained only through the pipe supplier or as otherwise directed by engineer.

#### 1.4.7.3 Flanged Pipes

The gaskets used between flanges of pipes shall be compressed fiber board or natural/synthetic rubber conforming to IS:638 of thickness between 1.5 to 3 mm suitable for water conveyance and as specified by manufacturer. The fiber board shall be impregnated with chemically neutral mineral oil and shall have a smooth and hard surface. Its weight per square meter shall be not less than 112 g/mm thickness. Each bolt should be tightened a little at a time taking care to tighten diametrically opposite bolts alternatively. The practice of fully tightening the bolts one after another is highly undesirable. The bolts shall be of mild steel unless otherwise specified. They shall be coated with coal tar epoxy coating after tightening.

##### 1.4.7.3.1 Restrained Joint Specification for Ductile Iron Pipes

Restrained joint DI pipes and fittings shall be used at bends, Tees, reducers etc or with restricted accessibility or in case of heavy thrust forces or as directed by Engineer-in-Charge. The use of concrete anchor/thrust blocks shall be reduced. The Contractor shall submit with his bid the full details of the type of restrained joint proposed to use.

The manufacturer will have to demonstrate the allowable operating pressure of the proposed restrained joint by type test duly approved by third party inspection agency. The allowable operating pressure & permissible angular deflection for various size range shall be as mentioned given below:

DN	DE, mm	Allowable operating Pressure* (PFA), bar	Allowable Angular Deflection, (Degree)
100	118	40	5
150	170	40	5
200	222	40	4
250	274	38	4
300	326	35	4
350	378	28	3
400	429	25	3

500	532	25	3
600	635	24	2
700	738	22	1.5
800	842	20	1.5
900	945	20	1.5
1000	1048	20	1.5
1100	1152	20	1
1200	1255	20	1

Double Chamber restrained DI Pipes and Fittings shall be supplied with internal OPC lining and external zinc coating with finish layer of Blue Epoxy conforming to IS 8329:2000/IS 9523:2000 with latest amendment.

#### **1.4.7.4 Coating**

Coating shall not be applied to any pipe and fitting unless its surface is clean dry and free from rust. All DI pipes and DI fittings shall be supplied internally (cement mortar lining) and externally (bituminous coating) coated as under.

##### **1.4.7.4.1 Cement Mortar Lining**

###### **Cement**

The cement used for the lining shall conform to the existing standards on cement, The type of cement to be used is to be mutually decided between the purchaser and manufacturer. Normal recommendations are:

Portland cement (as per IS 8112 or IS 455) mortar lining perform rather well and have an expected life of approximately 50 years in soft water with moderate amount of aggressive Co<sub>2</sub> and when Ph is within 6 to 9. Longer service life can be obtained by increasing the mortar lining thickness.

Where cement mortar lining may be exposed to sulphate attack, ordinary Portland cement should be replaced by sulphate resisting Portland cement (as per IS 12330 or IS 6909).

The sulphate concentration limit for sulphate resisting Portland in approximately 3000 mg/liter, the same as blast furnace slag cement which naturally possess a good resistant to sulphate attack.

High alumina cement (as per IS 6452) mortar lining is suitable for continuous use of pH between 4 and 12 and no sever damage occur after occasional exposure to pH 3 to 4 and 12 to 13.

The recommended type of cement used for lining are as given in table .

**(Refer Table 14 IS 8329-2000)**

	<b>Water Characteristics</b>	<b>Portland</b>	<b>Sulphate Resisting Cements (including Blast-Furnace Slag cement)</b>	<b>High alumina Cement</b>
1.	Minimum value of pH	6	5.5	4
2.	Maximum Content (mg/l) of:-			
3.	Aggressive CO <sub>2</sub>	7	15	No limit
4.	Sulphates (SO <sub>4</sub> )	400	3000	No limit
5.	Magnesium (Mg <sup>++</sup> )	100	500	No limit
6.	Ammonium (NH <sub>4</sub> )	30	30	No limit

#### **Sand**

The sand use shall have a controlled granulometric distribution from fine to coarser elements; it shall be clean and shall be composed of inert, hard, strong and stable granular particles. The fine fraction comprising particles passing through a sieve of aperture size 0, 125 mm shall not be more than 10 percent by mass. The coarsest fraction (comprising particles which do not pass through a sieve of the aperture size closest to half the normal thickness of the mortar lining) shall not exceed 5% by mass. Water- The water used for the preparation of the mortar shall not contain substances deleterious to the mortar nor to the water it is eventually intended to transport in the pipe. The presence of solid mineral particles is, however, admissible provided that these requirements are still fulfilled.

#### **Mortar**

The mortar of the lining shall be composed of cement, sand and water. Additives, may be used, provided that they do not prejudice the quality of the coating and that of the transported water. The mortar shall be thoroughly mixed and shall have a consistency which results in a dense and homogenous lining. The mortar shall contain by mass at least one part of cement to 3.5 parts of sand.

#### **Bituminous Coating**

Coating shall not be applied to any pipe unless its surfaces are clean, dry and free from rust. The coating material shall set rapidly with good adherence and shall not scale off. The mean thickness of the coating shall be not less than 70 µm and the local. Minimum thickness shall be not less than 50 µm. Where the coating material has a bitumen base, it shall be smooth and

tenacious and hard enough penknife. When the pipes to be used for conveying potable water the inside coating shall not contain any constituent soluble in such water or any ingredient which could impart any taste or whatsoever to the potable water after sterilization and suitable washing of the mains. Pipes with or without sockets and flanges which are imperfectly coated or where the coating does not set or conform to the required quality, the coating shall be removed and the pipes/flanges recoated.

**Hydrostatic site test pressures and hydraulic working pressure.**

Hydrostatic site test pressures and hydraulic working pressure of the newly laid pipe line is specified as under:

Refer Amendment No.1, (Annex E -Table 1) : IS 8329-2000

DN	Allowable operating pressure(excluding surge) AOP		Allowable Maximum Operating pressure (Including surge) MOP		Allowable site testPressure (STP)	
	K7	K9	K7	K9	K7	K9
	MPa		MPa		MPa	
80	0.8	6.4	1.25	7.7	1.75	9.6
100	0.8	6.4	1.25	7.7	1.75	9.6
125	0.8	6.4	1.25	7.7	1.75	9.6
150	0.8	6.4	1.25	7.7	1.75	9.6
200	0.8	6.2	1.25	7.4	1.75	7.9
250	0.8	5.4	1.25	6.5	1.75	7
300	0.8	4.9	1.25	5.9	1.75	6.4
350	0.8	4.5	1.25	5.4	1.75	5.9
400	0.8	4.2	1.25	5.1	1.75	5.6
450	0.8	4	1.25	4.8	1.75	5.3
500	0.8	3.8	1.25	4.6	1.75	5.1
600	0.8	3.6	1.25	4.3	1.75	4.8
700	0.8	3.4	1.25	4.1	1.75	4.6
750	0.8	3.3	1.25	3.9	1.75	4.4
800	1	3.2	1.5	3.8	2	4.3
900	1	3.1	1.5	3.7	2	4.2
1000	1	3	1.5	3.6	2	4.1

**Fittings**

Dimensional and other requirement for fittings for specified Diameter shall conform to the details given in tables 15 to 31 section 3 of the IS specification code IS: 9523: 2000.

Restrained joint DI pipes and fittings shall be used at bends, Tees, reducers etc or with restricted accessibility or in case of heavy thrust forces or as directed by Engineer-in-Charge.

#### Hydrostatic Test

For hydrostatic test, the fittings shall be kept under pressure for 10 seconds. They shall withstand the pressure test without showing any sign of leakage, sweating or other defect of any kind. The test shall be conducted before the application of surface coating. The fittings shall withstand the hydrostatic pressure given in table.

(Refer Table No. 2 IS 9523-2000)

Nominal DiameterDN (mm)	Hydrostatic Test Pressureat works, MPa
Up to and including 300	2.5
Over 300 and up to and including 600	1.6
Over 600 and up to and including 2000	1.0

The tolerance on dimensions of barrel and socket for push-on-joint fittings shall be as given in table

(Refer Table No. 3 IS 9523-2000)

Nominal Diameter	External Diameter DE		Wall Thickness mm		
	Nominal	Tolerance	K12	K14	Tolerance
DN	(2)	(3)	(4)	(5)	(6)
(1)	(2)	(3)	(4)	(5)	(6)
80	98	+1/-2.7	7.0	8.1	-2.4
100	118	+1/-2.8	7.2	8.4	-2.4
125	144	+1/-2.8	7.5	8.7	-2.4
150	170	+1/-2.9	7.8	9.1	-2.5
200	222	+1/-3.0	8.4	9.5	-2.5
250	274	+1/-3.1	9.0	10.5	-2.6
300	326	+1/-3.3	9.6	11.2	-2.6
350	378	+1/-3.4	10.2	11.9	-2.7
400	429	+1/-3.5	10.8	12.6	-2.7
450	480	+1/-3.6	11.4	13.3	-2.8
500	532	+1/-3.8	12.0	14.0	-2.8
600	635	+1/-4.0	13.2	15.4	-2.9
700	738	+1/-4.3	14.4	16.8	-3.0
750	790	+1/-4.4	15.0	17.5	-3.1
800	842	+1/-4.5	15.6	18.2	-3.1
900	945	+1/-4.8	16.8	19.6	-3.2
1000	1048	+1/-5.0	18.0	21.0	-3.3

#### Dimensions of standard Flange Drilling for Flange Fittings

(Refer Table No. 4 IS 9523-2000) (in mm)

Nominal Diameter	Dimensions of flange		Holes	Dia of Holes	Bolt Size, Metric
	DN	D (outer dia)	b (Thickness)	No.	
(1)	(2)	(5)	(7)	(8)	(9)
80	200	16	4	19	M16
100	220	16	8	19	M16
125	250	16	8	19	M16
150	285	16	8	23	M20
200	340	17	8	23	M20
250	395	19	12	23	M20
300	445	20.5	12	23	M20
350	505	20.5	16	23	M20
400	565	20.5	16	28	M24
450	615	21	20	28	M24
500	670	22.5	20	28	M24
600	780	25	20	31	M27
700	895	27.5	24	31	M27
750	960	29	24	31	M27
800	1015	30	24	34	M30
900	1115	32.5	28	34	M30
1000	1230	35	28	37	M33

**Dimensions of standard Flange Drilling for flange fittings PN 16**  
(Refer Table No. 5 IS 9523-2000) (in mm)

Nominal Diameter	Outer Diameter	Holes		Bolt Size, Metric
		No.	Dia (d)	
DN	D	No.	Dia (d)	
(1)	(2)	(3)	(4)	(5)
80	200	8	19	M16
100	220	8	19	M16
125	250	8	19	M16
150	285	8	23	M20
200	340	12	23	M20
250	400	12	28	M24
300	455	12	28	M24
350	520	16	28	M24
400	580	16	31	M27
450	640	20	31	M27
500	715	20	34	M30

600	840	20	37	M33
700	910	24	37	M33
750	970	24	37	M33
800	1025	24	40	M36
900	1125	28	40	M36
1000	1255	28	43	M39

The permissible deviations on the lengths of fittings shall be as under Deviation on Lengths of Fittings

#### Lengths of Fittings

(Refer Table No. 14 IS 9523-2000)

Types of fittings	Nominal diameter DN mm	Deviation in L&H mm
Flange socket, Flanged Spigot, Collars, tapers	80 to 1200	±25
Tees	80 to 1200	± 50/-25
Bends 90° (1/4)	80 to 2000	± (15 + 0.03 DN)
Bends 45° (1/8)	80 to 2000	± (10 + 0.025 DN)
Bends 20° (30) and 11° (15)	80 to 1200	± (10 + 0.02 DN)

#### Marking

Each fittings shall have as cast, stamped or indelibly painted on it, the following appropriate marks.

- (a) Indication of the source of manufacture.
- (b) The nominal diameter
- (c) The last two digits of the year of manufacture.
- (d) PN rating of flanges when applicable, and
- (e) Any other mark required by the purchaser.

Marking may be done on the barrel of castings or on the outside of the sockets. BIS Certification Marking

The fittings may also be marked with the Standard Mark.

The use of the Standard Mark is governed by the provisions of the Bureau of Indian Standards Act, 1986 and the Rules and Regulations made there under. The details of conditions under which the license for the use of the Standard Mark may be granted to manufacturers or producers may be obtained from the Bureau of Indian Standards.

#### **1.4.7.4.2 Specification for Laying and jointing of DI Pipes**

Code of practice for use and laying of DI Pipes should be as per IS 12288:1987.

##### **Preparatory work**

The contractor will inspect the route along which the pipe line is proposed to be laid. He should observe/find out the existing underground utilities/construction and propose an alignment along which the pipeline is to be laid. He should make all efforts to keep the pipe as straight as possible with the help of ranging rods. Wherever there is need for deviation, it should be done with the use for necessary specials or by deflection in pipe joints.

##### **Alignment and the L-sections**

The alignment as proposed should be marked on ground with a line of white chalk and got approved from engineer In charge. The contractor will than prepare an L-Section along this alignment showing the location of proposed pipe line. The L-section should also be got approved from the site Engineer. The position of fittings, valves, shall be shown on the plan. The alignments-section (depth of laying) and location of specials, valves and chambers may be changed at site in co-operation with and after approval of the Engineer in charge.

##### **Transportation of pipes and specials:**

The contractor has to transport the pipes and other materials form supplier to the site of laying as indicated by the engineer in charge. Pipes should be handled with care to avoid damage to the surface, internal lining and the socket and spigot ends, deformation or bending. Pipes shall not be dragged alongthe ground or the loading end of a vehicle. Pipes shall be transported on flat bed vehicles/trailers. The bed shall be smooth and free from any sharp objects. The pipes shall rests uniformly on the vehicle bed in their entire length during transportation. Pipes shall be loaded and un-loaded manually or by suitable mechanical means without causing any damage. Cranes or chain pulley block or other suitable handlingand lifting equipment shall be used for loading and un-loading of heavy pipes. However, for pipes up to 400 mm nominal bore, skid timbers and ropes may be used. Where using crane hooks at sockets and spigot ends hooks shall be broad and protected by rubber or similar material, in order to avoid damage to pipe ends and lining. Damage to lining must be repaired before pipe laying. Pipes shall not bethrown directly on theground.

##### **Bedding of the pipe**

The pipe shall be laid out along the proposed alignment in such a manner that they do not create any problem to public and are not damaged. The trench bottom shall be even and smooth so as to provide a proper support for the pipe over its entire length, and shall be free from stones, lumps, roots and other hard objects that may endure the pipe or coating. Holes

shall be dug in the trench bottom to accommodate sockets so as to ensure continuous contact between the trench and the entire pipe barrel between socket holes.

#### **Laying and jointing of DI pipes**

Pipes should be lowered into the trench with tackle suitable for the weight of pipes. For smaller sizes, up to 200 mm nominal bore, the pipe may be lowered by the use of ropes but for heavier pipes suitable mechanical equipment have to be used. All construction debris should be cleared from the inside of the pipes either before or just after a joint is made. This is done by passing a pull-through in the pipe, or by hand, depending on the size of the pipe. All persons should vacate any section of trench into which the pipe is being lowered. On gradients of 1: 15 or steeper, precautions should be taken to ensure that the spigot of the pipe being laid does not move into or out of the socket of the laid pipe during the jointing operations. As soon as the joint assembly has been completed, the pipe should be held firmly in position, while trench is back filled over the barrel of the pipe. The designed anchorage shall be provided to resist the thrusts developed by internal pressure at bends, tees, etc. Where a pipeline crosses a watercourse, the design and method of construction should take into account the characteristics of the watercourse to ascertain the nature of bed, scour levels, maximum velocities, high flood levels, seasonal variation, etc. which effect the design and laying of pipeline. The socket and spigot end of the pipes shall be brushed and cleaned. The chamfered surface and the end of the spigot end has to be coated with a suitable lubricant recommended by the manufacturer of the pipes. Oil, petroleum bound oils, grease or other material which may damage the rubber gasket shall not be used as lubricant. The rubber gasket shall be inserted into the cleaned groove of the socket. It has to be checked for correct positioning. The rubber gaskets shall be kept in their original packing and stored in cool conditions/not exposed to the direct sunlight should only be taken out when needed. The two pipe shall be aligned properly in the pipe trench and the spigot end shall be pushed axially into the socket either manually or with a suitable tool specially designed for the reassembly of pipes and as recommended by the manufacturer. The spigot has to be inserted up to the insertion mark on the pipe spigot. After insertion, the correct position of the socket has to be tested with a feeler blade. Deflection of the pipes if-any-shall be made only after they have fully been assembled. The deflection shall not exceed 75% of the values indicated by the pipe manufacturer.

#### **Joints**

In the case of push-on with or without centering rings the lengths of the spigot necessary for jointing shall not be less than the length of the socket of the jointing pipe. In case of push-on-joint the spigot end of fitting, if any, shall be suitably chamfered to facilitate smooth entry of spigot in the socket of the pipes or fittings fitted with rubber gasket. In case of flange and mechanical joint casting, the flange shall be at right angle to the axis of the joint. The bolt holes shall be either cored or drilled. The centre of bolt holes circle shall be concentric with the bore circle and shall be located of the centre line. Unless otherwise specified by the purchaser. Where there are two or more flanges, the bolt holes shall be correctly aligned between them. For high pressure mains, requiring working pressure greater than

1.8 Mpa, suitable flexible joint may be preferred where the joint is restrained against axial movement. Push-on-joint fittings are normally not used for sizes above DN 1600.

#### **Rubber Gaskets**

The material of rubber gaskets for use with mechanical joints and push-on-joints shall conform to IS: 5382. Unless otherwise agreed between the manufacturer and the purchaser. Dimensions of the rubber gasket shall be as per IS.

#### **Anchoring of the pipeline:**

Thrust block shall be provided at each bend, tee, taper, end piece to prevent undue movements of the pipeline under pressure. They shall be constructed as per design of engineer-in-charge according to the highest pressure during operation or testing of the pipes, the safe bearing pressure of the surrounding soil and the friction coefficient of the soil.

#### **1.4.7.5 Hydraulic Test**

1. DI pipes and Fittings
2. All the Pipes, specials and fitting of DI shall be supplied and tested as per relevant IS codes and specifications
3. The following code shall be used for
  - a. Factory Test Pressure: as per IS 8329
  - b. Site Test Pressure: as per IS 8329
  - c. Leak tightness test (Type Test) as per ISO 2531/BSEN 545

Suitable section as directed by the Engineer in charge shall be taken for such testing from time to time during progress of the work and satisfactory test given for that section. All testing apparatus, gauges, connections, etc. and water required for testing shall be arranged by the contractor at his cost. If there is delay in testing, the contractor shall refill the trenches for the time being and reopen them at time of testing at his own cost. If the trenches are filled due to any reason whatsoever before testing, the contractor shall have to open them for testing at no extra cost.

- A. Satisfactory hydraulic test shall be recorded when the section under test shall withstand the pressure as specified by the Engineer in charge for about 15 minutes without operating the test pump. The test pressure being maintained at the specified figures during that 15 minutes interval.
- B. The field test pressure to be imposed should be not less than the maximum of following.
  - i. 1.5 times the maximum sustained operating pressure.
  - ii. 1.5 times the maximum static pressure in the pipe line
  - iii. Sum of maximum sustained operating pressure and maximum surge pressure.

- iv. Sum of maximum pipe line static pressure and maximum surge pressure,
- C. Subject to the maximum equal to the work test pressure to any pipe fitting incorporation.
- i. During testing if any joints are found leaking they shall be repaired and / or redone by the contractor at his cost till the test is found satisfactory.
  - ii. Any pipes collars, specials, show hair cracks, leaks etc. during testing the contractor shall replace them with sound pipes and specials etc. free of cost.

During testing if any joints are found leaking they shall be repaired and / or redone by the contractor at his cost till the test is found satisfactory. Similarly, any pipes collars, specials, show hair cracks, leaks etc. during testing the contractor shall replace them with sound pipes and specials etc. The hydraulic test shall be given in presence of the Engineer in Charge.

### **Measurement**

All pipes shall be measured according to the work actually done and no allowance will be made for any waste in cutting to the exact length required. The net length of pipes as laid or fixed should be measured in running meters correct to a cm.

### **1.5.0 SLUICE VALVES**

#### **Sluice Valves & Other Accessories**

The details and specifications of Sluice valves to be used in pipeline system are as under. All tests shall be carried out as per the BIS standard. **All Sluice Valves up to 600 mm shall be of Glandless design**, generally conform to provisions of IS 14846 / BS EN 1171 / BS 5163.

#### **General Operational Torque Requirement of valves in manual operation**

All the sluice valves installed shall be manually operated but Sluice Valves of size 350 mm and above shall be provided with ball thrust bearings and suitable gearbox arrangement. Suitable operating handle shall be provided. Operation must be possible by one man against maximum design working pressure as per HGL. Nominal Pressure rating will be PN 1.0 unless otherwise specified.

#### **Flanges**

The flange drilling for all flanges shall conform to the provisions of IS 1538 / BS EN 1092 – 2 (Table 9). No new or additional holes shall be drilled on site.

#### **Gaskets & Packings**

Gaskets shall be of Nitrile rubber and readymade matching with respective flanges. Gasket cut out from rubber sheets are not acceptable.

#### **Manufacturer's Requirement**

The Sluice Valves shall be conforming to following specifications:-

#### **Materials of Construction**

Body, Door, Dome / Bonnet : DI IS 1865 Gr. 400/15 / DIN GGG  
40Wedge / Door : DI IS 1865 Gr. 400/15 / DIN GGG  
40

(upto 300mm the Wedge shall be fully vulcanized with EPDMrubber)

Body Seat / Door face : Gun Metals IS 318 Gr. LTB 2 (for 350 mm and above)  
Hand Wheel : DI upto 300 (above Steel Fabricated for gear box)

Stem : Stainless Steel AISI 420 (13% Cr) / 410

Stem Seal : EPDM

Lead Screws : Stainless Steel (ASTM A194 Grade 304)

Gasket : Nitrile Rubber / EPDM

### **Coating**

All resilient seated sluice valves shall be powder coated inside out; min DFT 250 microns; Shade RAL 5005 (Blue). All metal seated sluice valve (3500 mm and above) shall be liquid epoxy coated; min DFT250 microns; Shade RAL 5005 (Blue).

### **Gear Box for Valves**

**Multi Turn GearBox for Sluice Valve** (for 350 mm and above valves):

The rated torque capability of each operator shall be sufficient to seat, unseat and rigidly hold in only intermediate position the sluice valve door it controls under the operating conditions specified. Operator base is to be drilled as per ISO 5210 keeping in mind the rated torque of selected operator. The operator could be of spur type to ensure that the effort on hand wheel (dia. Not exceeding 750 mm) is limited to 80N pull and push, unless stated otherwise in the valve specification. The housing for the gearing must be enclosed and sealed in such a way that there is no leakage of oil/grease even after long period of in use and there is no ingress of rain water. Operator for valves which are likely to be submerged in water for long period during the rainy season, must be water tight. Min. IP 54 protection is a must. The hand wheels may be provided with extension and a plastic cover for easy grip. Alternatively they may be powder coated with a mat finish. The hand wheels must have a provision for locking with chain and pad lock. All operators when fitted to the valve shaft must ensure clockwise closing and this must be indicated on the housing / hand wheel. A mechanical indicator is to be provided to show door travel and end of travel. Valve manufacturer to ensure that a protective thrust plate is provided between the valve and the gear operator so that no lateral thrust comes on the gearbox.

### **Material of Construction:**

Housing and Cover : CI IS 210 Gr. FG 200

Spur Gears : EN-8 with hardened pinions of EN-19

Bearings :  
FAG/SKF/Equivalent“O” rings (if applicable)  
: Nitrile rubber

Hand wheel : Steel (fabricated)

Preferred make for Gear Box : AUMA / MASTERGEAR INDIA / EMERSON

### 1.6.0 AIR VALVES

Each Dual chamber air valve within built sluice valve shall be provided. Air Valve shall be capable of exhausting air from a pipeline when it is being filled with water. Air shall be released at a sufficiently high rate to prevent the restriction of the inflow rate. Similarly the valve shall be capable of ventilating pipeline automatically when it is being emptied. The air inflow rate should be sufficiently high to prevent the development of vacuum within the pipeline. The valve shall automatically release air accumulating in the pipeline during normal operating conditions.

Air valves shall be double acting type. For double acting type valves, a buoyant rigid ball (float) shall seal the large orifice and the chamber housing shall be designed to avoid premature closing of the valve by the air being discharged. A buoyant ball shall seal the small orifice at all pressures above atmospheric except when air accumulates in the valve chamber. All air valves shall be provided with an inbuilt valve and a flanged end connection.

The aperture of each valve must be properly designed for the proper air release and inlet rates.

All branched outlets including air valve tees shall be provided with one ½” BSP tapped coupling duly plugged for measurement of pressure. The closing plug shall be in Stainless Steel (AISI 304 or equivalent) with a hexagonal head. The head shall be provided with a copper washer for sealing.

Pressure rating of the air valves shall be PN 10 (10 kg/cm<sup>2</sup> operating pressure). The valves shall be

conforming to IS 14845.

The materials of construction for Air Valves shall be in accordance with,

Item	Material
Body, Cover and Cowl	CI IS 210 Grade FG 260
High Pressure Orifice and Plug	Bronze or Stainless Steel
Bush	Bronze
High Pressure Ball	Rubber
Low Pressure Ball	Vulcanite
Low Pressure Seat Ring	Nitrile Rubber

The valve locations should be critically analysed in lieu of the distribution network and finalised. The high elevation points and the air accumulation areas as per the fluid hydraulics need to be chosen and the air valve shall be installed. The pipe locations should be chosen as this asset need to be in chamber and a continuous maintenance is necessary. The suitable specials shall be supplied along with the valve to install in the distribution and transmission pipes.

#### **Dismantling Joint**

D.I dismantling joints shall be installed in such a manner that valves can be dismantled without stress to the joints. Dismantling joints shall be suitable for installation with all valves of different diameters. The dismantling joint shall be designed for a hydrostatic pressure of 16 kg/sq.cm. The sliding flange shall be machined smooth and shall slide at least 30 mm to disengage fully mating flange. All the fasteners for the dismantling joint shall be of SS 304. These shall be completely leak proof with proper gasket arrangement. Flange dimensions shall conform to latest relevant IS code. Flanged specials shall be supplied with required nuts, bolts and rubber gaskets. The dismantling joint shall be internally and externally coated with hot applied (dip) bituminous paint.

#### **1.7.0 M.S. SPECIALS AND GAP PIECES**

M.S. specials like Tee & Bends and gap pieces would be fabricated from M.S. plates of minimum thickness 10 mm by electric arc welding. The welded steel gap pieces and specials shall conform to IS : 3589- 1981. All M.S. specials and gap pieces shall be duly lined and out coated with 1: 3 Cement, Coarse sand mortar after fixing of S.W.G 25x25 duly approved by engineer Some of the important specifications for the same would be as below :

##### **i) Materials**

The mild steel plates used for fabrication of specials and gap pieces shall conform to IS : 226-1975 and IS : 2062- 1984. The welding electrodes used would conform to IS : 814 (Part-II) 1974.

The M.S. gap pieces and specials shall be required to withstand an internal test pressure of 16 kg/cm<sup>2</sup> and external pressure caused due to overburden according to varying depths in various reaches as per L-Section and other stresses caused during fabrication, handling, deformation when not under pressure, stresses due to self weight, stresses due to the weight of water and its tractive forces etc. and their various combination.

##### **ii) Manufacture**

The M.S. specials and gap pieces would be fabricated as per provisions made in IS : 3589-1981.They would be fabricated by electric arc welding, to be carried out in accordance with provisions made in IS

: 816-1969. Necessary anti-corrosive coatings on external and internal surfaces of the M.S. specials and gap pieces would be provided by lining and out coating with concrete or cement

mortar of suitable mix so as to make it impervious using mesh reinforcement. All other exposed metallic surfaces including nuts, bolts etc. would be rendered anticorrosive by application of anticorrosive paints. Dimensions of specials would conform to the specifications given for C.I. specials in IS : 1538 (Parts I to XXIII)- 1976.

**iii) Tests**

The ladle, analysis of the steel used in M.S. specials and gap pieces when made in accordance with IS : 228 (Part III)- 1972 and IS : 228 (Part-IX)- 1975, shall not show sulphur and phosphorous in amounts exceeding 0.06 percent each.

The welded joints shall be tested in accordance with procedure laid down in IS : 3600 (Part-I)- 1973. One test specimen taken from at least one field joint out of any ten shall be subjected to test.

**iv) Workmanship**

The specials and gap pieces shall be clearly finished and reasonably free from scale. They shall be reasonably straight free from cracks, surface flaws, laminations and other defects.

**1.8.0 EPOXY COATING**

Wherever the lining and out coating of M.S. gap pieces and specials is rendered difficult due to practical problems that part of gap pieces and specials should be duly coated with epoxy as per the following details:

**General**

Epoxy coating is to be applied to the external & internal surface M.S. Pipe / bend. The thickness of epoxy film shall be 600 microns.

**Materials**

A solvent free epoxy coating likes "Araldite GY 255 manufactured by Hindustan CIBA Geigy Ltd. Bombay or equivalent is to be used for forming the film. In case of use of an equivalent it should be got approved by the Engineer before placing supply orders.

Materials used and process of application to the concrete of other surfaces should be strictly according to the instructions of the supplier of the epoxy.

Araldite GY 255 one part by weight is to be mixed with 1 part by weight of Hardener HY 45. Subsurface Preparation

The mild steel parts are to be cleaned to be free of grease and thoroughly sand blasted. The coverage should not be more than 4 sq. meters for concrete and 3 sq. meters for mild steel per kg. PF epoxy respectively.

**1.9.0 HOUSE SERVICE CONNECTION**

One Service connection means one tapping from a distribution main/sub- main including one Electro- fusion saddles, double compression elbow, female threaded adapter/male threaded adapter with metal insert, HDPE to metal pipe connector, UPVC/metal lockable ball valve,

and HDPE/GI service pipe from tapping point to the chamber to inside the property as per the direction with U-ball valve. Only Bar coded electro-fusion machine (Automatically Readable) that can read the bar code of the fittings automatically shall be used for jointing of HDPE pipe / fittings. Manual feeding electro-fusion machines are not acceptable for jointing purpose.

Providing required size of HSC electro-fusion tapping saddle confirming to relevant IS make hole by using tapping tee cutter provided on the top of tapping saddle on top of distribution mains, fixing the electro-fusion saddle making the connection water tight etc., as shown in the drawing include labour required for excavation, fitting, refilling, closing water supply in that area, dewatering and restarting the water supply, transportation etc complete as directed by Engineer-in-Charge and as directed by the Engineer including cost of required specials, Electro-fusion machine, power/generator required for electro fusion, hydraulic testing, maintaining the same for the period under O&M.

### **Connection to Consumers**

All service pipes and fittings from the connection on the water main to any premises shall be laid by the Contractor as per specifications and the approved drawings the connection pipe shall be laid in the ground and shall not be less than 60 cm below the surface. All pipes shall be laid or fixed in such a manner as not to be exposed to the heat and not to cause any damage to any consumer's pipes and fitting and there should not be any risk of mixing waste water or cause contamination of water. The material of the pipes and fittings shall be got approved from the Engineer-in-charge before use. The position of the stopcock on the connection pipe shall be as per approved drawing. All cocks and taps fitted to the service pipes in any premises shall be of a screw down lockable pattern and of quality approved.

No pipe used for the conveyance of water shall be laid or fixed which shall run through any drain or any place where water through such pipes is liable to become polluted or contaminated or where the pipe is likely to get damaged. However, in unavoidable cases such consumer's pipe may pass through an exterior air tight and water tight pipe or jacket of G.I pipe or other material approved by the Executive Engineer of sufficient length and strength and of such construction as would provide adequate protection to the inner pipes.

Every premises supplied with water shall have its own specific connection pipe and no connection pipe shall be used to supply water to more than one premises.

The position of stop cock on the connection pipe shall be decided as per approved HSC drawing who shall have exclusive control over this stop cock and its operation.

The leakages upto the stop cock or up to the meter without stopcock shall be removed by contractor at his cost.

At every road crossing the contractor need to lay HDPE pipe under the casing pipe G.I of 40 mm Dia. No extra cost will be paid for this.

### **Excavation & Refilling for House Service Connection**

The specification of excavation written in this chapter shall be applicable for excavation and refilling of house service connection.

## **Material**

### **Saddles For Making Connection with HDPE mains:**

All saddles shall be injection moulded from recognised top quality virgin PE 100 resin.

1. All saddles must conform to the requirements of EN 1555-3 / EN12201-3 and be suitable to be used in conjunction with pressure pipes from polyethylene manufactured to the appropriate ISO and CEN standards & approvals of either of internationally recognised authorities, such as KIWA/ DVGW/SVGW/ Gas de France/ Gastec etc. for their products.
2. Each carton or protective package must clearly indicate its contents.
3. The heating coils contained in each individual saddle should be so designed that only one complete process cycle is necessary to fully electro-fuse the fitting to the adjoining pipe or pipeline component as applicable.
4. No heating element may be exposed and all coils are to be fully imbedded into the body of the fitting for protection purposes.
5. The pipe fixation device shall be an integral part of the body for all saddles in the sizes up to and including 250mm.
6. An individual barcode compliance with ISO 7810 and ISO 7811 containing setting information for data transfer purposes must be supplied with each fitting. The barcode must also contain a traceability barcode. This barcode must contain the following information about the product: batch number, production facility, the manufacturer of the raw material, the MRS and the MFI.
7. All fittings must have moulded-in identification and appropriate product information.
8. Process voltage of all saddles must not exceed a maximum of 40 volts.
9. Insulated contact heads for the terminal pins are to be provided.
10. Terminal pin size shall be 4.0 or 4.7mm in diameter.
11. A limited path style fusion indicator acting for each fusion zone as visual recognition of completed fusion cycle should be incorporated into the body of the saddle near or adjacent to the terminal.
12. The design of the fusion indicators must prevent the escape of fusion melt.
13. All saddles up to mains size nominal diameter 250 mm should be designed with two separate halves having a self-tapping screw attachment and are to be correctly processed without specialised external spring-loaded tooling. The bottom half, the clamp, shall also be made of PE100.
14. The branch spigot of tapping tees must be long enough to allow a second joint if necessary or to attach a compression fitting.
15. Safe tapping into mains must be possible under the defined allowable maximum water pressure according to the respective pipe series and ambient temperature.
16. The tapping saddle cutter is to be designed to seal-off the central passageway in the uppermost position.
17. The cutter design must fully contain the cut-out coupon and not produce shavings
18. The outer neck of the saddle shall be provided with a rubber-sealing ring.
19. Upper cap must have the tri-locking system with proper rubber- sealing ring.
20. Special tools shall be available from the manufacturer to provide a leak-free tapping.

- The outlet on the branch of the saddle must allow the integration of a water-stop.

## Saddles For DI Pipe

### Saddle for making house service connection with DI/CI mains.

#### General specification:

- Strap saddles** shall be suitable for CI/DI pipes with nominal outlet connection size of 20 mm BSP female thread. The body shall be Resicoat® epoxy coated with thickness of 250 micron as per GSK standard & EN14901. The saddles shall be single type upto pipe sizes of NB 300 and service outlet of 20 mm BSP female thread. Fasteners shall be of threaded nut-bolt-washer type. Nut-bolts of size 1/2" (M12) shall be used. Saddle strap shall be with NBR protection rubber. The sealing between the saddle and mains shall be obtained by using a profiled elastomeric seal matching to the curvature of the pipe. The seal shall be of NBR elastomeric type, suitable for all potable water applications. Maximum working pressures up to 16 bars Material and Design Specifications
- Saddle body** (Improved version design for 1/2", 3/4" BSP female thread):  
DI GGG40 with Resicoat® epoxy (for corrosion protection of fittings) coating with length 172 mm, width 60 mm, height 40 mm & thread depth 22 mm. The body shall have retaining cavity housing for internal and external retention of the elastomeric seal. Sealing shall be achieved by pressure exerted by the body while fastening the saddle straps & body on the pipe.
- Saddle straps** shall be made of stainless steel 304 grade, gauge 16 & width 40mm to prevent corrosion over the long service life & should be with no weld joint to avoid inconsistency of strength.
- Strap Protection Rubber:** NBR UV protected Elastomeric (rubber) shall be such that none of the Stainless Steel Strap is in direct contact with the pipe. It shall ensure a firm non slip grip mounting on the pipe due to external loading.
- Saddle seal:** It shall be virgin rubber NBR Class 70 complying with EN 682-2002. It shall be of type pressure activated hydro-mechanical design. It shall be contoured gasket to provide a positive initial seal which increases with increase in the line pressure. Gasket shall be, with the outlet section having o-ring contacting the saddle body.
- Nuts & Bolts- Washer:** Stainless Steel Type 304, NC rolled thread, Tightening torque for 1/2" (M12) nut-bolt: 14-15 kg m.

The pipes shall be manufactured from high-density polyethylene, containing only those antioxidants, UV stabilizers and pigments necessary for the manufacture of potable water black pipes. They shall comply with ISO/DP 4427/. The Contractor shall provide an approved third party certificate to verify the above. Reworked material, generated from manufacturer's own production of pipes, shall not be used. Detail of materials to be used in House Connection Work shall be as follows

Dia of distribution Pipe line	Material for house connection		
	Types of Saddle	Pipe material shall be used	Other specials shall be required
110 mm to 160 mm HDPE	Electro fusion Monoline tapping saddle with bottom belt	HDPE PE100 PN12.5	Ferrule, Compression Fittings (MTA, FTA) G.I

200 mm to 500 mm DI	DI Strap Saddle	& GI Medium class	specials etc. Complete
---------------------	-----------------	-------------------	------------------------

**Ferrule Cocks:**

Ferrules for water services shall be as per IS 2692.

It should be a draw off appliance with a vertical inlet for screwing on to water main and a horizontal outlet.

Ferrules shall be standard screw down pattern brass ferrule with female BSP (British Standard Pipe) screwed single outlet with suitable thread for the purpose. It shall have a main stem with 360° swivel outlet at 90° with control of water flow via a threaded inner plug.

The ferrule shall be designed for underground installation, and to handle potable water with temperature up to 50°C, and also to withstand a working pressure of 30 kg/cm<sup>2</sup>. The design of ferrule shall permit the installation of service pipe by means of drilling and tapping machine, under pressure ordry, and with or without service saddles, into HDPE pipes and DI Pipes of different diameters.

Sl. No	Component	Material	Conforming to
1	Body, plug and cap	Leaded tin bronze	Grade LTB 2 of IS 318 : 1981
2	Washer plate and nut	Brass ( extruded, rolled, diecast )	Type I Half hard of cast, IS 319 : 1974 Grade DCB 2 of IS 1264 : 1989 HT 2 of IS 320 : 1980
		Leaded brass	Grade FLB of IS 6912 : 1985
3	Resilient washer	Leather Vulcanized fibre Rubber	IS 4346 : 1982
4	Copper washer	Copper	IS 3487 : 1966

The ingress of dirt shall be prevented by a polypropylene top plug. Every ferrule including the component parts should be hydraulically tested for PN 10 (10 bar) rating adopting the suitable test procedure and should ensure the leak free operation while installed.

IS 2692, source of manufacture and the nominal size in mm should be legibly marked in the body of each ferrule.

**Bolts, Nuts and washers:**

All bolts, nuts and washers unless specified should be made of carbon steel conforming to IS 1363:1963.

Testing: Every ferrule, complete with its component parts, shall withstand a hydraulic

pressure of at least 1.5 MPa, applied for two minutes, and during this period it shall neither leak nor sweat.

### **GI Pipes and Fittings**

#### Scope

This Specification covers the requirements for manufacturing, supplying, laying, jointing and testing at works and site of Galvanized Iron pipes used for water supply. The GI pipe is recommended to use only at above ground level or pipes exposed to sunlight and road crossing for the encasement of PE Pipe.

#### Applicable Codes

The laying GI pipes and fittings / specials shall comply with all currently applicable statutes, regulations, standards and Codes. In particular, the following standards, unless otherwise specified herein, shall be referred. In all cases, the latest revision of the standards / Codes shall be referred to. If requirements of this Specification conflict with the requirements of the standards / Codes, this Specification shall govern.

IS: 1239 (Part-I)	Specification for Medium Grade GI Pipes
IS: 1239 (Part-II)	MS Tubular or Wrought Steel Fittings for GI Pipes
IS: 4736	Specification for Galvanizing
IS: 554	Specifications for Pipe Threads of Screwed Tubes and Sockets

#### **Material of Ball Valve**

The UPVC/metal lockable ball valve (as approved by Engineer-in-charge) shall withstand a temperature of 50o C for outdoor installation with both ends having female threaded joints. These ball valves shall be suitable for installation in cold potable water supply system for human consumption. The head loss in the ball valve shall be minimum and the initial design of the ball valve shall be such that it causes least obstruction to the flow of water. With locking arrangement such that if any consumer found defaulter for non-payment using the ball valve we can disconnect the supply of such consumer. The UPVC/metal lockable ball valve (as approved by Engineer-in-charge) should be easy to operate with minimum torque being applied and it should be easy to dis-assemble the same and replace the damaged part and re-assemble easily.

The dimension of the UPVC/metal lockable ball valve shall be conforming to the best national/ISO/DIN/EEC standards and should not pose any problem for easy installation, maintenance and removal. All the parts of the UPVC/metal lockable ball valve shall be interchangeable for a given diameter.

The UPVC/metal lockable ball valve shall be designed, manufactured and tested for carrying cold potable water for human consumption and they shall be in black or in any approved colour which will be installed outdoor and shall one side with BSP parallel threads and the other side shall a compression fitting suitable for jointing PE pipe directly into UPVC/metal

lockable ball valve. The BSP parallel threaded ends shall be with female fittings to suit the BSP threaded male adopters. The UPVC/metal lockable ball valve shall meet all the relevant standards of the country's Health Ministry Regulations for carrying cold potable water for human consumption.

The materials of UPVC/metal lockable ball Valves shall be impact resistant and all housing components shall be made of Ultra Violet radiation protected Polyvinyl Chloride (UPVC), Poly Propylene (PP), Poly Vinyleiden Fluoride (PVDF) and the ball seat shall be of Poly Tetra Flour Ethylene (PTFE) and the seal ring shall be of Ethylene Propylene di Methyl (EPDM) or Fluor – Caoutchouc (FPM). The materials of the Ball Valves shall be subjected to long term thermal testing for determination of reaction time, specific gravity, Carbon mono Oxide (CO) content, ash content, column strength, resistance to extension, flexural strength and abrasion resistance. To determine the chemical resistance of thermoplastic materials, immersion tests to find the suitability for using the UPVC/metal lockable ball for carrying potable water for human consumption should be carried out.

The base materials used for making Ball Valves shall be certified by the Health Ministry of the country of origin of UPVC/metal lockable ball as fit for use in carrying potable water for human consumption. The bore shall be smooth with minimum friction and it should be strong to any chemical reaction and more particularly to free chlorine available in water. The material shall be non-toxic and free from metallic stabilizers, corrosion resistant and maintenance free. It should be resistant to heat and ultraviolet radiation and should be easy to handle, install and remove with high durability.

The UPVC/metal lockable ball shall have the following components like Union Nut, Ball, Body Stem, Handle, Hose Adopter Nut, Packing Pressure Bush, Quick Joint Nut all of Ultra Violet radiation Protected Polyvinyl Chloride (U PVC) and Clipping Ring of Poly Acetyl and Hose Adopter 'O' ring support, Ball Seal, O ring stem, Quick Joint O ring of either PP/POM/NBR/PE+PTFE material. All the materials used either internally or externally in the manufacture of Ball Valves shall be Ultra Violet(UV) stabilized, and shall conform to reputed national standards or ISO/DIN/EEC standards.

## **2.0 SPECIFICATIONS FOR CIVIL WORKS**

### **General**

The Contractors are advised to study the drawings understand the works carefully and inspect the site where these works are to be carried out to form a clear idea of the difficulties likely to be met with in procurement, transportation and stacking of materials or labour, execution of different items of works in close proximity of existing pipelines, trees on the alignments, telephone and electric poles, cables, sewer, drains, road, lanes etc. The Contractor should tender his rates considering all such difficulties as no extra claims whatsoever will be entertained later on.

#### **2.1.0 EXCAVATION**

The excavation for laying of pipe shall be carried out in accordance with B.I.S. detailed

specifications. The excavation shall be carried down to the depths as per duly approved L-Section and as required at site or as directed by the Engineer and shall be neatly executed. Where excavations are made in excess of the depths required as shown in the drawings or as directed by the Engineer-in-charge, the contractor shall at his own expense fill up to the required level with lean concrete or well compacted sand as decided by the Engineer-in-charge. Loose, soft or bad soil encountered in excavations at the required depth on Engineer-in-charge's direction shall be excavated to the firm bed and the difference of levels between the required level and the firm bed shall be filled up or dealt with as directed by the Engineer-in-charge. Earth work in excavation includes site-clearing activities like removal of shrubs, loose stones, rubbish of all kinds, interfering with the works and with complete removal of roots. The Contractor shall control the grading in the vicinity of all excavations so that the surface of the ground will be properly sloped to prevent surface water running into excavated areas during construction. Arrangements shall be made for preventing rain and other extraneous liquids entering the excavated parts. Seepage water shall be directed to flow away from the trenches by gravity. If any pumping is required to keep the trench and the exposed areas dry for further work the same shall be done. The contractor shall be solely responsible for the protection of adjoining properties from damages that may be on account of excavation close to the properties whether the property belongs to government or to a private party. A permanent bench mark or marks as required necessary for the works connected to the nearest bench mark shall be established for reference. All excavations shall be strictly done true to line, level, grade or slope. The Contractor shall undertake all responsibilities for slips or subsidence and shall make good all damages to any adjoining property or the existing pipeline at his own cost to the satisfaction of Engineer. The contractor shall make all arrangements for proper warning like providing fences, danger flags, barricading, night warning lights, watch and ward etc. to caution the public as well as the laborers engaged by him about the danger that may be involved by excavation of trenches, pits, foundations etc. Safety code for excavation work IS 3764-1966 shall be rigidly followed unless instructed otherwise by the Engineer-in-charge. The contractor shall be held liable to indemnify the Engineer for any damages done to adjoining property or to any of the work in progress or partially completed by any settlement of ground which, in the opinion of the Engineer, is attributable to any of the excavation, trench work, weak timbering or imperfect refilling done by the Contractor etc. included in this Contract, notwithstanding that any settlement may have been caused by the obstruction of any drain or sub-soil water during progress of works of pumping. The excavation shall include all slope trimming where required. Before starting any excavation the contractor will get the alignment of the centre line approved by the Engineer or Engineer's representative. The Contractor shall take care to surround the pipes generally to a depth of 100 cm. above the top of pipe or as per L-Section with selected earth. Large lumps of earth, boulders, stones or bricks shall not be thrown into the trenches in a manner as to damage the pipe. Any damage so occurred shall be made good by the Contractor at his own cost. The Contractor shall arrange, if so required, suitable earth for refilling the trench at his own cost. The trench shall be filled in 15cm. layers and each layer shall be watered and rammed. The rates accounted for the excavation should be comprehensive enough, to cover the watering charges as no dry filling of earth shall be permitted. All surplus earth shall be disposed off by

the Contractor to a suitable place as directed by Engineer-in-charge. The trenches shall be properly barricaded and fenced off wherever necessary. Red flags and caution boards during day and red lights during night shall be displayed so as to avoid any accidents. He shall provide all pumps and other appliances including all types of labour for rendering the trenches clear of any water that may find its way into it and shall duly account for the same in his rates as no extra claims for such contingencies will be entertained. He shall also be responsible to pay an compensation to any person subjected to injuries or death due to his negligence in providing necessary safety precautions. All findings found during the excavation such as antique relics, coins, fossils etc. shall be the Government property and will be immediately handed over to the owner. The contractor must allow sufficient margin in his rates to cover the cost of taking photographs of buildings which show cracks or defects before operations commence, the fixing of Tell Tales, registrations and other legal expenses in connection, with necessary precautions to be taken to avoid possible damage before trench work and excavations are started. The excavated earth shall be placed at 1.50 to 2.00 mts. distance from the sides of the trenches wherever possible to avoid surcharging of the sides of excavation and in a manner so as not to interfere with traffic access to houses and shops. At places where the above specified distance is not available then the Contractor will be required to keep the excavated earth along the road side paths, if available. In case of narrow and congested lanes and bye lanes the Contractor will be required to undertake work in small lengths of say 15 metres or 30 metres or as directed by the Engineer and in such cases, the excavated earth shall either be placed upon the line laid or on the portions under where the line is proposed to be laid. The Contractor in such cases will have to make his working methodical to avoid carting and keep extra lead, as minimum as possible. It may be noted clearly that no extra payment for double carting and extra lead shall be made to the Contractor. In case the excavated material is not suitable or falls short of requirement the back fill soil shall be taken from borrow pits approved by the Engineer-in-charge. The rates quoted by the contractor shall be deemed to be inclusive of all such works. The contractor shall also provide gang-ways for the convenience of pedestrians and occupants of the adjoining property and at least half of the road width will be left clear for the traffic. The closure of road or diversion of traffic shall not be allowed unless obligatory in the opinion of Engineer and all arrangements, correspondence, permission or related expenditure on this account shall be done by the Contractor at his own cost.

For excavation of depth upto 1.5 metres below ground level width of trench shall be measured as O.D of barrel of pipe + 60 cm, for depths between 1.5 m to 3.0 m below G.L offset of 25 cm. in both sides shall be measured for higher depth than 1.5 m. Likewise, for depths between 3.0 m to 4.5 m below G.L, offset of 25 cm. in both sides shall be measured for higher depth than 3.0 m, and so on. The excavation of trenches shall include excavation in filled up or under laid materials like kankar, brick bats and boulders etc. Whenever a pipe or cable or any other work has to cross a road or they have to be executed along a road and within the road width either in the center or on either sides of the road, the existing road surface shall be dug, spoil removed and stacked separately so as to reuse the usable material. The road surfaces shall be brought to their original shape and grades by making use of the

excavated material after back filling the trenches. Any public utility services / facilities like water supply lines sewers, telephone / electric cables poles etc., met with during excavations shall not be damaged and no disruption is caused to the utility service on account of damages caused by the contractor. Such facilities shall be properly supported in their original positions by giving suitable slings etc.

For getting necessary permissions, from various Government and Semi-Government Departments e.g. NHAI, Railways, U.P.P.W.D., U.P. Forest Department, U.P. Revenue Department, U.P. Irrigation Department for crossing of Railway lines, roads and felling of trees for laying of pipeline shall be obtained by the Employer. All expenses to be incurred in obtaining these permissions shall be borne by the Employer.

The Contractor shall arrange, by contracting concerned authorities of U.P.P.C.L , Urban Local Body and Telecommunication Department, for the shifting of electric and telephone poles, cables, water mains, sewer / drain pipes etc. falling alongside the alignment. The cost incurred by the contractor for shifting of these services shall be reimbursed to the contractor by the Employer upon production of proof of payment to the concerned authority.

Excavation whose sides are required to be maintained at a steeper slope than the stable slopes, will be required to be properly shored and strutted. Negligence on account of this leading to any mishap will be entirely the responsibility of the Contractor.

### **2.2.0 TIMBERING**

When the depth of foundation or pipe trench is great and the soil is soft and generally for depths more than 1.5 mtrs stepping, sloping and or paneling and strutting of sides shall be done as directed by the Engineer. **The decisions regarding the positions and depths at which and what type of paneling and strutting is to be provided shall be taken by the Engineer. The contractor shall not proceed until he has received approval from the Engineer-in-charge.** It shall be the responsibility of the contractor to take all necessary precautions or steps to prevent the sides of trenches from collapse. The contractor shall be responsible to make good any losses or damages caused to execute works, life and property due to his negligence. Deep excavations shall be inspected after every rain, storm, or other hazards and if necessary the precautions required shall be augmented. Planking and strutting shall be either "Close" or "Open" type depending upon the nature of the soil surcharge and depth of excavation etc. The timbering shall be of sufficient strength to resist earth pressure and ensure safety to the adjoining property and to persons. Where the excavations are subjected to vibrations due to machinery, vehicles, rail, traffic, blasting and other sources, additional bracing shall be provided. Generally the specifications and sizes and spacing of sheeting, walers and struts used for timbering of different depths shall be as given in the IS 3764 Safety code for excavation work unless otherwise specified in the tender elsewhere. Shoring shall extend 30 cm above the vertical sides. Withdrawal of timbering shall be done very carefully to prevent collapse of the sides of excavations and any damage to the work executed. Open timbering shall be provided wherever the Engineer directs, where the trenches are not close to any buildings / property / structures. In open timbering the trench shall be protected by covering 1/3 the surface area by planks. All trenches that are in close proximity of a building within 3 mtr. and are more than 1.5 mtr. deep shall be close timbered. In close timbering for depth upto 3 mtr. walers shall be at least of sizes 125mm x 75mm rectangular

section of sal or approved wood. The length of each waler shall be limited to 2.25 mtr. those that are positioned in vertical positions to 1.25 mtr. and they shall be strutted at 1.5 mtr. centre to centre with salballies having diameters of at least 100 mm or 1 cm per 30 cm length of strut whichever is greater. The polling boards shall be 40 mm thick sal or other approved wood not more than 20 cm wide and 2.25 mtr. in length. The polling boards shall be placed close together with plain butt joints. No boards, walers, or strut, which has been in any way injured or weakened state, shall be reused. For depth of trenches from 3 mtr. to 6 mtr. the sizes of walers shall be 150 mm x 75 mm rectangular section of sal or approved wood. The length of each waler shall be limited to 2.25 mtr. and they shall be strutted at 1.25 mtr. centre to centre, with salballies having their diameters of at least 125mm or 1cm per 30 cm length whichever is greater. The polling boards shall be 50 mm thick sal or other approved country wood not more than 20 cm wide and 2.25 mtr. in length. Other conditions shall be same as for depth upto 3 mtr.

### **2.3.0 LAYING & JOINTING OF PIPES**

#### **General**

The transportation of pipes from the stores to the site of works has to be done in such a way that pipes are not damaged while handling and during transportation. Light pipes and pipes of smaller diameter shall be handled manually. Heavy pipes shall be loaded and unloaded using lifting tackles like chain pulley blocks and shear legs. The pipes shall be protected against impact, shocks etc. Pipes shall not be allowed to fall freely on to the ground and hard surfaces so as to cause cracks in pipes. Transportation of pipes and stacking by the side of the trenches shall also be done in such a way that it causes minimum inconveniences to the traffic. The pipes shall be laid out along the side of the trenches, each pipe in its position for laying with an extra pipe after every 20 nos. When the trench crosses a road or place where such distribution is inadmissible, the pipes shall be stacked in piles at each end in sufficient numbers to fill in the length. Permanent benchmarks have to be established at convenient and frequent interval all along the pipe alignment for carrying the levels to the place of laying of the pipes. The lowering of pipes shall not be commenced until the Engineer has checked levels and permits the lowering of pipes. The pipes shall be checked for absence of cracks and damaged parts of pipe ends. The pipes shall also be cleaned to remove all dirt and soil and other foreign materials before lowering into the trenches. After jointing it shall be ensured that the extra jointing materials are removed. It shall also be ensured that no foreign material enters the pipes after they are laid by covering the pipe ends suitably. Normally the pipes are laid from downstream towards, upstream, the spigot end facing upwards. The spigot end shall be pushed home to the full depth of the socket. Lowering of the pipes into the trenches shall be done equally carefully so that the pipes are not damaged and also the trenches and bedding for pipes are not disturbed and damaged. Smaller and lighter pipes can be lowered using rope slings and shall not be dropped onto the trench bottom. Heavy pipes shall be lowered into the trenches by means of shear lags, chain pulley blocks and tackle. During the operation any pipe that is allowed to fall into the trench shall be condemned and removed from the site immediately. Care shall be taken while lowering the pipe into the trench. The Engineer-in-charge for damage examines each pipe which is laid in the trench. Cracked, broken in damaged pipes shall not be allowed to be used in the works. For any damage done due to the

negligence of the contractor, the contractor will have to replace the pipe free of cost.

Pipes should be lowered into the trench with tackle suitable for the weight of pipes, such as well designed shear slings with chain block or mobile crane. While lifting, the position of the sling should be checked when the pipe is just clear off the ground to ensure proper balance. Laying of pipes shall preferably be proceeded upgrade of a slope. When laying is not in progress, the open ends of the pipeline should be fitted with temporary end closure. This may make the pipe buoyant in the event of the trench becoming flooded and any movement of the pipes, should be prevented either by partial refilling of the trench or by temporary strutting. The pipes shall be prevented from floating in case pipe trenches being flooded by properly loading the pipes with back filling material. The pipes shall be laid in trenches where ever specified on concrete / sand bedding wherever required as per the direction of the Engineer. Trenches shall be kept free from water but in case the trench is liable to be flooded by rain, care shall be taken to prevent the pipes from floating and the water would be pumped out by the Contractor as early as possible. Walking or working on completed pipeline shall not be permitted until the trench has been back filled to a height of at least 30 cm. above the pipes. Tampering around the pipe shall be done by hand or other hand operated mechanical means. The water contents of the soil shall be as near to the optimum moisture content as possible. Filling of trenches shall be carried on simultaneously on both sides of the pipes in such a manner that unequal pressure does not occur.

#### **Jointing**

The individual pipes shall be jointed together. The sections of the pipe should be jointed together in such a manner that there shall be as little unevenness as possible along the inside of the pipe. Basic requirements for the joints are –

- a) Cleanliness of all parts, particularly joint surface
- b) Correct location of components
- c) Centralization of spigot within socket
- d) Provision of the correct gap between the end of the back of the socket to ensure flexibility at each joint ; and
- e) Any lubricant used shall be approved as to composition and method of application.

The jointing of the pipe shall be such that the rubber ring is to be placed on the spigot which is then forced into the socket of the pipe previously laid by applying a uniform compression to roll the rubber ring into the annular space between the two surfaces of the spigot and socket to form a flexible and water tight joint. Similarly, the special fittings shall also be jointed in a manner to form a water tight joint. If any damage is caused to the pipeline during the execution of work or while cleaning/testing the pipeline as specified, Contractor shall be held responsible for the same and shall replace the damaged pipeline and retest the same at his own cost to the full satisfaction of Engineer.

#### **2.4.0 FIXING OF VALVES**

Sluice, scour and air vales shall be fixed at proper places as indicated in the plan of alignment or as directed by the Engineer-in-charge, with required specials true to alignment and level.

Air Valves at the places shown in drawings or any other places as directed by the Engineer-in-charge shall be fixed to alignment by providing proper air valves tees.

Scour valves at proper places shown in drawing or as directed by the Engineer shall be provided true to alignment with the help of tees. Proper arrangements shall be made to dispose off the water in the nearby drains after providing proper chambers as specified to avoid unhygienic conditions likely to occur at the time of scouring.

#### **2.5.0 CONSTRUCTION OF CHAMBERS OF VALVES**

The valves shall be rested on 1:2:4 P.C.C. block underneath as required or directed by the Engineer to ensure adequate stability. All the sluice valves shall be covered by making suitable chambers as per drawing to give clear space for working. The chambers shall be covered with R.C.C. 1:1.5:3 slabs of proper sizes, capable of taking the traffic and other loads on them and providing manholes with covers at top in proper shape to afford access inside the chambers. The chamber and slab designs shall be provided by Contractor.

#### **2.6.0 THRUST BLOCKS**

In case of rising mains / pressure pipes, at changes of directions of pipes thrust blocks in RCC 1:1.5:3(M 20) with minimum reinforcement 5 kg/sqm to resist unbalanced forces shall be provided as indicated in the drawings to be submitted by contractor.

#### **2.7.0 BRICK MASONRY**

##### **Bricks**

Bricks used for the construction of brick masonry shall be sound, hard, and rectangular in shape and size and well burnt of uniform deep red, cherry or copper colour and shall conform to IS 1077. The bricks shall be brought from approved brick kilns. The bricks shall be free from cracks, chipping flaw, stones or lumps of any kind. The bricks shall not show any signs of efflorescence and shall be homogeneous in texture. They should emit a clear metallic sound on being struck and shall have a minimum compressive strength of 10 N/sq. mm equivalent to 100 kg/cm<sup>2</sup>.

They shall not absorb water more than specified in the Indian Standard Specifications, of its dry weight when soaked in cold water for 24 hours.

##### **Mortar**

The proportion of the cement mortar used for the masonry work shall be as specified on the various drawings for different places/ types of construction, specification for each part of the work.

For cement mortar cement shall be fresh Portland cement of grades 43 of ISI standard specification.

Sand shall be sharp, clean and free from organic and foreign matters. For rich mortar coarse or medium sand should be used and for weak mortar local fine sand may be used. Proportion of cement sand mortar may be 1:3 to 1:6 as specified.

Materials of mortar shall be measured to have the required proportion with measuring box and

first mixed dry to have a uniform colour in a clean masonry platform and then mixed by adding clean water slowly and gradually to have workable consistency and mixed thoroughly by turning at least three times. Fresh mixed mortar shall be used, old and stale mortar shall not be used and mortar for one hour work only shall be mixed with water so that the mortar may be used before setting starts.

Sharp coarse sand is mixed with the required quantity of cement for the preparation of the mortar. Mortar shall be prepared in accordance with IS 2250. The sand used for the masonry mortar shall meet the requirements as specified in IS 2116. Sand for masonry mortars. Sand and cement of required proportions are mixed in small quantities in a dry state first and then water is added to make the mortar of required consistency suitable for the type of work it is required as directed by the Engineer. No left over mortar shall be used and therefore only that much quantity of mortar that can be consumed within 30 minutes shall be mixed in batches.

### **Construction**

The brick masonry shall be constructed as per the Indian standard code or practice for Brick Work: IS –2212. The thickness of the joints shall not be thicker than those specified in para 5.4 of the above code of practice. The bricks shall be thoroughly soaked in water before using them on the work for at least six hours and all the air bubbles shall come out during soaking process. The soaked bricks shall be stacked on wooden planks/platforms so as to avoid sticking of the earth and other materials onto the surfaces of bricks. Brickwork shall be laid in English bond unless otherwise specified. Half bricks shall not be used except when needed to complete the bond. Each course shall be perfectly straight and horizontal. The masonry shall be true to plumb in case of vertical walls and in case of battered construction the batter or slope shall be truly maintained. The level of the course completed shall be checked at every one-metre interval or less as required. The bricks shall be laid frogs upwards. While laying the bricks they shall be thoroughly bedded and flushed in mortar and well tapped into position with wooden mallets and superfluous mortar shall be removed. No part of the structure shall be raised more than one meter above than the rest of the work. In case it is unavoidable the brick work shall be raked back at an angle of not more than 45 degrees so as to maintain a uniform and effectual bond, but raking shall not start within 60cms from a corner. At all junctions of walls the bricks at alternate courses shall be carried into each of the respective walls so as to thoroughly unite both the walls together. The brickwork shall not be raised more than 14 courses per day. All the beds and joints shall be normal to the pressures applied upon them i.e. horizontal in vertical walls, radial in arches and at right angles to the face in battered retaining walls. Vertical joints in alternate courses shall come directly one over the other and shall be truly vertical. Care shall be taken to ensure that all the joints are fully filled up with mortar, well flushed up where on pointing is proposed. The joints in faces, which are plastered or painted, shall be squarely raked out to a depth not less than 12mm, while the mortar is still green. The raked joints shall be well brushed to remove the loose particles and the surfaces shall be cleaned with a wire brush so as to remove any splashes of mortar sticking to the surfaces during the construction. All iron fixtures, pipes, bolts, conduits, sleeves, hold fasts etc. which are required to be build into the walls shall be embedded in

cement mortar or cement concrete as shown in the drawings / indicated in the specifications / directed during the execution by the Engineer as the work proceeds and no holes be left for fixing them at a later date unless authorized by the Engineer.

### **Curing**

Green work shall be protected from rain by covering the work suitably. Masonry work as it progresses shall be thoroughly kept wet by watering on all the faces for at least 7 (seven) days after completion of the parts of the work. Proper watering cans, flexible pipes, nozzles shall be used for the purpose. The top of the masonry work shall be kept flooded at the close of the day's work by constructing filets of mortar 40mm high all around the edges of the top course. In case of fat lime mortar curing shall start two days after construction of masonry and shall continue for seven days. No additional payment is admissible for curing and the rates quoted are deemed to be inclusive of the cost of curing.

### **Scaffolding**

Double scaffolding sufficiently strong so as to withstand all loads that are likely to come upon it and having two sets of vertical supports shall be provided. Where two sets of vertical supports are not possible the inner end of the horizontal supporting pole shall rest in a hole provided in a header course only. Only one header for each pole shall be left out. Such holes, however shall not be permitted in pillars under one meter in width or immediately near the skewbacks of arches. Such holes shall be filled up immediately after removal of the scaffoldings. Safety Code for Scaffolds and Ladders, IS 3696 (Parts I and II) shall be followed.

Cement mortar used for plastering shall be of the mix preparations and thickness as specified on the drawings or bill of quantities or particular specifications for the various different parts of the works. The materials used i.e. cement, sand and water shall be of the same quality and of the same specifications as indicated for plain and reinforced cement concrete works according to the specifications and approved by the Engineer. Sand for plaster shall meet the specifications as laid down in IS 1542 specification for sand for plaster. The surfaces that are to be applied with plaster shall be thoroughly cleaned to remove dust, dirt, loose particles, oil, soil, salts etc. that may be sticking to the surfaces. The surfaces shall be washed clean and watered properly for 4 hours before applying plaster. Plaster shall not, in any case, be thinner than specified. It shall have uniform specified thickness. When smooth finishing is required the cement plastering shall be floated over with neat cement within 15 minutes after application of the last coat of plastering. The plaster shall be protected from the sun and rain by such means as the Engineer-in-charge may approve. The plastered surfaces shall be cured for 7(seven) days. Construction joints in plastering shall be kept at places approved by the Engineer. When the thickness of the plaster specified is to be made up in more than one layer the second layer shall be applied only when the lower coat is still green. Wherever specified approved brands of additives like water proofing compounds shall be added in specified quantities as recommended by the manufacture of the compound, or as directed by the Engineer. Whenever scaffolds are necessary for plastering they shall be provided as specified

for scaffolds. Stage scaffolding shall be provided for ceiling plaster.

To ensure even thickness and true surface, patches of plaster about 15 cm x 15cm shall be first applied both horizontally as vertically two mtrs apart. Plastering shall be done from top to bottom and care shall be taken to avoid joints on continuous surface. Surfaces which are to be plastered shall be roughened while they are still green or raked so as to give proper bond between the surface and plaster. All corner junctions shall be truly vertical or horizontal as the case may be and carefully finished. Rounding or chamfering for corners shall be carried out with proper templates to the required size and shapes. The work shall be tested frequently with a straight edge and plumb bob. At the end of the day the plaster shall be left cut clean to line. The next day when plastering is started the edge of the oldwork shall be scrapped, cleaned and wetted with cement slurry. At the end of the day the plastering shall be closed on the body of the wall and not nearer than 15cm to any corner.

Curing shall be started as soon as the plaster has hardened sufficiently not to be damaged when watered. The plaster shall be kept wet for at least 7days. Any defective plaster shall be cut in rectangular shape and replaced.

### Painting

All items of metal work shall be thoroughly washed, dried, cleaned, degreased before application of any paint.

Normally, the initial coats shall be applied in the manufacturer's shops. After arrival of the equipment on site, , the same shall be inspected and damaged portions shall be cleaned and given the primer and under coat of similar paint.

After erection all metal works shall be painted as follows :

- (a) Surface painted with red oxide of iron primer or with oil based under coat, shall receive two under coats and one finishing coat of an approved oil based paint.
- (b) Bituminous painted surfaces shall receive two coats of approved bituminous paint.
- (c) Galvanized surfaces shall be primed with chromate primer followed by two under coats and one finishing coat of approved oil based paint.
- (d) All indoor fixtures parts, instruments and electrical equipment shall be chromium or copper nickel plated.

The following table gives the nature of surface and paints to be used. The contractor should study and followings properly.

Sl. No.	Surface	Treatment
1	All railings, mild steel ladders, pipes for water supply, flooring etc.	Galvanization and two coats of approved oil based paint approved shades
2	Submerged metallic parts and their projections above water level.	Bituminous paints

3	Metal parts above water level	Approved oil paint of approved shades.
4	All indoor fixtures parts, instruments, equipments panels etc.	Chromium or nickel plating

### 2.8.0 REINFORCED CEMENT CONCRETE WORKGeneral

Steel reinforcement bars shall be of T.M.T. steel of standard specifications and shall be free from corrosion, loose rust scales, oil, grease, paint, etc. the steel bar shall be round and capable of being bent (double over) without fracture. Bars shall be hooked and bend accurately and placed in position as per design and drawing and bound together tight with 20 SWG annealed steel wire at their point of intersection.

Framework and shuttering shall be made with ply or steel plate close and tight to prevent leakage of mortar, with necessary props. Bracing's and wedges, sufficiently strong and stable and should not yield on laying concrete and made in such a way that they can be slackened and removed gradually without disturbing the concrete. For slab and beam small camber should be given in centering, 1 cm per 2.5 m with a maximum of 4 cm. Centering should not be removed before 14 days in general (4 days for RCC columns, 10 days for roof slab, and 14 days for beams).

Proportion of cement concrete: Cement concrete shall be of M- 20 for slab, beams and lintels and columns unless otherwise specified.

Materials for concrete: The stone aggregate shall usually be 20mm to 6mm gauge unless otherwise specified. For heavily reinforced concrete members as in the case of ribs of main beams the maximum size of aggregate should usually be restricted to 5mm less than the minimum clear distance between the main bars or 5mm less than the minimum cover to the reinforcement whichever is smaller.

Mixing is done in the same manner as in PCC.

Before laying the concrete, the shuttering shall be clean, free from dust, dirt and other foreign matter. The concrete shall be deposited (not dropped) in its final position.

In case of columns and wall it is desirable to place concrete in full height if practical so as to avoid construction joints but the progress of concreting in the vertical direction shall be restricted to one metre. Care should be taken that the time between mixing and placing of concrete shall not exceed 20 minutes so that the initial setting process is not interfered with. During the winters concreting shall not be done if the temperature falls below 40 C.

Concrete shall be compacted by mechanical vibrating machine until a dense concrete is obtained. The vibration shall continue during the entire period of placing concrete. Compaction shall be completed before the initial setting starts, i.e. within 30 minutes of addition of water to the dry mixture. Over vibration, which will separate coarse aggregate from concrete, shall be avoided. After removal of the form work in due time, the concrete surface shall be free from honey combing, air holes or any other defect.

Concrete shall be laid continuously, if laying is suspended for rest or for the following day the

end shall be shuttered and vibrated to achieve dense concrete and made rough after de-shuttering for further jointing. When the work is resumed, the previous portion shall be roughened, cleaned and watered and a grout of neat cement shall be applied and the fresh concrete shall be laid. For successive layer the upper layer shall be laid before the lower has set.

### **Standards**

Following Indian Standards as revised most recently along with amendments will be followed for the works included in the contract.

I.S. 269 Ordinary and low heat Portland cement

I.S. 383 Coarse and fine aggregates from natural sources for concrete

I.S. 456 Code of practice for plain and reinforced concrete

I.S. 516 Methods of test for strength of concrete

I.S. 1199 Methods of sampling and analysis of concrete

I.S. 2386 Methods of test for aggregates for concrete (Part I to VI).

I.S. 3414 Code of practice design and installation of expansion and contraction joints in building Standards on special subjects have been mentioned elsewhere in this para and also shall be followed.

### **Forms, Falsework or Centering**

#### **Definitions**

“Forms, formwork or shuttering” shall include all temporary moulds for forming the concrete to the required shape, together with any special lining that may be required to produce the concrete finish specified.

“Falsework or centering” shall consist of furnishing, placing and removal of all temporary construction such as forming, props and struts required for the support of forms.

#### **Materials – only steel shuttering**

All timber used for forms, falsework and centering shall be sound wood, well-seasoned and free from loose knots, shakes, large cracks, and warping and other defects. Before use on the work, it shall be properly stacked and protected from injury from any source. Any timber, which becomes badly warped or cracked prior to the placing of concrete, shall be rejected.

All shuttering from all outside surfaces shall be made in such a way that a smooth surface and straight edges will be formed. Irrespective of nature or position, all joints in sheeting shall be sufficiently tight to prevent leakage of liquids from concrete.

For shuttering in special position shall submit to the Engineer dimensioned drawings of all the components parts and give details to the manner in which it is proposed to assemble or use them. Steel shuttering will only be permitted if it is sturdy in construction and if the manner of its use is approved by the Engineer. Struts and props shall, where required by the Engineer, be fitted with double hardwood wedges or other approved devices so that the moulds may be

adjusted and the device locked before the concrete is cast. Where concrete surface is to be plastered ply shuttering is to be provided.

### **Forms**

All forms shall be of marine plywood of approved brand such as Anchor / Swastik or mild steel or other material approved by the Engineer and shall be fabricated and prepared water tight and of sufficient rigidity to prevent distortion due to pressure of the concrete and other incidental loads that may arise due to the construction operations. Forms shall be constructed and maintained so as to prevent warping and the opening of joints due to shrinkage of the timber.

All forms shall be set and maintained true to the line designated until the concrete is sufficiently hardened. Forms shall remain in place for periods, which shall be specified hereinafter. When forms appear to be unsatisfactory in any way, either before or during the placing of concrete, the Engineer shall order to stop the work until the defects have been corrected.

All formwork shall be approved by the Engineer-in-charge before concrete is placed within it. The contractor shall be required to submit copies of his calculations of the strength and stability of the formwork or false work but not withstanding the Engineer's approval of these calculations nothing shall relieve the contractor of his responsibility for the safety or adequacy of the formwork.

Formwork shall be true to line and braced and strutted to prevent deformation under the weight and pressure of the unset concrete, constructional load, wind and other forces. The deflection shall not exceed 3mm. Beam bottom shall be erected with an upward camber of 2mm per meter of the span. The formwork for a column may be erected to the full height of the column.

One side shall be left open and shall be built up in sections as placing of the concrete proceeds. Before placing the concrete, bolts and fixings shall be in position and cores and other devices, used for forming openings, holes, chases, recesses and other cavities shall be filled to the formwork. No holes shall be cut in any concrete unless approved. An approved mould oil or other material shall be applied to faces of formwork in contact with unset concrete to prevent adherence of the non-staying concrete. Such coating shall be insoluble in water, non-staying and non-detrimental to the concrete and shall not be flaky or removed by wash water.

### Tolerance in finished concrete

The formwork shall be so made as to produce a finished concrete true to shape, lines, level, plumb and dimensions as shown in the drawing subject to the following tolerance, unless otherwise specified in drawings or directed by the Engineer.

- a. Sectional dimensions - 5mm
- b. Plumb - 1 in 1000 of height

- c. Levels - 3mm before any deflection has taken place

The tolerances given above are specified for local aberration in the finished concrete surface and should not be taken the tolerance for the entire structure taken as a whole.

### **Falsework & Centering**

The contractor shall supply detailed plans for falsework or centering if specifically asked for by the Engineer at least 14 days in advance of the time the contractor begins construction of the falsework. Notwithstanding the approval by the Engineer of any design for falsework submitted by the contractor, the contractor shall be solely responsible for the strength, safety and adequacy of the falsework or centering.

All falsework shall be designed and constructed to provide the necessary rigidity and to support the loads from the weight of green concrete and shuttering and incidental construction loads.

Falsework or centering shall be founded upon a solid footing safe against undermining and protected from softening.

Falsework, which cannot be founded on satisfactory footing, shall be supported on piling which shall be spaced, driven and removed in a manner approved by the Engineer. The Engineer may require the contractor to employ screw jacks or hardwood wedges to make up any settlement in the formwork either before or during the placing of concrete. Props of the upper storey shall be placed directly over those in the storey immediately below.

Falsework shall be set to give the finished structure the required grade and camber specified on the plans.

### **Formwork and Construction joints**

Where permanent or temporary joints are to be made in horizontal or inclined members, stout stopping off boards shall be securely fixed across the mould to form a water tight joint. The form of the permanent construction joint shall be as shown on the drawings. Temporary construction joints shall have blocks of timber at least 75mm thick, slightly tapered to facilitate withdrawal and securely fixed to the face of the stopping off board. The area of the key or keys so formed shall be at least 30% of the area of the member. The blocks shall be kept back at least 50mm, from the exposed face of the concrete.

Where reinforcement passes through the face of a construction joint the stopping off board shall be drilled so that the bars can pass through, or the board shall be made in sections with a half round indentation in the joints faces for each bar so that when placed, the board is a neat and accurate fit and no grout leaks from the concrete through the bar holes or joints.

### **Removal of Forms & Falsework**

In the determination of the time for the removal of forms, falsework and housing, consideration shall be given to the location and character of the structure, the weather and other conditions influencing the settings of the concrete and the materials used in the mix.

Forms shall be removed in such a manner as not to injure the concrete and no formwork shall be removed before the concrete has sufficiently set and hardened. The minimum periods which shall elapse between the placing and compacting of normal Portland cement concrete for the various parts of the structures are given in the following table, but compliance with these requirements shall not relieve the contractor of the obligation to delay the removal of the form if the concrete has not be sufficiently hard.

In normal circumstances, generally where the temperature are above 200 C and where ordinary cement is used, form may be struck after the expiry of following periods, according to the relevant clauses of IS 456.

a.	Walls columns and vertical sides of beams	2 days
b.	Slabs – soffit	
	1. Spanning upto 4.5m	7 days
	2. Spanning over 6.0m	14 days
c.	Beams and arches – soffit	
	1. Spanning upto 6.0m	14 days
	2. Spanning over 6.0m	28 days

Where sulphate resistant cement is used, manufacturer instruction are to be followed.

The Engineer may modify these requirements taking into account the type of cement and method of compaction used and contractor shall obtain the Engineers written approval for any decrease in time of striking the formwork given above. The contractor shall notify the Engineer when he proposes to strike any formwork and formwork shall be struck in the presence of the Engineer or his representative.

#### **Reuse of Forms**

Only mild steel formwork of best quality or marine plywood formwork shall be used for concerning purpose. These shuttering shall not be reused unless it is properly scraped cleaned and repaired. So that it gives a plane, even, fair and dense concrete surface.

#### **Materials Water**

Water used for cement concrete mortar plaster, grout, curing or washing of sand shall be clear and free from injurious amounts of Oil, Acid, Alkali, Organic matter or other harmful substances in such amounts that may impair the strength or durability of the structure. Potable water shall generally be considered satisfactory for mixing and curing concrete. In case of doubt regarding development of strength, the suitability of water for making concrete shall be ascertained by compressive strength and initial setting time specified in the IS 456: 2000 Code of Practice of Plain and Reinforced concrete. The Engineer-in-charge may require the contractor to get the water tested from an approved laboratory at his own expense and in case the water contains any salts or an excess of acid, alkali, any injurious substances etc., the Engineer-in-charge may refuse its use.

### **Aggregate General**

Coarse and fine aggregates for concrete shall conform in all respects to IS: 383 – Specification for Coarse and Fine Aggregates from Natural Sources for Concrete. Aggregates shall be obtained from a source known to produce satisfactory material for concrete. Aggregate shall consist of naturally occurring sand and gravel or stone, crushed or uncrushed or a combination thereof. They shall be chemically inert, hard strong, dense, durable, clean and free from veins and adherent coating and of limited porosity. Flaky and elongated pieces shall not be used. Whenever required by the Engineer-in-charge the aggregates shall be washed by the contractor before use in the work.

The source of aggregates shall be approved by the Engineer-in-charge and shall not be changed during the course of the job without his approval. The contractor at his own expense shall promptly remove rejected aggregates from the work site.

### **Deleterious Materials**

Aggregates shall not contain any harmful material, such as iron pyrites, coal, mica, shale, clay, alkali, soft fragments, sea shells, organic impurities etc., in such quantities as to affect the strength and durability of the concrete and in addition to the above, for reinforced concrete, any material which might cause corrosion of the reinforcement. Aggregate which are chemically reactive with the alkali of cement shall not be used.

The maximum quantities of deleterious materials in the aggregate as determined in accordance with IS : 2386 (Part-II) Methods of Test for Aggregates for Concrete, shall not exceed the limits given in Table I of IS : 383.

The sum of the percentages of all deleterious materials shall not exceed five. Deleterious materials also include materials passing 75 micron IS sieve.

### **Coarse Aggregates**

Coarse aggregates is aggregate most of which is retained on 4.75 mm IS : sieve.

These may be obtained from crushed or uncrushed gravel or stone and may be supplied as single sized or graded aggregates as given in table II of IS : 383.

The Engineer-in-charge may allow graded aggregates to be used provided they satisfy the requirements and table IV of IS : 383.

### **Fine Aggregates**

Fine aggregate is aggregate most of which passes 4.75 mm IS sieve but not more than 10% passes through 150 micron IS sieve. These shall comply with the requirements of grading zones I, II and III as given in Table III of IS : 383. Fine aggregate conforming to grading zone IV shall not be normally used in reinforced concrete unless tests have been made by the contractor to ascertain the suitability of the proposed mix proportions and approved by the Engineer-in-charge. Fine aggregates shall consist of natural sand resulting from natural disintegration of rock and which streams or glacial agencies, have deposited, or crushed stone

sand or crushed gravel sand.

### **Sampling and Testing**

In case of doubt the Engineer-in-charge may require the contractor to carry out tests, at the contractor's expense, in accordance with :

IS : 516 - Method of Test for Strength of Concrete

IS : 2386 - Methods of Test for Aggregate for Concrete

### **Storage of Aggregate**

The contractor shall at all times maintain at the site of work such quantities of aggregates as considered by the Engineer-in-charge to be sufficient to ensure continuity of work.

Each type and grade of aggregate shall be stored separately on hard firm ground having sufficient slope to provide adequate drainage of rain water. Any aggregate delivered to site in a wet condition or becoming wet at site due to rain shall be kept in storage for at least 24 hours to obtain adequate drainage, before it is used for concreting, or the water content of mix must be suitably adjusted as directed by Engineer-in-charge.

### **Cement General**

Cement used in manufacturing of PSC pipes shall be as per relevant BIS Gr. 43/53 cement conform to relevant BIS shall be used. However, the cement shall be procured by the contractor from the vendor, which has been approved by the Engineer.

### **Structural Steel**

Structural (TMT) steel shall conform to IS : 226 & IS : 2062, IS :3370, Part- I to IV or its latest amendment.

Electrodes for welding shall conform to IS : 814 or IS : 815 or equivalent.

All bolts and nuts shall conform to IS : 1367. All materials shall be of new and unused stocks. Manufacturer's test certificate shall be made available to the Engineer-in-charge when called for Storage.

The steel reinforcement and structural steel shall be stored in steel yard in such a way as to prevent deterioration and corrosion, preferably at least 150 mm above ground by supporting on wooden or concrete sleepers.

### **Proportioning of Concrete**

The determination of the water cement ratio, and proportions of aggregates to obtain the required strength shall be made from preliminary tests by designing the concrete mix.

Controlled concrete shall be used on all concrete work complying with all the requirements of IS : 456, or latest amendments. Cube tests shall be carried out by the contractor on the trial mixes before the actual concreting operation starts. Based on the strength of the concrete mix sanction for its use has to be obtained from Engineer-in-charge.

If during the execution of the works it is found necessary to revise the mix because of the cube tests showing lower strengths than the required one due to inconsistency of quality of material or otherwise, the Engineer-in-charge shall ask for fresh trial mixes to be made by the contractor. No claim to alter the rates of concrete work shall be entertained due to such change in mix variation, as it is the contractor's responsibility to produce the concrete of the required grade.

Great care shall be exercised when mixing the actual works concrete using the proportions of the selected trial mix. The final concrete mix shall have the same proportions of cement, fine and coarse aggregates and water as that of the approved selected mix.

Where the weight of cement is determined by accepting the manufacturer's weight per bag, a reasonable number of bags should be weighed separately to check the net weight. Proper control of mixing water is deemed to be of paramount importance. If mixes with automatic addition of water are used, water should be either measured by volume in calibrated buckets, tins or weighed. All measuring equipment shall be maintained in a clean serviceable condition and their accuracy periodically checked and certified and the Engineer-in-charge's approval obtained.

The Engineer-in-charge may require the contractor to carry out moisture content tests in both fine and coarse aggregates. The amount of the added water shall then be adjusted to compensate for any observed variation in the moisture contents. For the determination of moisture content IS : 2386 shall be referred to.

No substitution in material, used on the work or alteration in the established proportions shall be made without additional tests to show that the quality and strength of concrete are satisfactory. No alternations shall be permitted without the prior sanction of the Engineer-in-charge.

#### **Mixing of concrete**

The mixing of concrete shall be strictly carried out in an approved hopper type of mechanical concrete mixer. The mixing equipment shall be capable of combining the aggregates, cement and water within the specified time into a thoroughly mixed and uniform mass, and of discharging the mixture without segregation. The entire batch shall be discharged before recharging. Mixing periods shall be measured from the time when all of the solid materials are in the mixing drum, provided that all of the mixing water shall be introduced before one fourth of the mixing time has elapsed.

The mixing time in no case shall be less than two minutes. The mixer speed shall not be less than 14 or more than 20 revolutions per minute.

Mixing shall be continued until there is a uniform distribution of the materials and the mass is uniform in colour and consistency. Hand mixing of concrete shall not be permitted at all.

#### **Grades of Concrete**

The different grades of concrete specified shall conform to the strengths as required by IS :

456 or its latest amendments.

Standard deviation shall be calculated as stated in IS : 456. The acceptable criteria for concrete shall be as stated in IS : 456.

The assumed standard deviation as given in table 6 of IS: 456. has to be followed and are given hereunder.

Grade of Concrete (N/mm <sup>2</sup> )	Assumed Standard Deviation
M 10	2.3
M 15	3.5
M 20	4.6
M 25	5.3

In order to get quick ideas of quality of concrete the optional tests are conducted as stipulated in 14.1.1 of IS : 456.

#### **Controlled Concrete**

Controlled concrete shall be used on all concreting works except where specified otherwise.

The mix proportions for all grades of concrete shall be designed to obtain strengths corresponding to the values specified below

Grade Specified	Characteristic compressive Strength at 28 days (N/mm <sup>2</sup> )
M 20	20
M 25	25
M 30	30

The maximum water cement ratio for all controlled concrete works shall be as specified in IS : 456. Preliminary tests as specified in the IS code and required by the Engineer-in-charge shall be carried out sufficiently ahead of the actual commencement of the work with different grades of concrete made from representative samples of aggregates and cement expected to be used on the job to ascertain the ratios by weight of cement, of total quantity of fine and coarse aggregates and the water cement ratio required to produce a concrete of specified strength and desired workability.

The minimum cement content for each grade of concrete shall be as per IS : 456 (Latest Revision). If the requirement of cement is found to be more than that specified below then such excess quantities of cement shall be used and for which no extra payment shall be made.

At least 4 (four) trial batches are to be made and 7 test cubes taken for each batch noting the slump on each mix. These cubes shall then be properly cured and two cubes for each mix shall be tested in a testing laboratory approved by the Engineer-in-charge at 7 days and others at 28 days for obtaining the ultimate compressive strength. The test reports shall be submitted to the Engineer-in-charge. The cost of mix design and testing shall be borne by the contractor.

On the basis of preliminary test reports for trial mix, a proportion of mix by weight and water cement ratio will be approved by the Engineer-in-charge, which will be expected to give the required strength, consistency and workability and the proportions so decided for different grades of concrete shall be adhered to, during all concreting operations. If however at any time the Engineer-in-charge feels that the quality of material, being used has been changed from used for preliminary mix design, the contractor shall have to run similar trial mixes to ascertain the mix proportions and consistency.

The mix once approved must not be varied without prior approval of the Engineer-in-charge. However, should the contractor anticipate any change in the quality of future supply of materials than that used for preliminary mix design, he shall inform the same to the Engineer-in-charge and bring fresh samples sufficiently ahead to carry out fresh trial mixes. The Engineer-in-charge shall have access to all places and laboratory where design mix is prepared. Design mix will indicate by means of graphs and curves etc. the extent of variation in the grading of aggregates which can be allowed. In designing the mix proportions of concrete, the quantity of both cement and aggregate shall be determined by weight. All measuring equipment shall be maintained in clean and serviceable condition and their accuracy periodically checked. To keep the water cement ratio to the designed value, allowance shall be made for the moisture contents in both fine and coarse aggregates and determination of the same shall be made as frequently as directed by the Engineer-in-charge. The determination of moisture contents shall be according to IS : 2386 (Part III).

#### Strength Requirements

Where ordinary Portland cement conforming to IS : 269 is used the compressive strength requirements for various grades of concrete shall be as shown in Table – 3. Where rapid hardening Portland cement is used the 28 days compressive strength requirements specified in table – 3 shall be met in 7 days. The strength requirement specified in Table shall apply to both controlled concrete and ordinary concrete.

Grade of concrete As per IS : 456-2000	Min. compressive strength conducted in Accordance with IS : 516 (in kg/cm <sup>2</sup> )		
	For 15 cm cube specimen at 7 days		For 15 cm cube specimen at 28 days
	Work Test	Preliminary	Work Test
M 20	135	260	200
M 25	170	320	250
M 30	200	380	300

Other requirements of concrete strength as may be desired by the Engineer-in-charge shall be in accordance with Indian Standard IS : 456 (latest revision). The acceptance of strength of concrete shall be as per clause 5.4 : Sample size and Acceptance criteria: of IS

: 456 (latest revision) subject to stipulations and / or modifications state elsewhere in this specification, if any. Concrete work found unsuitable for acceptance shall have to be dismantled and replaced to the satisfaction of the Engineer-in-charge by the contractor free of cost to the owner. No payment for the dismantled concrete, the relevant formwork and reinforcement, embedded fixtures, etc. wasted in the dismantled portion shall be made. In the course of dismantling if any damage is done to the embedded items or adjacent structures, these shall also be made good free of charge by the contractor to the satisfaction of the Engineer-in-charge. If the water quantity has to be increased in special cases, cement also is increased proportionately to keep the ratio of water to cement same as adopted in trial mix design for each grade of concrete. No extra payment for the additional cement will be made.

### Workability

The workability of concrete shall be checked at frequent intervals by slump test. Where facilities exist and if required by the Engineer-in-charge, alternatively the Compacting Factor. Test in accordance with IS : 1199 shall be carried out. The degree of workability necessary to allow the concrete to be well consolidated and to be worked into the corners of formwork and round the reinforcement to give the required surface finish shall depend on the type and nature of the structure and shall be based on experience and tests. The limits of consistency for structures are as specified in Table below.

Placing Conditions	Degree of Workability	Values of Workability
1	2	3
Concreting of shallow section with vibrations	Very low	20-10 second veebee Time or 0.75-0.80 compacting factor
Concreting of lightly reinforced sections with vibration	Low	10-5 seconds veebee Time or 0.80-0.85 Compacting factor
Concreting of reinforced lightly sections without vibration or heavily reinforced section with vibration	Medium	5-2 seconds veebee Time or 0.85-0.92 Compacting factor Or 25-75 mm slump for 20mm aggregate
Concreting of heavily reinforced sections without vibration	High	Above 0.92 Compacting factor or 75-125mm slump for 20mm aggregate

### Minimum Period for Removal of Formwork

Part of structure	Temperature in degrees Celsius			Remark
	Above 40 <sup>0</sup>	40 <sup>0</sup> to 20 <sup>0</sup>	20 <sup>0</sup> to 5 <sup>0</sup>	
	Days	Days	Days	
<b>A. Ordinary Portland Cement Concrete</b>				
1. Column and walls	2	1	1	Do not remove form. Until site cured test cylinder / cubes develop 50% of 28 days
2. Beams sides	3	2	3	
3. Slabs 125mm thick or less	10	7	8	Do not remove form Until site cured test Cylinder / cubes develop 50% of days strength
4. Slabs over 125mm thick and soffit of minor beams	18	14	16	
5. Soffit of main beams	24	21	22	
<b>B. Rapid Hardening Portland Cement concrete</b>				
1. Column and walls	1	1.5	1	Do not remove forms until site cured test Cylinder / cubes develop 50% of days strength
2. Beams sides	2	1	1	
3. Slabs 125mm thick or less	7	4	5	
4. Slabs over 125mm thick and soffit of minor beams	12	8	9	
5. Soffit of main beams	10	12		

Note: for Portland Puzzolona Cement the removal time should be suitably increased over the time given for ordinary Portland Cement, as directed by the Engineer-in-charge.

#### Reuse of forms

Before reuse all forms shall be thoroughly scrapped, cleaned, joints, etc. examined and when necessary, repaired and inside surface treated as specified herein before. Formwork shall not be used / reused, it declared unfit or unserviceable by the Engineer-in-charge.

#### Classification of formwork

##### Ordinary

These shall be used in places where ordinary surface finish is required and shall be composed of steeland / or approved good quality seasoned wood.

##### Plywood

These shall be used in exposed surfaces, where specially good finish is required and shall be made mostly of approved brand of heavy quality shuttering / marine plywood to produce a perfectly level, uniform and smooth surface.

Ordinary formwork shall be used for all underground structures and „plywood“ formwork shall be used for all structure above ground.

Acceptance of formwork and finished concrete shall be true to shape, lines, levels, plumb and dimensions as shown on drawings. All embedded fixtures shall be correct type and in correct position as shown in drawing. Finished concrete surface shall be free from blemishes like honeycombs, air bubbles, fins etc. Exposed decorative concrete surfaces shall be free from rust, stains grease and mould oil stains, etc. and shall have uniform pleasing appearance to satisfaction of the Engineer-in-charge. If desired, the finished concrete shall conform in all respects to the accepted sample.

Where exposed surface of concrete can be effectively sealed to prevent loss of water the periods specified for temperature above 400 C can be reduced to those for the temperature range of 200 to 400 C subject to approval of the Engineer-in-charge. Before removing any formwork, the contractor must notify the Engineer-in-charge well in advance to enable him to inspect the concrete, if he so desires.

#### **Tolerance in finished concrete**

The formwork shall be so made as to produce a finished concrete true to shape, lines, level, plumb and dimensions as shown in the drawing subject to the following tolerances unless otherwise specified in this specification or drawings or directed by the Engineer-in-charge.  
For

- |    |                      |   |  |
|----|----------------------|---|--|
| a. | Sectional dimensions | = | + 5mm                                      |
| b. | Plumb                | = | 1 in 1000 of height                        |
| c. | Levels               | = | +3mm before any deflection has taken place |

This tolerance given above are specified for local aberration in the finished concrete surface and should not be taken as tolerance for the entire structure taken as a whole for the setting and alignment of formwork which should be as accurate as possible and true to shape required to the entire satisfaction of the Engineer-in-charge. Any error, within the above tolerance limits, or if noticed in any lift of the structure after stripping of forms, shall be corrected in the subsequent work to bring back the surface of the structure to its true alignment.

#### **Curing**

Curing etc. of the structures shall be exactly same as for reinforced concrete structures.

Vertical joints

All vertical joints shall extend full height of the wall in unbroken alignment.

#### **Removal of Shuttering**

Removal of the formwork shall conform of IS 456-2000. Bolts and fasteners passing completely through liquid retaining slabs for the purpose of securing and aligning the

formwork should not be used unless effective precautions are taken to ensure the water tightness after the removal of pipes or other fittings. Puddle flange in concreting shall be placed at correct positions, before concreting and verified by the Engineer-in-charge.

#### **Water Tightness**

The test for water tightness of the structure shall be carried out as per clause 10 of IS : 3370 part 3.

#### **Workmanship**

No finish shall be executed until a sample of the finish to the required colour and the Engineers approves shade. Where more than one coat is required the Engineer shall approve each coat before subsequent coat is applied.

The colour shall be of even shade over the whole surface, shall not be of patchy appearance or badly applied. Surfaces of doors, windows, floors, articles of furniture etc. shall be protected from being splashed upon. They shall also be cleared after the work is completed. No damage shall be caused to them and in case any damage is caused they shall be made good by the contractor at his own cost. Necessary scaffolding or suspended platforms, or ladders, stage scaffoldings shall be provided. For such ladders / scaffolding, protective gunny bag sacking shall be tied to prevent scratches to the flooring or walls to which they come into contact. The surfaces to which white or colour wash is to be applied shall be cleaned thoroughly to remove all dust, dirt, mortar drops, grease and other foreign matter before the white or colour wash is applied. All depressions holes etc. shall be filled in with mortar or putty, plaster of pans and the surface is smoothened before application of the white / colour washes / distempers to the surfaces. Colour wash shall be prepared by adding mineral colour not affected by lime, gradually to the base wash prepared as for white wash and stirred well till a required tint is obtained. Sufficient quantity of colour wash shall be prepared so as to be adequate for completing the work in one operation to avoid any difference in shades.

For colour wash the first base coat shall be of white wash and subsequent coats of colour wash solution in full number of coats and the Engineer shall approve the shades so obtained shall be approved by the Engineer. Wherever distemping is specified whether dry or oil bound distemper the surfaces shall be prepared so as remove all the dirt, grease, mortar dropping and all rubbish and shall be made smooth if required by filling up all depressions by putty, plaster of Paris, cement mortar etc. and sand papered and dust wiped off. Subsequent coats shall be applied as recommended by the manufacturer after mixing the distemper as specified by them. The various coats shall be applied only after the previous coats are thoroughly dried. Distemper shall be applied only in dry weather with double bristled distemper brushes. The first coat shall always be of lighter colour than that required finally and the subsequent coat shall be applied only after the previous one is thoroughly dried for atleast 24 hours or as suggested by the manufacturer.

For cement paint the surfaces shall be prepared as indicated for white and colour wash. Before applying the surfaces shall be wetted thoroughly to control surface suction. The surfaces shall be moist and not dripping wet. Surfaces which readily absorb moisture shall be wetted in one operation not more than one hour before the application of the cement paint.

Surface which absorbs moisture slowly shall be wetted in at least two operations not less than 30 minutes apart. The cement paint solution shall be prepared as recommended by the manufacturer and kept stirred frequently in the container to prevent segregation. The lids of the cement paint drums shall be tightly closed when not in use as the cement paint rapidly becomes air set. Curing shall be carried out with water using a fog spray two or three times a day. Curing shall also be done between coats and for at least for two days after final coat is applied. Cement paint shall be applied with relatively short stiff hog or fiber bristles.

The paint shall be brushed in uniform thickness and shall be free from excessive brush marks. The laps shall be well brushed. On external plastered and concrete surfaces cement paints shall be vigorously scrubbed on in such a way as to work the paint into the voids and provide a continuous paint film free from pin holes and other opening. The finished surface shall present an even and uniform shades without patches, paint drops etc.

#### **Painting:**

All exposed R.C.C. works will be painted with 3 coats of Apex (of Asian Paints) or equivalent as per colour scheme decided by the Engineer. The pipes fittings, steel ladders, angle iron etc. shall be painted with 3 coats of approved anticorrosive paint over and above a primer. All railings and expanded metal jali etc. shall also be painted with 3 coats of approved quality and shade paint over a primer.

All painting of work will have to be carried out after the tank is tested for water tightness to the satisfaction of the Engineer. Colour scheme shall be given by the Engineer.

#### **Doors, Windows, Grills, Rolling Shutters Etc.**

The items under this clause cover doors, windows, grills, rolling shutters, collapsible gates etc. normally required to be provided in a building used whether for residential, office, laboratory or industrial purpose. Doors and windows shutter and window mesh to check the brides shall be of aluminium as specified in the bill of quantities / drawings or as directed by the engineer. The sizes of the above items and locations of the same shall be as shown in the drawings.

All the doors (except rolling shutters) windows (glazed +mesh) & ventilators to be provided of Aluminium and rolling shutters made of 18 gauge M.S. sheet of approved make.

They shall be provided with all necessary fittings will be ISI marked like hold fasts, hinges, locking arrangements stoppers, eyes and hooks, tower bolts, handles, fixing lugs etc. of sizes and quality grade as specified.

They shall be provided in complete form including painting, glazing, fixing in position true to level and plumb, steel rolling shutters shall be of approved make and shall conform to **IS : 6248-1979**. Metal rolling shutters and rolling grills.

The builder's hardware shall all be as per relevant Indian Standards.

### **2.9.0 Structural Steel Fabrication Work**

#### **General**

Structural steel fabrication work shall include all types of steel structural work required for installation of platforms for operation and installation of equipment where rolled steel sections are joined together either by bolting or riveting or welding as specified in the drawings / bill of quantities / directed by the engineer. It shall also include fabrication and installation of air vessels / pressure vessels etc. Covers for ducts for electrical panels along with their seating arrangements are also classified under this heading unless they are provided separately under a different heading.

### **Materials**

Structural steel that is used for fabrication shall be conforming to any of the following grades of steels as specified to each of the works.

**IS 226-1975**                      Structural steel (standard quality)

**IS 1977-1975**                      Structural steel (ordinary quality)

**IS 2062-1980**                      Weld able Structural steel (fusion quality)

Whenever steel is supplied by the contractor, he shall on demand produce the test certificates from the manufacturer.

The welding rods used for fabrication shall conform to **IS 814-1974** (part I & II). The fasteners like bolts, nuts etc. shall conform to **IS 1367**.

Rivets shall conform to **IS 1148-1982**. Plain washers shall conform to **IS 2016-1967**.

Spring washers shall conform to **IS 3063-1972**.

### **Fabrication**

All the shop drawings shall be prepared by the contractor and submitted in advance of at least 15 days to the engineer for his approval. The drawings shall be submitted in triplicate. The fabrication work shall not be taken in hand until the shop drawings are approved by the engineer. Approval of the shop drawings however shall not relieve the contractor of his responsibility of correct conformation to the approved drawings shall be given to the contractor for going ahead with the fabrication work.

In the shop drawings to be submitted by the contractor standards symbols as described in the **IS 813- 1961** shall be followed.

Fabrication work shall be carried out as laid down in **IS 800-1984** Code of practice for general construction in steel.

Welding shall be carried out in accordance with the following specifications as applicable :

**IS : 803-1976** Code of practice for design fabrication and erection of vertical mild steel cylindrical welding oil storage tanks

**IS : 816-1969** Code of practice for use of metal arc welding for general construction in mild steel

**IS : 822-1970** Code of practice for manual arc welding of mild steel

**IS : 9595-1980** Recommendation metal are welding of carbon radiographic tests are required to be carried out as directed by the engineer in case of pressure vessel

**IS : 818-1968** Code of practice for safety and health requirements in electric and gas welding and cutting operations.

**IS : 3016-1982** Code of practice for fire precautions in welding and cutting operations

**IS : 7205-1973** Safety code for erection of structural steel work

The sanctions shall be fixed absolutely vertical or to the specified angle as shown in the drawings / as desired / directed by the engineer.

All connections like angle bracket, cleats, gusset plates, anchor bolts, bearing plates shall all be fixed as shown in the drawings. This shall also include all labour costs, materials and equipment required for all fabrication hoisting, erection and satisfactory completion of the item of work.

The supply of materials include all structural members like rolled sections, plates, brackets rivets, bolts and nuts and welds.

The steel work shall be painted as specified in the drawings, described in the bill of quantities or as directed by the engineer, unless otherwise provided for in the bill of quantities separately, the rate quoted for the item is inclusive of all costs for painting like cost of paint, cost of labour, scaffolding etc. Welding work shall be done generally using electric arcs welding. Where public electricity is not available, generators shall be arranged by the contractor himself.

Gas welding shall not be allowed to be resorted to for welding. Under special circumstances if in the opinion of the engineer it cannot be avoided, gas welding can be done with the prior permission of the engineer. However gas welding shall not be used criteria for consideration.

All arrangements shall be made by the contractor for access for inspection by the engineer or his representative to the workshop where the welding work is being carried out and necessary equipment like gauges, measuring instruments etc., shall be made available to the inspecting personnel.

Painting work shall not be started without the express approval of the engineer and the painting shall be started only after his inspection and approval of the works after carrying out surface preparations.

All holes shall be carefully marked and welded. Holes shall have their axis perpendicular to the surfaces bored through. Hole through two or more members shall be truly concentric. Holes shall not be formed by welding process.

All the temporary connections of parts / assembly shall be done in the following ways : For welded structures : Tack welding fasteners, devices, fixtures.

For riveted and bolted structures joining shall be done by adequate number of bolts. If tack welding is permitted by the Engineer, same shall be removed after the work is completed.

For the riveted structure in which holes are to be drilled after assembly appropriate fixtures shall do joining.

Welded joints shall be free from defects that would impair the service performance of the construction. All the welds shall be free from incomplete penetration, incomplete fusion, slag inclusion, burns, un-welded craters undercuts and cracks in the welded metal, porosity etc. All the defects shall be rectified as directed by the Engineer. Defective portions shall be removed to the sound metal and re-welded. Caulking shall not permit rectification of the welds by caulking.

All welds shall be cleaned of slag and other deposits after completion.

#### **Water Proofing And Damp Proofing**

The specifications described under this section cover the general guidelines for water proofing of roofs by application of sodium silicate conforming to **IS 281**.

#### **Material**

Material to be used shall be commercial sodium silicate (water glass) in water on the proportions described.

#### **Preparation of Surface For Treatment**

The concrete for roof shall be laid to the slopes specified on drawings. Thus care shall be taken for the surface preparation, right from the stage of concreting.

After curing is over, the surface shall be thoroughly cleaned of all the dust, grit, greasy and oily matter and other deleterious material.

#### **Application**

Water glass solution shall be applied over the prepared surface in 3 coats as described below :

On the prepared surface sodium silicate solution (water glass) in a proportion of 1:4 (1 part of sodium silicate: 4 part of water) shall be applied, in such a way that one litre of solution covers 4 sqm. of surface. The surface shall be allowed to dry for 24 hours.

Over the third coat a layer of concrete 25mm thick with 12mm size stone chips shall be laid in proportion of 1:2:4 and finished smooth with neat cement slurry.

Care must be taken to cover the corners, joints of parapet and roof slab.

#### **Damp Proofing**

Damp proofing course where specified shall be provided as described below :

1. Two coats of hot tar shall be applied over the well cleaned surface of walls where DPC is to be provided.
2. Over the coat of bitumen cement concrete in proportion of 1:1 ½:3 shall be laid to the thickness specified on drawings.
3. After the concrete is fully cured, a layer of mixture of hot bitumen and coarse sand in a

proportion of 7:3 shall be laid. Thickness of the layer shall be 6mm.

#### **Expansion Joints & Construction Joints General**

The item of providing expansion joints in concrete includes all the material, labour, tools and plants necessary to completing the item in best workmanlike manner.

#### **Material**

The material to be used in the joints shall be ribbed PVC water stop or approved copper / metal sheet flashing of specified width approved by the engineer, bitumen impregnated fiber board as filler conforming to **IS 10566** and approved sealant material (in case of movement joint only).

#### **Joints In Floor**

Joints in floor shall be provided as specified on drawings.

In case of PVC water stops to be provided horizontal position flat footed PVC water stops shall be used.

The water stops shall be provided in such a way the half the portion of water stop (width wise) is embedded in the concrete and half remains exposed for next concrete.

Steel reinforcement shall not be discontinued where construction joints in floor are provided.

#### **Joints In Walls Movement Joints**

Movement joints shall be provided in the walls at position shown on drawings. Water stops shall be kept in position with the help of bitumen impregnated fiber board filler.

Concrete shall be laid in such a way that half the portion of water stop remains exposed for next concreting.

#### **Construction Joints**

Construction joints shall be provided between two lifts of concrete as shown on drawings.

A groove shall be formed around exposed portion the COPPER water stop for proper jointing. Care shall be taken during concreting to keep the water stop in vertical position.

In no case shall be water stop be punctured or nailed with the binding wire to keep it in position. Whenever required to be jointed the water stop shall be welded in T, x or L pattern or lapped as per the instruction of engineer.

### **3.0 DESIGN PARAMETERS OF OVER HEAD TANK:**

**3.1** Design is to be done in accordance with I.S. Code 456-2000 and 3370 Part I to IV or their latest revisions. Detail of calculation should be given.

The tank should be of INTZE type (on columns) with capacity and staging as described in Schedule -G here to attached. The design should preferably be based on Limit State theory. This area lies in zone IV of seismic zones of India, therefore, proper allowances for seismic

effects should be taken into account while getting it designed similarly wind pressure effect should also be taken into account. All R.C.C. works shall be done in 1:11/2:3 concrete mix. Higher mix may be used as per design requirement.

Minimum dimension of member shall be as follows:

a	Circular column	500 mm
b	Container wall	250mm
c	Bottom dome	250mm
d	Top dome	150mm
e	Braces	300mm

### 3.2 FOUNDATION:

3.2.1 The foundation of the over head tank may be deigned on raft or on piles depending on the soil investigation report. The works shall strictly be done in accordance with the drawing supplied by contractor and duly approved by the Engineer.

3.2.2 Though the tentative bearing capacity of the soil on which the over head tank is proposed to be constructed has been mentioned in Schedule -G but the contractor will be responsible to test the actual bearing capacity of the soil through its expert or any reputed Engineering Institute preferable by I.I.T& will submit to the department for its final decision for the safety of the structure. It may happen that some part of the foundation may be in subsoil, so the bidders are advised to make their own decision and give their rates accordingly. No extra claim on this ground shall be entertained if the foundation has to be laid subsoil.

### 3.3 STAGING

3.3.1 The staging should consist of columns and shall be measured from the top of the flooring upto the top of bottom ring beam i.e. after making allowance for raising of floor from ground level. The staging of OHT shall be minimum 22 m. The floors are usually kept 30 to 40 cm. above the ground level unless otherwise mentioned in Schedule -G. The contractor shall include in his rates the cost of required sand filling that may be required for this purpose as well as the cost of flooring which will consist of the following:

- (a) Filling and compaction of sand as required from 30 to 40 cm. above ground level.
- (b) 10 cm. thick PCC 1:4:8 with cement coarse sand and graded stone ballast of 40 MM gauge.
- (c) 10 cm. thick PCC 1:2:4 with cement, coarse sand and 12mm to 20mm graded stone ballast with nominal reinforcement.

### 3.4 STAIR CASE:

3.4.1 A separate stair case on two separate columns upto top of top ring beam shall be provided. Rise of steps should not exceed 20 cm and tread should preferably be 25cm with adjustments according to height and diameter of the tank. Landing to be provided at vertical intervals in between 2 to 3 metres (length of landing measured in the direction of ascend and descend) to be 1.25 meter has to be constructed. One meter wide gate with a cage of 2 M. height after 1st landing shall be provided in staircase as per direction of Engineer-in-charge.

### 3.5 RAILING:

(i) **On stair case:**

Railing in three rows of 20 mm dia G.I.( medium pipe) fastened on angle iron posts of size 50x50x6mm of clear height 1.25 metre and at a distance of 1.0 to 1.5 metre along the stair case from ground level to the top of the bottom ring beam shall be provided on both sides. In case of the stair case on two separate columns, the railing shall go up to the top of the top ring beam including the bridge portion between the top end of the stair case and the bottom of the top ring beam.

(ii) **Balcony:**

Railing shall also be provided all around the outer perimeter of the balcony in four rows of 20mm dia G.I. (medium) pipe fastened on angle iron posts of clear height of 1.50m.

(iii) **Over top ring beam:**

The railing around top ring beam shall be 1.0 m. high consisting of 4 rows of G.I. medium pipe 20mm dia. The height of railing over stair case shall be one meter from top of landing or step or top surface of middle ring beam to the top of top row of G.I. pipe 22Mm dia. The railing shall consist of 50x50x6mm angle iron posts properly embedded in R.C.C. and placed between 1 to 1.5 meter horizontally. The top of the angle irons must be smoothly finished so that chances of any accident may be avoided. In case of a column staging stair case shall be provided out side the column, mild steel gate with proper barricading upto a height 3 meters from G.L. shall be provided as directed by the Engineer.

**3.6 BALCONY:**

**3.6.1** 100 cm wide R.C.C. balcony shall be projected outside the vertical wall of the tank at the level from where the vertical wall starts around the vertical wall of the tank.

**3.7 WATER LEVEL INDICATOR:**

**3.7.1** This will consist of a 3mm flexible steel wire rope passing over four smooth 3 cm. dia S.S. pulleys with guide to prevent slipping of the rope. One end at this rope will be tied with a 45 cm. diameter copper ball float of 3mm thick copper sheet. The other end will be attached with a suitable lead moving up and down along a vertical. Indicator board of 2 mm thick amended S.S. plate fixed in a frame of S.S. angle of size 40x40x5mm. The board will be fixed on the one of the columns between 2<sup>nd</sup> and 3<sup>rd</sup> bracing by means of 40x6mm flat iron clamps. The water level indicator should have marks painted / embossed with black and red colours of meter and centimeters visible from a distance of 100m.

**3.7.2** Two numbers of 25mm dia S.S. pipes will be embedded one each in the roof slab and conical wall to pass flexible wire rope smoothly, this will be contractor's responsibility to ensure smooth and perfect working of the indicator. The white enameled plate of indicator board will be calibrated in meters/centimeters.

**3.8 LIGHTENING CONDUCTOR, LADDER, VENTILATOR, MANHOLES:**

**3.8.1** Lightening conductor shall be provided as required under rules laid down by electrical inspector to the Government of Uttar Pradesh and as per ISI specification No.2303/1963.

The lightning conductor shall consist of the following:

**3.8.2 Air Termination:**

Air termination shall consist of single pointed vertical aluminum rod 1m high and 25mm diameter having trishul at top. It must be fixed at top of ventilator cover on aluminum base plate with suitable bolts nuts and washers.

**3.8.3 Down Conductor:**

It shall consist of 20mmx3.5mm or 25mmx3.00mm continuous aluminum strip with its upper end attached to the base of the rod and it shall be carried down the side of the tank along one column on suitable wood battens not touching with tank body to ground level about 3 meters from the tank to a trench 60cm. deep and then taken down to the copper earth plate which is to be buried 60cm. below summer subsoil water level. The aluminum strip forming the down conductor shall be fastened to the walls of the tank in the following manner:-

Holes should be made in the columns and teak wood plugs inserted with cement mortar 1:1. The larger end of the wooden plug should go into the hold first. The aluminum strip should be fastened to these plugs either by suitable stopples or clamps with screws, or as directed by Engineer in charge.

The conductor should be in a straight line and sharp bends should be avoided.

Aluminum conductor should be connected to copper conductor by means of a thick layer of the lead between the two.

**3.8.4 Earth plate :**

It shall be a copper plate size 0.9x0.9mmx5mm and buried vertically at a distance of approximately 3 meters from the tank at depth as per requirement under Indian electricity rules/ISS/Rules laid by Electrical inspector to Government of U.P. The resistance of the soil at the earth plate should be less than 100 ohms. If it exceeds, the number of electrode should be increased. The contractor shall have to test the soil resistance -at his own cost in presence of Engineer's representative. A perforated 50mm

G.I. Pipe should be fixed for watering the earth plate and shall terminate at about 150mm. below ground level in a cast iron camber with its cover in level with the ground.

**3. 8.5 Testing Wire:**

Copper wire S.S. W.G. shall be provided with its upper end soldered and fixed with bolts and nuts to the base of the final rod. The lower end shall be connected to the aluminum strip at height of 1.5 M. above the G.L. by 150mm copper; link fixed to one end of the down conductor with bolts and nuts with a stud and fly nut. The testing wire shall be laid parallel to the down conductor on a separate teak wood batton at a distance of 80mm to 150mm.

**3. 8.6 Ladder:**

This will be 0.6 metre wide consisting of Stainless steel Section 65mm x 65mm x 6mm sides of stringers and rungs of 20 same section spaced 25 cm. centre to centre welded to the sides,

fixing of the ladders including supply of all materials, required for completion of the work.

**3. 8.7 Ventilator:**

Ventilator of suitable size (1.0 to 1.2 m dia) shall be provided at the crown of top dome, 150 mm dia R.C.C. posts of 50 cm. height should be constructed on top dome. No. of posts should be 8 or as instructed by Engineer-in-charge necessary to keep its plan circular. Over the above said posts SS grill with spacing of 10 cm with mosquito proof round wire mesh of opening size 3mm over 25mm square expanded stainless steel jali should be attached properly and soundly.

**3. 8.8 Manhole Cover :**

Manhole cover should be provided at the end of stair or ladder on the roof of the tank of size 60x60 cm. clear. A frame made of 50mmx50mmx6mm S.S. angle iron should be embedded into concrete of roof with 60x60mmx5mm S.S. plate cover hinges suitably at lower end with locking arrangement at upper end should be provided.

**3.9 Inlet, Outlet, Over flow, Washout pipes :**

Sl. No.	Particular	Inlet	Outlet	Over flow	Washout
1	Dia of pipe (mm)	400	500	400	100

**3.9.1** The tank shall have C.I. D/F class 'B' pipes of sizes mentioned in above table for inlet, outlet, overflow and washout for which necessary, flanged pipes and specials shall be arranged by the contractor himself. The pipe pieces shall be embedded in concrete in bottom dome with water tight joint. The pipes in the vertical portion upto the duck-foot bend shall be approximately 15cm to 20cm above G.L. The duck foot bend shall be placed on CC block of 0.60 x 0.60 m from top of raft foundation to the floor of the tank at the discretion of the Engineer-in-charge. The over flow and washout may be combined at ground level in one masonry chamber of size 1.50x1.50x1.5m size covered with 200mm thick doubly reinforced R.C.C. slab which may be around 3.0m away from the outer edge of the apron.

**3.9.2** The inlet, outlet, washout and overflow pipe and specials shall be fixed vertically along with the column as directed by means of 50x6mm S.S. clamps with S.S. nut bolts. The number of clamps shall be at least two or as decided by the Engineer-in-charge. The contractor shall provide all materials for jointing and clamping arrangement at his own cost. The top edge of inlet and overflow pipe should be upto H.W.L. of tank and the top edge of washout and outlet pipes should be upto low water level. Horizontally over flow and washout pipes should be laid upto disposal chamber and inlet and outlet pipes should be laid upto S.V. chamber which may be kept around 3m away from the outer edge of apron. It also includes the bye pass arrangements with fixing of DI sluice valve and other specials with sluice valve chambers etc. complete.

**3.9.3** Pipes, specials and fittings etc. for inlet, outlet, overflow and washout the contractor shall ensure that no material is defective because if any defect and leakage is found during testing, whether in the joints or otherwise. The contractor shall rectify it or replace the defective material if necessary at his own cost.

**3.10. Apron and Flooring:**

Floor and the apron in continuation all round the columns extending 1.5m from outer edge of the columns shall be constructed consisting of 40mm thick P.C.C. 1:2:4 with coarse sand and 20mm gaugestone ballast over laid on P.C.C. 1:4:8 with 4cm gauge stone ballast and coarse sand laid in pannels of sizes not more than 1x1m with 5mm thick glass strips. The apron all around the tank shall be guarded with a garland of single brick on edge laid radially in 1:4 cement sand mortar.

### **3.11 Drain:**

15 cm wide P.C.C. 1:2:4 semicircular drain as per departmental type design will be constructed all round the apron and from collection point of apron to disposal chamber.

### **3. 12 Painting Colour Washing:**

All exposed surfaces of mild steel work, such as railing, ladders, doors and windows and inlet, outlet, washout, and over flow pipes etc. shall be painted with two coats of approved anticorrosive paint over one coat of metal primer.

All exposed surfaces of concrete work shall be painted with three coats of approved cement paint such as super snowcem as directed by the Engineer. Colour of paint shall be decided by the Engineer.

Exposed surface will include the bottom surface of the bottom dome in all cases, the entire surface of concrete, except that which is below the ground or within the water containing part of the work, shall be treated as the exterior surface.

### **3.13. Testing of Tank:**

The contractor shall be responsible for the water tightness and stability of complete tank structure and no leakage or seepage in any part of the tank or pipe work shall be allowed. The contractor shall make up all arrangements at his own cost for the filling up of the water in the tank for testing.

The arrangement will include the source of water which may be the municipal water supply or a temporary/shallow tube well, the pumps electrically operated or diesel operated and temporary piping for conveyance of water from the source to the tank.

The contractor shall fill the tank as many times till the satisfaction of the Engineer.

The tank body if left dry for a long period shows cracks on outer and inner surfaces of water retaining portion. The contractor will ensure that if the tank is not being used for a long period then it should be left filled with water.

## **4.0 TESTING OF PIPELINE, VALVES ETC.**

After the pipes and fittings are laid, jointed and the trench partially backfilled except at the joints the stretch of pipe line as directed by Engineer shall be subjected to pressure test and leakage test. Where any section of the pipeline is provided with concrete thrust blocks or anchorages, the pressure test shall not be made until at least five days have elapsed after the concrete was cast. All arrangements required to ensure availability of water, for sectional

testing purpose shall be made by the contractor at his cost.

The contractor shall be free to choose a length of section for taking up sectional testing work, which should be between 500 m to 1000 m for the ease of working. The contractor is suggested to follow the instructions of the Engineer regarding the test procedure, test pressure, lengths of sections for testing etc. Each section of the pipe shall be tested for water tightness of the pipeline.

The pipes are tested by plugging upper end of the pipe with a provision for an air outlet pipe with a stopcock. The water is filled through a funnel connected at the lower end provided with a plug. Each section of the pipe line shall be slowly filled with water and all air shall be expelled from the pipe by tapping at points of highest elevation before the test is made plugs inserted after the tests have been completed. The specified test pressure, based on the elevation of the lowest point of the line or section under test and corrected to the elevation of the test gauge, shall be applied by means of a pump connected to the pipe as directed by Engineer.

All the arrangements for the tests required for supply of water for testing, pipe specials, fittings for blanking of the pipe ends, instruments, labour, tools and plant etc. shall be arranged by the contractor himself at his own cost. The rate quoted by the contractor for laying and jointing of the pipes shall be deemed to be inclusive of the cost of testing of pipes.

The exposed joints shall be carefully examined and all such joints showing visible leaks shall be recalculated until water tight. Any cracked or defective pipes and fitting in consequence of this pressure test shall be removed and replaced by sound material by Contractor at no extra cost to Engineer and the test shall be repeated to the satisfaction of the Engineer. The Contractor shall maintain on site, a record book of all tests carried out and will hand over a certified copy of the same to the Engineer at the time of completion of the works.

The field test pressure to be imposed should be not less than the maximum of the following :

- (a)  $1^{1/2}$  times the maximum sustained operating pressure.
- (b)  $1^{1/2}$  times the maximum pipe line static pressure.
- (c) Sum of the maximum sustained operating pressure and the maximum surge pressure.
- (d) Sum of the maximum pipeline static pressure and the maximum surge pressure, subject to a maximum equal to the work test pressure for any pipe fittings incorporated.

Maximum working pressure at field shall not be less than two thirds of the works test pressure maintained, for the field test pressures are less, the period of test should be at least 24 hours, the test pressure being gradually raised at the rate of  $1\text{kg/cm}^2/\text{min}$ .

During sectional testing of pipeline, if drop of pressure occurs, the quantity of water added in order to re-establish the test pressure shall be measured and it should not exceed 0.1 litre per mm of pipe diameter per km. of pipeline per 24 hours for 30 m head of pressure applied.

The pipeline will be tested during maintenance period also wherein the maximum loss of water due to leakage would not be allowed to exceed

$$qL = ND \sqrt{P/115}$$

where

qL	=	Allowable leakage in cm <sup>3</sup> / hour
N	=	Number of joints in the length of the pipeline
D	=	Diameter in mm
P	=	Average test pressure during the leakage test in kg/cm <sup>2</sup> .

Should any test of pipe laid indicate leakage greater than that specified above, the defective pipe(s) or joint(s) shall be repaired/replaced by Contractor at no extra cost to Engineer until the leakage is within the specified allowance. Necessary equipments and water used for testing shall be arranged by Contractor at his own cost. Damage during testing shall be Contractor's responsibility and shall be rectified by him at no extra cost to Owner/Engineer. Water used for testing shall be removed from the pipe and not released in the excavated trenches. After the tests mentioned above are completed to the satisfaction of Engineer, the backfilling of trenches shall be done as per specifications in layers. Water for testing of pipeline shall be arranged by Contractor at his own cost.

**5: DISMANTLING OF ROAD**

Excavation of Asphalt / Concrete Road Portion:

Where it is required to install works under existing asphalt or concrete pavement (including roads, driveways and sidewalks) by means of an open cut trench, the Contractor shall saw cut the pavement to ensure that when the trench is excavated, the excavated portion of the pavement breaks cleanly away from the portion of the pavement which is not to be disturbed. When it is required to install works under gravelled roads or driveways, the gravel shall be removed from the road surface prior to excavation, stockpiled, and replaced subsequent to backfilling. The trench shall be excavated with vertical walls. Any damage to pavement beyond the allowed trench width (over break) shall be restored to the original condition by the Contractor at his own expense.

Excavation of Paver Block Portion:

The paver blocks of the road should be carefully removed from the road surface manually. The removed paver blocks should be kept in stack in nearby place. After removing the blocks, the soil is excavated for pipe laying as per the requirement.

**6: REINSTATEMENT OF ROADS**

**Asphalt Roads**

The reinstatement of road structures shall be carried out as soon as practicable after backfilling with selected excavated material. The depth and type of reinstatement shall be as per UP PWD specifications

Detail of Layers	Size	Thickness
GSB-G1 one coat	90-40mm	12.5cm
GSB-G2 one coat	45-63mm	7.5cm
GSB-G3 one coat	22.5-53mm	7.5cm

BM	one coat	-	7.5cm
SDBC	one coat	-	2.5cm

The finished levels of the completed reinstatement shall conform to adjoining carriage way surface. Reinstatement of wearing courses shall match as nearly as practicable the color and other characteristics of the existing surface.

The contractor shall be using the public roads for the transportation of pipe and other material. If during the course of use the road is damaged, repairs shall be contractors liability with no claims from the employer.

### **Concrete Roads**

The reinstatement of road structures shall be carried out as soon as practicable after backfilling has been completed. The depth and type of reinstatement shall consist of the following:

Backfilling the trench with selected excavated material.

Plain Cement concrete (1:4:8) using 40 mm metal with concrete mixture, 100mm thick.

Construction of unreinforced, plain cement concrete (1:2:4) pavement, minimum 100 mm thickness over prepared sub base, with OPC cement, with 25mm and down size graded granite metal coarse aggregates and fine aggregates. with super plasticizer @ 3liters confirming to IS9103-1999 reaffirmed-2008, mixed in a concrete mixer of not less than 0.6cum capacity and appropriate weigh batcher as per approved mix design, laid in approved fixed side form work. Spreading the concrete with shovels, rakes, compacted using needle, screed and plate vibrators and finished in continuous operation including provision of contraction and expansion, construction longitudinal joints, joint filter, separation membrane, sealant primer, joint sealant, admixtures as approved, curing compound, finishing to lines and grades as per drawing complete as per specifications.

In case the existing road is constructed with RCC the steel is required to be reinforced to match the design and specification of existing road.

### **Interlocking Tile Roads**

The reinstatement of road structures shall be carried out as soon as practicable after backfilling with selected excavated material has been completed. The depth and type of reinstatement shall consist of the following:

Plain Cement concrete (1:4:8) using 40 mm metal with concrete mixture, 100mm thick.

Providing and laying 100mm thick factory made rubber moulded cement concrete interlocking paver block of M -30 grade made by block making machine with strong vibratory compaction and of approved size and design/ shape laid in required colour and pattern over 50mm thick compacted bed of sand, filling the joints with sand etc. all complete as per the direction of Engineer-in-charge.

## DESIGN PARAMENTER OF CWR CUM PUMPING STATION / ZPS

### Design Standards

All designs shall be based on the latest Indian Standard (I.S.) Specifications or Codes of Practice. The design standards adopted shall follow the best modern engineering practice in the field based on any other international standard or specialist literature subject to such standard reference or extract of such literature in the English language being supplied to and approved by the Engineer.

### Design Conditions for Underground or Partly Underground Liquid Retaining Structures

All underground or partly underground liquid containing structures shall be designed for the following conditions:

- (i) Liquid depth up to full height of wall including free board: no relief due to soil pressure from outside to be considered;
- (ii) structure empty (i.e., empty of liquid, any material, etc.): full earth pressure and surcharge pressure wherever applicable, to be considered;
- (iii) partition wall between dry sump and wet sump : to be designed for full liquid depth up to full height of wall;
- (iv) partition wall between two compartments : to be designed as one compartment empty and other full;
- (v) structures shall be designed for uplift in empty conditions with the water table at HFL
- (vi) walls shall be designed under operating conditions to resist earthquake forces from earth pressure mobilisation and dynamic water loads;
- (vii) Underground or partially underground structures shall also be checked against stresses developed due to any combination of full and empty compartments with appropriate ground/uplift pressures from below to base slab. A minimum factor of 1.2 shall be ensured against uplift or floatation.
- (viii) All the liquid retaining structures shall be designed as per IS 3370.
- (ix) Movement of underground water & its effect on design & construction should be accounted for.
- (x) All the load cases, critical load combinations & necessary boundary conditions during & after construction should be accounted for.

### Design & Construction Requirements

The following are the design requirements for all reinforced or plain concrete structures:

- a) All blinding and leveling concrete shall be a minimum 100 mm thick in concrete grade M15.
- b) For all Water retaining reinforced concrete structures, concrete shall be of a minimum M30 grade and for all other reinforced concrete structures, reinforced concrete shall be of a minimum M20 grade. Maximum aggregate size shall be 20 mm for all the RCC works. Surface of the water retaining structure including roof slab of CWR and headroom of staircase shall be coated with polyurethane coating.

- c) The reinforced concrete for reinforced concrete structures shall have a minimum cement content of 400 kg/m<sup>3</sup> with a maximum 20 mm size aggregate. Reinforced concrete shall have minimum slump of 100mm with maximum water cement ratio of 0.45.
- d) The reinforced concrete for pile foundation (if selected) shall have minimum cement content of 450 kg/m<sup>3</sup> with maximum 20 mm size aggregate with minimum M25 grade of concrete shall be used with minimum slump of 150mm and maximum water cement ratio of 0.50.
- e) In case of pile foundation, minimum diameter of pile shall be 450mm and piling work shall be carried out as per IS-2911 (relevant part). Top of the concrete in the pile as cast shall be above the cutoff level by 0.75 meter (minimum) to remove all laitance and weak concrete and to ensure good concrete at cutoff level.
- f) The minimum clear cover to all reinforcement including stirrups and links shall be 45mm for all water retaining structures. The general requirements shall be as per IS: 3370 and all the water retaining structures including roof slab shall be designed as per IS codes.
- g) The minimum diameter of link or spiral in pile foundation shall be 8mm and spacing of spiral shall not be more than 200mm. The longitudinal reinforcement shall project 50 times its diameter above cutoff level.
- h) The amount of reinforcement in each of the two directions at right angles within each surface zone should not be less than 0.35% of the surface zone cross section for liquid retaining structures. For slabs, minimum of 8mm dia bars shall be used to avoid any deformation of lesser diameter bars under loads prior to construction.
- i) The minimum cover to the main reinforcing bars for different members for non-water retaining structures shall be as follows unless stated otherwise:
- |   |       |
|---|-------|
| Slab (Floor, Roof, Canopy, and Staircase) | 25mm  |
| Beams (Sides, Bottom & Top)               | 30mm  |
| Columns                                   | 40mm  |
| Pedestals (in contact with earth)         | 50    |
| mm Basement wall, retaining walls         |       |
| i) Face in contact with earth             | 40 mm |
| ii) Interior face                         | 30 mm |
| Foundations                               | 50 mm |
| Floorings                                 |       |
- j) Height of pumping station shall be minimum 6.5 m.
- k) Flooring of pumping station and top surface of slab of reservoir shall be furnished with 40mm thick kota stone
- l) For reinforced concrete structures, reinforcement shall be HYSD Steel of grade Fe 500D.
- m) All buildings shall have a minimum 1 meter wide, 100 mm thick plinth protection paving in M15 grade concrete with nominal reinforcement. All plinth protection shall be supported on well compacted strata.
- n) All pipes and ducts laid below the structural plinth and road works shall be surrounded with

- concrete of grade M15.
- o) Detailing of the reinforcement and sizing of structural members shall be done as per latest IS-13920.
  - p) Any structure or pipeline crossing below roads shall be designed for Class 'A' of IRC loading.
  - q) Sliding layer or slip layer shall be provided between sub base and structural slab (Raft). Polythene sheets of 1000 gauge shall be provided as sliding layer as per IS specification.
  - r) Water tightness testing of water retaining structures shall be done in accordance with IS: 3370 (Part I). It is described in Clause 5.31 under this Part-5. The depth of water for testing shall be upto the soffit of the covering slab.

The following minimum thicknesses shall be used for different reinforced concrete members, irrespective of design thicknesses:

(i) Walls for liquid retaining structures	:	250 mm
(ii) Roof slabs for liquid retaining structures mm (Other than flat slabs)	:	150
(iii) Bottom slabs/Raft for liquid retaining structures	:	250 mm
(iv) Floor slabs including roof slabs, walkways, Canopy slabs	:	125 mm
(v) Walls of cables / pipe trenches, Underground pits etc.:	:	150 mm
(vi) Column footings	:	300 mm
(vii) Parapets, chajja	:	100 mm
(viii) Precast trench cover	:	75 mm

#### **Samples and Tests of Materials**

The Contractor shall submit samples of such materials as may be required by the Engineer and shall carry out the specified tests directed by the Engineer at the Site, at the supplier's premises or at a laboratory approved by the Engineer.

Samples shall be submitted and tests carried out sufficiently early to enable further samples to be submitted and tested if required by the Engineer.

The Contractor shall give the Engineer seven days' notice in writing, of the date on which, any of the materials will be ready for testing or inspection at the supplier's premises or at a laboratory approved by the Engineer. The Engineer or Engineer's representative shall attend the test at the appointed place within seven days of the said date on which the materials are expected to be ready for testing or inspection according to the Contractor, failing which the test may proceed in his absence unless instructed by the Engineer to carry out such a test on a mutually agreed date in his or his representative's presence. The Contractor shall in any case submit to Engineer, within seven days of every test, such number of certified copies (not exceeding six) of the test results as

the Engineer may require.

Approval by the Engineer, as to the placing of orders for materials or as to samples or tests, shall not prejudice any of the Engineer's powers under the Contract.

The provisions of this clause shall also apply to materials supplied under any nominated sub-contract.

## **PARTICULAR CIVIL REQUIREMENT**

### **Buildings and Structures**

All the building and structure works shall generally comply with the following requirements, unless otherwise specified elsewhere.

1. All building works shall be of reinforced concrete framework.
2. All external walls shall be in solid cement concrete blocks or brick masonry. Concrete Blocks shall be provided as per IS: 2185 (Latest Revision) and shall be 200 mm thick. Brick masonry shall be 230 mm thick. Solid Concrete blocks shall have minimum compressive strength of 5 N/mm<sup>2</sup>.
3. All internal partition walls shall be in solid concrete blocks or brick masonry. Concrete block shall be 100 mm thick and shall be provided as per IS: 2185 (Latest Revision) or Brick masonry shall be 115 mm thick. Solid Concrete blocks shall have minimum compressive strength of 5 N/mm<sup>2</sup>.
4. (a) Finishes to concrete liquid retaining structures shall be :
  - F1 External surfaces, buried
  - F2 External surfaces exposed and up to 300 mm below ground level
  - F2 Internal surfaces(b) Finishes to other concrete structures shall be :
  - F1 Buried
  - F1 Exposed, where plastering is specified
  - F2 Exposed
5. All internal masonry surfaces finish shall have 12 mm thick plain faced cement plaster in cement mortar (1:4) with neat cement finish on top. Over this, one coat of primer and two coats of plastic emulsion paint of approved quality and shade shall be provided.
6. All external masonry surfaces and concrete surfaces with rough board finish shall have 20 mm thick sand faced cement plaster in two coats, base coat 12 mm thick in cement mortar 1:4 and finishing coat 8 mm thick in cement mortar 1:4. Waterproofing compound of approved make and quality shall be added to the cement mortar in proportions as specified by the manufacturer.
7. All external surfaces above ground level shall have one coat of primer and two coats of waterproof cement based paint of approved quality and shade. A coat of silicone water repellent paint shall also be applied thereon.
8. The skirting in Pump House building shall be 20 mm thick mirror polished, machine cut granite slab of approved shade and pattern placed in cement mortar (1:4). Skirting for 150mm height shall be provided in these areas.

9. 50mm thick cement flooring over base of 150 mm thick PCC shall be provided in the Pumphouse.
10. All staircases shall have 25 mm thick chequered mosaic tiles for treads and 25 mm thick plain mosaic tiles of approved shade for risers set in cement mortar or lime mortar to give an overall thickness of 50 mm.

All concrete stairs shall have aluminium nosing over 2 mm thick rubber strip of width same as nosing for the full length of the tread. Nosing shall be fixed with countersunk screws.

Stairways with 1.5 m width shall be provided to permit access between different levels within buildings. Cast Iron rungs or steps shall be provided on the inner side walls of all the water retaining structures at 300mm spacing inside the valve chamber.

11. All floor cut-outs and cable ducts, etc. shall be covered with precast concrete covers in outdoor areas and mild steel chequered plates of adequate thickness in indoor areas. All uncovered openings shall be protected with SS 304 hand railing.
12. All staircases shall be provided with Stainless Steel 304 hand railing for protection.
13. The reinforced concrete roofs shall be made waterproof by application of an approved roof polythene / bitumen membrane as approved by Engineer. The finished roof surface shall have adequate slope to drain quickly the rain water to R.W down take inlet points.
14. For roofing drainage, cast iron rainwater down take with C.I./uPVC. bell mouth and C.I./uPVC grating at top shall be provided. For roof areas up to 40 sq.m minimum two nos. 100 mm diameter down take pipes shall be provided. For every additional area of 40 sq.m or part thereof, at least one no. 100 mm dia. Down take pipe shall be provided.
15. Top surfaces of chajjas and canopies shall be made waterproof by providing a screed layer of adequate slope or application of an approved roof membrane and sloped to drain the rainwater.
16. Building plinth shall be minimum 600 mm above average finished ground level around building.
17. All doors, windows, rolling shutters shall have lintels above. RCC Chajja protection to lintels on external walls shall be such as to prevent the rain water splashing into the building. Chajja projection of minimum 750 mm for rolling shutters, 600 mm for doors and 450 mm for windows shall be provided to prevent the rain water splashing into the building. Chajja shall be projected 150 mm on either side from size of doors/windows/rolling shutters.
18. At least one cupboard shall be provided in the wall of each room of all buildings as per the instruction given by Engineer. These wall cupboards shall be covered with steel gates; 25 mm thick Kota stone slab shall be provided as shelf of the wall cupboard. The stores rooms shall have at least complete two adjacent walls covered by selves. The selves of one side wall shall have steel gates as mentioned above. The depth of the selves shall be at least 600 mm in the rooms and 750 mm in the stores and laboratory.
19. All windows and ventilators shall have 25 mm thick Granite stone sills bedded in cement mortar (1:3).
20. All doors in office building and guest house, windows and ventilators in all the buildings shall be made of aluminium conforming to latest version of IS: 1948. All fixtures for doors, windows and ventilators shall also be of aluminium and shall be provided as per IS specifications. Aluminium grills shall be provided in all the windows. Doors shall be in two panel and both panels shall be

glazed/unglazed. Minimum weight of aluminium doors & windows shall be as follows

I. Single Glazed Window : (Weights indicated shall be for aluminium)

a) Openable

Outer Frame : Weight 0.70

kg/RmtShutter Frame : Weight 0.97

kg/RmtIntermediate Mullion : Weight 0.97

kg/RMtBeading : Weight 0.31

kg/RmtFixing Louvers windows/ventilators

Outer Frame : Weight 0.46 kg/Rmt

II. Double Glazed Window

Outer Frame : Weight 0.72

kg/RmtShutter Frame : Weight 0.97

kg/RmtIntermediate Mullion : Weight 0.97

kg/RMtBeading : Weight 0.31

kg/Rmt

III. Sliding Windows

Bottom & Top Frame : Weight 0.70 kg/m

Shutter Frame : Weight 0.42

kg/mInterlocking Section : Weight

0.47 kg/m

IV. Aluminium Door

Outer Frame : Weight 2.508

kg/RmtShutter Frame : Weight 2.508

kg/RmtBottom Stile : Weight 2.508

kg/Rmt

Glazing shall be 5.5 mm thick glass.

21. Doors in pump house building shall be solid core flush 35 mm thick single leaf/double leaf wooden door with all copper fittings and frame of the doors shall be made up of steel angle section 50X50X6mm.
22. Openings of the windows & ventilators shall be designed considering the number of air changes and other parameters as per design guidelines of ventilation.
23. Ventilator shall also be provided where height of floor is more than 3m. All windows and ventilators shall have wire mesh. Frame of doors, windows and ventilators shall be of aluminium of standard rolled section. Doors, Windows and Ventilators shall be of size as per schedule to be submitted by the Contractor for approval of Engineer. The minimum size shall be as per below: Door of opening size 1.2m x 2.1m

Door of opening size 0.75m x 2.1m for  
toilets Glazed windows of minimum size  
1.2m x 1.2m Ventilators of minimum size

0.6m x 0.6m

24. Rolling shutters shall be made of 80 x 1.25 mm MS laths. Rolling shutter shall be of minimum size 3m wide x 5.0m high. Rolling shutter shall be provided wherever required.
25. All structural steel members shall be painted with two coats of enamel paint over one shop and one field coat of red oxide zinc chrome primer.
26. Kerbs to be provided below the hand railing on the catwalks/pathways should be as per relevant sections of Factory Act.
27. Appropriate sign boards of approved material indicating the function of the particular system is required to be provided by the Contractor to the approval of Engineer.
28. The design of buildings shall reflect the climatic conditions existing on the site.
29. All buildings shall as far as possible permit the entry of natural light, and the use of glazed panelling shall be kept to a minimum and preference given to wall openings protected by weather canopies.
30. Emergency exit doorways shall be provided from all buildings in order to comply with local and international regulations. Stairways and paved areas shall be provided at the exit points.
31. All the walkways shall have minimum 1.0 m width and shall be covered with mosaic tiles and hand railing shall be provided on both side of walkway.
32. Hand railings shall be made up of Stainless Steel 304 conforming to ASTM A-240M. Height of railing not less than 1200mm. Hand railing shall be provided in the pumphouse. The distance between 2 vertical posts shall not be more than 01.5 metres. Outer diameter of vertical pipe shall be 50mm with 2mm pipe thickness. Two rows of horizontal pipes of 25mm outer diameter with 2mm pipe thickness shall also be provided. Mechanical properties of stainless steel Grade-304 shall be as follows:

Grade	Tensile Strength (MPa) min	Yield Strength 0.2% proof (MPa) min	Elongation (% in 50 mm) min	Hard Ness	
				Rockwell B (HR B) Max	Brinell (HB) Max.
304	515	205	40	92	201

33. Suitable wall openings, erection openings, external access stairs & platforms to facilitate easy movements.
34. Overflow pipe shall be designed and shall be 1.25 times more than inlet pipe cross section area.
35. Adequate plinth protection shall be provided for CWR and pumphouse.
36. Adequate lighting points shall be provided inside the ceiling of CWR for maintenance and operation purpose.
37. Staircase head room dorrs shall be provided with locking arrangement.

### Approach Road Works

A comprehensive approach shall be provided to approach pumphouse for necessary maintenance, delivery of consumables and personnel access. All roads shall be of asphalt macadam and minimum 5 meters wide. Vehicular access shall be provided for all the structures and buildings. All roads shall be provided with drainage and shall be constructed to prevent standing water.

Paved pedestrian access ways shall be constructed on either side of the road. Damage to any existing roadson account of their use by the Contractor shall be made good to the satisfaction of the Engineer.

Space for proper turning of the heavy vehicle shall be considered while designing the road.

### **Coating Specification**

I Coating/painting Specifications for RCC internal surface of CWR:

The Contractor shall employ specialist firms approved by the Engineer for the supply and laying of food grade epoxy linings. The Epoxy shall made up of minimum 2 coat to provide minimum thickness of 170 microns.

II Coating/ Painting specifications for RCC external surface of CWR :

1<sup>st</sup> Coat of Moisture cured MIO ( Micacious Iron Oxide ).: 25-30 microns  
2<sup>nd</sup> Coat of Moisture cured Tar , Black in color : 30 microns.

3<sup>rd</sup> coat of Moisture Cured Tar, Brown color : 30 microns.

**Total DFT : 90 microns.**

**Application :** Brushing/Spray.

### **Hydraulic Testing of Liquid Retaining Structures**

In addition to the structural test of structures, the liquid retaining structures shall also be tested for water tightness test at full supply level as described in 10.1.1,10.1.2 and 10.1.3 of latest revision of IS 3370 (Part I).

On completion of the structure and before its commissioning, the contractor shall carry out a water tightness test for the maximum water head condition i.e. with the water standing at Full Supply Level (FSL). This test shall be carried out preferably in dry season in accordance with the procedure given below:

The water tightness test shall be carried out during wet testing period when the construction of liquid retaining structure is completed and when it is possible to fill the structure and ensure that uniform settlement of the structure as a whole or as directed by the Engineer. Before the filling operations are started the structure shall be inspected by the Engineer/Engineer's Representative and the Contractor's Representative and the condition of surfaces of walls, contraction joints shall be noted and it shall be ensured that the jointing material filled in the joint is in position and all openings are closed. The Contractor shall make necessary arrangement for ventilation and lighting of the structure by way of floodlights, circulators etc. for carrying out proper inspection of the surfaces and inner conditions if so desired by the Employer. Records of leakages starting at different levels of water in the reservoir, if any, shall be kept.

The liquid retaining structure once filled shall be allowed to remain so for a period of seven days before any readings of drop in water level are recorded. The level of the water shall be recorded against the subsequent intervals of 24 hours over a period of seven days. The total drop in

surface level over a period of seven days shall be taken as an indication of the water tightness of the structure, which for all practical purposes shall not exceed 40 mm. Also there shall be no indications of the leakages around the opening or on the walls.

If the structure does not satisfy the condition of test and the daily drop in water level is decreasing, the period of test may be extended for a further period of seven days and if the specified limit is then reached the structure may be considered as satisfactory.

The external faces of structure shall not show any signs of leakage and shall remain apparently dry over the period of observation of seven days after allowing a seven day period for absorption after filling.

In case the drop in level exceeds the permissible level limit and signs of leakage with the stipulated period of test, the Contractor shall carry out such additional works and adopt such measures as may be directed by the Engineer/Engineer's Representative to reduce the leakage within the permissible limits. The entire rectification work that shall be carried out in this connection shall be at the Contractor's cost. The water required for subsequent testing shall be supplied to the Contractor free of cost, if the same is available near the site. Contractor shall have to make arrangement for filling emptying the structure at his own cost.

If the test results are unsatisfactory, the Contractor shall ascertain the cause and make \

ll necessary repairs and repeat the water retaining structures test procedures, at his own cost. Should the re-test results still be unsatisfactory after the repairs, the structure will be condemned and the Contractor will dismantle and reconstruct the structure, to the original specification, at his own cost.

During testing and during defect liability period the impression marks created due to seepage shall be rectified and made good.

No separate payment shall be made for water tightness test and the cost thereof shall be deemed to be covered in the rates quoted for the works.

### **Testing on Piles**

Only in case of pile foundation, two types of load tests are to be conducted on the piles i.e. initial load test and routine load tests. These tests shall be carried according to IS: 2911 (Part-IV). Contractor shall take prior approval of the methodology of load tests to be conducted on the pile.

Initial load test shall be carried out to assess the safe load carrying capacity of the pile before the start of installation of the working piles. Initial load test includes two types of tests i.e. vertical load test and lateral load test. Test pile shall be installed by contractor as per the instruction given by Engineer. A minimum period of four weeks shall be allowed between the time of pile casting and testing of the pile.

Routine load tests shall be conducted to verify the load carrying capacity of the working piles.

**Integrity Tests of Piles:** All the piles after testing shall be tested ultrasonically for integrity. Ultrasonic Testing shall be done on all the piles. Any pile which does not pass the test shall be defective and rejected. All the defective piles shall be redesigned and replaced by the contractor.

### **Level indicator**

Level indicator of 6m shall be provided with float type mounted with frictionless pulley in each tank.

### **Leveling of Site and Landscaping**

The excavated portion below ground level shall be completely filled by earth and compacted to 90% proctor density and as per backfill specifications. No portion of the ground inside the premises of the CWR shall be less than formation level (0.6 m below basement level of Pump house) and as directed by the Engineer.

The site shall be landscaped once the Works are substantially complete. Landscaping area shall be marked in layout plan.

Landscaping shall include planting of suitable trees and development of grassed areas. Landscaping in general shall meet ecological and environmental conditions of the site. Road widths shall determine the size of the tree height and spread to be selected for planting. Trees suitable for local conditions shall be selected. Medicinal and fruit trees shall be avoided. Landscaping shall be maintained in good condition till the completion of contract.

### **HYDRAULIC TESTING OF ESR:**

On completion of work, hydraulic test or water tightness test shall be given as per standard specifications. The Contractor shall make required arrangement of water for testing. Since, this is water retaining structure; Contractor shall give a satisfactory hydraulic test of the tank. This test shall be considered water tightness test and accepted if the structure appears bone dry from outside after filling with water upto full supply level and the drop in water level is not more than 40 mm in 7 days. If during testing any damage occurs to the structure, it will be the responsibility of the Contractor to rectify until satisfactory water tightness test is given on completion of work. The filling of the reservoir shall be carried out gradually at the rate not exceeding 30 cm rise in water level per hour and shall not exceed 2.0 meter in 24 hours and total period of 72 hours. Records of leakage starting at different level of water in the reservoir if any shall be kept. The reservoir once filled shall be allowed to remain filled for seven days before any readings of drop in water level are recorded. The level of the water shall be recorded again at subsequent intervals of 24 hours over a period of seven days. The total drop in surface level over a period of seven days shall be taken as an indication of the water tightness of the reservoir, which for all practical purposes shall not exceed 40 mm. If the structure does not satisfy the condition of test and the daily drop in water level is increasing the period of test may be extended for a further period of seven days and if the specified limit is then reached the structure may be considered as satisfactory. If even after extending the period of test, the drop is more than permissible, the Contractor should empty the reservoir, rectify the defects in tank, by water proof treatment such as cement grouting or Epoxy grouting whenever necessary and give the water- tightness test till the drop in level is within permissible limit.

## **PARTICULAR REQUIREMENTS FOR CIVIL/STRUCTURAL REHABILITATION**

### **1. Details of Work Activities applicable to the Plant**

The detailed scope of work applicable for rehabilitation of OHT shall be generally as follows but not restricted to the lists indicated. The guidelines indicated here for the bidders are brief and they should refer to the individual product specifications along with the Method Statements attached.

1. Surface cleaning, sealing of external and internal cracks/porous in concrete structure by epoxy Grouting and cement grouting.
2. GI Hand railing repair including partly replacement of corroded pipes including vertical pipe ends in concrete which are damaged due to corrosion.
3. S.S ladder from opening of top dome to bottom dome.
4. Hydro Testing of OHT.
5. Cement/ Epoxy Grouting for water tightness if leakage observed during hydrotesting.
6. The food grade epoxy coating of FOSROC / Ciba-Geigy or reputed brand on inside surface area of water container after testing for water tightness.
7. Dismantling and re-construction of floor, apron, inlet, outlet, overflow and washout valve chambers.
8. Replacement of all sluice valves and construction of chamber (Inlet, Outlet & Washout).
9. Replacement of Water Level Indicator.
10. Two coat apex painting over one coat primer of approved colour after finishing of RCC surface with grinder, repair of pin holes, unevenness etc.

## **2. Preliminary Work**

1. Hydro Testing of Existing Water Retaining Structures:
2. All water retaining structures shall be hydro Tested as per provision in clause 12 of IS 3370 (Part- 1) 2009/Latest. The structures shall be filled with water and dewatered at the contractor's cost. In case considerable leakage of water is observed than cement grouting has to be done.
3. Emptying and Cleaning of OHT inclusive of inside and outside surface complete using pressure jetting machine at a pressures of minimum 6.0 kg/cm<sup>2</sup>. Subsequent to cleaning by power jetting, if necessary manual means such as brooms, wire brush may have to be used for ensuing full and final clear concrete surfaces. High Pressure Water Jetting Machines are recommended for these applications. Water and power required for cleaning etc. have to be arranged by contractor.
4. For exterior of tanks and building above the Natural Ground Level the same shall be cleaned by power Jetting. If Concrete and Plaster are damaged then the same shall be repaired using bonding chemical.
5. The damaged concrete visible/or spalled shall be safely dismantled and the exposed Reinforcement, if any, shall be de-scaled/cleaned by simple mechanical/chemical means such as wire brushing etc.
6. Contractor/Bidder shall follow all standard safety regulations such as safety belts/helmets/ nets/gas breathing kits, Safety Nets etc to ensure complete safety of life and property while working in hazardous areas.

## **3. Rehabilitation of Reinforced Concrete**

Brief Details of work Activities for Repair and Rehabilitation of the Over Head Tank.

1. The Reservoir shall be cleaned of all the muck and debris.

2. The weak concrete or damaged areas not visible to the eye which however need to be identified and dismantled by tapping etc. The same can be marked and dismantled by using light hammers/chisels etc.
3. All exposed reinforcement shall be cleaned by wire brushing and suitable Bonding epoxy in different areas shall be applied as per manufacturer's recommendations. Providing and fixing new reinforcement steel as and when applicable by treating the same with cement/polymer based anti corrosive coatings.
4. Cement Grouting with suitable chemicals of walls/base slabs/launders of WRS by drilling holes with approximate 1.5m centre staggered. The area shall be grouted through the nozzle using a grout pump.
5. Grouting of RCC members using low viscosity epoxy resins with long pot life for crack injection in structural cracks of columns/beams, slabs etc. Injection Grouting shall be done using High pressure Grout pumps to ensure full penetration of the epoxy and enhance the structural integrity of the Concrete Section.
6. All the joints between the Base slab and wall shall be treated with Acrylic Copolymer Bandages and treated with Acrylic elastomeric waterproof coatings if required.
7. The entire walls shall be again structurally repaired and grouted wherever necessary after removing the existing Coatings, much or old plaster if any.
8. The roof slab shall be inspected for any damage/major cracks by tapping. Major Cracks if found on the Roof Slab of the OHT or loose cover is found, remove all loose cover & clean and apply suitable bonding chemical wherever through cracks are seen, suitable epoxy grouting is to be done. Repair of RCC walls etc shall be done in grade of M30 using formwork and new reinforcing steel wherever required using bonding chemicals.
9. All insides area of the CWR, Roof Slab including and the Wall up to 500 mm below the FSL shall be treated with 2 coats of food grade Epoxy having DFT each of 150 micron to protect the Concrete from the Corrosive action of the Chlorine Gas.
10. The damaged Brace Beams shall be repaired, restored and retrofitted. The Repairs shall be done using high strength Repair mortars, Restoration shall be done by injection of high viscosity epoxies.
11. The structure shall be finally be treated with Cement Paints after thorough cleaning (Structural repair from Outside). The Paints shall have special additives and plasticizers to enhance the Performance of the same.
12. Plastering of walls, beams/columns/slabs using bonding material for old surfaces. Repair Patch Plaster work wherever required. All Plasterwork shall be done only after the RCC Repairs have been done using bonding material.
13. Plastering of all existing buildings using plaster made of cement sand in the ratio of 1:4 shall be mixed at site and not pre-packed finely graded silt free sand as per IS Code specifications shall be used.
14. Cleaning the surface, repair of RCC slab and application of a smooth cementitious Screed 10 to 15mm for application of self adhesive SBB membrane 1.5mm thick having a polyethylenecoating at top of 105g/sqm on a primed surface, followed by a Screed course of average 40 mm thick (roof is accessible and usable) laid to slope as per the building layouts.
15. Protection of RCC walkways platforms etc. by first Repair of the damaged edges, corners by Repair Mortars, followed by plugging of blow holes and ensuring smooth line and level.
16. New railings – wherever required shall be GI make 32 inner dia vertical post 900 mm height at 1.5m centres with 2 rows of 25 inner dia GI pipe inclusive of elbows, bends and toe plate in MS 100x 3 mm at bottom. The Rails shall be welded with vertical post.
17. In case the existing Railings are in good condition the same shall be cleaned thoroughly, washed Cleaning the surface using wire brush, water and removing of all existing rust then application of thermoplastic acrylic co-polymers in 2 coats to a DFT of 300 microns of approved shade and color.
18. All damaged, Corroded and Non Operational Rolling shutters shall be dismantled and replaced by New Rolling shutters as per specifications.
19. All damaged and Corroded Doors and windows shall be replaced with New MS doors and windows, matching to the existing sizes, shape design and engineering of the material.
20. Repairing works of Plinth protection shall be done around all Water Retaining Structures or location as specified by the Engineer-in-charge.

#### **4. Rehabilitation of the Clear Water Reservoir**

## 5. MATERIALS

### 5.1 CEMENT (ORDINARY AND PORTLAND)

All Portland Cement for use on the works shall comply in every respect with requirements of the Indian Standard Quality of Cement Specification for Portland Cement as issued and amended from time to time by the Indian Standards Institution. The Portland Cement used in the works shall be manufactured in India and shall be of a make and quality to be approved by the Engineer.

No other make/grade of cement, but that approved by the Engineer will be allowed on the works and the contractor shall not change his source of supply without the approval of the Engineering in writing.

Tests ⇒ Produce test certificates to show that the cement is fully up to the specification and notwithstanding this, the Engineer may at his discretion order that the cement delivered on the work and which he may consider damaged or of doubtful character for any reason whatsoever, must be retested by approved testers and fresh certificates of its soundness produced by the contractor at his sole cost. Cement ordered for re-testing shall be withdrawn

from the work pending the results of re-testing. The decision of the Engineer in this respect shall be final binding on the Contractors.

Stores ⇒ Large stock of cement shall not be kept at the works but sufficient quantities to ensure

continuity of the work. The contractors shall provide and maintain proper and sufficient storage sheds for the cement on the works. The floor of the stores shall be raised at least 9" from the ground in order to protect the bags from moisture. No cement damaged exposure or otherwise will be allowed to be used in work, but shall be removed at once from the site.

Packages ⇒ the cement shall be supplied in sound and properly secure sealed bags, weighing (1 bag) 50 kg. Net. The rates entered in the Bill of Quantities and Rates shall be held to include the cost of haulage to the work housing and protecting from the weather, risks of every kind and all expenses connected with preparing the cement for use and with using it in the work.

### 5.2 Sand

All the sand aggregate shall consist of clean, hard, strong, durable quality of river sand uncoated, well-graded particles when incorporated in the concrete mixture, the fine aggregate shall be free from frost, frozen lumps injurious amounts of dust, mica loam or other deleterious substances.

The sand shall be of river and taken from a source approved by the Engineer. If the Engineer considers if necessary, it shall be washed. The cost of washing must be included in this price for the concrete work.

All sand shall pass through a sieve having meshes not more than (1/4" inch) 6 mm. Wide and if the Engineer shall require it, it shall be screened before use at the

expense of the contractor. In no case shall fine aggregate be accepted containing more than two percent, dry weight, not more than three and half percent by dry volume of clay, loam or silt. If any sample of fine aggregate show more than five percent of clay, loam silt in one hour's settlement, after shaking in an excess of water, the material represented by the sample will be rejected. If necessary, silt test shall be taken by the Engineer.

All fine aggregate shall be stored on the works in such a manner as to prevent the intrusion of foreign matter. The fine aggregate shall conform to IS 383 (latest).

### 5.3 Coarse Aggregate

The whole of the ingredients of the coarse aggregate shall be Quality coarse consisting of crushed rock, gravel or other aggregate material. The particles of coarse aggregate shall be clean, hard, tough, durable material, free from vegetable or other deleterious substances and shall contain no soft flat or elongated pieces. All coarse aggregate shall be stored on the works in such a manner as to prevent the institution of foreign matter. If it is considered necessary, the Engineer may order it to be washed and screened. The contractor shall state in his tender the source from where he will obtain the aggregate and he shall also include in his price the cost of washing. If screening is necessary and the cost shall be borne by the contractor.

The coarse aggregate shall consist of :

Grading of coarse: 1.

1	Metal No.2	$\frac{3}{4}$ " to 1"	20 to 25 mm. Aggregate
2	Metal No. 1	$\frac{1}{4}$ " to $\frac{1}{2}$ "	6 to 12 mm

The whole of the aggregate shall all pass a screen having meshes not greater than 1" (2.54 cm.) square and shall be retained on a screen having meshes  $\frac{1}{4}$ " (6.35 mm)

square. The materials may be tested for voids before the work is commenced and at intervals during the course of construction, as may be necessary and the proportion of the different grades in the coarse aggregate fixed by the Engineer so as to secure a well graded material varying from ( $\frac{1}{4}$ " to 1") 6.35 mm to 25.4 mm. The different grades of the coarse aggregate shall be measured by means of suitable boxes and in such proportion as may be approved by the Engineer.

### 5.4 Water

The water shall be clean and free from injurious amounts of oil, acid, alkali, organic or other deleterious substances. The quality of water added to the materials for making concrete shall be properly under control and must be measured.

### 5.5 Reinforcement

The steel to be used in reinforced concrete work shall comply with the requirements of Indian Standard Specification I.S. No. 43 (Latest).

If any steel does not in the opinion of the Engineer comply with any of the tests

specified in above I.S. code, The Engineer may reject the lot or lots from which the sample or samples taken and the same shall not be used on the works but shall be removed from there.

All steel used for reinforcement shall be free from loose scales or rust, which must be removed with a stiff wire brush. Bars must also be free from oil or paint. The steel should be properly braced, supported and otherwise held in position strictly according to the contract and plans. This shall be looked after with proper care and checked over by a competent foreman personally and finally before pouring the concrete.

All protruding bars from columns, beams and slabs to which other bars are to be applied later on, must be protected from rusting, by a coat of thin neat cement grout. All bending shall be done cold, gradually, evenly and without jerks. A jerky action is likely to snap or crack the steel.

#### 5.6 Polymers

The polymer modifier shall be a modified acrylic based compound. The product shall have minimum solids of 40% + 2%. The polymer shall be capable of being used both as a bonding agent having a pull off bond strength not less than 1 Mpa and also as an additive for preparation of polymer modified repair mortar.

#### 5.7 Repair Materials:

Repair system shall deem to comprise of the following layers:

- 1) Rust inhibition or steel passivator layer
- 2) Bond coat
- 3) Modified mortar
- 4) PAN fibre Reinforced dual shrinkage compensated single component Repair Mortar.
- 5) Surface protection film

All polymeric compounds selected for a repair system shall be manufactured by a single manufacturer, to ensure compatibility. Polymers of different make and manufactured by a different manufacturer shall not be used in a particular repair system. Also all polymers shall be of a single generic. For e.g. When ACRYLIC's area used for one treatment all the polymers used to complete the repair system shall consist of ACRYLIC's only.

They shall conform to standard specified herein

under:- Generic : Acrylics  
Only

Specific gravity @ 30 degree C: : 1.02 to 1.05

Viscosity @ 30 degree C : 28 to 34  
centipoise

Solid content @ 105 degree C : 38 to 42 percent by

weight Shelf life (after container is opened) : 6 to 8  
months

Colour	: Milky White (As per manufacturer)
pH Value	: Greater than 7.0
CI Content	: Zero percent

The manufacturer shall submit an infra ray spectrum of the sample which are submitted for approval. All subsequent supplied shall be randomly tested by infra ray spectrum for consistency. These tests shall be done by third party test house or under direct supervision of the consultant.

#### **5.8 Coal Tar Epoxy**

It shall be high build pitch extended epoxy coating and shall be 100% solids, solvent free, tough abrasion resistance coating.

The product shall exhibit excellent bond strength with substrate exceeding 2.5Mpa as per ASTM D4541.

The product shall be formulated to have high build thickness exceeding 150 microns per coat on average to achieve overall thickness of 300 micron in 2 coats.

The product shall be formulated to resist exposure to accelerated weathering test as per ASTM D4587 and shall not exhibit any flaking or blistering.

#### **5.9 Epoxy**

The Non Toxic High build epoxy coating shall be solvent free, taint free, potable grade protective coating. The product shall exhibit bond strength exceeding 1.5Mpa tested as per ASTM D4541. Product shall be formulated to have a thickness of 200 microns per coat on average to achieve overall thickness of 400 microns in 2 coats. Product shall be approved by CTRI for use in contact with potable water.

### **6.0 Membrane**

#### **WATERPROOFING MEMBRANES FOR FLAT TERRACES:**

Self adhesive elastomeric SBS bitumen based waterproofing membranes with high mechanical performance polypropylene mesh, finish of upper side and easily removable silicone film on underside. Thickness of membrane shall be minimum 1.5mm.

#### **6.1 Polypropylene Fibres: (For Concrete work / Mortar Work)**

The material shall be virgin high tenacity polypropylene mesh fibre and multifilament combination in 10mm length for use in water retaining structures concrete work.

Dosage should be minimum 125gms/bag of concrete as per specified dosage of Consulting Engineer.

The fibres shall be Alkali and Acid resistance, non absorbent, and chemically Inert having a density of 0.93gms/cc and should confirm to ASTM C-1116. Lengths of strands shall be 10mm blended for plaster work Dosages shall be 100g/bag of cement.

## 6.2 Glass Fibres

The Glass fibres shall be Alkali Resistance Glass fibre specially developed for Cementitious Mortars and Concrete Mixes.

They shall be monofilament having diameter of  $14\mu$  and a specific gravity of 2.6, length 12mm and an Aspect ratio of 857:1 and a specific surface area of  $105\text{m}^2/\text{Kg}$ .

Dosage shall be minimum = 85g/per bag of cement but to be decided by the Consulting Engineer in charge.

## 6.3 Plasticizers

The liquid integral waterproofing shall be lignosulporiate Polymer based waterproofing cum plasticizing admixture. The product shall comply with IS 2645:2005 when tested at a dosage of 100ml/50 kg bag of cement. The product must be free of chlorides and shall have a specific gravity of not less than 1.15 and shall comply to ASTM C 494 type A & D.

## 6.4 Prepacked Ready Made Plasters

The Prepacked ready made plasters shall be coarse / fine water resistance mortar for internal / external use.

The blend shall be made of fillers which are silt free precisely graded sand with OP cement as binder and additives to improve workability water retention durability and adhesion of mortar. The blend shall have PP fiber in proportion not exceeding 125gms / 50kg cement and fly ash not exceeding 25% as substitution of cement.

## 6.5 Expansion Joint Sealing Tape

The joint shall be treated with a highly elastic (having elongation > 600%) and shall have a hardness of 80 with special epoxy as adhesives. The expansion tape shall be supported by single component gun graded quality PU sealant followed by a backing material of polyethylene.

Width of expansion joints shall not exceed 150mm. Thickness of joint sealing tape shall be minimum 2mm.

The tape shall have tensile strength exceeding 6Mpa and resistance to cracking exceeding 600N/cm when tested as per DIN 53363.

## 6.6 MATERIAL TESTING

The following test shall be carried out on the following system components: The Polymers used shall conform to the standards stated above.

(I) RUST INHIBITION LAYER:

Aspect	:	Grey powder
Volume, Solids %	:	50+3

Mixed Density	:	2.3Kg/Litre
Mixed Ratio	:	96 (B) 0.4(h)
Pot Life	:	>2 Hrs @ 250C 20 mins @ 250C5 mins @ 400C
Total Zinc Content	:	> 90% by volumeDry Film
DFT per Coat	:	> 50 microns
Application Temp	:	Min 100C Max 40C

(II) BOND COAT:

Bonding Strength	:	Acceptance limit : 2 n/MM2
Air entertainment	:	± 1% in comparison with pure mortar
Cure time	:	10 hours
Viscosity	:	28 to 34 centipoise
Solid content	:	38 to 42% by weight
Colouring consistency	:	Yes

(III) POLYMER:

Aspect	:	milky white liquid
Elastic density	:	1.03 + 0.01 @ 25 C
Solid content	:	=> 40%
Pull out bond stress	:	1Mpa
Fresh wt density	:	2000 to 2200 kg.m <sup>3</sup>
Compressive strength	:	upto 30N/mm <sup>2</sup>
Flexure strength	:	upto 11N/mm <sup>2</sup>

---

Tensile strength	:	upto 6 n/mm <sup>2</sup>
Adhesion	:	excellent to concrete
Resistance to water under	:	no water through 15mm thick test piecepressure ( 30 m head)

(IV) POLYMER MODIFIED MORTAR:

Viscosity	:	28 to 34 centipoise
Solid content	:	38 to 42% by weight
Cure time	:	Max. 48 hours
Air entertainment	:	± 1% comparison with pure mortar
Colouring consistency	:	Yes
Compressive Strength	:	>30 N/mm <sup>2</sup>
Flexural Strength	:	> 6 N/mm <sup>2</sup>
Shrinkage at 35 degrees	:	Crack width < 50
micronsModulus of elasticity	:	20 to 25 Kn/mm <sup>2</sup>

(V) HIGH STRENGTH PAN FIBRE REPAIR MICRO

CONCRETE:Aspect	:	Grey powder
W/P ratio (by weight)	:	0.14
Fresh Wet Density	:	2300 Kg/m <sup>3</sup>
Compressive Strength	:	25Mpa @ 1
day (ASTMC log-7cm cubes)	:	35Mpa @ 3
days		45Mpa @ 7 days
		70Mpa @ 28
		days
Tensile Strength	:	> 4Mpa @ 28 days
Flexure Strength	:	> 9Mpa @ 28
days(ASTMC C 496)		
Water penetration (DIN1048)	:	< 5mm
Coefficient of oxygen diffusion	:	2.58x10 <sup>-8</sup>

(VI) MEDIUM STRENGTH PAN FIBRE MODIFIED MICRO

CONCRETE:Aspect	:	Grey powder
W/P ratio (by weight)	:	0.16
Fresh Wet Density	:	2250 Kg/m <sup>3</sup>
Compressive Strength	:	15Mpa @ 1 day / 25Mpa @ 3 days
		35Mpa @ 7 days / 45Mpa @ 28 days

(VII) HIGH STRENGTH PAN FIBRE MODIFIED REPAIR

MORTAR:Aspect	:	Grey powder
W/P ratio (by weight)	:	0.14
Fresh Wet Density	:	2300 Kg/m <sup>3</sup>
Compressive Strength	:	20Mpa @ 1
day (ASTMC log-7cm cubes)	:	50Mpa @ 3
days		70Mpa @ 28 days

Tensile Strength	:	> 4Mpa @ 28 days
Flexure Strength	:	> 9Mpa @ 28 days (ASTMC C 496)
Water penetration (DIN1048)	:	< 5mm
Coefficient of oxygen diffusion	:	2.58x10 <sup>-8</sup>

(VIII) MEDIUM STRENGTH PAN FIBRE MODIFIED REPAIR

MORTAR: Appearance	:	Grey powder
W/P ratio (by weight)	:	0.14
Fresh Wet Density	:	2250 Kg/m <sup>3</sup>
Compressive Strength	:	15Mpa @ 1 day (ASTMC log-7cm cubes)
	:	25Mpa @ 3 days
	:	35Mpa @ 7 days
	:	40Mpa @ 28 days

(IX) COAL TAR EPOXY COATING:

Aspect	:	Black viscous liquid
Volume solids	:	100%
Mixed Density	:	1.65 Kg/litres
Mixed Viscosity	:	6000 cps @ 250C
Mixed Ratio by weight	:	1:1
Pot Life	:	60 mins @ 250C 30 mins @ 400C
Touch Dry	:	4 hours @ 250C
Final Cure	:	5 days @ 30
C Adhesion (ASTM D4541)	:	2.5Mpa
Abrasion Resistance	:	17 mg/1000 cycles (ASTM D4060)
DFT (2 coats)	:	300 microns

(X) EPOXY COATINGS:

Volume solids	:	100%
Pot Life	:	60 mins @ 250C 30 mins @ 400C
Mixed Density	:	1.55 Kg/litres
Mixed Ratio	:	100 (Base) : 14.4 (Hardner)

Touch Dry	:	4 hours @ 300C
Recoatable	:	12 to 18 hours @ 300C
Final Cure	:	5 days @ 30
CAdhesion Bond (ASTM D4541)	:	1.5Mpa Abrasion
Resistance	:	20 mg CS17 wheel
DFT (2 coats)	:	400 - 500 microns

(XI) PLASTICIZER:

Aspect	:	Free flowing brown
liquid Specific Gravity 250C	:	1.16 + 0.02 @
pH	:	6 + 1
Air entrainment	:	2 + 1
Chloride Ion content	:	0.2%
Surface Absorbtion	:	Reduction by minimum 60%of water BS 1881

(XII) SURFACE RESISTANCE FILM:

Viscosity	:	28 to 34 centipoise
Solid content	:	38 to 42% by weight
Cure time	:	10 hours

Alternate drying & wetting resistance : Yes

UV resistance : Yes

Initially the manufacturer shall provide the results for the above from an independent test house as suggested by the consultant. Infra ray spectrum shall be provided for all such approved samples. Thereafter all chemicals shall be subjected to random testing as specified above at the contractors cost for at least one sample in every 250 units supplied. Unit of supply will be either litres or kilogram.

All chemicals use for rust inhibition bond coat, polymers used for modification, carbonation resistance coats shall be tested by the third party or consultant. The periodicity for various tests shall be the cost of testing and transportation shall be borne by the contractor. All materials shall be required to be labelled properly and batch number of each lot shall be proper. Test certificate for solid content. Viscosity, cure time, shelf life, etc. shall be produced on demand.

(XIII) TESTING PROCEDURE OF AIR ENTERTAINMENT TEST:

A. INSTRUMENTS:

- 1) Hobart Mixture
- 2) Vibrator
- 3) Air Entertainment Meter

B. SPECIFICATION OF AIR ENTERTAINMENT

METER: Model Name : Luftporengchalt

Din 18555/557

Reading : 0% to 100%

Jar capacity : 1 Litre

**6.7 PROCEDURE:**

- Mix water and standard mortar in Hobart mixture mechanically on speed 1 for one minute and on speed 2 for two minutes.
- Wait for 1 minute as waiting period.
- Now compact this mortar in the jar of air Entertainment meter.
- Give 45 second vibrations on vibrator.
- Clear the surface of mortar by trowel.
- Now clear the surface of jar very clean cloth.
- Fix the air Entertainment meter.
- Pass water from one side valve to other side until air bubbles come out.
- Close both the Valves.
- Adjust meter at 0% by correction switch/button.
- Now press test button by thumb in one attempt only.
- Note the reading.

**SPECIFIC GRAVITY TEST:**

- The testing material is carried out at a room temperature.
- Samples are to be filled in a measuring cylinder (500 ml.) upto a mark of 500 ml.
- Hydrometer is introduced and the measuring cylinder is to be filled with testing fluid upto the edge.
- When the hydrometer is brought to a standstill, the specific gravity is read on the graduation scale of the Aerometer.
- It is to be noted that the hydrometer had to float and not be in contact with walls of the cylinder.

- The temperature should be measured and it should remain at the

**MIXING, WORKABILITY AND AIR ENTERTAINMENT TESTS:**

- Use Hobart mixture for mixing
- First place water (required amount) in the bowl and then place mortar in it.
- Start the stopwatch and switch on the mixture.

- Mix mortar on speed 1 for one minute and on speed 2 for one minute.
- Then stop the mixture and wait for a minute.
- Now replace the mortar on mould for flow table.
- The flow table shall be securely bolted to a cast iron or steel plate at least 25 mm thick and 250 mm square.
- Mould shall be centered on the table top and mould shall be wetted and cleansed of all gritty material.
- The table shall then be raised and dropped 15 times.
- Now measure the flow of mortar by scale.
- Replace the mortar in the mould of Air Entertainment metre
- Vibrate it on the vibration table for 45 seconds.
- Now, measure the air entertainment and note the results

**METHOD FOR TEST SOLID CONTENT:**

**SOLID CONTENT:**

This test is carried out in hot air oven. The temperature to be adjusted at 105 deg C:

After two hours, weight the dish. Note the weight. Put the same dish in the oven. After 30 minutes weight it. If the weight is same as step no.4 than the test is complete. If not, than put the dish once again in the oven and after 30 minutes weight it. This procedure is to be out till constant weight is obtained. The result are recorded as in the testing register.

- a) Weight of the empty dish.
- b) Weight of dish and Sample (b.h)
- c) Weight of sample take = b-a
- d) Weight of dish and sample (a-h)
- e) Weight of solids = d-a
- f) Percentage of solids =  $e \times 100/C$

**PROCEDURE FOR TESTING OF SAND**

Only sand which have been tested and found to comply with the requirements of the specification shall be used for mortar.

**TESTING OF SAND:**

The sand shall be tested in accordance with IS 2386 (part I to VIII) to determine cleanliness, sharpness grading and other necessary qualities. No sand shall be used for concrete, which fails with the requirements of these tests.

---

<b>STANDARD</b>	<b>METHOD</b>
<b>STATEMENT</b>	<b>STANDARD</b>
<b>METHOD-1</b>	

**THIS METHOD STATEMENT COVERS THE PREPARATION AND APPLICATION BY HAND, DRY OR SPRAY PROCESS TO RESTORE CONCRETE**

## **WHERE THERE IS NO RESIDUAL CHLORIDE CONTAMINATION**

### **Method Statement:**

Shrinkage compensated, high strength repair mortar reinforced with acrylic fibres.

### **GENERAL:**

- a) The area to be repaired should be marked on the drawings and on the structure and subject to revision based on conditions found as breaking out proceeds.
- b) All further repairs will be at the discretion of the Engineer and subject to re-measurement.
- c) All deviations from the original Bill of Quantities or scope of works must be agreed in writing by the Engineer before reinstatement starts.

### **PREPARATION:**

- a) The edges of all repairs will be cut by angle grinder or similar to produce a regular profile with a minimum depth of 10 mm. No feather edges will be accepted in any repair work.
- b) The predetermined areas shall be broken out to remove all substandard concrete.
- c) Breaking out should be undertaken using high pressure water jetting or pointed mechanical chisels. The use of blunt scabbling hammers which can fracture aggregate, but leave it in place, is not permitted.
- d) Breaking out should continue until sound, dense concrete is encountered.
- e) The substrate should be prepared to a rough surface having at least 5 mm amplitude at 20 mm frequency.
- f) Exposed steel should be cleaned by high pressure water jetting, mechanical wire brush or grit blasting and should be washed down with potable water to remove any residual contaminated dust.
- g) If reinforcement has deteriorated it should be removed and replaced as directed by the Engineer.
- h) The prepared surface must be sound, dense, and free of all oil, grease, loose and fractured aggregate or other contaminants that could impair adhesion.
- i) Thoroughly saturate the surface of the concrete to provide a saturated, surface dry condition. Any standing water on flatwork should be removed prior to application of the mortar.

### **COATING OF STEEL:**

Where directed by the Engineer, the cleaned steel shall be given a continuous coating of CEILCOTE ZR, a single component, active, zinc rich, epoxy primer and allowed to dry for at least 2 hours. If left exposed the CEILCOTE ZR coated steel must be washed with potable water to remove any deposited contamination prior to encapsulation.

### **PRIMING OF CONCRETE:**

Prior to application of the structural repair mortar, the concrete should be wetted out with potable water to give a saturated surface dry condition.

### **TEMPERATURE CONDITIONS:**

- a) EMACO S88 C shall be used when the ambient temperature is between +5°C and 50°C. Chilled water shall be utilized to prevent mixed material temperatures exceeding 32°C.

- b) Substrate temperatures should not be less than 50 C. In hot weather areas to be repaired shall be shaded from direct sunlight.

**MIXING:**

- a) Hand mixing with trowel or similar of structural repair mortar is not permitted. For single bag mixes a variable speed drill with suitable mortar mixing attachment can be used. For multiple bag mixes use a forced action paddle mixer.
- b) Water additional shall be between 3.5 – 4.0 litres of potable water per 25 kgbag.
- c) Pour the required amount of mixing water into the pre-wetted mixing drum. Start the mixer and add the structural repair mortar powder rapidly and continuously. Mix for 3 to 4 minutes after all the powder has been added until the mortar is homogenous and lump free.
- d) Add water, if necessary, within the limits given, until the required consistency is achieved. Mix for a further 1 minute. The amount of water required will be affected by ambient temperature and relative humidity.
- e) Application by spray machine may require lower water addition than the above which will be determined by trials.
- f) For dry process spraying, the structural repair mortar powder shall be mixed with sufficient water to achieve a damp consistency suitable for air conveyance. Additional water, sufficient to achieve full compaction shall be added at the nozzle.

**APPLICATION:**

- a) After mixing, structural repair mortar can either be sprayed or trowel applied. Suitable spraying units are Meyco Deguna 20, Turbosol T20 and Putzmeister P11.
- b) Where structural repair mortar is trowel applied it must be forced into the prepared substrate ensuring intimate contact and good compaction.
- c) Where the hand application of structural repair mortar is to exceed 40 mm in thickness overhead, this must be built up in layers, each not exceeding 40 mm. Each underlying layer shall be heavily cross hatched with a trowel or spatula and allowed to achieve its initial set prior to a subsequent layer being applied in the same manner.
- d) The surface of the placed mortar shall be levelled using a wooden flat. Final finishing may be done with a wooden, plastic or steel trowel, depending upon the finish required.

**CURING**

Good curing is essential. Particular care is required in hot and/or windy conditions. Curing can either be with a single coat of MASTERKURE 181 curing membrane and/or by covering the work with properly secured wet hessian and plastic sheeting.

**STANDARD METHOD-2**

THIS METHOD STATEMENT COVERS PREPARATION AND APPLICATION OF A CAST-IN-PLACE REPAIR. WHERE THERE IS NO RESIDUAL CHLORIDE CONTAMINATION IN THE HOST CONCRETE.

**Method Statement:**

A Shrinkage Compensated, High Strength, Free-Flowing, Micro Concrete, For Cast-In-Place Repairs.

**MICRO CONCRETE:**

The fluid repair medium (micro-concrete) shall be structural repair micro concrete, a

single component, dual expansive, self compacting cement based product to which only the site addition of clean water shall be permitted. The 28 day compressive strength shall be minimum 65N/mm<sup>2</sup> when tested to BS 1881, Part 116. It shall have nil water permeability when tested to DIN 1048 and low chloride permeability when tested to AASHTO 277 (28 days) (<360 coulombs). It shall be produced by an ISO 9000 accredited manufacturer.

**GENERAL:**

- a) The area to be repaired should be marked on the drawings and on the structure and subject to revision based on conditions found as breaking out proceeds.
- b) All further repairs will be at the discretion of the Engineer and subject to re-measurement.
- c) All deviations from the original Bill of Quantities or scope of works must be agreed in writing by the Engineer before reinstatement starts.

**PREPARATION:**

- a) The edge of all repairs shall be cut by angle grinder or similar to produce a regular profile with a minimum depth of 20 mm. No feather edges will be accepted in any repair work.
- b) The predetermined area shall be broken out to remove all substandard concrete.
- c) Breaking out should be undertaken using high pressure water jetting or pointed mechanical chisels. The use of blunt scabbling hammers which can fracture aggregate, but leave it in place, is not permitted.
- d) Breaking out shall continue until sound, dense concrete is encountered.
- e) Exposed steel should be cleaned by high pressure water jetting, mechanical wire brush or grit blasting and be washed down with potable water to remove any residual dust.
- f) The prepared surface must be sound, dense, free of all oil, grease, loose and fractured aggregate or other contaminants that could impair adhesion.

**COATING OF STEEL:**

Where directed by the Engineer, the cleaned steel shall be given a continuous coating of CEILCOTE ZR, a single component, active, zinc rich, epoxy primer and allowed to dry for at least 2 hours. If left exposed the CEILCOTE ZR coated steel must be washed with potable water to remove any deposited contamination prior to encapsulation

**PRIMING/FORMWORK:**

- a) Formwork shall be erected, ensuring it is firmly in place, sealed to be “grout tight” and to provide at least 20 mm cover to steel.
- b) Provision must be made for drainage outlets at the lowest points of the sealed formwork.
- c) A 450 birds mouth shall be constructed at the top of the formwork to ensure ease of placement of the structural repair micro concrete.

**TEMPERATURE CONDITIONS:**

- a) EMACO S66 C shall be used when the ambient temperature is between +5°C and 50°C. Chilled water shall be used to prevent mixed material temperatures exceeding 32°C.
- b) Substrate temperatures should not be less than 5°C. In hot weather areas to be repaired shall be shaded from direct sunlight.

**MIXING:**

- a) The mixer shall be capable of imparting sufficient shear throughout the mix to ensure a homogenous, lump free consistency. Suitable mixers include: slow speed drill with mortar mixing paddle or modified free fall mixers.
- b) Ensure the mixing container is clean and dampened down prior to mixing.
- c) A proportion of the specified amount of water (approx. 90%) to achieve the required flow shall be poured into the mixer. Slowly and the powder whilst the mixing drum is rotating.
- d) Mixing shall be for a minimum of 3 minutes during which time the remaining mix water shall be added, if required, until a uniform free flowing consistency is achieved.

**APPLICATION:**

- a) Ensure all free water is drained from the formwork and the drain holes are plugged before mixing the structural repair micro concrete.
- b) The mixed structural repair micro concrete shall be poured steadily and continuously, through the birds mouth opening at the top of the formwork. A slow steady pouring rate reduces the chances of air entrapment.
- c) Alternatively, the structural repair micro concrete shall be placed by pouring into a funnel attached to a flexible pipe of 30 – 50 mm diameter. The pipe should initially be placed near the bottom of the formwork and raised as the pour continues.
- d) For large scale repairs of extended length, the structural repair micro concrete shall be placed in layers, i.e. place from left to right in one layer and repeated with successive layers applying the structural repair micro concrete wet on wet.
- e) Structural repair micro concrete shall be placed continuously, minimizing the amount of time between successive batches.
- f) Structural repair micro concrete is self compacting and does not require external vibration. Tapping the formwork lightly with a hammer during placement will contribute towards effective consolidation of the material.

**CURING:**

- a) Using the appropriate MASTERKURE curing compound, surfaces shall be sprayed immediately upon removal of formwork, extending at least 10 cm onto the adjacent concrete around the periphery of the repair.
- b) Protect from wind, rain and direct sunlight for 24 hours.

**TECHNICAL SPECIFICATIONS**

**GENERAL - REMOVAL OF COVER:**

- a) Repair and rehabilitation works does not mean plaster, paint and forget. Contractors are advised to treat this part of tender/Contract with an understanding that is required for new works. It is evitable that the work when carried out by the contractor is done with full knowledge of the material used, its high points and its shortcomings. Every additive used should be properly dealt with and prior approval about the methodology of repair and mixing proportion be ascertained by the contractor from the consultants.
- b) Preparation for any work forms an important part of repairs and rehabilitation work and due importance given to all surface preparations. Approval and consultants permission to go ahead is required whenever such surface preparations are completed and mandatory before actual repairs can start. Improper preparation can lead to future failures.
- c) All repairs to structural members must be preceded with a proper support system. All live loads shall be either removed or dismantled and proper care shall be taken that the structure is not loaded during the entire duration of repairs. The structural support system must be

worked out for each structural member. Structural significance and safety of the whole structure is of paramount importance. Necessary suitable propping is required to be provided to ensure release of loads on the treated member. It is mandatory for the contractor to seek consultant's approval of the support system. The ultimate responsibility of the support system rests with the contractor. The gist of the point being the paramount importance of the safety of the structure under repair.

- d) The contractor is advised to appoint on full time basis an experienced site Supervisor/Engineer to co-ordinate with the consultant and supervise the works.
- e) All ratios pertain to 43 grade cement. In case the contractor wishes to change the grade of cement to be used from 43 to 53 then the percent increase in the sand shall be not more than 15 percent and in no case the quantum of cement shall be less than 0.20 cum per cum of mortar.

#### **REMOVAL OF CONCRETE COVER:**

- a) The range of removal of cover shall extend to the limit of crack/hollowness/corrosion of rebar. The governing dimensions of removal shall be based on the minimum dimensions shall extend beyond the zone of rusting to a minimum dimension as specified in the drawing.
- b) Concrete surfaces to which treatment are to be applied shall be freshly exposed parent concrete free of loose and unsound materials. Prepare surfaces by mechanical abrasion or by chisel and hammer unless prohibited by environmental limitations in which case acid etching may be used.
- c) A good base or foundation shall be prepared for successful application of any treatment.
- d) All unsound/weak concrete material shall be first removed by the contractor upto the required depth as directed by engineer. Chipping shall continue until there are no offsets in the cavity, which will cause an abrupt change in the thickness of repaired surface. No square shoulders shall be left at the perimeter of the cavity, all edges shall be tapered. The final cut surface shall be critically examined to make sure that it is sound and properly shaped. In case of this project the entire cover has to be removed. The contractor shall endeavour to remove the cover of the entire under surface of the jetty including inverted beams, cross head beams and concrete blocks.

#### **CLEANING OF CONCRETE SURFACE:**

- a. Concrete surface to which treatments are to be applied shall be freshly exposed, parent concrete free of loose and unsound materials. Prepare surfaces by mechanical abrasion or chisel and hammer unless prohibited by environmental limitations in which case acid etching may be used.
- b. MECHANICAL ABRASION: Use sandblasting or scarifying or wire brushing chisel and hammer or other approved means. The purpose of this is to achieve a surface that is clean and dust free. Distressed loose concrete is to be removed.
- c. ACID ETCHING: Each surface with a commercial grade (22 deg Baume) of hydrochloric acid diluted at a ratio of 10:90 to 20:80. After this application, scrub surface with a stiff bristled broom, brush, or similar implement. Immediately after foaming action of acid has subsided, flush surface with water jets until all residues are removed. Repeat procedure until laitance is completely removed wash such areas with water at least three times and allow to air dry prior to further treatment.

#### **RUST REMOVAL:**

- a. All scales and rust oxides formed on the steel rebars is to be removed and the rebar surface made free from all deleterious material.
- b. MECHANICAL ABRASION: Use sandblasting or scarifying or wire brushing or chisel and hammer or other approved means. The purpose of this is to achieve a surface that is clean dust free. Use of chisel and hammer can also be used with a fair degree of success to remove rust and corroded particles that stick to the surface of the rebar.
- c. ACID ETCHING: Refer detailed specification given in above Technical Specifications.

#### **REMOVAL OF REBARS:**

- a) Where the corrosion has been more than 60% to 70% and the sectional area has reduced by more than 60 percent, it is desirable to remove the rebar as the effect of corrosion has set into the steel totally.
- b) Removal of rebar has to be restricted to the minimum possible extent and the removal should be effected by use of handsaw and the cut should be beyond the corrosion zone. Use of hammer and chisel should be avoided to remove/cut the rebar. This induces unwanted end stresses.
- c) Addition of rebars has to be as per specification detail given in above Technical Specifications as the case may be. Only MS rounds shall be used wherever MS rounds exist and for steel to be used wherever for steel exists.
- d) Additional reinforcement bars are to be provided wherever the corrosion has etched the rebar to more than specified degree and wherever so specified and directed by the consultant. **WATER CLEANING:**
  - a) All surfaces so prepared as per above Technical Specifications, have to be cleaned of all the effects of the above procedure.
  - b) A fresh water jet is recommended for the cleaning process. This is aimed to remove all dust, oil, rust particles and any such deleterious material that is not conducive to sound construction practices. The jet pressure can also be achieved by a stream of fast flowing water from a pipe. Usage of sea water is not permitted for this purpose.
  - c) Inspection of concrete surface prior to mortar application.
  - d) Inspect all concrete surfaces prior to application of mortar to ensure that requirements of this Article are met.
  - e) Surfaces shall be free of any deleterious material such as laitance, curing compounds, dust, dirt and oil. Materials resulting from surface preparation specified shall be removed.
  - f) All concrete surfaces shall be dry as defined below unless a water insensitive coating is used. Surface temperature shall be at least 40 F to permit wetting of concrete surface by polymer coating.
  - g) Evaluate moisture content for concrete by determining if moisture will collect at boundary lines between old concrete and new coating before the new coat has cured. This may be accomplished by tapping a 4 x ft. polyethylene sheet to concrete surface. If moisture collects on underside of polyethylene sheet before polymer would cure, then allow concrete to dry sufficiently to prevent the possibility of moisture between old concrete and new layer. **ETCHING/ACID WASHING:**
    - a) **ACID ETCHING:** Etch surface with a commercial grade (22 deg Baume) of hydrochloric acid diluted at a ratio of 10:90 to 20:80. After this application, scrub surface with a stiff bristled broom, brush or similar implement. Immediately after foaming action of acid has subsided, flush surface with water jets until all residue is removed. Repeat procedure until laitance is completely removed wash such areas with water at least three times to air dry prior to further treatment.
    - b) This can be used for both concrete surfaces or steel surfaces. The effecting of etching has to be removed by use of liberal water spraying. Water cleaning is an essential part of this treatment and wherever not so specified water cleaning is to be operated.

**ANTI CORROSIVE TREATMENT (RUST INHIBITOR COAT)  
FOR REINFORCEMENT**

**GENERAL:**

Submittals:

The contractor shall submit manufacturer's certification verifying conformance to material specification as specified hereunder.

**LABELING:**

Contractor shall clearly mark all containers with following information

- 1) Name of Manufacturer

- 2) Manufacturer's produce identification
- 3) Manufacturer's instruction for mixing
- 4) Warning for handling and toxicity
- 5) Solid content of the polymer.

**APPLICATION CONTROL:**

The contractor shall submit mixing and application procedures for approval prior to use.

**PRODUCT DELIVERY, STORAGE AND HANDLING :**

**DELIVERY MATERIALS:**

Contractor shall deliver all materials in sealed containers with labels legible and intact.

**STORAGE MATERIALS:** Contractor shall arrange to store all materials at temperature between 5 C and 38 C unless otherwise recommended by manufacturer.

**HANDLING OF MATERIALS:** All materials shall be handled in a safe manner and in a safe manner and in a way to avoid breaking container seals.

**PROJECT CONDITIONS:**

**ENVIRONMENT REQUIREMENTS:** Contractor shall comply with manufacturer's recommendations as to environmental conditions under which the bonding compound may be applied.

**PRODUCTS:**

ROFF/MC BAUCHEMIE, PRODUCTS NAMELY :

MC – Bauchemie shall be used in the following ratio:

Collusal 25 to be added to water in the ratio of 1:6 parts by weight to which collusal MK is added until applicable slurry is formed. General recommended usage.

Collusal MK	approx. 100 grams
Collusal 25	approx. 15 grams.
Water	approx. 90 grams

**THIS MIX SHALL HAVE THE FOLLOWING PROPERTIES:**

These specific quality requirements are stipulated for a common work of passivation needs in restoration. All the test facilities are generally not available even in sophisticated laboratories in the country. Few manufacturers do have such an in-house facility with them. The difficulty therefore lies in strict stipulations and their subsequent job site compliance. Therefore reliability of the product quality is important.

**EXECUTION:**

**PREPARATION OF STEEL SURFACE:**

Steel surfaces to which chemicals are to be applied shall be exposed, this parent steel should be free of loose and unsound rusted materials. Surfaces shall be prepared by mechanical abrasion using sand blasting/stiff wire brushing as instructed by Engineer.

### **INSPECTION OF STEEL SURFACE PRIOR TO APPLICATION:**

All steel surfaces prior to applications of adhesive shall be thoroughly inspected and got approved by the contractor.

Surfaces shall be free from any deleterious materials, such as oil, dust, rust, etc.

### **CHEMICAL MIXES:**

Chemical components shall be mixed in a clean container free from harmful residue or foreign particles.

POLYMER Components shall be thoroughly blended with a mechanical mixer to an uniform and homogenous mixture. Small batches (upto 1 litre) however shall be allowed by manual mixing such as using spatulas, palette knives, etc. All liquids shall be first mixed and then added to solids.

### **CHEMICAL APPLICATION:**

- Work of application of bonding adhesive and concrete placements shall not be allowed to be performed beyond 40 deg. C atmospheric temperatures and below t deg. C.
- Chemicals shall be applied to concrete surfaces by spare equipment. However, contractor may apply the adhesives by brush, subject to the permission of engineer.
- Fresh plastic concrete shall be applied to while adhesive is still tacky. Generally, 6 hours of waiting time is suggested. If POLYMER adhesive cures to extent of losing its tacks before lastic concrete is placed, the same shall be slightly abraded and shall reapplied prior to application of other layers or modified mortars.

### **CLEAN UP**

Concrete surfaces shall be well protected beyond limits of surface receiving adhesives against spillage and over spraying.

### **SAFETY**

Contractor shall advice all workers working with bonding chemicals to avoid contact with eyes and skin inhalation of vapours and ingestion. Necessary protective and safety equipment's in the form of hand gloves, welders, goggles, shall be provided by the contractor on site.

### **ADDITION OF STEEL REBARS (MAIN):**

Additional Steel as may be required shall be provided as per the direction of the Engineer-in- charge. At all places where the steel cross section is reduced beyond 30% of its original cross section addition steel shall be provided. The provided steel shall be in accordance with the rebars present in the section. The diameter of the rebars to be provided shall be equal to or greater then the rebars present and in no case shall be less then the diameter of the rebars present. If the old rebars as MS addition should be of MS only & in case of old rebars being for addition should be for steel.

The lap to be provided shall be as per relevant section of IS 456 and shall always be provided at both the ends. Lap joinery shall be effected by use of GI wire, which is

corrosion free. Welded connections can be used if the rebar to be replaced is of good quality and is still free from corrosion. If the rebars in the section have corrosion affected steel then it is essential to replace the rebar with a rebar of equal diameter or a higher diameter. The minimum diameter of the rebars so used shall be at least 12 mm. If the corrosion is spread out and the extent of corrosion is more than 50 percent of the length the entire length of the rebar is to be replaced. Welding if adopted shall be as per relevant section of IS 456 and shall be adopted on both the ends. Corresponding reduction in lap lengths can be incorporated thereof.

**ADDITION OF REBAR (TRANSVERSE):**

Criterion for provision of rebars in the rings or links section shall same as per TS 7./ Rings/Links to be replaced in totality needs no further clarifications. Rings or links that are to be replaced partially will be provided in a minimum shapes of a U or C and the lap provisions shall be fully followed. The minimum diameter of the rebar to be used in rings shall be 6 mm and above. Proper joining shall be achieved by using GI wire, which is corrosion free. If the old rebars are MS additions should be of MS only & in case of old rebars being for additions should be for steel.

Relevant provisions of IS 456 shall be followed and in no circumstances shall be provision be violated. **BOND COAT:**

**GENERAL: SUBMITTALS:**

The contractor shall submit manufacturer's certification's verifying conformance to material specifications as specified hereunder.

**LABELING:**

Contractor shall clearly mark all containers with following information.

- 1) Name of Manufacturer
- 2) Manufacturer's product identification
- 3) Manufacturer's instruction for mixing
- 4) Warning for handling and toxicity
- 5) Solid content of the polymer

**APPLICATION CONTROL:** The contractor shall submit mixing and application procedures for approval prior to use.

**PRODUCT DELIVERY, STORAGE AND HANDLING:**

- **DELIVERY MATERIALS:** Contractor shall deliver all materials in sealed containers with labels legible and intact.
- **STORAGE MATERIALS:** Contractor shall arrange to store all materials at temperatures between 5 C and 38 C unless otherwise recommended by manufacturer.
- **HANDLING OF MATERIALS:** All materials shall be handled in a safe manner and in away to avoid breaking container seals.

**PROJECT CONDITIONS:**

**ENVIRONMENT REQUIREMENTS:** Contractor shall comply with manufacturer's

recommendations as to environmental conditions under which the bonding compound may be applied.

**PRODUCTS:**

ROFFE/MC Bauchemie product namely: MC Bauchemie shall be used in the following ratio:

Nafufill BB2 be added to water in the ratio of 1:3 parts by weight to which Zentrifix HB is added until applicable slurry is formed. General recommended usage for One square meter is.

Zentrifix HB	approx 1.2 to 1.5 kg
Nafufill BB2	approx. 90 grms.
Water	approxd 2.7 kg

Bonding Adhesive shall have the following properties:

These specific quality requirements are stipulated for a common work of bonding needs in restoration. All the test facilities are generally not available even in sophisticated laboratories in the country. Few manufacturers do have such an inhouse facility with them. The difficulty,

therefore, lies in strict stipulations and their subsequent jobsite compliance. Therefore reliability of the product quality is important.

**EXECUTION:**

**PREPARATION OF CONCRETE SURFACE:**

Concrete surfaces to which bonding chemicals are to be applied shall be exposed, this parent concreted should be free of loose and unsound materials. Surfaces shall be prepared by mechanical abrasion using blasting/stiff wire brushing as instructed by Engineer. Refer to Technical Specifications for details.

**INSPECTION OF CONCRETE SURFACE PRIOR TO ADHESIVE APPLICATION**

All concrete surfaces prior to applications of adhesive shall be thoroughly inspected and got approved by the contractor.

Surfaces shall be free from any deleterious materials, such as oil, dust, dirt, etc.

**ADHESIVE MIXES:**

Bonding components shall be mixed in a clean container free from harmful residue or foreign particles.

POLYMER Components shall be thoroughly blended with a mechanical mixer to a uniform and homogeneous mixture. Small batches (upto 1 litre) however shall be allowed by manual mixing such as using spatulas, palette knives etc. All liquids shall be first mixed and then added to solids.

**ADHESIVE APPLICATION AND CONCRETE/SHOTCRETE /**

### **MORTAR PLACEMENT:**

- Work of application of bonding adhesive and concrete placements shall not be allowed to be performed beyond 40 deg. C. atmospheric temperatures and below 5 deg. C.
- Bond adhesive shall be applied to concrete surfaces by spray equipment. However, contractor may apply the adhesive by brush, subject to the permission of Engineer.
- Fresh plastic concrete shall be applied to while adhesive is still tacky. Generally, 6 hours of waiting time is suggested. If POLYMER adhesive cures to extent of losing its tracks before plastic concrete is placed, the same shall be slightly abraded and shall be wetted with water sprinkling prior to application of modified mortars.
- Freshly placed plastic concrete shall be thoroughly consolidated to ensure full bonding of new concrete.

### **CLEAN UP:**

All concrete surfaces shall be well protected beyond limits of surfaces receiving adhesives against spillage and over spraying.

### **SAFETY:**

Contractor shall advise all workers working with bonding chemicals to avoid contact with eyes and skin, inhalation of vapours and ingestion. Necessary protective and safety equipments in the form of hand gloves, welders, goggles, shall be provided by the contractor on site.

Field quality performance requirement.

- The Engineer shall evaluate bonding of fresh concrete/shotcrete/mortar to existing concrete after fresh material has cured for not less than 7 days.
- The evaluation shall be performed by sounding, tapping fresh concrete with a blunt metal instrument.
- Detection of a hollow sound in any area shall be reason to suspect inadequate bonding. Under such circumstances the contractor shall on instructions of Engineer, core each such area after 28 days concrete/shotcreting for further determination of bonding adequacy.
- Coring shall be thorough new concrete/shotcrete/mortar and into the existing concrete, core diameter shall be as required by the Engineer. Length of cores shall be twice the core diameter or twice the thickness of new concrete/shotcrete/mortar, or as instructed by Engineer. This is essential only in case the section is treated for stress related causes. No tests are suggested for cover replacement.
- Cores will be visually inspected Engineer evidence of poor workmanship and shall be tested in tension by the contractor to evaluate the quality of bond between new concrete/shotcrete/mortar shall be deemed to be satisfactory. Failure at the bondline shall be concluded as lack of proper bond between the new concrete/shotcrete/mortar and host concrete and the contractor shall dismantle such areas of work as instructed by Engineer and prepare the surface after chipping off new concrete/mortar work and abrading the bonding interface. Applicable only in patches form the existing layer.

### **REMOVAL OF EXISTING WATER PROOFING LAYER:**

All existing waterproofing layer will be removed by the contractor, wing wise using chisel & hammer. The hammer will not be used directly on the slab, chisel is to be used only in the slanting manner to ensure that the chisel does not enter the slab section. Any damage to the slab will be made good using proper shuttering, steel and concrete mix 1:1 ½ :3. It shall be allow cure for 7 days before further work is undertaken.

### **PRE TREATMENT :**

- After the slab top face is exposed the same shall be first broom cleaned and then watercleaned immediately on cleaning with water a cement slurry with standard waterproof compound based on latex polymer Dichtament D.S. (mc-Bauchemie) is to be filled in to crevices, cracks and unevenness is properly treated. The proportion shall be as directed by Engineer.
- Applying cement slurry over entire surface inclusive of wafts as per instruction of GI and curing for 24 hours is to be carried out to check if any leakage occurs. In case of any leakages, same have to be treated with cement slurry with latex based polymer compound.

### **WATERPROOF TREATMENT:**

Brickbats of varying sizes will be laid in 25 mm to 30 mm thick cement mortar pad 1:4 in all positions with an average thickness of 125 mm in proper slope not less than 1" in 7 feet. This layer has to be cured for 3 days. After curing a layer of 40mm of Indian patent stone 1:3 is to be laid complete with curing making square of 0.5 feet. Waterproofing compound of standard make to be added in both layers. China mosaic chips shall then be fixed later on.

### **POLYMER MODIFIED MORTAR:**

#### **PRODUCTS:**

- All components used for polymer repair system are to be from one of the approved makes of polymers. All components are to be of the same make. No components of different makes can be used in conjunction with each other.
- The products shall only be from the approved list of companies.
- Proper care is to be taken when using the material to maintain the required consistency and purity.
- Only polymer based on Acrylics Nofufill BB2 of M.C. Bauchemie, can be used. The latex should have solid to a maximum of 45% of 25. All products prior to application and use should be the consultant's approval and the mix design for various brand shall be as suggested by the consultant.

#### **MORTAR MIXES :**

- Mix polymer components in clean container free of harmful residue of foreign particles.
- Temperature from preparation of polymer mortar to application should be between 60F – 100 F, otherwise recommended by manufacturer.
- Thoroughly blend polymer with a mechanical mixer to uniform and homogeneous mixture if the polymer is more than one month old.
- The proportion of mixing the polymer for modification shall be decided by the use of the modified mortar. For use in cover replacement the percent of polymer can be limited to 7 percent and for use in core replacement 10 percent.

#### **MORTAR APPLICATION:**

- Apply polymer mortar to concrete surface by trowel or screed. Thickness shall be within the limits recommended by the manufacturer.
- Work mortar into place and consolidate thoroughly so that all concrete surfaces are wet by the mortar and entrained air is reduced to the level recommended by manufacturer.
- Finish surface of mortar to texture, colour and smoothness required for the specific application.
- Upon completion of finishing operations, allow mortar to cure in accordance with normal curing practices.

## **CLEANUP:**

Protect concrete surfaces, beyond limits of surface receiving mortar, against spillage.

## **SAFETY:**

Polymer materials may be skin irritants or sensitizers to many people. Accordingly, advise applicators to avoid contact with eyes and skin, inhalation of vapours and ingestion. Make protective and safety equipment available on site. Heed all level warnings by manufacturer. Make application in accordance with applicable safety laws.

## **System Methodology**

- Repair system for severely deteriorious concrete will consists of the following components.
- Rust Inhibitors Coat (RIC)/Corrosion preventive coating (CPC). Spraying of RIC/CPC on reinforcement bars (new and old), covering max, area of cleaned reinforcement bars.
- Application of bond coat. (Polymer with cement slurry). Appropriate polymer specifically to be used for bonding is to be applied to all surfaces as cleaned and prepared as per module. A stated above. The surface coat is to be uniform and evenly spread. Under no circumstances shall this coat be left uncovered for more than 30 minutes. In case of the next layer not being applied within this specified time limit then additional coat of bonding agent is to be applied.
- Applications of polymer modified mortar over deteriorate portion. The mortar prepared for use shall per minimum 1:3 in case of 43 grade cement and can be 1:4 in case of 53 grade cement. The polymer to be added should be at the rate of 6.5 kgs/bags of cement. The ratio is to be in conformity.

## **GROUTING FOR DISTRESSED CONCRETE:**

### **PRODUCTS:**

- All components used for grouting repair system are to be from one of the approved makes of polymers. All components are to be of the same make. No components of different makes can be used in conjunction with each other. Only be MC Bauchemie product shall be used.
- The product shall only be from the approved list of companies.
- Proper care is to be taken when using the material to maintain the required consistency and purity.
- Only polymer latexes based on Styrene butadiene (SBR), acrylics, polyvinyl acetate orepxoxies can be used. The latex should have solid to a maximum of 50% and minimum of 40%. The physical chemical and structural properties of the material used are to be submitted and specific approval to be seek for the material/system, to be used.

### **SURFACE INSPECTION AND PREPARATION:**

- All surfaces to be treated are to be exposed to the base level with removal of all claddings, plasters, facaders, waterproof layers etc. The surface is to be examined for surface cracks, crevices and spalls and honey combing.
- Concrete surface to which treatment is to be applied shall be freshly exposed parent concrete free of loose and unsound materials. Prepare surfaces by mechanical abrasion unless

prohibited by environmental limitations in which case acid etching may be used.

- Mechanical abrasion – Use sandblasting or scarifying or water blasting or other approved means.
- **ACID ETCHING** - Etch surface with a commercial grade (22 deg. Baume) of hydrochloric acid diluted at a ratio of 10:90 to 20:80. After this application, scrub surface with a stiff bristled broom, or similar implement. Immediately after foaming action of acid has subsided, flush surface with water jets until all residue is removed. Repeat procedure until laitance is completely removed. Wash such areas with water at least three times and allow to air dry prior to further treatment. This method of cleaning is to be used only in exceptional cases and under normal cases permission will not be given for use of this method.
- Inspection of concrete surfaces prior to mortar application.
- Inspect all concrete surfaces prior to application of mortar to ensure that requirements of this Article are met.
- Surfaces shall be free of any deleterious materials such as laitance, curing compounds, dust, dirt and oil. Materials resulting, from surface preparation specified shall be removed.
- All concrete surfaces shall be dry unless a water insensitive coating is used. Surface temperature shall be at least 40F to permit wetting of concrete surface by polymer coating.
- Evaluate moisture content for concrete by determining if moisture will collect at surfaces. This may be accomplished by taping a 4 x 4ft polyethylene sheet of concrete surface. If moisture collects on underside of polyethylene sheet before polymer would cure, then all concrete to dry sufficiently. Drying of the surfaces can be accomplished by either heating the surfaces by blow lamps or by use of sawdust, sand or any other means so that the surface is bone-dry. **IDENTIFICATION OF METHOD OF GROUTING: For All Surfaces Having Cracks/Crevices:**
- Locate the cracks by either surface inspection or by scrubbing the surface. In case the cracks are not visible to naked eye use compressed air to clear marks. Having identified the cracks use light chisel or mechanical/electrical saw to clear the crack upto the depth of the crack. In case widening of the crack is necessary to reach the depth of the crack it is advisable to do so at this juncture.
- After cleaning/widening the crack use compressed air/water jet to clean the opened crack surface. Ensure that the surface is dried in case water jet is used.
- A method of grouting through rows of grout nipple is to be adopted for all such cases. **GROUTING FOR HONEY COMBED SURFACES:**
- For surface, which exhibits honeycombed concrete, the surface has to be maintained in its dry state and a method of grouting through triangular grout nipples is to be adopted.
- The opposite side to the grouting surface has to be sealed for flowing grout by either impervious cement plaster or by use of proper sealant as specified in the material to be used for grouting. **SIZE AND SPACING OF NIPPLES:**
- To determine the size of nipples use a standard caliper or a metric scale and measure the width of the opened crack. The size of the nipple to be fixed within the crack has got to be minimum half the surface width of the crack measured above, but should not exceed 15 mm in dia.
- The nipples to be used should be of metal with one end tapered and thickness should be

sufficient to withstand 5 m head of water. The spacing for the crack depends inversely to the width of the crack and will not exceed more than 300 mm c/c and will not be less than 125 mm c/c. The member of nipples along the crack will always be a less than two rows of nipple that needs to be fixed parallel to the crack at the same distance as the nipples spacing in the crack so as to form equilateral triangle with the apexes in the crack.

#### **EFFLORESCENCE & FLAKING:**

Efflorescence is removed by rubbing brushes on the damaged surface. A Solution of one part of hydrochloric acid or sulphuric acid and five parts of clean water is prepared and it is applied with the help of brushes on the affected area. The surface is then washed clean water. Water should not be used to wash the surface so as to remove efflorescence. In that case should salts will be partly carried inside the surface and efflorescence will reappear again. It is advisable to postpone painting till efflorescence ceases. For this purpose, the deposit is brushed off from the surface as it appears and the surface is kept under observation for a further period of few days. If efflorescence appear again, it is removed with dry brush and the process is repeated till all the soluble salts are removed under the condition of normal drying.

#### **CRACKS IN KITCHEN/TOILET/BATHROOM TILES AND OR SANITARY FIXTURES:**

Surface preparation includes cleaning of the crack and preparation of a proper groove along the length of the crack. This can be done either with a chisel and hammer application or by using a groover. Cleaning of the crack is done to ensure that the entire depth of the crack to be treated is properly cleaned and exposed. The cracks be cleaned properly using a wire brush and then a solution of sodium silicate be liberally applied to seal the crack. Thereafter a paste of 3 parts of white cement, 1 part of aquaproof (waterproofing chemical) and water should be applied and again sodium silicate applied to it as the paste dries. The same crack can also be treated by using a non-shrink chemically modified cement mortar.

#### **CRACKS AROUND WINDOWS/DOOR FRAMES:**

The approximate location of holdfast is the point where the crack are the maximum and are found to converge remove all loose plaster, expose the holdfast, if rusted removed all rust layer apply rustolene or any standard rust preventive solution and allow to dry. Reconstruct the portion removed earlier to original, size, shape and texture using cement, sand, mortar as filling material cure using proper curing methods for 5-8 days.

#### **DISMANTLED MATERIAL GOVT. PROPERTY:**

The contractor shall treat all materials obtained during dismantling of a structure, excavation of the site for a work, etc. as Government's/Nigam/ULB property and such materials shall be disposed off to the best advantage of Government/Nigam/ULB according to the instructions in writing issued by the Engineer-in-Charge.

## **SPEIFICATIONS FOR E&M WORKS**

### **Technical Specification of Works :**

#### **1. CONTRACT INCLUDES:**

- 1.1 Supply & erection of all required tools plants (T&P) for drilling of necessary Tube well bore of required size as detailed in schedule "G", lowering of well tubes together with all excavation, pumping, all temporary masonry work, channels for samples, dressing & cleaning of site & reinstatement.
- 1.2 Supply & erection of all required T& P for development of Tube Well.
- 1.3 Supply & erection of all temporary and auxiliary plants such as derricks, hoists, etc. and other appliance required for the work.
- 1.4 Supply of all lubricants and oils, cotton and other material required during the drilling, developing and testing operations.
- 1.5 Supply of bentonite and sticky clay, if required to line up the bore and also sodium hexameta phosphate required to dislodge the sticky mud during the development of the bore.

#### **2. TRANSPORTATION:**

This includes transportation of drilling and developing equipment like rig, compressor, O.P. unit with all required auxiliary T&P and material to proposed site including carting loading, unloading etc. complete work.

#### **3. DRILLING:**

- 3.1 This includes installation of rig machine, drilling of bore well, up to required depth for successful construction of tube well to the satisfaction of Engineer incharge, including supply of all required material like bentonite, sticky clay and Ferrospeed electro/ ISI mark etc. and also, provision for water arrangement for drilling at their own expenses.

#### **4. LOGGING:**

- 4.1 After completing the bore well, its logging will be within the scope of the contractor which shall be done by the departmental/U.P. Jal Nigam approved loggers on their own cost.
- 4.2 No compensation shall be paid to the contractor on account of any delay in electric logging of bore well.
- 4.3 The Contractor shall maintain the bore hole up to logging or lowering with shrouding is complete in all respect.
- 4.4 Depth of the bore well shall be measured while logger testing as per the reading recorded on logger machine or sounding measured prior to the lowering of the tube well assembly whichever, is deemed acceptable.
- 4.5 If the bore well collapse due to whatsoever the reason or phenomenon in course of bore well work. No payment shall be made to the contractor. It is the sole responsibility of the contractor to secure the borewell done successfully.

## 5. TUBE WELL ASSEMBLY AND ITS LOWERING:

5.1 **MSERW Housing pipes of 300 mm dia and minimum 7.1 mm thick and Casing/Slotted pipes of 200 mm dia size minimum 7.1 mm thick as mentioned in detailed specification IS 4270 : 2001 of tube well Assembly , all required accessories related shall be supplied by contractor.**

5.2 Before lowering of Tubewell assembly, Contractor must ensure duly cleaning and double coat painting of MSERW Housing as well as casing/slotted pipes at its own.

5.3 **Carting or Transportation charges of MSERW Housing & Casing/Slotted pipes from contractor Store**

to the pin point of tubewells shall be borne by Contractor at its own along with all labour, loading & unloading charges with road taxes & tolls as well etc. complete.

5.3 The contractor shall prepare the tube well assembly as approved by the Engineer in advance and shall arrange the same in proper sequence at site. He shall get the same checked and passed by the Engineer or his authorized representative. There after the assembly shall be painted with standard quality anti-corrosive paint.

5.4 Before lowering the tube well assembly the contractor shall ensure that the bore hole is cleared up to the required depth and shall get it checked while logger testing or before the lowering of the tube well assembly by the Engineer or his authorized representative.

5.5 The lowering of tube well assembly shall be carried out by the contractor with all materials required for proper completion of the work.

5.6 The quality of the welding Job work of jointing the tube well assembly parts should be enough to stand the entire weight of the assembly while hanging. Lowering shall be carried out in the presence of the Engineer or his authorized representative. The contractor shall ensure that lowering of assembly takes place smoothly. It will be the binding upon the contractor to bear the sole responsibility of successful lowering done.

5.7 The contractor shall take the sounding of the lowered tube well assembly to the Engineer or his authorized representative as and when lowering is complete. In case the complete sounding of tube well assembly is not found, it will be entire responsibility of the contractor to restore the sounding or revive the sounding at their own.

## 6. PEA GRAVEL AND ITS SHROUNTING :

6.1 The gravel packing shall be done by a suitable method approved by the Engineer or his authorized representative.

6.2 The packing of gravel in the annular space between the well pipe and the bore shall start at the bottom of the well and terminate until the ground level.

## 7.0 DEVELOPMENT:

7.1 The development of the tube well shall be done first by the proper size & capacity air Compressor preferably 600 PSI which shall be followed by O.P. Unit of **03 cusec** capacity as per relevant I.S. and code of practice running with the U.P. Jal Nigam.

- 7.2** Assumption of successful completion of development by compressor should have the following indicators:
- (i) Gravel should not shrink even after the blow back of air compressor as per relevant standard while concentering each stratum.
  - (ii) Range of permissible PPM in between 3000 to 4000 ppm while starting and 100-200 ppm later on while running.
  - (iii) Bore well should soak water freely and continuously. Failing which, bridging phenomenon shall be treated as running with the bore well and development of the tubewell by compressor shall have to be carried out a fresh until the bridging phenomenon is somehow, removed/ eliminated.
- 7.3** The development of the tube well by O.P. Unit shall be done by 03 cusec VT type O.P. Unit until the water level and discharge becomes steady and sand free within five minutes which is subjected to starting less than 100 ppm.
- 7.4** Discharge shall be selected at 60% of the water discharge quantity free from sand within 20 minutes.

**7.5** Yield of the Tube well is required as per depth of strata length taped and recommendation 60% discharge of the yield conforming to relevant IS. Failing which, construction of tube well shall be considered to have done workmanship / quality of work not conforming to relevant IS, and deduction shall be made pro-rata in terms of discharge.

**8. LIMITS OF CONTRACT:**

The work included in this contract shall be deemed to be completed finally when all the specifications laid down herein and conditions of contract attached have been completed and tube well having been successfully tested and handed over to the ULB.

**9. DESIGN, MATERIAL AND WORKMANSHIP:**

The specification as laid down in tender document for the execution of the various parts are to be followed. Any suggestions with a view to effect the economy or to increase reliability in operation which the tenderer may wish to offer must be set forth in the schedule as addendum for consideration.

**10.0 RESPONSIBILITIES OF CONTRACTOR:**

- 10.1** The contractor shall maintain Chaukidar at his own cost to watch T&P and also provide materials for protection of work if necessary. He shall arrange for storing of T&P and materials for accommodation of supervising staff engaged on the work by him. The contractor shall also arrange his own supplies of water, fuel etc. for the use of his workman and also for the execution of the work.
- 10.2** Until the test specified herein have been applied and the installation have been passed and formally accepted by the Engineer the contractor shall be entirely responsible for the working or performance, whether such working as for the propose of testing or in the service of Nigam.
- 10.3** As each part of the construction of the tube well is completed, it shall be checked over by the Engineer or his authorized representative. The representative of contractor shall ascertain with the Engineer's representative from time to time, what parts he wished to check over and pass but such passing shall be no way relieve the contractor from his responsibility, until the entire work has been completed according to the contract and taken over by the Engineer.

- 10.4** Contractor shall take all safety measures at site. He shall arrange first aid box at site. in the event of any accident, he should make arrangement for primary & higher medical facilities to labour engage by him. Jal Nigam shall not bear any liability about accident at site. The entire liabilities about first aid, higher medical facilities and compensation if arises have to be borne by the contractor.
- 10.5** The contractor shall submit daily report of the work done by him each day to the Engineer on the prescribed format to be obtained from the Engineer. These reports shall be handed over to the Engineer's representative stationed at site or/also posted to the Engineer (in case there is no representative stationed at site) every day after close of the day. Postage charges for the same shall be borne by the contractor.
- 10.6** Work done of any kind to the designated site for the construction of Tube Well or any other material such as fuel etc consumed by the contractor shall not be paid out in case of failure of tube well however contractor can retrieve them.

#### **11. TESTS:**

During the progress of the work and after its completion the contractor shall carry out such tests, as in the opinion of the Engineer are necessary to ensure that the installation compile with the conditions of these specification whether under test conditions or in ordinary working.

All pipe connections and other apparatus required for the tests shall be provided by the contractor at his own cost.

#### **12. REINSTATEMENT:**

After completion of work the contractor shall remove all surplus material and dresses the ground disturbed during the operation of the excavation boring and construction of the well to the satisfaction of the Engineer.

#### **13. VERTICALITY:**

- 13.1** The formal test is not required due to proposed Pumping Plant is of submersible type, although constructed tube well should be vertical and having clear cylindrical space within the housing pipe to accommodate the O.P. Unit for development of Tube Well and also submersible Pumping Plant of requisite capacity with its proper installation and working.
- 13.2** If the housing pipe is so much non-vertical that it could not accommodate a submersible pumping plant of requisite capacity with its proper working up to desired depth then the tube well will be rejected outright, and all expenditure if any done by department on tube well should be recovered from contractor. If there is any dispute in this regard the final decision authority will be chief Engineer (E&M) and whose decision shall be binding to contractor.

#### **14. YIELD TEST:**

The official yield test shall be conducted by department as per departmental norms, but all arrangements for that shall be provided by contractor on his own cost.

- 15** Makes of the procured material must be as per approved list enclosed in tender document and make of those items not mentioned therein, shall be as per prior approval of Chief Engineer (E/M) U.P. Jal Nigam, Lucknow.
- 16.** During test and trial, contractor has to make the arrangement of pump operators, watch & ward with all consumables such as, sodium Hypochloride etc. at their own cost. Failing which, office will make the arrangement of all that as mentioned above and deduction shall be made accordingly at the risk and cost of contractor Rs. 20000/- per month for not providing Operator and hypochloride for Rs. 55.00 per Ltr. It is assumed that operator working all in three shift will also do the work of watch and ward.

#### **17. COMPLETION AND HANDING OVER OF TUBE WELL:**

- 17.1** After giving the official test as above, the contractor shall give sounding of the tube well to the Engineer or his

authorized representative. In case the complete sounding is not found and it is observed that sand is plugged more than half the length of the bail plug, than it will be responsibility of the contractor to clear the tube well at his own cost and risk.

- 17.2 Just after giving the sounding and accepted by the Engineer or his authorized representative, the contractor shall cap the tube well duly welded.

#### 18. PRESERVATION OF EXCAVATED MATERIAL:

As the boring work of Tube Well proceeds, the contractor shall keep carefully notes of all changes of strata after every 3 meters or earlier whenever the strata change and keep its measurement from ground level and shall preserve a sample of soil taken from every strata, each sample must be at least 200 c.c. by volume and must be carefully preserved and marked with the depth and range from which it was taken in transparent packages. The contractor shall also maintain at the site, the boring chart showing daily progress of the work, nature of soil passed through each day and the thickness of each strata and others. The strata samples shall be handed over to the Engineer.

#### 19. SITES FOR TUBE WELL:

- 19.1 The site of tube well shall be shown to the contractor or his authorized representative before starting the work. The contractor is strongly advised to consult strata chart of boring done in vicinity of the place. The strata chart available in the office may be seen but these can be only taken as guide. No claims shall be entertained differs from that shown on those charts.
- 19.2 Contractor shall be clearance of Tw site ,if any dispute at time of construction of Tw by local body , shall be resolved by the contractor

#### 20. FAILURE OF TUBE WELL:

If the tube well fails due to bad workman ship/accident ,non availability of suitable strata ,Loose strata ,unaccepted quality problem aquifers/zones or whatsoever the reason, the department will not make any payment to the contractor for that Tube well and if any expenditure done by department on that tube well will be recovered from the contractor's Security Money Deposit/payments out standing in this division or any other divisions in Jal Nigam.

#### 21. OBLIGATION TO CONTRACTOR FOR SUCCESSFUL TUBEWELLS:

It is obligatory to contractor for constructing the tube wells successfully on account to get maximum sand freedischarge. Department will not make any payment to the contractor for any extra works.

### **Technical / Terms & Conditions**

R.C. Rig Machine and its appurtenant works under Amrut 2.0 programme

1. Cost is to be quoted on percentage rate as per schedule 'G'/ BOQ as specified.
2. Required Tube well assembly and its all accessories shall be supplied by the Contractor as per requirement of site. Technical specification and other data of pipes shall be as per relevant IS and approved make within the list of U.P. Jal Nigam or their latest revision.
  3. Quantities given in schedule 'G'/ BOQ are approximate and average and may vary upto any extent as tube wells are proposed to be constructed in the range up to 200 meter depth.
4. The Contractor has to arrange adequate continuous clear water supply required during drilling and cost of the same should be included in the rates tendered for construction of the tube well is must.
5. The rates shall include the collection and preservation of strata samples taken at every three meters depth and where ever the strata changes, supplying the boring/strata chart immediately after completion of drilling and supplying lowering chart to the deptt. and got approved before lowering and the contractor shall submit finally tube well completion chart.
6. Pea gravel shall be supplied from LAL KUAN quarry (Haldwani, Uttrakhand) which shall be thoroughly washed, graded, screened and stacked properly at site, 5% of quantity shall be deducted against bulk

- age/voids from measured quantity of pea gravel. No extra payment shall be made for stacking the pea gravel in trapezoidal shape on GL near the pin point.
7. Yield test of tube well shall be carried out in accordance with IS-2800 (part II) and detailed specifications given in tender form. In case of any deviation suitable action shall be taken as per CB or decision taken by the competent authority regarding the acceptance of tube well which shall be final and binding.
  8. It is sole responsibility of the contractor to prepare lowering assembly based on the actual strata encountered matching with logging report and then get it duly approved by the Engineer In charge there after the lowering work will be started by the contractor.
  9. The income tax, work contract tax, labour cess. as applicable at the time of payment, shall be deducted at source as per Govt. rules, hence rates should be quoted accordingly.
  10. If required, approach path upto the pin point given would be constructed by the contractor and if any hindrance encountered in making approach path the same will be resolved by the contractor at his own risk and cost. Any damage/loss to public or Govt. properties will be borne by the contractor.
    11. It is sole responsibility of the contractor to maintain health, hygiene and sanitation conforming to SOP promulgated by state of U.P. / central Govt. and guidelines issued time to times by state of U.P. and central Govt. in order to contain Covid-19 outbreak in the country and also, all safety measures to pre-empt any untoward incident at site. Failing which, contractor will have to face prosecution and compensate loss to human's life and property as per law of the land and pronounced judgment of the apex court India.
  12. Site clearance/leveling of site will be done by the contractor after completion of TW construction.
  13. The contractor will have to take all preventive measures with the help support of site in charge to ensure that Tube well construction site is not exposed to risk of accident to the passers by, residents of the

neighborhood or children etc. Until the Tube well construction is complete in all respect. Failing which, contractor in person is liable for prosecution as per law of the land in case of any accident or loss to life and property. **After the successful completion of the tube well all the activities pertinent to safety measures shall be carried forward by the contractor till the site is handed over to the authority concern by the contractor .**

14. Contractor or drilling agency shall be sole responsible for any injury or damage to Tube well assembly while drilling lowering and development works caused by in proper handling of the machine or any gadget or equipment or machine failure. In event of loss to property of the Deptt. shall be recovered from the contractor.
15. Drilling agency shall be sole responsible for any accident due to their negligence, apathetic/ sluggish attitude and shall pay out compensation to the party inflicting any injury or loss to life and property.
16. Engineer in charge is not responsible for acquiring and providing legal and physical possession of the site other than the getting the construction of the tube well is complete at the pin points according to the choice and selection of the concerning authority.
17. Argument or dis argument or spat with site in charge at site or in office with any officers shall be treated as misconduct amounting to cancellation of the contract bond.
18. During development of tube well, disposal of discharged water in general specified by the site in charge will be made by the contractor at their own cost. Unless otherwise unfavorable circumstances
19. After completion of work all pits would be leveled and cleared, excess earth shall be removed from the site by the contractor.
20. Carting of tube well assembly from contractor store to pin point of tube well will be done by contractor on his own cost.
21. Contractor have to provide vehicle (four wheeler and two wheeler) for supervision purpose to the executing staff during the completion period of tubewell construction as per the directions of the engineer, failing which the department shall arrange for the same on the cost of contractor.
22. The contractor must have experience of construction of such type of TWs & the certificate must be attached along with other documents. The contractor has to arrange the following machine / T&P in good running condition for construction of tube wells.
  - (i) Rig machine - R.C. Rig machine 675/600 or as required as per Schedule "G"/ BOQ above with all its accessories, RR bits size 675mm and 600mm for at the minimum for drilling, T&P, welding plant etc.
  - (ii) Compressor- 350/600 PSI compressor with all T&P & accessories
  - (iii) OP Unit- 3 cusec capacity with all T&P & accessories.

Note: Pilot bore is denied as it makes the bore cutting uneven with dismal workmanship that results in excess consumption of the gravel and also creates host of problems in course of development by compressor and O.P. unit.

**Flexibility of the contractors.** This contract provide a certain number of tube wells for construction as per NIT. But the contractor may be called upon to construct further number of tube wells under this contract as it may be necessary as per direction as directed by the competent authority.

## **Conditions for Works includes in Contracts:**

### DETAILED SPECIFICATION

#### **1. Tube well assembly:**

Only 300 mm dia Housing pipe minimum 7.1 mm thick, 200 mm dia minimum 7.1 mm thick plain / slotted pipe of tube well assembly & Tw accessories will be supplied by the contractor as per specifications laid down in various I.S. The contractor has to supply MS rings, reducer, centre guide, Bail plug, housing cover Housing clamps etc all that will be inspected by department before dispatch to individual site at works. Girder of H shape will be supplied as per size mentioned. The installation of tubewell assembly shall consist of M.S. housing pipe 300 mm and 200 mm dia plain pipes and M.S. slotted pipes as per IS 4270 (latest amendment) made from Fe 410 Grade 7.1 mm thick M.S. plate as per IS. The details are as given in the drawing and described below:-

- i) The tubewell shall have a 200 mm dia bail plug at the bottom of a plain pipe having M.S. ring welded at the upper end further 200 mm dia slotted / plain pipe will be joint with the help of M.S. ring welded at upper end. The 200 mm tube thus made will be connected as per approved length will b/w connected to the 300 mm dia housing pipe with the help of 300x200 mm dia enlarger by electric welding. The housing pipe may be increased depending upon the spring level and strata. Housing pipe will be welded with 300 mm dia M.S. ring subsequently as per approved length of tube well assembly. Pipes available may be in 4m to 6 m length.
- ii) The housing pipe shall have to be placed vertically and a tolerance of not more than 50 mm in 25 meters. Through the length of housing pipe will be accepted for any deviation from the plumb. The 300 mm dia and 200 mm dia pipe shall be connected with a reducer. The bail plug shall consist of the lower maximum 6 meter of 200 mm dia blind tubes with the bottom plug capped. The cap shall be fitted with an Iron U hook at least one meter long of 22 mm dia mild steel rod suitably fixed to the bottom bail plug cap. The tube shall finally rest on clay bottom Girders clamps or lending of gravel having a thickness of about 2 meter. All 200 mm dia tube both blind and slotted pipes shall be electrically resistance welded conforming to Indian standard specifications. The weight of tubes shall be as per B.I.S. The M.S. ring will be 12 mm thick sheet welded and shall conform with Indian standard specifications. The housing pipes will be MSERW/ fabricated from SAIL/TATA steel plate in 4 to 6 meter length the without any circumferential weld with Plain ends.
- iii) The 200 mm dia tubes shall centered in the holes by means of mild steel welded spiders at 10 meter of intervals on the blind pipe 200 mm pipes with linear slots of suitable sizes to have water way area of 16% of total pipe area will be used. The slotted pipes may be used in any lengths required by the water bearing strata but no piece shall be less than one meter in length. The slot should be milled and not punched previously. No slotting with any acetelyne flame for perforation of the liner will be accepted.

### 1. Tubewell Accessories :

- a. **Well Cap** :- Well cap made out from 150x12mm M.S. Flat, 6mm thick top sheet with a handle on top suitable for M.S. housing pipe 300mm dia.
- b. **Housing Pipe Clamp** :- Housing pipe clamp made out from 16 mm M.S. Flat, with 300mm long armon both ends having drilled holes and fastened by means of 4 Nos. ½ dia 6” long nut, bolt & washers suitable to clamp 300 mm dia M.S. Pipe.
- c. **M.S. Ring 300 mm dia** :-  
M.S. Ring RING made out from 150x12 mm M.S. Flat, suitable for M.S. pipe. The rings has to be tapered with 'V' groove at both ends and seat in between. 300 mm dia M.S. Pipe`
- d. **M.S. Ring 200 mm dia** :- MS ring made of 150 mmx12mm ms flat suitable for ms pipe the ring has be tapered with V groove at both ends and sheet in between suitable for 200 mm dia
- e. **MS Bail Plug**:  
M.S. BAIL plug made out from 150x12mm flat with 'U' hook of 25mm dia M.S. Rod 500mm long high bolted at bottom of BAIL PLUG suitable for 200 mm dia M.S. Pipe
- f. **Centre Guide**: - Centre guide length 900 mm ,220 mm dia made from 40 mm thickness of M.S. flat strip IS code- 226 : 1975. 8 nos each tubewell assembly.
- g. **MS Fabricated Tubewell support**:- Tubewell support made up of 200x100 mm size MS girder having 2.5 m long in H shape as per departmental design.

### 2. Specification of pea Gravel :-

Gravel packing shall be done by suitable method approved by the Engineer or his authorized representative. The placing of the gravel in the annular space between the well pipe and the hole shall start at the bottom of the well and extend upward to ground level. The construction of the gravel filter once started will be continuous operation until it is finished.

The following specifications are to be followed for supply of Pea Gravel for Tubewell.

1. The Gravel has to be supplied from Lalkuan, Query Haldwani and conforming to IS 4097-1967 and as latest amendments.
2. The average particle size of Gravel shall be 1.6 to 4.8 mm.
3. The Gravel shall consist of hard quartz (about 96% SiO<sub>2</sub>) or other suitable material, with an average specific gravity of not less than 2.5. Not more than 10% by weight of the material shall have a specific gravity of less than 2.25. The Gravel shall contain not more than 2% by weight of thin flat or elongated pieces. In case of such pieces, the larger dimensions shall not be more than 3 times the smallest dimensions. The quartz shall be of sub rounded to rounded grains with minimum angular features.
4. The Gravel shall be free from impurities, such as shale, mica, feldspar, clay, sand, dirt, loam hematite and organic materials.
5. The particle size distribution of Gravel may be Determine by screening through standard sieve accordance with IS: 460.
6. The gravel shall have a hardness of not less than 5 in Mohr's scale.
7. Voids @ 5% shall be deducted from quantities measured at site.
8. Any tax, Royalty shall be included in the offered rates.

### 3. Development by Air Compressor:

The tubewell shall be developed either by surging, including washing and agitation by air compressor or by over pumping and back

washing with or without an air lift. The development of tubewell by air compressor process shall be continued until

- (i) The tubewell ceases to absorb further gravel.
- (ii) The depression ceases to improve.
- (iii) The discharge ceases to improve.
- (iv) The water is reasonably sand free.

The analysis of sand content will be carried out by the contractor as per written instruction by the Engineer. The sounding of T/W will be taken after development by air compressor and OP unit.

The contractor shall over develop so as to yield a discharge 20% in excess of the rated discharge or to depress the well to 50% higher than the nominal depression at which the tube well is pumped on continuous duty which ever may be more. The discharge during development shall be measured at minimum intervals of 6 hours over a V-Notch weir or by other suitable method may be accepted and record kept as previously provided. The development will continue till no further feeding of gravel is found necessary and the discharge is free of sand within the requirement of specifications. The discharge shall be sand free i.e. sand contents will be less than 10ppm in the final discharge of the tube well obtained after 05 minutes of starting and clear/traces within 10 minutes. The discharge of tubewell shall be measured by means of water meter or orifice meter or rectangular V-notch chamber constructed according to ISS such that the full size discharge from the outlet pipe the plumb will fall into the first compartment of V-notch chamber. In order enable the collection of water in a bucket for measuring the sand contents of water a bib cock shall be provided in the delivery pipe away from the discharge outlet. The contractor will also provide necessary measuring jars. The yield of the tube well will be carried out as under:- Firstly, the discharge of the tube well will be increased in stages at an interval of one hour and relevant readings at each stage will be recorded by checking these readings. The most suitable discharge will be selected and the tube well will be run for about 6 hours and the readings of depression and discharge will taken after every half an hour for ensuring the figure of discharge and depression remain steady during the entire period of test. The specified discharge of the tube-well shall be obtained at a depression not exceeding 20 ft. Thereafter the recoument test of the tubewell will be conducted by noting the readings of recumbent of water level in the housing pipe by noting the depth of water level from the top of the housing pipe after suitable intervals/ Cleaning of water after stopping pumping.

#### 4. Abandonment of Tubewell:

During construction it may be required to abandon the tubewell due to negligence of the working staff of the contractor, in such case no payment of the executed work will be made to the contractor. If during drilling very hard rock or boulders or uncontrollable caving strata is met and also if due to any natural reason i.e. connecting the well with any nearby natural well and it is not possible to drill further or no strata is met, No payment of the such drilled borewell will be made by the department. However the contractor for at least 48 hours in case of hard rock, try to penetrate it in presence of the Engineer in-charge for 24 hours and if the progress is less than 1 feet in 24 hours and sufficient strata has not been met to yield required discharge, the bore may be declared as abandoned and for which no payment will be made.

#### 5. Quality of Water:

In the construction of the tubewell, due precautions shall be taken by the drilling agency to maintain the premises in a sanitary condition and to avoid as much as practical, the entrance of contaminated water into the safe water bearing formations, any water or materials used shall be free of contamination and, if their nature permits, should be adequately disinfected with chlorine before use. The slush pit should be constructed so that no material there from will enter the well, except mud reused when the construction is by rotary method. In such cases the slush pit and mud return channels should be protected against contamination from surface water or any other sources.

### TECHNICAL SPECIFICATIONS FOR SUBMERSIBLE PUMPING PLANTS WITH ACCESSORIES

#### 1. SWITCH GEAR:

Complete switch gear with all equipment, accessories shall be supplied and erected by the contractor with the provision for connecting to the  $400 \pm 10\%v$ , 3 phase 50 Hz A.C. supply system at tube well pump house. Under this item, following equipments shall be provided:

##### 1.1 STARTER/ PUMP CONTROLLER

Supply of SCADA compatible Fully automatic Pump motor starter for Tube well application with following Automation, protection & metering features for Star Delta operation **Approved make**. This shall be a 18 SWG sheet fabricated cubical wall mounting type dust & vermin proof panel having front opening door complete with hinges, glands for

cables etc. and with internal control wiring with 1.5/2.5 mm<sup>2</sup> PVC insulated & sheathed cable and consisting of the following.

Confirming to IS specifications & have at least 1NO+1NC auxiliary contacts.

3 Phase 400 ± 10%v, 50 Hz

consisting the following.

- a. Air break power Contactors of suitable rating (Main, Star and delta contactors).
- b. Electronic motor protection Relay of suitable rating with Phase Reversal relay, Single Phase preventer, reverse phase, phase unbalance voltage & current, over & under voltage
- c. Electronic star delta changeover timer
- d. Push Button switches.
- e. electronic Amp & Volt meter
- f. Ampere meter selector switch.
- g. Capacitor of suitable rating.
- h. Current transformer for metering-03 nos
- i. 1 No. Fuse element of automatic cut-out for the control circuit.

1.2 Suitable capacity of main switch for the pumping plant

### 1.3 **POWER WIRING AND EARTHING**

#### (a) **Power wiring:**

- (I) 70 meters approved make PVC insulated 3 core flat copper submersible cable of required size, 1100 V grade confirming to IS 694 part I shall be supplied to carry out power wiring from submersible motor to starter. The submersible cable shall be fixed to the M.S. column pipes by suitable cable clamps. The length and size of the cable should be mentioned by the tenderer.

From starter to control panel and control panel to 200 amp. kit kat power wiring done by suitable size PVC insulated separate copper lead for each phase and Neutral. To connect to UPPCL energy meter 2 meter Leads should be left spare for making connections. The size of the submersible cable should be adequate to take starting current of motor after taking into account derating factors at 45<sup>o</sup> ambient temperatures.

- (II) 45 cm × 45 cm 12 mm thick hard board with sun mica top board with 3 nos. porcelain cutout and neutral link of required capacity with angle iron frame as per design of department.
- (III) Board of required size and capacity to mount tools.
- (IV) 12 mm thick Rubber matting 1 meter × 1 meter size.
- (V) Suitable size aluminum armored cable 3.5 Core, main switch to transformer

#### (b) **EARTHING:**

Double plate earthing of the entire electrical system shall be carried out and connected to permanent earthing plates buried in ground and surrounded with coke salt upto adequate depth where earth is encountered. It shall be consisting of the following:

- i) GI Earth plates of 600 X 600 X 6 mm size as per latest relevant ISS/IER.
- ii) GI water pipes of required length and 40mm dia. As per latest relevant ISS/IER.
- iii) Aluminum Earth strip of adequate size as per relevant ISS/IER and in required quantities to cover complete installation in double run. The strip shall be without kinks and without any joints.
- iv) Necessary quantities of lugs and clamps etc. for proper earthing.
- v) Necessary quantities of salt and coal.
- vi) Earth chamber CI box 300 X 300 mm as per ISS/IER.

#### NOTE:

- i) The digging of pits for earthing and construction of suitable size earth chambers shall be done by the tenderer.
- ii) The whole of the above work of power wiring and earthing shall be carried out to the entire satisfaction of Engineer Incharge and subject to the approval of UPPCL and be in accordance with IER and other Govt. regulations prescribed/amended upto date.
- iii) The power wiring shall be done properly on MS clamps to be grouted in wall. The submersible cable/copper lead will run through MS conduits on wall and floor.

## **2.0 SUBMERSIBLE PUMP SET WITH SUBMERSIBLE MOTOR:**

Submersible pumping set suitable for 300 mm dia T/W Bore fitted with dynamically balance bronze impellers mounted on a stainless steel pump shaft with shaft protection sleeves having stage bowls of closed grained cast iron. The pump will be fitted with built in non-return valve and shall be suitable for direct coupling to the squirrel cage electric induction, water cooled type submersible motor suitable to operate on  $400 \pm 10\%$  V, 3 phase, 50 cycles/sec. A.C. Power Supply and 2900 rpm (nominal) speed and having following duties as given below-

### **2.1 Pump Set:**

- 2.1.1 A Standard hydrostatic test on all pressure containing parts shall be made at 1.5 times the maximum discharge pressure.
- 2.1.2 The bowls shall be equipped with replaceable casing bearing.
- 2.1.3 The bowl assembly shall bear a name plate preferably embossed information as per following:
  - a) Name of the manufacturer or trade mark.
  - b) Serial number of the pump set.
  - c) Pump type.
  - d) Number of stages.
  - e) Total head.
  - f) Capacity.
- 2.1.4 The impeller shall be of enclosed type equipped with seal rings on their hubs. Seal rings shall be provided either with impeller or in the bowl.
- 2.1.5 The pump shaft shall be guided by bearing provided in each bowl of above and below the impeller shaft assembly. The shaft without sleeves shall have a surface finish 0.75 micron Ra Max.
- 2.1.6 The opening in the suction case for the entrance of water shall be of proper size and shape to avoid eddy currents.
- 2.1.7 The suction case shall be fitted with a strainer made of corrosion resistant material.
- 2.1.8 Suitable sand guard shall be provided just above the suction case bearing to prevent the entry of foreign matter into the suction case.
- 2.1.9 Non return valve shall be provided above the pump discharge case.

### **2.2 SUBMERSIBLE MOTOR:**

- 2.2.1 The submersible motor shall be squirrel cage induction motor.
- 2.2.2 The winding of motor shall be wet type.
- 2.2.3 The motor shall be suitable for operation voltages and frequency confirming to IS 585-1962 (revised) "Voltages and frequency for A.C. transmission and distribution system"
- 2.2.4 The earthing of the motor shall comply with IS: 3043-1966 code of practice for earthing.
- 2.2.5 The Thrust bearing shall be of adequate size to withstand the weight of all rotating parts as well as the imposed hydraulic thrust. These shall be lubricated suitably.
- 2.2.6 The Motor winding and nearing bushes of the rotor shaft shall be cooled/lubricated by pure water filled in the motor before erecting the pump set.
- 2.2.7 The motor shall be protected by means of cable glands, rubber seals etc. from ingress of tubewell water, sand and other foreign matter.
- 2.2.8 The thrust bearing housing shall be provided with a drain plug to empty the pure water filled into the thrust bearing housing/Motor.
- 2.2.9 The rotor shaft shall be provided with shaft protecting sleeves having a surface finish of 0.75 micron Ra max.
- 2.2.10 The Motor shall be provided with a breathing attachment like bellows, diaphragm etc. to compensate the Volumetric variations due to change in temperature.
- 2.2.11 The motor shall be made of corrosion resistant materials or suitably treated materials to resist corrosion.
- 2.2.12 The motor shall have a name plate preferably embossed on body of motor giving the following information :
  - a) Submersible Motor;
  - b) Name of Manufacturer;
  - c) Manufacturer's number and frame reference;
  - d) Type of duty;
  - e) Frequency in Hz;

- f) Number of Phases;
- g) Rated output in HP/KW;
- h) Rated voltage and winding connections;
- i) Current in amperes at rated output.
- j) Speed in RPM at rated output.

**2.3 DATA OF PUMP SET:**

These shall be furnished in the following manner:

- a) Make of motor
- b) Model of motor.
- c) Model of pump.
- d) Discharge in LPM.
- e) Total head.
- f) Net effective head.
- g) Number of stages.
- h) Pump outlet size in mm.
- i) O.D. of pump in mm.
- j) Speed of pump set.
- k) Method of starting.
- l) Size of Cable
- m) Motor HP
- n) Length of cable with motor

The performance details as per enclosed schedule 'E' are to be submitted separately.

**NOTE:-Motor H.P must be as per CPHEEO manual**

**3.0 MAIN PIPING AND VALVES**

**4.0 1 Set**

Under this item, supplies shall be made as per following specifications:

**TENDER SPECIFICATION FOR VALVES & GATES**

**1. Non-Return Valve/ Sluice valve suitable size**

Non-Return Valves shall be Resilient Seated and shall be confirmed to the EN1074-3 standard. Non-Return Valve shall be Slanted seat & swing type. Body, Cover shall be of Ductile Iron (GGG40), Disc/Door shall be of Ductile Iron (GGG40) with fully encapsulated with EPDM Rubber. Valve should be suitable for 16 bar pressure.

Non-Return Valve shall be double flanged type. The flange drilling dimensions shall be in accordance with IS 1538:1993/IS 9523:2000. Face to face length of the valve shall be as per IS 5312 (Part 1) / EN558:2008 Series 10

The material & specification for different component parts of non-Return valve given below:

Component	Material & Specifications
Body Cover	Ductile Iron, DIN1693 GGG40 / IS:1865 Gr. 400-15
Disc/Door	DIN1693 Door Ductile Iron GGG40 / IS:1865 Gr. 400-15 with fully encapsulated with EPDM Rubber
Gasket	EPDM Rubber Bonnet
Bolts	Stainless Steel, AISI-304 (A2)

Marking on the valve body shall be as cast and 1) Brand/Logo, 2) Size, 3) PN Rating, 4) Heat No., 5) Flow Direction marking should be provided. Valve shall be coated with epoxy paint (Blue, RAL5005), and minimum DFT shall be of 250 microns.

Hydrostatic test of the valve shall be conducted as specified in the IS 5312 (Part 1) / EN1074-3 standard. Body Test shall be 1.5 times of the rated pressure (duration 5 minutes) & Seat Test shall be 1.0 times of the rated pressure (duration 2 minutes).

### 3.1 Main Piping and valves

Under this item supplies shall be made as per following specifications and relevant ISS.

150 mm dia column pipe with 7.1 mm thickness as per IS and having special M.S flange welded at both end duly painted with Anti corrosive paint with groove cutting for submersible cable and M.S. top flange. 24 mt.

- |    |   |        |
|----|---|--------|
| 1. | 150 mm dia DI D/F 90° heavy duty bend                 | 01 no  |
| 2. | 150 mm dia DI A/F heavy duty tee                      | 01no   |
| 3. | 150 mm dia M.S. D/F 7.1 mm thick ms pipe 1.5 m long.  | 02 nos |
| 4. | 150 mm dia M.S. D/F 7.1 mm thick ms pipe 1.0 m long.  | 01 no  |
| 5. | Necessary Nuts and Bolts and rubber packing GKW       | L.S.   |
| 6. | M.S. Enlarger for submersible pump (if required.)     | 1No    |
| 7. | 150 mm dia heavy duty column pipe clamp with Nut bolt | 2 pair |

### 4.0 LIFTING TACKLE: -

Under this item the contractor shall provide **1 No** spur geared chain pulley block of capacity 2.0 Tons, tested to 3.0 Tons with load and hand chains for 4.5 meters lift approximately along with test certificate. The make of chain pulley block shall be "INDEF" or "MORRIS".

### 5.0 Tools and Spanners: -

Under this item you have to supply the following materials:

- |  |         |
|--|---------|
| a) Hammer with handle  | 1 Set.  |
| b) D.E. spanners consisting of 8 pieces. (Everest/Tapria make) | 1 No.   |
| c) Screw driver 12" and 6". (Everest/Taparia make) one each    | 1 Set.  |
| d) 350 mm. size pipe wrench. (Everest/Taparia make)            | 2 Nos.  |
| e) 150 mm dia column pipe clamp with nut bolts                 | 2 Nos   |
| f) 200 mm insulated plier 'Everest/Taparia' make               | 2 Pairs |
|  | 1 No.   |

### 6.0 Pumping Plant Accessories.

- |  |       |             |
|--|-------|-------------|
| 1. M.S. Tube well housing cover. (Dum Dum) suitable size.  | 1 No. |             |
| 2. 750x450 mm size instruction board of 15 mm thick Fiber with at corner and written of Jal Nigam instruction with monogram. | 1 No. | bidding     |
| 3. 1.25 M x 1.25 M size M.S. housing cover of 3 mm thick M.S. Sheet in 2 locking arrangement & duly painted.                 | 1 No. | pieces with |
| 4. 225 mm outer dia M.S. cross ring fabricated of 25 mm M.S. iron bar duly painted.  | 1 No. |             |
| 5. Orifice Pipe 150 mm dia 0.45 Mt. long with 12 mm thick M.S. Flange welded at both ends with painting.                     | 1 No. | duly        |
| 6. Interlocking of submersible pump and motor by 40x6 mm M.S. Flat with weld nut & bolt on 1.0 Mtr. long pipe.               | 1 No. | Strip       |

### 7.0 PAINTING:

Under this item all parts of switch gear, accessories, piping and other iron or steel work not finished bright shall be painted with two coats of approved and good quality synthetic enamel paint which shall be applied on above parts after erection.

### 8.0 ERECTION: -

Under this item the contractor shall undertake complete installation of switch gears and pumping plant including power wiring and earthing of electrical items, main piping and valves with required minor civil works such as cutting of walls/repairing and setting to work of the plant.

### 9.0 TESTING OF EQUIPMENTS:

The contractor shall provide preliminary testing of pumps ,valves and other e&m equipments at manufacture's works and at site also through testing of the whole plant during the course of erection and when it is completed as specified and for official testing of the same in accordance with schedule 'E'

## 10. TECHNICAL SPECIFICATIONS OF SERVO VOLTAGE STABILIZER-

The Servo Voltage Stabilizers shall be as per following technical specification.

1. Stepless and high speed Voltage correction without over shoot/ hunting.
2. Push Button to raise / lower output voltages.
3. Easily replaceable plug-in circuit card.
4. Potentiometer to adjust output voltage of phase on Front Panel.
5. Burn Proof/ Brush A.C. synchronous motor for greater reliability and longer life.
6. Online serviceability with inter changeable plug-in Control Card.
7. High accuracy from No load to full load.
8. High performance integrated circuit based, control system.
9. Mains ON indication on front panel.
11. System construction as per latest revision of IS 9815.
12. Input / output voltage selector switch.
- 13 Acoustics less than 50db.
- 14 Digital Ampere & Digital Voltmeter with indicators for each phase.
15. Other features as per following table:

**S.No. Features Minimum Requirements**

- a CAPACITY As requirement
- b INSTRUMENT TYPE Indoor Floor Mounted
- c TYPE OF COOLING Oil Cooled
- d INPUT 230 volt + 1%
- e OUTPUT 415V + 1%
- f OUTPUT VOLTAGE From no load to full
- g SUPPLY FREQUENCY 50HZ + 1%
- h INSULATION RESISTANCE 5 megohms or higher measure at 500 V at room temperature not exceeding 55oC
- 9 PROTECTION
  - a Under Voltage/Over Voltage cutoff
  - b Time delay & Single phasing
  - c Overload cutoff through MCCBc Single Phase Preventer
  - d Change over switch
  - e Spike suppressor
- 10 WAVEFORM DISTORTION None
- 11 EFFICIENCY Better than 98% on full load
- 12 OPERATION Fully Automatic/ Manual
- S.No.18 Features Minimum Requirements
- 13 SPEED OF CORRECTION >. Than 20 V/Sec
- 14 PERFORMANCE Free from HUNTING during operation
- 15 METERING Should have digital AC voltmeter with selector switch to indicate input/output voltages
- 16 TYPE OF LOAD Balanced
- 17 CONFORMANCE Servo Stabilizer should fully conform to latest version of IS:9815 Standard
- 18 AMBIENT TEMPERATURE 00 TO 55O C at 90% R.H.
- 19 OVERLOAD CAPACITY 125% for continuous 4 hours with no performance deterioration and no long terms effects

**A. TEST DUTIES AND EFFICIENCIES:**

The contractor shall state in the tables attached with tender documents the efficiencies and duties of the pumping plants when working at specified conditions of the pumping and the guaranteed performance in K.W. hour input per water horse power output under various conditions of working. The guaranteed performances are also to be specified under following conditions

i.e. variation in head discharge and power consumption in the following cases:

When available voltage decreases from 415 volts to 380 volts or increases from 415 volts to 440 volts.

When there is fluctuation of  $\pm 3\%$  in the frequency of the AC power supply from 50 C/S.

When there is above change in voltage and frequency of the AC power supply simultaneously.

The official tests shall be conducted in two stages. Preliminary tests may be conducted at the manufacturer's works. The final tests shall be conducted at site. Pumps shall be run so as to obtain the range of heads specified in the performance tables by means of throttling or opening valves of the pumping mains and tests results will be compared with those guaranteed by averaging the units consumption per water horse power hour.

The guaranteed figures stated above shall be subjected to no tolerance and the average results shall be obtained during official test of plant. If the results lack average guaranteed figures the contractor shall forfeit followings ascertained damages relating to each set installed.

If BOT unit (KW) per WHP), the consumption is above the average guaranteed figure under the specified Q and H, the liquidated damages will be recovered as the capitalized cost of the Extra Energy Consumption during the useful life span 15 years of the pumping set. The liquidated damages shall be calculated as below:-

Cost of extra power consumption

to be recovered shall be equal to = Cost of extra power per annum X capitalization factor for 15 years at an interest rate of 9%.

No damage will however, be recovered if the consumption is less 0.05 BOT units per WHP above the guaranteed.

If on testing the discharge of pumps is found to be within the permissible limit of  $\pm 4\%$  then the pumping plant will be accepted without imposing any penalty. If discharge is

less by 5% to 10% then pro rate deduction @ 1% of the cost of pump and motor for less percentage of discharge shall be made and further if the discharge is less 10%, plant will be rejected.

It may be noted carefully that no privilege shall be given to any offer for evaluation purposes considering the efficiency of the pump and Motor. Better efficiency pump and motor however shall be preferred. For evaluation purposes pump and motor efficiency shall be considered as 72% & 82% respectively but pump will be tested on the efficiency quoted by the firm in schedule-E of their tender.

The pump efficiency offered below the efficiency quoted shall be considered for evaluation as follows:

Electric charges shall be based on 20 hours of operation per day for 15 years at the prevailing rate of Electric Charges.

All future costs of yearly power consumption will be capitalized to present value at capitalization factor @ 9% interest.

The tenderers shall have to consider the condition of pumps being run at shut off head under the pump duty variation condition as narrated above. The tenderer should ensure selection of pumps considering shut off head at least 25% more than the duty head. However the motor should be selected as per tender specification and scope of work defined. The possibilities of change of duty point of each pump in parallel operation can not be ruled out , under such condition tenderer should select the pump carefully.

Penalty for delay in supply and installation-0.25% per day of the total tendered cost subject to a maximum of 10%.

#### **COMMISSIONING:**

After intimation, contractor will commission the pumping plant within 10 days' time. During trial run period the contractor shall depute his skilled staff for trial run.

#### **TRIAL RUN & DEFECT LIABILITY PERIOD:**

The contractor shall provide necessary staff for operation and maintenance of the pumping plant, including watch & ward just after successful commissioning. trial run period will start after commissioning of pumping plant as per satisfaction of department/Engineer in charge and defect liability period of 24

months will start commissioning, during this period except Power all consumables shall be provided by the contractor free of cost including watch & ward of pumping plant for 24 hours per day He shall depute qualified persons with necessary experience and know how to operate pumping plant. No extra payment shall be made for any spare part during the trial run and defect liability period this period.

**Note:-** i) Characteristic curve duly certified by manufactures and duty point marked shall be submitted (Head V/S discharge, efficiency V/S discharge and power output V/S discharge).

i) The pump shall be installed as per available discharge & required head as per site conditions.

**10.0 GAURANTEE – All the Pumps/machinery shall be guaranteed for period of 24 months from the date of commissioning. Contractor will give a written guarantee certificate for the same, without which no payment shall be made.**

❖ **Special Instruction to the bidder**

1. Bidder has to mention the complete model no. of quoted items / instruments in their bid documents which they are offering to us.
2. Bidder has to submit the detailed catalogue of the product offered and same catalogue must be available on company website.
3. Bidder has to highlight the technical Specification in the catalogue as per our technical Specification against each in every item. In case if there is any deviation, bidder has to clearly confirm the same otherwise it will be assumed that bidder confirms to all the specifications in the tender.
4. All material is subject to third party inspection mandatory by National/International reputed organizations like PDIL, LLOYDS, RITES, BHEL, TATA PROJECTS etc as well as by client / UP Jal nigam & charges related to that will be borne by bidder/supplier.
5. Type test mentioned in the technical specification sheets against each and every item are mandatory and bidder has to submit type test copy from National / International Labs. Type test shall be directly from the manufacturer.
6. Bidder has to submit QAP after award of contract & inspection and testing will be performed as per QAP.
7. Bidder should have inspection facility traceable to national/ International standard.

**Technical Specification of SCADA for Tube wells-**

➤ **Architecture**

The SCADA architecture shall provide the following:

1. Client / Server architecture based on TCP/IP networking
2. Standalone single server operation.
3. Additional servers for client load sharing and remote locations.

4. Permanent Standby Server designed to be placed outside corporate firewalls providing a read-only access to the server while ensuring corporate security.
5. Fully automated data transfer between servers to provide complete server redundancy. This transfer shall include configuration, real-time data, historic data and event lists. Database updates shall be on an incremental basis with tuneable parameters
6. A stable fully distributable architecture providing as per engineering station.
7. Where multiple servers are deployed, the system shall be capable of being configurable from a single client.
8. Hot Backup Redundancy shall be provided at Main Control Room PLC. SCADA System shall be provided as below:
  - Engineering cum Operator Work Station loaded with Runtime & Development SCADA Server & Logic Developer.
  - Operator work Station, loaded with Runtime SCADA Server.
9. Forced changeover between main and standby allowing seamless changeover without shutting down.
10. Clients to connect to a synchronizing server as soon as the configuration and current data in the database has synchronized. Incomplete data sets as per clients request on event or trend provide indications that the synchronization is still in progress to ensure that conclusions are not drawn from incomplete data sets.
11. Configurable compression of data communications between client/server and server/server to allow optimisation of communications performance over WAN networks.
12. Change reporting on Client/Server and Server/Server links rather than polled communication to permit operation on WAN networks.
13. Capable of operating Client/Server and Server/Server links over low to medium speed channels depending upon database size.
14. Application shall be native 32-bit and 64-bit versions and supported on Windows® Server and Workstation operating systems including Windows 2000, Windows XP, Windows 2000 Server, Windows 2003 Server, Windows 7 (32 and 64 bit) and Windows Server 2008 R2 and later.

## ➤ **Database**

The SCADA database shall be of true database design and optimized for real-time SCADA operation. The database shall be object oriented and organized in a hierarchical structure.

Templates of Standard configuration shall support multiple object types including, but limited to:

- Point/ Tag objects
- PLC or RTU objects
- Mimics or Graphic display objects
- Trend objects
- Schedules
- Link objects

The SCADA database shall allow users to extend the database scheme to store custom data, in either the configuration or data stream. These changes can be performed online without need for server restart.

## ➤ **Operator Interface**

1. SCADA software shall provide the ability to support multiple local and remote display clients.
2. Display facilities shall be available via LAN, WAN and dial-up connection.
3. Rich Clients shall support database management and configuration changes.
4. Rich Clients shall support multiple monitors (multi-head display), allow logon for all heads from a single location. The system should also provide navigation facilities such that displays on each head can be controlled from any head. (yoking)
5. Integrated Web Sever capability shall be available, providing all display and operational facilities of the Rich Client without the need for additional software to be installed.
6. Web Clients shall allow users to view Mimics, Trends, Database Objects, reports as well as perform control functions using a standard web browser.
7. Changes made to the SCADA server shall require no additional steps to be performed in order for those changes to be available to Rich Clients and Web Clients.

8. Rich Client shall be configurable to connect to one, or multiple server systems
9. Full function display clients shall automatically fail-over & reconnect to a redundant server node when server change-over occurs.
10. Look and feel shall be provided by the SCADA system operator interfaces, including provision for "favourite lists".

➤ **Mimics / Graphics**

SCADA system Mimics shall support a wide range of graphical facilities. Scalable Vector Graphics are required in order to permit operation of the SCADA system with different resolution clients operating simultaneously. Fixed resolution bitmap graphics are not acceptable.

1. Mimics shall be multi-layered, object oriented and permit mimics to be embedded in other mimics.
2. 24-bit Colour shall be supported on mimics as standard.
3. Mimics shall support the ability to specify OPC data source information to display directly on the mimic. This permits data from other systems to be seamlessly integrated in to the SCADA display.
4. Objects embedded and displayed on any mimic shall be viewable through both the full function client and web client displays.

➤ **Start-up**

The SCADA system shall start-up unattended, and without compromising system security

➤ **Configuration**

The SCADA software shall provide full seamless On-line configuration of all database parameters including but not limited to:

- Communication channels
- PLCs
- Points /Tags
- Sequences
- Schedules
- Alarm redirection
- Mimics / Graphics
- Trends/ Graphs
- Reports

All aspects of the look and feel of the SCADA system, including default field values, shall be configurable. It is not acceptable for colour regimes, communication parameters and other aspects of the system to be hard-coded.

It shall be possible to add user defined fields to the SCADA database. These fields should be accessible both internally and externally to the SCADA system; being exposed via OPC, ODBC, OLE Automation, XML/SOAP, etc.

The SCADA server shall provide detailed diagnostics concerning its internal operation. The diagnostics shall be available through capture to a log file as well as online locally on a server and remotely via Telnet and Web interface.

Stored configuration records should be maintained in the historic database for a configurable time period, support redundant SCADA server configurations and allow access from standard database interfaces such as queries and simple mechanisms for displaying and filtering the configuration records.

➤ **Alarm Management**

The alarm system shall provide facilities where actions can be triggered by alarms. These facilities shall be provided as a built- in integrated part of the system and include, but not be limited to the following:

- Configuration criteria for alarm actions
- Escalate Alarm priority

- Delivery of Alarm to user via SMS
- Delivery of Alarm to user via E-Mail
- Trigger other actions including sequences

Where a full function Rich Client is connected to multiple SCADA systems, alarms from all systems shall be combined and filtered, based on user privilege and areas of responsibility.

Consequential alarms to allow one (or more) alarms to be suppressed as the result of another alarm occurring. Suppressed alarms will be received and processed by the SCADA Server and recorded in the event journal for future auditing, however the operator shall not be forced to take an action on an alarm where the cause is known.

### ➤ **Event Journal**

The system shall provide, as a built-in feature and without the requirement for custom or external software, facilities for event logging. These facilities shall be separate from the alarm list and include the capability to insert user comments at any place in the event list.

### ➤ **Historical Data**

The SCADA system shall provide a built-in data historian with the following facilities as standard features.

These shall be provided without the addition of external software modules:

- Time-series relational data base
- ODBC/SQL interface to historical (Trend) data.
- Historical data to be stored with time stamp, point quality, Alarm status
- Historic storage is to be based on configurable criteria including time between samples, alarm state change
- Compression capability

### ➤ **System Security & Access**

The SCADA system shall provide a high level of inherent security. To this end the SCADA software shall provide security access down to data point level, and support individual Users, User Groups and a matrix of system capability and access to any level of the SCADA database.

Full function Rich & Web client interfaces shall require explicit administrative configuration to valid Connection to the SCADA server.

The SCADA system security shall provide the ability to be integrated with Windows domains to Authenticate logon attempts against a trusted domain.

### ➤ **Open Connectivity**

To provide easy access for customized reports and external data manipulation the SCADA software shall provide inherent OPC and ODBC database connectivity without the need for additional software options or modules. Integration with desktop Microsoft products is essential.

### ➤ **Reports**

An integrated reporting package shall be able to generate, print and export reports:

- Triggered by SCADA events
- On user demand
- On time schedules

Reports shall be able to be generated in a number of formats including:

- HTML for viewing via Web interface
- CSV format
- M.S office® suite format

Generated reports shall be able to be:

- E-mailed to assigned user

➤ **Standard Drivers**

The SCADA system shall provide native support for fully integrated Wide Area SCADA PLC protocols. This shall include the capability for supporting all protocols in redundant SCADA server configurations and support redundant communication paths.

Apart from PLC and RTU communication drivers, the system shall also support as standard the Following drivers:

- SMS (with TAP and UCP service) to mobile phones
- A full function system is required including calendar-based rosters
- SNP- monitoring of network devices such as routers, computers, UPS etc.
- NTP – time sever monitoring and alarming
- ODBC – query data from other databases
- Windows Performance Monitoring
- OPC-DA driver

Capacity Description	Size
Number of SCADA I/O Device Subsystem servers	for 20
Number of SCADA Cluster servers for Trending, Alarm and Reporting	for ---20----- TUBELS
Number of SCADA Client Stations	for ----20-----TUBELS
Number of field devices	for ----20----- TUBELS
Physical I/O tags being read/written to field controllers	Unlimited and demonstrable to >1000000
Internal I/O tags within the SCADA networked system	Unlimited
Alarm tags	> 100000
Analog trend tags	> 20000
Average refresh time on a graphic display	< 1s
Average recall time for historical trend values	< 5s per day of data

**2:- Common Technical Specification for PLC System**

➤ **Processor**

- The processors must have an internal non-volatile memory to store application and data.
- It must be possible to connect a PC (programming terminal) or a human – machine interface
- The range must provide processors with at least 3 built – in Ethernet ports featuring a web server compliant with various operating system: minimum is Windows, IOS, and android.
- Embedded web server must provide CUP diagnostic, including **detailed information on Ethernet system networking.**
- The Embedded web server must be customizable by the user to display application variables and advanced diagnostics features. Each processor should have a savable real – time clock which manages

1. The current date and time

2. The date and time of the last application shut-down. The date and time should be managed even when the processor is switched off for 20 days.

- The processors must be equipped with ground connection contacts without additional cabling.
- The PLC must be able to load the program with the use of the memory cartridge.
- Possible to add modules or add remote I/O islands in the configuration without interrupting the running process.

### ➤ Operating system

The operating system (OS) must be capable of multitasking with up to 4 periodic tasks and more than 60 event or I/O tasks.

Physical input can be program to prohibit any modification or downloading of the program.

Outputs can be set to fall back position when the PLC switches to STOP mode via channel by channel parameter entry.

Able to **set breakpoints and watch point** in application to check all system and data when executing application for debugging. System must also provide Step-by-Step running feature to execute all operations one by one in the application. Engineering tool must provide a trending tool embedded to display variables at a minimum of **1ms sampling rate**

### ➤ Memory

Application memory execution can be done on through embedded or removable memory.

**No battery supply is needed for non-volatile backup.**

The processor must provide minimum required of on board non-volatile memory

Feature to store the program, comments and symbols in the PLC. The "empty terminal" functionality must be possible whichever IEC language is used. It must be also possible to use the memory extension to back up files (production data, recipes, etc.)

### ➤ Communication

Synchronized and unsynchronized drops with PLC scan can be **managed over standard and open Ethernet communication.**

Must provide exchanges of variables:

- Explicit exchanges (via function blocks integrated in the application)
- Implicit exchanges (Using cyclical variables generated by the single declaration of the device)

Dedicated function blocks should be available.

The PLC must be accessible via Ethernet (from a remote site) using a standard Internet browser or any other platform (android, iOS). These functions must not require any prior configuration or special software. In addition, the use of these functions must have no effect on the PLC scan time.

A device must be reconfigured automatically after replacement

The PLC must have serial links which support various types of communication: Modbus or open protocols.

### ➤ Standards and certifications

The PLC must conform to the main national and international standards covering electronic equipment for industrial control systems & FOLLOWING TYPE TEST REPORTS to be provided by the vendors

- CE marking according EN 61131-2
- Be compliant with IEC – 62443 standards
- Cyber Security Achilles Level 2 or equivalent.

Description of Type Test	Test Std.
<b>Electromagnetic Compatibility (EMC)</b>	
Electrostatic Discharge Immunity	IEC 61000-4-2
Radio-frequency, Electro Magnetic Field Immunity	IEC 61000-4-3
Surge Immunity	IEC 61000-4-5
Immunity to conducted disturbance by RF Field	IEC 61000-4-6

#### Environmental & Climatic Tests

Dry Heat	IEC 68-2-2
Cyclic Damp heat	IEC 68-2-30
Steady State Damp Heat	IEC 68-2-78
Change of Temp.	IEC 68-2-14

The system MUST be Achilles level 2 or equivalent certification for cyber security.

The system must be able to secure communication between PLC and engineering workstation / SCADA providing authentication and integrity of data

The internal firmware of the CPU must be digitally signed and encrypted

The integrity of the firmware must be checked before any application download and at start-up of the system

The integrity of the engineering software must be checked on demand

The system provides an access control list for each protocol and each connected IP address

Any modification of the operating mode of the system (Run / Stop / Program modifications) must be authenticated real time memory Integrity Control.

#### ➤ Environment

- Standards CSA C22.2 No 142, UL 1604, UL 508, Resistance to conducted disturbances, induced by radio frequency fields
- EN/IEC 61131-2: 2007
- Marine specification (LR, ABS, DNV, GL)
- 1 kV for Ethernet line conforming to EN/IEC 61000-4-4

### PLC – Specifications (At Main Control Room)

Sr. No.	Description	Specification
1	PLC Make	ANY INTERNATIONAL MAKE MEETS THE FOLLOWING REQUIRMENT & APPROVED IN UP JAL NIGAM (URBAN)
2	PLC Type	HOT Redundant PLC
3	Data Exchange	through high speed link of 1 Gbps
4	Operational Voltage	24V DC
5	Specification	Local indication using LED
6	CPU	16-bit Dual core processor
7	Programming Memory & Data Memory	32 MB ON board memory

8	Clock	Real time clock (RTC)
9	Communication	Serial (1 - RS 232, 1 - RS232/RS485) (GSM, GPRS, Data call, Satellite, Radio modem, serial, Ethernet)
10	Communication port	1 no RS 232/RS 485 1 Nos 10/100 base Ethernet port, 1 Nos USB Port
11	Ethernet Services	FTP Server, SNMP, DHCP Client, IEC VAR Access, Modbus TCP Server/Client
12	Web Services	Web Server
13	Operating temperature	-10 to 55 deg C.
14	Storage temperature	-40 to 70 deg C
15	Humidity	5- 95 % Non-condensing
16	Vibration	3 gn (vibration frequency: 8.4...150 Hz) on panel mounting
17	Shock Resistance	15gn for 11 ms
18	Operating Altitude	0 – 2000m

The hardware is a unique blend of rugged industrial I/O, real-time multi-tasking software and powerful communication capabilities. It shall be a locally intelligent unit having local memory and processor installed at a respective control and monitoring location in the water network; this can be a pumping station or a tube well station. The Redundant PLC hardware shall be programmable in SFC, IL, LD, ST & FBD.

**The high performance modular Redundant PLC must be designed to log all the pumping station parameters with time stamping in its NON-VOLATILE memory at the defined logging interval.**

The PLC shall be battery backed-up so as to maintain the parameters during power failure.

The PLC shall be designed to have communication compatibility for wireless mode viz. for GSM, GPRS, and Radio, satellite or wired mode viz. Telephone and serial to transmit data and receive commands remotely.

### **PLC SPECIFICATIONS FOR PUMPING STATION/PLANT**

Shall have following minimum specifications: -

1	Input/outputs	
2	Digital Input	24
3	Operational Voltage	24V DC
4	Specification	Local indication using LED
5	Analog Input ranges	0-10VDC, 0-5VDC, 4-20mA, 0-20 mA
6	Resolution	16 bits
7	Digital Output	16
8	Relay type	Relay/transistor Output
9	Operational Voltage	24V DC
10	Specification	Local indication using LED
11	CPU	16-bit Dual core processor
12	Programming Memory & Data Memory	Minimum required MB ON board memory

13	Clock	Real time clock (RTC)
14	Analog to digital converter	12/16-bit Resolution
15	Communication port	Dual LAN Ports 10/100/1000 MB Ethernet port 1 no Serial Port
16	Operating temperature	-10 to 55 deg C.
17	Storage temperature	-40 to 70 deg C
18	Humidity	5- 95 % Non-condensing
19	Vibration	3 gn (vibration frequency: 8.4...150 Hz) on panel mounting
20	Shock Resistance	15gn for 11 ms
21	Operating Altitude	0 – 2000m

- Should Support for communications protocols, including PROFINET, Modbus TCP/IP
- Advance cyber security with Achilles Level 2 certification

#### ➤ **IO Descriptions**

##### **Digital Inputs with following feature**

- \* Input voltage range 24 VDC, Input current (max): 7mA @ 24 VDC/ channel
- \* On off delay times: 1.6 ms
- \* Confirming to IFC 61131-2 type I
- \* Input impedance 4.7 kohm
- \* Response time 50 usec
- \* filtering time 1 usec
- \* Execution Time for 1 kinst. 0.7 msec and 0.3 for event and periodic

#### ➤ **Analog Inputs**

- \* Input Scan time: 500 ms Min.
- \* Input Type: 4-20 mA DC, 0-10 VDC.

#### ➤ **Analog Outputs**

- \* Output Type: PID Controlled.
- \* Output Level: 4-20 mA DC, 0-10 VDC

### **3:- TECHNICAL SPEC OF CLOUD APP. INTERFACE**

The online data shall be available for real time monitoring with the help of a cloud App supporting iOS/ Android or any other web browser like internet explorer. This data shall be encrypted for protection & up to 100 clients shall be able to log on simultaneously for one site.

### **4:- Technical specification for Soft Starter**

The soft- starter shall be developed and qualified in accordance with international standards, particularly with the standard dedicated to soft-starter EN / IEC 60947-4-2. The starter must be CE marked under the harmonized standard EN / IEC 60947-4-2.

#### ➤ **Description**

The operating principle of the Soft-starter should not simply take ground on a limitation of motor current during the transitional phases or on a voltage ramp but on a torque control motor. The Soft-starter should provide a torque ramp during the acceleration phase. Thus, it can control the torque during the starting period and if necessary provide a

motor torque constant throughout the acceleration phase. For pumping applications, the deceleration will be on torque a ramp.

- All Soft-starter sizes will have the same control board. That control board must be identical for all applications.
- All Soft-starters shall be equipped with means for measuring motor current to ensure protection.
- The measurements of the current will be active when the Soft-starter is by-passed (embedded by-pass for all sizes).
- The Soft-starter should have a separate power control.
- The terminals of the board control shall be of plug type for easy maintenance.
- Soft Starter should control 3-phase output with Programmable display.
- The Soft-starter will handle the by-pass itself: manage the closure of the by-pass at end of acceleration time and open that by-pass at end of stop sequence. That function must be compatible with the types of stop: freewheel, ramp
- The access to the settings can be locked by code. The monitoring parameters should remain accessible.

#### ➤ **Environment**

- The maximum relative humidity will be 95% without condensation or dripping water according to standards IEC60947-4-2.
- The storage temperature can be between -25 ° C to + 70 °

#### ➤ **Electrical characteristics of the Soft-starter**

- The Soft-starter will automatically adapt itself to the frequency of the mains 50 or 60 Hz with a tolerance of + / -10%.
- Outputs: The Soft-starter must have at least 2 relays with a NO/NC contact Maximum switching capacity on inductive load: 2 A at 250 Vac and 30 Vdc.

#### ➤ **Protections**

- The starter will include the management of Motor PTC probe.
- The starter will calculate continuously the motor overheating from the real current value (the current) must be measured and not estimated). Several classes of thermal protection will be proposed following the standard EN/IEC60947-4-2: Classes 10, 20, 30. The calculation of the thermal protection must be active even when the Soft-starter is not power energized.
- The starter shall be protected against thermal overload, over & under voltage.
- Dry run protection for pump motor.
- Protection against reverse-phase network, the loss of phases on mains or on motor.
- The protections will always be maintained even the Soft-starter is by-passed internal or self.

#### ➤ **Communication**

- The starter will include a multipoint serial link to be connected directly to a Modbus network. The starter shall be able to be connected to Ethernet and other networks and communication bus option.
- The communication shall provide access to the control, adjustment and monitoring of the Soft-starter.

#### ➤ **Display**

- The starter shall have a display and programming push buttons.
- The following information must be accessible on the display
  - Motor current (by phase)
  - Motor state
  - Current status (acceleration, deceleration, running).
  - Operating time.
  - The last fault occurred
  - Fault history
  - I/O status

## **5:- Technical Specification of Industrial Grade Display System for Local Control Room (L.C.S.) i.e. 65” Industrial Grade LCD Monitor**

### ➤ Qualification Requirements

- The OEM should be present in India with own manufacturing facility from minimum 5 years.
- The OEM should have service centers spread all over India.
- LCD display should be BIS approved

Group	Specification Item	Detailed Specification	Remarks
System	Display wall	PANELS OF 65" DIAGONAL IN A (1) X (1) CONFIGURATION COMPLETE WITH STANDARD WALL MOUNT	
	Display technology	Liquid Crystal Display	
	Display size and resolution	The diagonal size of each display unit/ module shall be 65" with a native resolution of at least 1920x1080 pixels	
	Light source	LED	
	Brightness	360 Cd/m2	
	Color	1.07 Billion	
	Response time	8ms	
	Viewing angle	H:178° V:178°	
	Contrast ratio	should be minimum 4000:1	
	Architecture	The control box and power supply should be in the same housing to ensure quick swapping of module for repair with minimum downtime	
Signal Interface	Input terminals	<ul style="list-style-type: none"> <li>• HDMI IN X1</li> <li>• DVI INX1</li> <li>• VGA IN X1</li> <li>• PC Audio –In X1</li> <li>• YPBPR IN(BNC)X1</li> <li>• AV INPUT X4</li> <li>• Audio IN (RCA)X1USBX2</li> <li>• Video Out BNC X1</li> <li>• Audio Out (RCA)X1</li> </ul>	
User controls	Power control:	1 AC power ON/OFF switch	
	Wire control:	RS232C/ RS422 input	
Electrical	AC power input range	100 V ~ 240 V, 50-60 Hz.	
	Power consumption	Normal operating should be <270 W	
	Life Time	50,000 hours	

## **6:-Technical specifications for Instruments and Cabling**

### **A)-Electromagnetic Type Flowmeter**

#### ➤ SPECIFICATIONS OF ELECTRO MAGNETIC FLOW METER

Electrical

Power Supply

: 24 VDC

Option	: 90 V AC to 265 V AC, 50/60 Hz
Power consumption	: 35 W (max.)
Output	: a) 4-20 mA Isolated (Max. Load 800 Ohms). b) 2 SPDT Relay. Programmable relay function Max. rating 2A at 230 Vac for non-inductive Load. c) Pulse output: 24 VDC Pulse Isolated (min. Load 150 Ohms) Option Frequency output of 0 to 1 KHz full scale
Accuracy	: $\pm$ 1% of flow rate
Repeatability	: $\pm$ 0.1 % of F.S.D
Time constant	: 0.8 to 8 seconds adjustable
Minimum conductivity	: 0.5 $\mu$ /cm (Micro Siemens/centimeter)
Input impedance	: 10 giga ohms
Full scale velocity	: 0.5 m/s to 10 m/s
Display	: 16 x 2 Alphanumeric LCD, in multiple -Engg. units
Data Entry	: 2 Hall Effect Switches
Flow data	: Bi-directional Flow with separate totalizers for forward and reverse flow : Empty Pipe Detection with Low Flow Cut off
Diagnostics	: Built in with Data retention in case of power failure. Password protection

### Enclosure

Housing material	: Cast Aluminum
Paint	: Polyurethane
Cable entry	: M 16 (3 No.) suitable for cable diameter from 4.5 mm to 10mm
Controller mounting	: Integral with sensor or Wall mounted
Ambient Temperature	: - 20 deg. C to + 60 deg. C
Protection	: IP 67for tubewell / IP 68 for OHT

### Sensor

Nominal Bore	: 10 NB to 600 NB
Meter Lining	: Rubber
Electrode Material	: SS 316
Metering pipe Flanges	: Low carbon steel, ASA 150 # flanges

Metering Pipe Material	: SS 304
Sensor Body Material	: Sheet Steel
Protection	: IP 68
Process Temperature	: + 80 deg. C
Process Pressure	: Up to Size 200 NB: 16 bars Sizes above 200 NB: 10 bar
Certification	: CE certified, RoHS from DNV & FM approval FM Certified

## **B) - Technical specification of Smart Pressure transmitter**

### **- Range as per site requirement**

✓ Working Principle	:	Micro - Capacitance Silicon sensor
✓ Type	:	Smart Microprocessor based, 2 wires
✓ Output	:	4 – 20 mA DC with Digital Communication (HART protocol)
✓ Power Supply	:	10.5 – 45 V DC
✓ Field Communication	:	Adjustment through push buttons on LCD” or Hand-Held HART Calibrator OR Remotely by PC Possible
✓ Span & Zero Adjustment:	:	Local & Remote
✓ Accuracy	:	0.065 % of calibrated Span
✓ Drift / Stability	:	±0.1 % of URL for 10 years
✓ Ambient Temp	:	- 40°C to 85°C
✓ Process Temp. Limits	:	- 40°C to 100°C
✓ Humidity	:	0 to 100 % RH
✓ Load Impedance	:	577 ohm at 24 V DC
✓ Diagnostic	:	Self indicating feature
✓ Supply voltage effect	:	Less Than 0.005% of calibration span per volts
✓ Temperature effect	:	Less than ± 0.05% of span per 100 C
✓ Zero Elevation & suppress	:	Anywhere within the range limits maintaining min allowable span
✓ Turn on time	:	Less Than 10 sec
✓ Damping	:	0.06 to 32 sec (configurable)
✓ Vibration effect	:	Better than ± 0.2 % of span per g at 200 Hz in any axis
✓ Response Time	:	Less Than 150 msec
✓ Over Range Pressure	:	Capable of withstanding over pressure up to 3 Times
✓ Update Time	:	Better than 50 msec
✓ Housing	:	Die cast aluminium alloy finished with polyester coating
✓ Protection class	:	IP 67
✓ Wetted Parts	:	SS 316
✓ Flange material	:	SS 316
✓ Diaphragm material	:	SS 316L
✓ Process Connection	:	G ½” male
✓ Electrical connection	:	½ NPT
✓ Mounting Brackets	:	Provided (SS)
✓ Turndown Ratio	:	100: 1

## **C)- Technical specification of sub soil water level transmitter for SUBMERSIBLE PUMP**

The “Hydrobar” series are submersible level transmitters with a cable to measure the level in water works, deep wells,

underground tanks, concrete bunkers, etc.

All transmitters are fully temperature compensated and are equipped with strong flush mounted diaphragms which are laser welded, this results in a perfect long-term stability.

Measuring ranges	: 0.1 bar to 10 bar
Output signal	: 4-20 mA, 2-wire
Adjustment	: Zero and span internally (not for FR type)
Overall accuracy	: 0,2% of adjusted span, temperature compensated
Power supply	: 13 to 40 V DC
Electrical connection	: M20 x1.5
External load (max.)	: 550 Ohm/24 V to 1400 Ohm/40 V DC
Protection grade	: IP68 (cable/SS tube) IP66 (electr. housing)
Process temperature	: -10°C to +70°C
Temperature sensitivity	: +/- 0,015%/K
Wetted parts	: AISI 316L (standard)
Material cable	: Polyethylene (PE)
Measuring sensor	: SS 316 with strong diaphragm for long life & long term stability (<0.1%/year)
Certification	: ISO 9001-2008, Bureau Veritas & DNV

#### **D) - Technical Specification of Radar Type Level Transmitter for OVER HEAD TANK**

A Radar type level transmitter is being specified for continuous monitoring of the water level at the LCS & MCS and for the logical operation of the pumps based on water level at the overhead tank/Bore well.

##### **➤ FUNCTIONAL/PHYSICAL**

Type: 6" horn configuration

Measurement: Pulse burst radar @ 26 GHz

Measured Variable: Level, determined by the time-of-flight of radar pulse reflections

Span: 15 inches to 40 feet (380 mm to 12.2 m) measured from threads

Output: 4 to 20 mA with HART: 3.8 mA to 20.5 mA useable (per NAMUR NE43)

Resolution: Analog 0.01 mA

Loop Resistance: 591 ohms @ 24 VDC and 22 mA

Diagnostic Alarm Selectable: 3.6 mA, 22 mA (**meets requirements of NAMUR NE 43**), or HOLD last output

Diagnostic Indication Meets requirements of NAMUR NE107

Damping Adjustable: 0-45

Keypad: 4-button menu-driven data entry

Display Display: 2-line 16-character display

Digital Communication HART Version 7—with Field Communicator, AMS, or FDT

DTM (PACT ware™), EDDL

Power (Measured at instrument terminals) HART: General Purpose (Weather proof)/Intrinsically Safe/Explosion-proof: 11 VDC minimum

Housing Material: IP67/die-cast aluminum A413 (<0.6% copper)

Cable Entry 1/2" NPT

SIL 1 Hardware (Safety Integrity Level):

Functional Safety to SIL 1 in accordance with IEC 61508

##### **➤ ENVIRONMENT**

Operating Temperature with LCD viewable: -20° to +70° C

Electromagnetic Compatibility Meets CE requirement Meets CE Requirements: EN 50081-2, EN 50082-2

Surge Protection: Meets CE Requirements: EN 61326 (1000 volts)  
 Shock/Vibration: ANSI/ISA-S71.03 Class SA1 (Shock); ANSI/ISA-S71.03 Class VC2 (Vibration)  
 Reference Conditions: Reflection from ideal reflector at +20° C  
 Linearity: ±0.3 inch (8 mm) or 0.1% of tank height (whichever is greater)  
 Measured Error ±0.3 inch (8 mm) or 0.1% of tank height (whichever is greater)  
 Resolution: 0.1 inch or 2.5mm  
 Repeatability: ±0.2 inch (5 mm) or 0.05% of tank height (whichever is greater)  
 Response Time: <2 seconds (configuration dependent)  
 Initialization Time :< 30 seconds  
 Ambient Temperature Effect: 0.05% per 10° C

### **E) - SMART Energy Meter**

Sr. No.	Description	Specification
1	Type	True RMS, Microcontroller based design, 2W 1□ □ 4W/3 □ 3W Balance & unbalanced operation
2	Accuracy class	1/ 0.5
3	Cut out size	92 x 92 mm Bezel: 96 x96 x mm
4	Suitable for	Multi parameter monitoring
5	Display	Seven Segment display
6	Casing	Compact 96 x 96 DIN enclosure
7	Key Pad	4 Functional keys to scroll through display pages for system values and programming parameter.
8	Auxiliary Supply	100-240V AC 50 Hz /110-240V DC
9	Voltage Input	Up to 480V (field configurable)
10	Current rating	5A or 1A AC (field configurable)
11	CT overload capacity	4000% of rating for 1 sec., 2000% for 4 sec., 120% continuous
12	Operating P.F.	ZERO LAG to UNITY to ZERO LEAD
13	Communication	RS 485 output port Standard MODBUS for all power parameters including harmonics. It should be possible to monitor real time vector chart using software.
14	Operating Temperature	0 to 55OC
15	Storage temperature	-200C to +700C
16	Humidity	90% RH, non-Condensing

### **F)-Actuator:**

***All Sluice valve along with initigral starter motorized Actuators as per “Schedule -G” shall be supplied by the Tenderer. The installation of Sluice valves with actuators is responsibility of the SCADA Vendor.***

- All the valves shall be operated by an electro mechanical actuator, comprising of motorized gear train and screw assembly which drives the valve stem. The actuator shall be supplied with the following accessories.
- Integral starter for starting of actuator
- 3 phases, 415 V, + 10%, 50 Hz. + 5%, A.C. squirrel cage induction motor.
- Reduction gear unit.
- Torque switch mechanism complete with set of torque switches.
- Limit switch mechanism complete with set of limit switches.
- Hand wheel for manual operation.
- Hand-auto changeover lever with suitable locking arrangement.

- Local control switch / push buttons.
- The actuator shall be suitable for operation in the climate conditions and power supply conditions given in the specification. The actuator shall be capable of producing not less than 1½ time the maximum required torque and shall be suitable for at least 15 minutes continuous operation.

➤ **Valve operational requirements:**

- The operation of valves must be sequential w.r.t the pump operation. As the pump starts, the valve shall start to open and reach 70% opening (identified by a limit switch) only after the complete pressure / full pump speed is reached, does the valve open 100%; the operation of this valve shall be based on time sequence w.r.t start time of respective pump.

➤ **Actuator Specifications**

Sr. No.	Description	Specification
1	Type	Three phase rotary / linear, multiturn /quarter turn
2	Enclosure	Standard/Flameproof version
3	Output speed	10-426 RPM
4	Output torque max.	30 MKG
5	Locking system	Self-locking
6	Drive kW/HP	0.75/1 to 2.2/3
7	Drive Speed	1500/3000
8	Maximum Axial Thrust Capacity	12000 kgs
9	Output shaft designs	As per DIN 3210
10	Mechanical stopper	Adjustable
11	Coupling to suit	Sluice valves, dampers
12	Gear reduction ratio	100:1 (max)
13	Type of gear box	Spur gear/worm gear
14	Supply Conditions	
	a. Rated voltage	415 V AC ± 10%
	b. Rated frequency	50 Hz ± 5%
	c. Combined variation	± 10%
	d. NO. of Phases	3 Phase (4 wire)
15	Reference Standards	I. S. 325, IEC34, VDE 0530, BS 2613
16	Type of motor	TEFC (Totally Enclosed Fan Cooled, Squirrel cage, induction.) / TESC (Totally Enclosed Surface Cooled) for IP 67 / 68
17	Drive Frame Size	80/90
18	Rotor Class	KL 60
19	Protection	IP 67 as per IS 13947 Part I 1993
20	Class of Insulation	Class 'F' with temperature rise restricted to class 'B'
21	Duty cycle	As per IS 325 - S1 continuous (S4 – Modulating as a special case) OR (S2 - 15 / 30 min as a special case.)
22	Method of starting	DOL - Direct on line with suitable actuator panel
23	Reference ambient temp	50° C
24	Motor paint	corrosion proof epoxy resin paint
25	Motor duty	S1 Duty motor suitable for
		3 Nos. of consecutive starts in hot condition

		8 Nos. of starts distributed over 15 minutes
26	Travel Switches	1 NO + 1 NC
27	Micro Switch	
	a. Torque Switches	1 NO + 1NC
	b. Travel / Torque Switches	2 NO + 2 NC

➤ **Isolation Transformer**

- Primary: 0-380V-440V-470V
- Secondary: 0-230V
- Capacity:300VA  
Insulation: 2.5 Kv
- Rated Temperature: 55 deg. C
- Frequency: 50 Hz, with required DIN rail mounted glass fuse type 4 sq. mm screw terminals and with extended bottom mounting angle; in output side to provide wago make push in type terminals 4 sq mm rating.

**G)-Uninterruptible Power Supply (UPS) with 45 minutes batteries backup on full load (as per site requirement)**

➤ **Technical Specifications**

Input	Nominal Voltage	200/208/220/230/240 Vac (single phase)	
	Voltage Range	100 ~ 300Vac (full load) *	
	Current Harmonic Distortion	<5%(full load)	
	Power Factor	>0.99(full load)	
	Frequency	40 ~ 70Hz	
	Electrical Connection	Terminal block	
Output	Voltage	200/208/220/230(default)/240 Vac (single phase)	
	Voltage Harmonic Distortion	≤ 2% (linear load)	
	Voltage Regulation	±1%(static); ± 2% (typical)	
	Frequency	50or60 ± 0.05Hz	
	Overload Capability	106 ~ 110%:10 minutes; 111~ 125%:5minutes;126 ~150%:30seconds	
	Electrical Connection	Terminal block	
Battery & Charger	Nominal Voltage	192VDC	240VDC
	Charger Current	Standard Charger (Built-in): 4A (adjustable) Extended Charger Internal: 4A (maximum) and External: In steps of 4A	
	Electrical Connection	Delta standard cable	

Display	LED		AC input, Battery, Bypass, Fault
	LCD(Multi-Language)		Input/Output/Bypass (voltage, frequency), Loading and battery level, Remaining runtime Abnormal message and intelligent self-diagnosis
Interface	Standard		RS232 x1, SNMP slotx1, Smart slot x1, Parallel portx1
	Management Peripherals	SNMPS lot	SNMP card, Mod bus card, Relay I/O control card, Enviro Probe, SNMP hub
		Smart Slot	Mini SNMP card, Mini Mod Bus card, Mini relay I/O control card, USB card, TVSS card
Conformance	Safety		CE, TUV, EN62040-1-1
	EMC		CISPR22 Class A, EN50091-2, IEC 61000
Others	Parallel Redundancy		1+1redundancy
	Remote Control		REPO (Remote Emergency Power Off); ROO (Remote On/Off)
	Common Installation	Battery	Feasible
	Optional Accessories		Rail kit; Maintenance bypass box; External battery pack; Internal charger board; External charger box; External charger board; Dust filter
Overall	Efficiency	Online Mode	92%(full load)
		ECO Mode	96%(full load)
	Temperature		0 ~ 40°C
	Relative Humidity		0 ~ 95%(non-condensing)
	Audible Noise		54d BA(atone meter)

### **H) Control panel with HMI & switch gear-**

- Control panel enclosure should be from CE/UL/TUV/CSA/LLOYDS REGISTER certified, Make- Rittal only
- Drawing and test report should be submitted with panels.
- MCCB should be at least 25KA capacities.
- Type 2 coordination should be followed
- Dimension shall be min 600mm (W)x1600mm(H)x500mm (D)
- Enclosure must be IP54
- Sealing gasket must be Neoprene (liquid foam must not be used)
- Mounting plate must be 3mm in thickness
- 1.5mm CRCA sheet, powder coated with Siemens grey shade, 2mm CRCA sheet door Mounting plate 2.5mm CRCA sheet
- Panel should be modular construction type on a frame which should be having 9-fold profile.
- Mounting plate should be adjustable & removable

- Bottom gland plate shall be in three parts
- Locking system must be three-point locking type

### ➤ HMI Specification

- Minimum 7" wide 800X480 Pixel LCD display with back-lit to display.
- In built Ethernet, USB miniport, USB type A for report generation, data logging, 485 Port embedded.
- 64000 colors
- Luminance :450cd/m<sup>2</sup>
- Real Time Clock
- Front panel: IP65
- Touch Screen
- Facility to connect printer directly
- Serial and parallel printing option
- Make: -Proface/Schneider/Allen Bradley/ABB/Fuji

## Technical Specification for SCADA at MCS

### Architecture

The SCADA architecture shall provide the following:

1. Client / Server architecture based on TCP/IP networking and report-by-exception (RBE) technology
2. Standalone single server operation.
3. Additional servers for client load sharing and remote locations.
4. Permanent Standby Server designed to be placed outside corporate firewalls providing a read-only access to the server while ensuring corporate security.
5. Fully automated data transfer between servers to provide complete server redundancy. This transfer shall include configuration, real-time data, historic data and event lists. Database updates shall be on an incremental basis with tuneable parameters
6. A scalable fully distributable architecture providing as per engineering station.
7. Where multiple servers are deployed, the system shall be capable of being configurable from a single client.
8. Forced changeover between main and standby allowing seamless changeover without shutting down.
9. Clients to connect to a synchronizing server as soon as the configuration and current data in the database has synchronized. Incomplete data sets as per clients request on event or trend provide indications that the synchronization is still in progress to ensure that conclusions are not drawn from incomplete data sets.
10. Configurable compression of data communications between client/server and server/server to allow optimisation of communications performance over WAN networks.
11. Change reporting on Client/Server and Server/Server links rather than polled communication to permit operation on WAN networks.
12. Capable of operating Client/Server and Server/Server links over low to medium speed channels depending upon database size.
13. Application shall be native 32-bit and 64-bit versions and supported on Windows® Server and Workstation operating systems including Windows 2000, Windows XP, Windows 2000 Server, Windows 2003 Server, Windows 7 (32 and 64 bit) and Windows Server 2008 R2 and later.

### Database

The SCADA database shall be of true database design and optimized for real-time SCADA operation. The database shall be object oriented and organized in a hierarchical structure.

Templates of Standard configuration shall support multiple object types including, but limited to:

- Point/ Tag objects

- PLC or RTU objects
- Mimics or Graphic display objects
- Trend objects
- Logic program
- Schedules
- Link objects

The SCADA database shall allow users to extend the database scheme to store custom data, in either the configuration or data stream. These changes can be performed online without need for server restart.

### **1. Operator Interface**

1. SCADA software shall provide the ability to support multiple local and remote display clients.
2. Display facilities shall be available via LAN, WAN and dial-up connection.
3. Rich Clients shall support database management and configuration changes.
4. Rich Clients shall support multiple monitors (multi-head display), allow logon for all heads from a single location. The system should also provide navigation facilities such that displays on each head can be controlled from any head. (yoking)
5. Integrated Web Sever capability shall be available, providing all display and operational facilities of the Rich Client without the need for additional software to be installed.
6. Web Clients shall allow users to view Mimics, Trends, Database Objects, Reports as well as perform control functions using a standard web browser.
7. Changes made to the SCADA server shall require no additional steps to be performed in order for those changes to be available to Rich Clients and Web Clients.
8. Rich Client shall be configurable to connect to one, or multiple server systems
9. Full function display clients shall automatically fail-over & reconnect to a redundant server node when server change-over occurs.
10. Look and feel shall be provided by the SCADA system operator interfaces, including provision for "favourites lists".

### **2. Mimics / Graphics**

SCADA system Mimics shall support a wide range of graphical facilities. Scalable Vector Graphics are required in order to permit operation of the SCADA system with different resolution clients operating simultaneously. Fixed resolution bitmap graphics are not acceptable.

Mimics shall be multi-layered, object oriented and permit mimics to be embedded in other mimics.

24-bit Colour shall be supported on mimics as standard.

Mimics shall support the ability to specify OPC data source information to display directly on the mimic. This permits data from other systems to be seamlessly integrated in to the SCADA display.

Objects embedded and displayed on any mimic shall be viewable through both the full function client and web client displays.

### **3. Start-up**

The SCADA system shall start-up unattended, and without compromising system security.

### **4. Configuration**

The SCADA software shall provide full seamless On-line configuration of all database parameters including but not limited to:

- Communication channels
- PLCs
- Points /Tags
- Scequences
- Schedules
- Alarm redirection
- Mimcs / Graphics
- Trends/ Graphs
- Reports

All aspects of the look and feel of the SCADA system, including default field values, shall be configurable. It is not acceptable for colour regimes, communication parameters and other aspects of the system to be hard-coded.

It shall be possible to add user defined fields to the SCADA database. These fields should be accessible both internally and externally to the SCADA system; being exposed via OPC, ODBC, OLE Automation, XML/SOAP, etc.

The SCADA server shall provide detailed diagnostics concerning its internal operation. The diagnostics

shall be available through capture to a log file as well as online locally on a server and remotely via Telnet and Web interface. Stored configuration records should be maintained in the historic database for a configurable time period, support redundant SCADA server configurations and allow access from standard database interfaces such as queries and simple mechanisms for displaying and filtering the configuration records.

#### **5. Alarm Management**

The alarm system shall provide facilities where actions can be triggered by alarms. These facilities shall be provided as a built-in integrated part of the system and include, but not be limited to the following :

- Configuration criteria for alarm actions
- Escalate Alarm priority
- Delivery of Alarm to user via SMS
- Delivery of Alarm to user via E-Mail
- Trigger other actions including sequences
- 

Where a full function Rich Client is connected to multiple SCADA systems, alarms from all systems shall be combined and filtered, based on user privilege and areas of responsibility.

Consequential alarms to allow one (or more) alarms to be suppressed as the result of another alarm occurring. Suppressed alarms will be received and processed by the SCADA Server and recorded in the event journal for future auditing, however the operator shall not be forced to take an action on an alarm where the cause is known.

#### **6. Event Journal**

The system shall provide, as a built in feature and without the requirement for custom or external software, facilities for event logging. These facilities shall be separate from the alarm list and include the capability to insert user comments at any place in the event list.

#### **7. Historical Data**

The SCADA system shall provide a built in data historian with the following facilities as standard features.

These shall be provided without the addition of external software modules:

- Time-series relational data base
- ODBC/SQL interface to historical (Trend ) data.
- Historical data to be stored with time stamp, point quality, Alarm status
- Historic storage is to be based on configurable criteria including time between samples, alarm state change
- Compression capability

#### **8. System Security & Access**

The SCADA system shall provide a high level of inherent security. To this end the SCADA software shall provide security access down to data point level, and support individual Users, User Groups and a matrix of system capability and access to any level of the SCADA database.

Full function Rich & Web client interfaces shall require explicit administrative configuration to valid Connection to the SCADA server.

The SCADA system security shall provide the ability to be integrated with Windows domains to Authenticate logon attempts against a trusted domain.

#### **9. Open Connectivity**

To provide easy access for customized reports and external data manipulation the SCADA software shall provide inherent OPC and ODBC database connectivity without the need for additional software options or modules. Integration with desktop Microsoft products is essential.

#### **10. Reports**

An integrated reporting package shall be able to generate, print and export reports:

- Triggered by SCADA events
  - On user demand
  - On time schedules Reports shall be able to be generated in a number of formats including:
    - HTML for viewing via Web interface
    - CSV format
    - M.S office® suite format
- Generated reports shall be able to be:
- E-mailed to assigned user

**11. Standard Drivers**

The SCADA system shall provide native support for fully integrated Wide Area SCADA PLC protocols. This shall include the capability for supporting all protocols in redundant SCADA server configurations and support redundant communication paths.

Apart from PLC and RTU communication drivers, the system shall also support as standard the following drivers:

- SMS (with TAP and UCP service) to mobile phones
- A full function system is required including calendar based rosters
- SNMP- monitoring of network devices such as routers, computers, UPS etc.
- NTP – time server monitoring and alarming
- ODBC – query data from other databases
- Windows Performance Monitoring
- OPC-DA driver

**12. Logic**

The SCADA system shall support logic sequences with full access to all SCADA system services at run time. Programming of sequences shall be to the IEC61131-3 international standard and support as a minimum the following languages:

- Ladder Diagrams (LD)
- Function Blocks (FB)
- Structured Text (ST)
- Sequential Function Charts (SFC)
- Special scripting languages to perform the control strategy will not be accepted.
- Cloud Based SCADA Not Acceptable.
- SCADA System Run Time should have flexibility to operate in English .
- Feasible to integrate video cameras to allow viewing of live video.

Capacity Description	Size
Number of SCADA I/O Device Subsystem servers	for 58 TUBELS
Number of SCADA Cluster servers for Trending, Alarm and Reporting	for 58 TUBELS
Number of SCADA Client Stations	for 58 TUBELS
Number of field devices	for 58 TUBELS
Physical I/O tags being read/written to field controllers	Unlimited and demonstrable to >1000000
Internal I/O tags within the SCADA networked system	Unlimited
Alarm tags	> 100000
Analog trend tags	> 20000
Average refresh time on a graphic display	< 1s
Average recall time for historical trend values	< 5s per day of data

**PLC Specifications for Control Station Processor**

- The processors must have an internal non-volatile memory to store application and data. Processor must also have a reserved slot for a removable cartridge so that the application and data backup can also be performed on mobile device.

- It must be possible to contact a PC (programming terminal) or a human – machine interface via a USB port integrated in the processor.
  - The range must provide processors with at least 3 built – in Ethernet ports featuring a web server compliant with various operating system: minimum is Windows, IOS, and android.
  - Embedded web server must provide CUP diagnostic, including **detailed information on Ethernet system networking.**
  - The Embedded web server must be customizable by the user to display application variables and advanced diagnostics features. Each processor should have a savable real – time clock which manages
    1. The current date and time
    2. The date and time of the last application shut-down. The date and time should be managed even when the processor is switched off for 20 days.
  - NTP server must be provided within the CPU.
  - The processors must be equipped with ground connection contacts without additional cabling.
  - The PLC must be able to load the program with the use of the memory cartridge.
  - Data Exchange through high speed link of 1 Gbps
  - Possible to add modules or add remote I/O islands in the configuration without interrupting the running process.
- The complete environmental footprint of the product must be known and all products must be designed witheco-design requirements (Green Premium)

- **Operating system**

The operating system (OS) must be capable of multitasking with up to 4 periodic tasks and more than 60 event or I/O tasks. Physical input can be program to prohibit any modification or downloading of the program.

Outputs can be set to fallback position when the PLC switches to STOP mode via channel by channel parameter entry.

Able to **set breakpoints and watchpoint** in application to check all system and data when executing application for debugging. System must also provide Step-by-Step running feature to execute all operations one by one in the application. Engineering tool must provide a trending tool embedded to display variables at a minimum of **1ms sampling rate**

- **Memory**

Application memory execution can be done on through embedded or removable memory.

**No battery supply is needed for non-volatile backup.**

The processor must provide up to 64 MB of integrated non-volatile memory as well as removable memory up to **4 GB**.

Feature to store the program, comments and symbols in the PLC. The "empty terminal" functionality must be possible whichever IEC language is used. It must be also possible to use the memory extension to back up files (production data, recipes, etc)

- **Communication**

The Ethernet connection must support SNMP agent functions for the standard MIB II base (RFC 1213).

Synchronized and unsynchronized drops with PLC scan can be **managed over standard and open Ethernet communication.**

Must provide exchanges of variables:

- Explicit exchanges (via function blocks integrated in the application)
  - Implicit exchanges (Using cyclical variables generated by the single declaration of the device)
    - Dedicated function blocks should be available.
- The PLC must be accessible via Ethernet (from a remote site) using a standard Internet browser or any other platform (android, iOS). These functions must not require any prior configuration or special software. In addition, the use of these functions must have no effect on the PLC scan time.
- Variables or animated objects in the Internet browser's web pages must be refreshed automatically from the PLC using a standard Internet protocol, without having to update the entire page.
- A device must be reconfigured automatically after replacement
- The PLC must have serial links which support various types of communication: Modbus or open protocols.

### **Standards and certifications**

The PLC must conform to the main national and international standards covering electronic equipment for industrial control systems:

- CE marking according EN 61131-2
- Be compliant with IEC – 62443 standard

- **Cyber Security**

The system MUST be Achilles level 2 certified

The system must be able to secure communication between PLC and engineering workstation / SCADA providing authentication and integrity of data

The internal firmware of the CPU must be digitally signed and encrypted

The integrity of the firmware must be checked before any application download and at start-up of the system

The integrity of the engineering software must be checked on demand

The system provides an access control list for each protocol and each connected IP address

Any modification of the operating mode of the system (Run / Stop / Program modifications) must be authenticated real time memory Integrity Control.

### **PLC – SPECIFICATIONS**

<b>Sr. No.</b>	<b>Description</b>	<b>Specification</b>
1	PLC Make	Rockwell / ABB/L&T/Schneider /Cimcon/Omron/ GE IP
2	Input/outputs	
3	Digital Input	24
	Operational Voltage	24V DC
	Specification	Local indication using LED
	Analog Input ranges	0-10VDC, 0-5VDC, 4-20mA, 0-20 mA
	Resolution	16 bit
	Digital Output	16
	Relay type	Relay/transistor Output
	Operational Voltage	24V DC
	Specification	Local indication using LED
4	CPU	16 bit Dual core processor
5	Programming Memory & Data Memory	64 MB on board memory with optional memory card
6	Clock	Real time clock (RTC)
7	Analog to digital converter	12/16 bit Resolution
8	Communication	Serial (1 - RS 232, 1 - RS232/RS485) (GSM, GPRS, Data call, Satellite, Radio modem, serial, Ethernet)
9	Communication port	1 nos RS 232/RS 485 1 Nos 10/100 base Ethernet port, 1 Nos USB Port
10	Ethernet Services	FTP Server, SNMP, DHCP Client, IEC VAR Access, Modbus TCP Server/Client
11	Web Services	Web Server
12	Operating temperature	-10 to 55 deg C.
13	Storage temperature	-40 to 70 deg C
14	Humidity	5- 95 % Non condensing
15	Vibration	3 gn (vibration frequency: 8.4...150 Hz) on panel mounting
16	Shock Resistance	15gn for 11 ms
17	Operating Altitude	0 – 2000m

The hardware is a unique blend of rugged industrial I/O, real-time multi-tasking software and powerful communication capabilities. It shall be a locally intelligent unit having local memory and processor installed at a respective control and monitoring location in the water network; this can be a pumping station or a tube well station. The Redundant PLC hardware shall be programmable in SFC, IL, LD, ST & FBD.

**The high performance modular Redundant PLC must be designed to log all the pumping station parameters with time stamping in its NON-VOLATILE memory at the defined logging interval.**

The PLC shall be battery backed-up so as to maintain the parameters during power failure.

The PLC shall be designed to have communication compatibility for wireless mode viz. for GSM, GPRS, Radio, satellite or wired mode viz. Telephone and serial to transmit data and receive commands remotely.

Following shall be the other minimum design features of the PLC for pumping plant:

- 16-bit or higher bual core processor based CPU
- Data memory of 8 MB and program memory of 64 MB
- Having option of data storage <= 32 GB
- 3 Nos. of communication port
- RTC
- Timers and counters sufficient as required.
- While the design of the offered PLC Hardware shall be as per the site design on case- to - case basis, te offer PLC shall have full expandability.
- Surge withstand 1 KV for transistor output in common mode conforming to EN/IEC 61000-4-5

**Environment**

- Standards CSA C22.2 No 142, UL 1604, UL 508, Resistance to conducted disturbances, induced by radio frequency fields
- EN/IEC 61131-2 : 2007
- Marine specification (LR, ABS, DNV, GL)
- 1 kV for Ethernet line conforming to EN/IEC 61000-4-4

**Digital Inputs with following feature**

- \* Input voltage range 24 VDC, Input current (max): 7mA @ 24 VDC/ channel
- \* On off delat times: 1.6 ms
- \* Confirming to IFC 61131-2 type I
- \* Input impedence 4.7 kohm
- \* Response time 50 usec
- \* filtering time 1 usec
- \* Execution Time for 1 kinst. 0.7 msec and 0.3 for event and periodic

**Analog Inputs with**

- \* Input Amplification: 1M Ohm for voltage & 50 Ohm for current input
- \* Maximum allowed overload 13V DC & 40 mA.

**Soft Starter Specification**

- 1.1 The soft- starter shall be developed and qualified in accordance with international standards, particularly with the standard dedicated to soft-starter EN / IEC 60947-4-2. The starter must be CE marked under the harmonized standard EN / IEC 60947-4-2. Make ABB/L&T/Siemens/ Schneider/Jayshree Electron/Unique).

**Description**

2.1 The operating principle of the Soft-starter should not simply take ground on a limitation of motor current during the transitional phases or on a voltage ramp but on a torque control motor. The Soft-starter should provide a torque ramp during the acceleration phase. Thus, it can control the torque during the starting period and if necessary provide a motor torque constant throughout the acceleration phase. For pumping applications, the deceleration will be on torque a ramp.

2.2 All Soft-starter sizes will have the same control board. That control board must be identical for all applications.

2.3 All Soft-starters shall be equipped with means for measuring motor current to ensure protection.

2.4 The measurements of the current will be active when the Soft-starter is by-passed (embedded by-pass for all sizes).

2.5 The Soft-starter should have a separate power control.

2.6 The terminals of the board control shall be of plug type for easy maintenance.

2.7 Soft Starter should control 3-phase output with Programmable display.

2.8 The Soft-starter will handle the by-pass itself: manage the closure of the by-pass at end of acceleration time and open that by-pass at end of stop sequence. That function must be compatible with the types of stop: freewheel, ramp

2.9 The access to the settings can be locked by code. The monitoring parameters should remain accessible.

#### **Environment**

3.1 The maximum relative humidity will be 95% without condensation or dripping water according to standards IEC60947-4-2.

3.2 The storage temperature can be between -25 ° C to + 70 °

#### **Electrical characteristics of the Soft-starter**

4.1 The Soft-starter will automatically adapt itself to the frequency of the mains 50 or 60 Hz with a tolerance of + / -10%.

4.2 Outputs: the Soft-starter must have at least 2 relays with a NO/NC contact Maximum switching capacity on inductive load: 2 A at 250 Vac and 30 Vdc.

#### **Protections**

5.1 The starter will include the management of Motor PTC probe.

5.2 The starter will calculate continuously the motor overheating from the real current value (the current must be measured and not estimated). Several classes of thermal protection will be proposed following the standard EN/IEC60947-4-2: Classes 10, 20, 30. The calculation of the thermal protection must be active even when the Soft-starter is not power energized.

5.3 The starter shall be protected against thermal overload.

5.4 Dry run protection for pump motor.

5.5 Protection against reverse-phase network, the loss of phases on mains or on motor.

5.6 The protections will always be maintained even the Soft-starter is by-passed internal or self.

#### **Communication**

6.1 The starter will include a multipoint serial link to be connected directly to a Modbus network. The starter shall be able to be connected to Ethernet and other networks and communication bus option.

6.2 The communication shall provide access to the control, adjustment and monitoring of the Soft-starter.

#### **Display**

7.1 The starter shall have a display and programming push buttons.

7.2 The following information must be accessible on the display

- Motor current (by phase)
- Motor state
- Current status (acceleration, deceleration, Running).
- Operating time.
- The last fault occurred
- Fault history
- I/O status

### **General Specification of LARGE Video wall- Laser Type for Master control Room (M.C.S)**

1. The Indian Manufacturing unit should be certified for the following quality management System ISO9001:2008,ISO14001:2004 and BS OSAS 18001:2007
2. The cubes, controllers and the associated software should be from the same manufacturer to ensure seamless integration.
3. The product should be BIS Approved.
4. **Matrix required – 2X1 for MCS**

The system is required to display the HMI Screen to the operator .The system shall be complete with display wall with 50" Diagonal Laser based Rear projection system as per site requirement. Each cube should have minimum specification as below:

#### **Cube:**

1. Cube & controller: should be from the same manufacturer.
2. Resolution :1920x 1080 resolution of chip
3. Light Source type:Nichia Laser light source, Individual cube should be equipped with at least 3 laser banks and each laser bank should have minimum 8 diodes.
4. Light Source Redundancy-System should be able to illuminate all the laser banks at the same time ,system should not be Blank( No image ) screen due to failure of any diode in any laser bank
5. Brightness :Minimum 2000 lumens
6. Control-IP based control to be provided
7. Remote-IR remote control should also be provided for quick access

8. Brightness Uniformity:  $\geq 95\%$  and control should be IP based and IR remote control should also be provided for quick access.
9. Contrast Ratio: Min 1800:1 or better
10. Screen to screen gap:  $\leq 0.2$  mm
11. Screen should have an anti reflective glass backing to prevent bulging.
12. It should have Control BD I/P terminals –1X-Digital DVI ,1X-HDMI,1X-Analog Dsub-15, 1X-Analog RGBHV
13. Cooling: Inside cube should be by means of a heat pipe only .Pump based cooling involving hazardous liquids is not acceptable .
14. Source redundancy: System should be able to switch to HDMI input if primary DVI input is not available and system should also automatically switch back to primary DVI input from HDMI input as soon as the primary DVI input is available again.
15. Auto Colour Adjustment Function: Provide auto colour adjustment function with sensor based and should have the facility to be switched on or off as per user requirement.
16. Maintenance Access: Rear.
17. Cube Size: Each cube should not be less or more than 50" diagonal size.

### **Video Wall Controller**

1. Controller: Controller to control Video wall in a matrix (1 x 2) outputs, inputs along with software's
2. Chassis: 19" Rack mount
3. Processor : Single Quad Core Intel® Core™ i7 Quad Core 3.4 GHz processor) or better and supports 64-bit Operating System Windows 7 with RAM capacity of 16 GB or more with HDD 500 GB or more
4. Net Working: Dual Port Gigabit Ethernet.
5. Power Supply: 1+1(Redundant Hot Swappable).
6. Cooling: Advanced proven cooling mechanism.
7. Input/Out Put Support: DVI/HDMI/USB/ LAN/ VGA/SATA port.
8. Accessories: DVD +RW, Keyboard and mouse.
9. Voltage: 100-240V @ 50/60 Hz.
10. Redundancy Support: Power Supply, HDD, LAN port & Controller.
11. Scalability: Display multiple source windows in any size, anywhere on the wall.
12. Control Functions: Brightness /contrast / saturation/ Hue/ Filtering/ Crop / rotate.
13. Formats: DVI /RGB/Component and NTSC/ PAL/SECAM
14. Operating temperature: 10°C to 40°C , 80 % humidity

### **Video Wall Management**

1. Display and Scaling: Display multiple sources anywhere on display up to any size.
2. Input Management: All input sources can be displayed on the video wall in freely resizable and movable windows and should save and load desktop layouts from Local or remote machines.
3. Layout management: It should support all Layouts from Video, RGB, DVI, Internet Explorer, Desktop and Remote Desktop Application and Multiple view of portions or regions of Desktop, Multiple Application can view from single desktop.
4. Other Features: Remote Control over LAN, Remote management, alarm management& multiple concurrent clients.
5. Cable Management: Cube Health Monitoring, Pop-Up Alert Service and graphical User Interface.
6. It should be able to provide an error message in three sections a) Problem area b) Error Module Location c) Error Module image.
7. Should be able to control & monitor individual cube, multiple cubes and multiple video walls.
8. Provide video wall status including Source , light source ,temperature, fan and power information
9. Should provide a virtual remote on the screen to control the video wall
10. Input sources can be scheduled in " daily", "periodically" or "sequentially" mode per user convenience
11. System should have a quick monitor area to access critical functions of the video wall.
12. User should be able to add or delete critical functions from quick monitor area.
13. Automatically launch alerts, warnings, error popup windows in case there is an error in the system.

### **Energy meter**

<b>Sr. No.</b>	<b>Description</b>	<b>Specification</b>
1	Type	True RMS Microcontroller based design, 2W 1ϕ ϕ 4W/3 ϕ 3W Balance & unbalanced operation
2	Accuracy class	1/ 0.5

3	Cut out size	92 x 92 mm Bezel: 96 x96 x mm
4	Suitable for	Multi parameter monitoring
5	Display	Seven Segment display
6	Casing	Compact 96 x 96 DIN enclosure
7	Key Pad	4 Functional keys to scroll through display pages for system values and programming parameter.
8	Auxiliary Supply	100-240V AC 50 Hz /110-240V DC
9	Voltage Input	Up to 480V (field configurable)
10	Current rating	5A or 1A AC (field configurable)
11	CT overload capacity	4000% of rating for 1 sec., 2000% for 4 sec., 120% continuous
12	Operating P.F.	ZERO LAG to UNITY to ZERO LEAD
13	Communication	RS 485 output port Standard MODBUS for all power parameters including harmonics. It should be possible to monitor real time vector chart using software.
14	Operating Temperature	0 to 55OC
15	Storage temperature	-200C to +700C
16	Humidity	90% RH, non Condensing

**Actuator:**

***All gate valve along with motorized Actuators as per "Schedule -G" shall be supplied by the tenderer. The installation of gate valves with actuators is responsibility of the SCADA Vendor.***

- All the valves shall be operated by an electro mechanical actuator, comprising of motorized gear train and screw assembly which drives the valve stem. The actuator shall be supplied with the following accessories.
- 3 phase, 415 V, + 10%, 50 Hz. + 5%, A.C. squirrel cage induction motor.
- Reduction gear unit.
- Torque switch mechanism complete with set of torque switches.
- Limit switch mechanism complete with set of limit switches.
- Hand wheel for manual operation.
- Hand-auto changeover lever with suitable locking arrangement.
- Local control switch / push buttons.
- The actuator shall be suitable for operation in the climate conditions and power supply conditions given in the specification. The actuator shall be capable of producing not less than 1½ time the maximum required torque and shall be suitable for at least 15 minutes continuous operation.

**Valve operational requirements:**

- The operation of valves must be sequential w.r.t the pump operation. As the pump starts, the valve shall start to open and reach 70% opening (identified by a limit switch) only after the complete pressure / full pump speed is reached, does the valve open 100%; the operation of this valve shall be based on time sequence w.r.t start time of respective pump.

**Actuator Specifications**

Sr. No.	Description	Specification
1	Type	Three phase rotary / multiturn, quarter turn and Linear including positioning card and torque switch
2	Enclosure	Standard/Flameproof version
3	Output speed	10-426 RPM

4	Output torque max.	30 MKG
5	Locking system	Self locking/ Non – self locking
6	Drive kW/HP	0.75/1 to 2.2/3
7	Drive Speed	1500/3000
8	Maximum Axial Thrust Capacity	12000 kgs
9	Output shaft designs	As per DIN 3210
10	Mechanical stopper	Adjustable
11	Coupling to suit	Butterfly valves, dampers
12	Gear reduction ratio	100:1 (max)
13	Type of gear box	Spur gear/worm gear
14	Supply Conditions	
	a. Rated voltage	415 VAC $\pm$ 10%
	b. Rated frequency	50 Hz $\pm$ 5%
	c. Combined variation	$\pm$ 10%
	d. NO. of Phases	3 Phase (4 wire)
15	Reference Standards	I. S. 325, IEC34, VDE 0530, BS 2613
16	Type of motor	TEFC (Totally Enclosed Fan Cooled, Squirrel cage, induction.) / TESC (Totally Enclosed Surface Cooled) for IP 67 / 68
17	Drive Frame Size	80/90
18	Rotor Class	KL 60
19	Protection	IP 65 as per IS 13947 Part I 1993
20	Class of Insulation	Class 'F' with temperature rise restricted to class 'B'
21	Duty cycle	As per IS 325 - S1 continuous (S4 – Modulating as a special case) OR (S2 - 15 / 30 min as a special case.)
22	Method of starting	DOL - Direct on line with suitable actuator panel
23	Reference ambient temp	50° C
24	Motor paint	corrosion proof epoxy resin paint
25	Motor duty	S1 Duty motor suitable for
		3 Nos. of consecutive starts in hot condition
		8 Nos. of starts distributed over 15 minutes
26	Travel Switches	1 NO + 1 NC
27	Micro Switch	
	a. Torque Switches	1 NO + 1NC
	b. Travel / Torque Switches	2 NO + 2 NC

### Actuator Panels

- wall mounting type
- non compartmentalized
- dust and vermin proof, IP 54 protection
- 16 SWG CRCA sheet, powder coated with Siemens grey shade
- 415 V , 50 Hz
- size 400mm(W) x 550 mm(H) x 200 mm (D)
- single door, bottom gland plate, earthing terminal

### ISOLATION TRANSFORMER

- Primary: 0-380V-440V-470V
- Secondary: 0-230V
- Capacity: 300 VA
- Insulation: 2.5 Kv
- Rated Temperature: 55 deg. C
- Frequency: 50 Hz , with required DIN rail mounted glass fuse type 4 sq. mm screw terminals and with extended bottom mounting angle; in output side to provide wago make push in type terminals 4 sq mm rating.

### LIST OF IMPORTANT INDIAN STANDARDS

### **(FOR MECHANICAL AND ELECTRICAL ENGINEERING WORKS)**

The following list includes the various Indian Standards which are only IMPORTANT and are very commonly referred to and used for the works included in this tender. These Standards are to be strictly adhered to unless otherwise is applicable in the relevant context. These standards are to be followed both in respect of material and execution.

Mechanical and electrical engineering works included in the tenders.

This list is not exhaustive but contains only the standards that are very frequently used. If a standard exists for a particular item of material or equipment or code of practice the same shall be followed whether the same is included in the list, specification other parts of the tender documents or not. Some Indian Standards are referred to in the specification/drawing other parts of the tender documents and they are supplementing this list if they do not find a place in the list.

- 4771 - Abrasion resistance iron castings.
- 3849 - Grey Iron Castings(Part-I)
- 1526 - Pressure pipe for water, gas and sewage centrifugally cast(spun) iron
- 1538 - Pressure pipe for water, gas and sewage cast iron fittings.
- 780 - Sluice Valve for water works purposes (50 to 300mm size)
- 2906 - Sluice Valve for water works purposes (300mm to 1200mm size)
- 5312 - Swing check type Reflux valve for water works purpose.
- 226 - Structural Steel
- 2062 - Weldable structural steel.
- 616 - Use of metal are welding for general construction in mild steel code of practice
- 1810 - Requirement for well screens & slotted pipe.
- 1710 - Pump-vertical turbine mixed and axial flow for clear cold water.
- 4270 - Seamless or electrical welded pipes.
- 23 - Manual meter are welding of mild steel, code of practice
- 030 - Carbon steel casting for general purposes.
- 875 - Carbon steel billets, slabs and bars for forgings.
- 409 - Calibrated load chain for pulley blocks and other appliances.
- 2429 - Round steel shore link chains(electric butt welded)
- 3042 - Single faced sluice gate.
- 3443 - Chain rail sections
- SP30 - National electrical code
- 4237 - General requirement of switch gear and control gear for voltage not exceeding 1000V.A.C or 1200V.D.C.
- 10118 - Code of practice for installation and maintenance of switch gear.
- 4047 - Heavy Duty air-break switches and composite units of air break Switches and fuses for voltage not exceeding 1000V.
- 8828 - Miniature air break circuit-breaks for A.C.Voltage not exceeding 1000V
- 2208 - HRC cartridge fuses.
- 3043 - Code of practice for earthing.
- 4691 - Degrees of protection provided by enclosures for rotating electrical machinery.
- 4889 - Method of determination of efficiency of electrical machines.
- 4722 - Rotating electrical Machines.
- 4029 - Guide for testing 3phse induction motors.
- 4729 - Rotating electrical machines, vibration of measurement and evaluation of
- 9046 - A.C. Contractors.
- 375 - Marking and arrangement for switch gears busbars, main connection and auxiliary wiring.

## **I: -Technical Specification of Desktop / PC FOR LCS**

**Processor:** 10th Generation Intel® Core™ i7-6500 processor (6MB Cache, up to 4.20 GHz)

### **Common Specs**

**Operating System:** Windows 10 Professional 64bit English

**Monitor:** 32" LED

**Memory:** 4GB, DDR4, 2133MHz

**Hard Drive:** 1TB 7200 rpm Hard Drive

**Video Card:** Intel® HD Graphics 510 with shared graphics memory (for i3 Desktop)  
Intel® HD Graphics 530 with shared graphics memory (for i5 Desktop)

**Optical Drive:** Tray load DVD Drive (Reads and Writes to DVD/CD)

Data transfer rates up to 3,600 KB/s (CD read/write)

Data transfer rates up to 10,800 KB/s (DVD read/write)

### **Ports & Slots**

1. Power on button
2. Audio in & Audio Out Jack
3. (2) USB 3.0 ports,
4. Tray Load Optical drive
5. Air vent
6. Line in/out and microphone port
7. VGA port
8. DVI port
9. (4) USB 2.0 ports
10. Expansion card slots
11. Power supply unit
12. Network port

**Wireless:** 802.11n + Bluetooth 4.0, M.2, 1x1

### **Networking**

Interface: M.2

Transmission standards: 802.11 b/g/n

Single band: 2.4 GHz

LAN: 1000BASE-T

Technology: Realtek RTL8161

Data transfer speeds: up to 10/100/1000 Mb/s

Transmission standards: 1000BASE-T Ethernet

**Power:** 65W External Power Adapter, 180W Internal PSU

## **Technical specification of Modular Control Desk for LCS-**

Bidder should refer the control desk design for any clarification of items.

Bidder should submit the below certificates / documents at the time of BID submission for Console Manufacturer, in light of absence of the documents BID can be rejected.

- a) ANSI / BIFMA Certificate for Consoles
- b) ISO 9001 & ISO 14001 Certificates
- c) Green Guard GOLD Certificate for low emissions

### **➤ Structure**

Console System must be of modular design. The Console design shall address the functional, ergonomic and aesthetic requirements of the particular working environment while complying with accepted human factor design and ergonomic standards for viewing distance, angle, keyboard height, and knee space requirements.

- Standard top height of modular control desk shall be 750 mm. The Console Table Top / Working Surface should be made of 25mm MDF Board with 1mm Laminate to be wrapped around the Table top. Drawing is enclosed.
- Size of modular control desks shall be as per seating capacity of 2 Persons and 4 persons and it should have arrangement for placing their workstations below the desk on the Bottom Tray of the Control Desk.
- The Basic Structure should consist of Extruded AL Profiles (6063T6 grade) binded by Top & Bottom (min 2mm) MS Frames formed in such a way as to provide maximum buckling and torsion resistance. The Front & Back Panels should be openable / removable (with Push Lock Mechanism) made of laminated MDF Board in min thickness of 18mm. The Side Panels should be fixed type, made in 26mm MDF Board Claded on 18mm MDF Board. All panels must be attached to the frame with concealed fasteners. Console access panels (Front & Rear Panels) must be removable without the use of tools. The Front panel should be positioned in such a way that there should be sufficient leg space (min of 400mm from the front edge of the Table Top).
- All sheet metal / aluminum parts must be finished with electrostatic powder coating with average of min 80 microns over all surfaces.
- The console frame shall have provisions for leveler legs to be incorporated into the frame.

#### ➤ **Work Surface**

The Console Table Top should be made of 25mm MDF Board with wrapped around Laminate, with no sharp Edges. The work surface platform shall have smooth edges and transitions, thus avoiding sharp corners or potential rib catchers for operator safety.

#### ➤ **Modular Rear Wall (Slat Wall)**

- Wall should be of min 86 mm (Height) and approx. 200-300 mm high from the Monitor Base.
- Modular walls shall be made of 2mm thick Extruded Aluminum (6063T6 aluminum alloy).
- It should have high Load bearing capacity. Minimum weight carrying capacity has to be 20 KGs per Meter.

#### ➤ **Monitor Arms**

- It shall be capable for mounting all type of existing LCD monitor with dimensions between 17" to 27" using suitable adopter/additional base plate, if required any.
- Vendor shall provide the suitable adopter/additional base plate for mounting the existing LCD monitors.
- It shall allow the rotate/ tilt/ raise/the monitors as well as fix their adjustment.
- The monitor arm should be Articulating monitor arm

#### ➤ **Miscellaneous: -**

- There shall be a closed cabinet below the modular control desk for placing of CPU. Cabinet should have proper cooling system. CPU needs to be accessible from front as well as rear side of control desk for easy working and maintenance.
- The cabinet shutters shall be of Butt Hinged type with 18mm thick MDF.
- Rear shutters of each console should have provision of Airflow opening for cooling and heat dissipation effect.
- Rear panel shall have ventilation fans mounted on it.

- It shall have proper arrangement for flow of cables i.e. LAN Cable, Power cable, VGA cable, Mouse cable, Keyboard etc.
- Design of control desk shall allow cables from the floor cable channel.
- Control desk shall be equipped with individual power distribution unit (PDU) (06 no for one Modular Control Desk) and capable of being switched on/off individually. Power supply socket should be dual type i.e. Universal type.
- All bolts must be of SS material to avoid rust due to environment.

RESPECTIVE VIEW OF CONTROL DESK WITH 2 WORKS -STATION FOR VIDEO WALL CUBES (MCS) OR LCD MONITORS (LCS) ARE

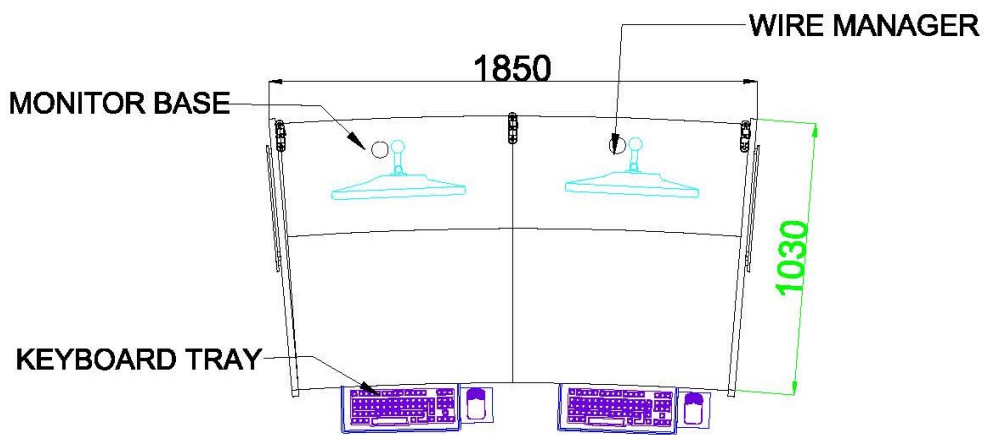

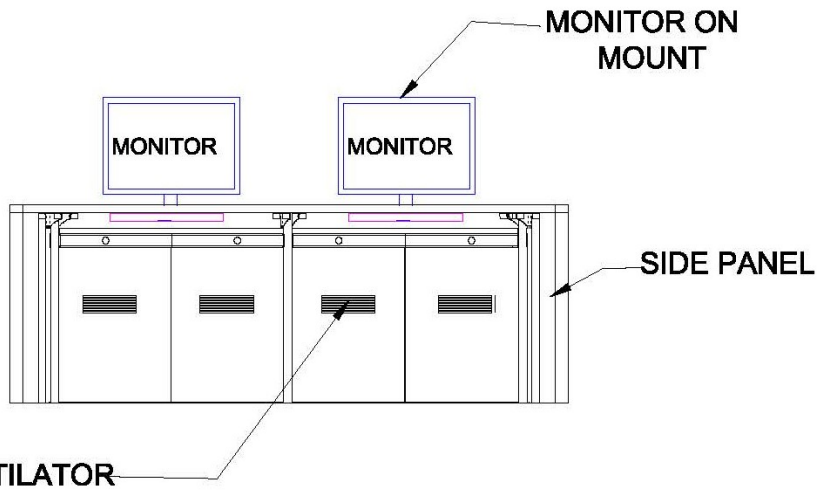

**MONITOR WALL AS PER SITE REQUIRED MATRIX OPTION-1**

H x W x D = 750mm X 6400mm X 600mm

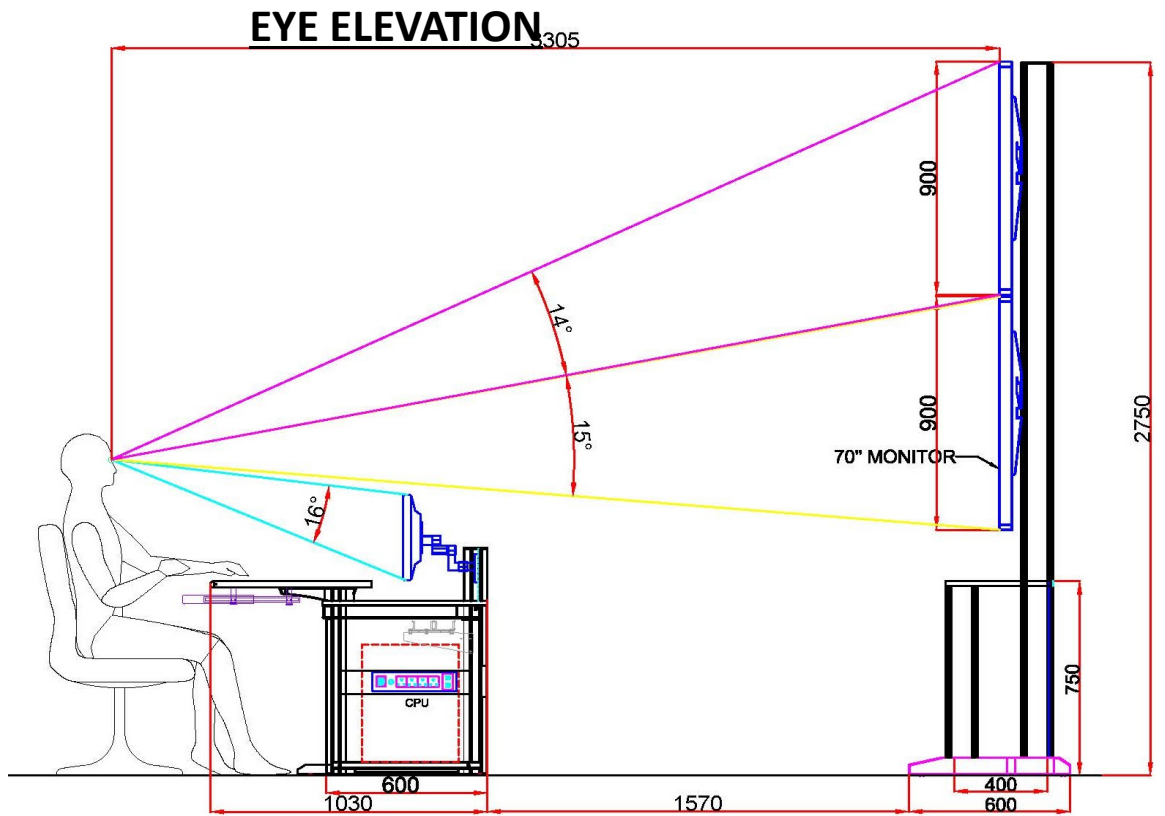

**MONITOR WALL AS PER SITE REQUIRED MATRIX**

H x W x D = 750mm X 6400mm X 600mm

### **Construction**

- a) Extruded AL Profile structure with MS (2mm) Top & Bottom Frame.
- b) Laminated 18mm ( $\pm 1$ mm) MDF Board Side Panels (Fixed Side Panels) & Laminated 18mm ( $\pm 1$ mm) MDF Board Based Front & Back Modesty (Removable Front & Back Modesty through Lock).
- c) Table Top in Laminated 18mm ( $\pm 1$ mm) MDF Board.
- d) Both Horizontal & Vertical Managers - For routing Lan & Power Cables within the desk.
- e) Power Distribution Sockets - within the desk for Powering of Active Devices.
- f) Adequate space for CPUs & Other equipment placed with in the desk.

#### **➤ Work Station Chairs**



- Medium back rest ergonomically designed revolving chairs.
- The chair should have a hydraulic gas for seat height adjustment.
- Adjustable PU Arms
- The seat and back Net Tapestry
- The chair base should be of nylon material

### **J: - Cable**

- Following types of cables shall be supplied, laid and terminated as per instructions provided.
- Copper 1.5Sq.mm control cables from REMOTE TERMINAL UNIT panel to field sensors.
- Control cables for Aux. Supply to transducers
- GSM/GPRS cable between MCS/REMOTE TERMINAL UNIT and modems
- Any other cables required for the job.
- Control cables shall be of 1100 Volts grade, Tinned annealed electrolytic solid copper conductor, PVC insulated, extruded PVC inner sheathed, and overall PVC sheathed conforming to IS1554-I/1988.
- Communication cable if used anywhere shall be twisted pair multi-core 1.0 Sq mm, Braided & Aluminum Foil Shielded & Screened as per Belden standards.

## **INSTALLATION SPECIFICATIONS (General)**

### **➤ Cable Installation Specifications**

- The contractor shall follow all the ISI rules & regulations.
- Cable shall generally be installed interchange and buried in ground except for some short run in trays below the floor. Cables are laid on tray and risers shall be neatly dressed and clamped at an interval of 1500mm and 900mm for horizontal and vertical cable runs.
- The clearance between electrical power & data cables must be maintained 6" min. throughout the route.
- The crossing of electrical power & STP cable shall be at 90° only.
- The shield of cable must not be removed up to cable entry to I/O.
- The twist of cable must be maintained up to final termination.
- The insulation twist shield shall not be damaged while pulling the cable.
- The termination and connection of cables shall be done strictly in accordance with drawing and/or directed by the Engineer. The work shall include all clamping, glanding, fitting, fixing, tapping, crimping and grounding as required.
- The vendor shall perform all drilling, cutting on the gland plate and any other modification required and plugging the extra holes. The vendor shall provide on control cable cores at all terminations. Termination and connections shall be carried out in such a manner as to avoid strain on the terminals.
- The vendor shall supply the required cable glands of suitable type and size. Cable glands shall be of heavy duty, tinned brass, and single/double compression type complete with necessary armor, clamp and tapered washer etc. Cable gland shall match with the size of different control cables. They shall provide stand leak proof terminations.
- The vendor shall make every effort to minimize wastage during erection work. In any case, the wastage shall not exceed 2.5% for total quantity of cable supplied.

### **➤ General Installation**

- The transducers shall be mounted on Bakelite sheet of suitable size and then they shall be mounted in the panels.
- Phasing out NO/NC contacts in panels for breaker auxiliary switch for on/off indications, along with necessary wiring.
- Phasing out of spare NO/NC contacts in panels for "Auto Trip" indication with necessary wiring.
- Installation, earthing, testing and commissioning of REMOTE TERMINAL UNIT panel along with necessary wiring for above mentioned points.
- Supplying, installation, testing and commissioning of hardware, peripherals etc.
- Supplying, installation, testing, customization of software's.
- Submission of cable schedules, wiring schedules, test reports, final "ASBUILT" drawings etc.
- Handing over the system as a whole after becoming fully operational to the Enigma.
- Although it may not be specified here, but all other work required for successful installation, testing and commissioning shall be in vendor's scope.

### **➤ Installation of instruments**

- Electro magnetic Flowmeters if asked for shall be installed according to the recommended practices to ensure full bore arrangement; installation shall be carried out with all necessary fittings and fixtures by piping vendor; supply, testing and performance guarantee of the flowmeter to CUSTOMER shall be a part of the contract of SCADA Vendor; the installation which shall be kept under the scope of piping vendor, shall in any case be carried out under the supervision of SCADA vendor.
- Instruments like Level transmitter shall be installed by SCADA Vendor, only according to accepted standards and specifications.
- Valves shall be provided by CUSTOMER where as required and shall be installed and in operating condition; SCADA Vendor shall install their Actuators suitably selected to operate the valves according to the logic desired by client.
- Necessary loop power supply for operation of instruments like Valve etc shall be provided by CUSTOMER.

## **ADDITIONAL TECHNICAL SPECIFICATIONS-**

### **Miscellaneous Field Equipment:**

#### **• Instrumentation Cables:**

- I. Cables for 24 V DC signals & 4-20mA DC signals: 660V/1100V annealed, tinned, high conductivity 1.0sq. mm stranded copper conductor, extruded PVC insulated two/three cores twisted in to pair/trade, laid up collectively, individual pair/ trade shielded and overall shielded with

aluminum Mylar tape, ATC drain wire run continuously in contact with aluminum side of the tape, inner sheathed with extruded PVC, armored with galvanized steel wire, overall sheathed with extruded FRLSPVC conforming to IS1554, BS:5308 & IEC:189 Part-II.

- II. Cables for 230 V AC/110V DC signals: 660V/1100V grade multi core cables, multi stranded high conductivity annealed 1.5sq.mm. stranded tinned copper conductor, extruded PVC insulated, inner sheathed with extruded PVC, armored with galvanized steel wire, overall sheathed with extruded FRLS PVC conforming to IS1554, BS:5308& IEC:189 PartII.

#### **Cabinets for Field Instruments:**

- I. It shall be fabricated from cold rolled steel with powder coating sheet of minimum 2mmthick and shall be suitable for wall mounting or pedestal mounting as required.
- II. The cabinet shall be properly painted from inside by white paint and from outside by paintshadeRAL7032.
- III. The cabinet shall conform toIP-54 protection and shall have built-in locking facility.
- IV. The cabinet shall be earthed properly. A steel plate/pipe, as per the requirement, shall be provided in the cabinet for mounting the instrument and accessories.

#### **Mounting:**

- I. All equipment on front of panel shall be mounted flush or semi flush. In case of semi-flush mounting, only flange or bezel shall be visible from the front. Equipment shall be mounted such that removal and replacement can be accomplished individually without interruption of service to adjacent equipment. Equipment mounted inside the panel shall be so located that terminals and adjacent devices are readily accessible without the use of special tools. Terminal markings shall be clearly visible.
- II. Cut-out sand wiring for free issue items, if any, shall be according to corresponding equipment manufacturer's drawing. Cut-outs, if any, provided for future mounting of equipment shall be properly blanked-off. Wherever required, panels shall be matched with other panels in the control room in respect of dimensions, colour, appearance and arrangement of equipment on the front.

#### **Earthing for Instruments:**

The panel shall be equipped with an instruments earth bus securely fixed along the inside base of panel. All metallic cases of relays, instruments and other panel mounted equipment and cable shields, shall be connected to the instrument earth bus. Looping of earth connections which would result in loss of earth connection to other devices when the loop is broken shall not be permitted. However, looping of earth connections between equipment to create alternative paths to earth bus shall be provided. A separate instrumentation earth bar mounted on insulating supports (a 'clean' earth) shall be provided with in the panels. Instrumentation and control cable screens shall be connected to this earth. Earth for instruments shall be separate from electrical station earth.

#### **Frame Earthing:**

All metal parts other than those forming part of an electrical circuit shall be connected to a copper earth bar run along the inside bottom of the panel. The minimum section of the earth bar shall be 25mmx3mm. Connection of the earth bar to the station earth shall be carried out by Contractor.

#### **Space Heater:**

Space heaters of adequate capacity shall be provided inside control panels to prevent moisture condensation on the wiring and panel mounted equipment when the panel is not in operation. The heaters shall operate on 230/110VAC. Heaters inside the panels shall not be mounted close to the wiring or any panel mounted equipment. The operation of heaters shall be controlled by thermostats.

#### **Interior Lighting and Receptacles:**

- I. Each panel shall be provided with either a fluorescent or filament lighting fixture rated for 230V, 1phase, 50Hz supply for the interior illumination of the panel during maintenance. The illumination lamp shall be operated by door switch as well as manual switch. Each panel shall be provided with 230V,1phase,50Hz, combined 5amps and15amps, 3pin receptacles with a switch and neon indicating. The receptacle with switch shall be mounted inside the panel at a convenient location.
- II. Voltage Level and Power Supply Units Voltage levels for control schemes and power supply for instruments shall be limited to regulated 24VDC.

#### **Labels:**

All the equipment mounted on the front facia of control panel as well as equipment mounted inside the panels shall be provided with individual labels with equipment designation engraved. The labels shall be mounted directly below the respective equipment. Also, the panel shall be provided at the top with a label engraved with panel designation.

- I. Switches and Miniature Circuit Breakers (MCBs): Each control panel shall be provided with necessary arrangement for receiving, distributing, isolating and protecting of DC and AC supplies for various control, signaling, lighting and space heater circuits. The incoming and sub-circuits shall be separately provided with Miniature Circuit Breakers (MCBs). Potential circuits for relaying and metering also shall be protected by MCBs.

#### **Terminal Blocks:**

Terminal blocks shall be 660Vgrade, 20amps rated, one-piece molded, complete with stud type terminals, washers, nuts and lock nuts and identification markings. Terminal block design shall include a white fiber marking strip with clear plastic, hinged terminal covers. Markings on the terminal strips shall correspond to wire numbers on the wiring diagrams. All spare contacts and terminals of the panel mounted equipment and

devices shall be wired to terminal blocks. There shall be a minimum clearance of 250 mm between the first row of terminal blocks and the associated cable gland plate. Also, the clearance between two rows of terminal blocks shall be a minimum 250mm. Panel internal wiring shall not be looped directly from instrument to instrument. The same shall be looped through the panel terminal block only. If accidental short circuiting of certain wires is likely to result in malfunction of equipment, such as closing or tripping of a breaker or positive and negative wires, these wires shall not be terminated on adjacent terminal blocks.

### **Cable Supports**

All external cables shall present a neat appearance and shall be suitably braced, placed in toughing clipped or laced to prevent effects of vibration.

### **Terminal Identification**

Every terminal and test plug shall be uniquely identified within the terminal cabinet by means of a terminal number. Appropriate labels shall be used to permit quick and unambiguous identification of each terminal and test plug.

### **Painting of Control Panel:**

All sheet steel work shall be phosphate in accordance with the following procedure:

Oil, grease, dirt and swarf shall be thoroughly removed by emulsion cleaning. Rust and scale shall be removed by trickling with clean water followed by final rinsing with diluted ichromate solution. The control panel shall be powder coated with thickness of coating of minimum 60 microns shall be provided. QA test certificate shall be furnished for thickness adhesion and hardening of powder coating.

Service: For Automatic operation and monitoring of pumps

- Type: Freestanding
- Construction: Prefabricated and modular construction
- Sheet Material: Cold rolled sheet steel
- Sheet thickness: 2mm for all the sides, 3mm for gland and mounting plate
- Internal Lighting: Required
- Cable Entry: Bottom
- Access: Front and Rear
- External Colour of the panel: RAL 7032
- Internal colour of the panel: Glossy white/RAL7032

### **Inspection and Testing Requirements**

- To ensure that a well-engineered and contractually compliant system is delivered by the Contractor, the following tests shall be performed.
  - a) Site Acceptance Test(SAT).
  - b) Site Acceptance Tests(SAT): Site Acceptance Testing activities shall include the following:
    - Pre-Commissioning/Commissioning checks and tests for Instrumentation Systems
    - The Contractor shall carry out the pre-commissioning /commissioning checks and tests listed below and submit the report of the same to Engineer's Representative. The pre-commissioning /commissioning checks listed below are indicative and the Contractor shall prepare and submit for approval by the Engineer's Representative the pre-commissioning /commissioning program proposed by him. If during the pre-commissioning /commissioning checks and tests it is found that a instrument needs re-calibration then the instrument shall be re-calibrated by the Contractor at no extra cost to the purchaser and the test reports of there-calibration shall be submitted to the Engineer's Representative for approval/record.

## **SPECIAL CONDITIONS OF CONTRACT FOR OPERATION & MAINTENANCE PERIOD OF 5 YEARS (AS PER REQUIREMENT)**

1. The activities proposed for O & M proposed are as follows:

Operation & Maintenance of Automation and SCADA system for 5 years. This will include operation & maintenance of all software, hardware, sensors, analyzers, monitors, electrical equipment & wiring, actuators, flow meters, pressure sensors, energy meters, automated chlorinators etc. installed or repaired under this contract.

- Operation, Maintenance, Manage, Repairs of the water supply system (instrumentation and SCADA system as per BOQ) and Monitoring and Service Delivery Period during the contract period
- O & M of monitoring & control of Water network from Main Scada room

- Responsible for providing Qualitative water supply to the connected facilities and maintaining the SCADA related infrastructure.
- Day to Day Operation & Maintenance of the system as per BOQ. Any issue other than BOQ will be handle by department.
- Programming of PLC/RTU, repairs & calibration of instruments as and when needed.
- Operation & Maintenance of portable download devices as required.
- Weekly data to department on demand.
- Operation & Maintenance of the online calibration validation equipment
- Planned Preventive Maintenance of Instruments & PLC Panels and other accessories on monthly basis.
- Remote monitoring setup by technology as per BOQ.
- Training & awareness by presentations, meetings, etc once every year.
- Intensive maintenance training at site shall be given. Contractor shall arrange minimum 2 training programs per year to benefit its employee and the staff on good engineering practices and development in water supply and O&M.
- The primary objective of this project is real time remote monitoring & operation of proposed water supply to up to distribution network of site on parameters like Flow, Pressure, Levels, Energy Consumption, Motor and Pumps control over existing infrastructure.
- The objectives of this initiative are following:
  - Timely availability of real time operating parameters.
  - Real time assessment of water supply.
  - Reliable real time data for service level parameters
  - To provide alert & alarm in case of deviation to set parameters
  - To use latest technology effectively and efficiently to yield significant improvements in efficiency, productivity, profitability and competitive advantage to Society.
  - To enable better decision making by providing real time data and a technological platform for effective integration with other communications and information management technology
  - To provide significant opportunities for item-based process improvement and innovation in the functioning of Water network

Current project is aimed at

- Real time Dashboard view of Overall system on healthiness Efficient utilization of water.
- Ease of coordination for maintenance activities from the source to the consumers-end.
- SCADA would enable Centralized control and monitoring of distribution and collection system which would in turn provide data for water modelling and energy use optimization, as well as predictive maintenance of distributed equipment. The central control room which would be established for automation of water Distribution ensures constant communication from the server to the remote units. The system will have configuration to support fail safe design for round the clock monitoring

## **2. MONTHLY & ANNUAL REPORTS AND MEETINGS**

### **2.1 MONTHLY & ANNUAL REPORTS**

Monthly production reports shall be prepared by the tenderer and submitted to the Department in three copies. The first monthly report shall cover the period up to the end of the first calendar month following the commencement date. There after every monthly report shall be submitted in the prescribed format within 7 days after the last day of the month to which it relates. Reporting shall continue until the contractor has completed all work, which is known to be outstanding at the completion date.

Each Report shall include the following but shall not be limited to:

- (1) Daily water flow meter reading at pumping stations, along with KWH meter reading at pumping stations at scheduled time in formats prescribed by engineer in- charge.
- (2) Monthly return of total production of the month & power consumed, power breaks down report, reason for low production etc.
- (3) Annual reports in the prescribed format
  - Review of the last months work production figures & program for next month's production
  - Payment issues if any
  - Disputes if any

- Any other issues deemed necessary.

## **2.2 MONTHLY MEETINGS:**

Monthly meeting shall be held in the office EE jal nigam as mutually fixed in advance. The proposed agenda for the meetings shall be exchanged at least 1 week in advance. It is required that a decision maker of the Contractor is present at the meetings so that binding decisions can be taken about outstanding issues. Generally, the following issues shall be discussed.

## **3. RIGHT OF ACCESS TO THE SITE DURING EXECUTION**

The UPJN shall give the contractor right of access to all parts of the site. The site for execution of the work will be made available as soon as the work is awarded. In case, it is not possible for the UPJN to make the entire site available on the award of the work, the Bidder shall arrange his working.

program accordingly. No claim, whatsoever, for not giving the site in full on award of the work or for giving the site gradually in parts will be tenable.

However, if and to the extent that the UPJN's failure was caused by any error or delay by the contractor, including an error in, or delay in the submission of, any of the contractor's documents, the contractor shall not be entitled to such extension of time.

The contractor shall be responsible for the adequacy, stability and the safety of all site operations, of all methods of construction and of all the works.

**Procurement of spares for O&M :** For the pumping stations which awarded for O&M Contractor shall normally procure the genuine spares from the original manufacturer/sole distributor/authorized dealer of the make/equipment which is being replaced. Prior approval shall be obtained from UPJN in case of procurement from any other source.

## **4. THE SAFETY PROCEDURES**

Adequate safety precautions against fire, flooding, lightening, electrical shocks and accident due to moving/ non moving heavy equipment's shall be strictly observed by the contractor at his own cost. Suitable safety measures like boots, gloves, insulated tools, alarms, Chequered rubber sheets etc. shall be provided by the contractor at his own cost. A fully equipped necessary medical first aid box should be available at pump house at all time. In absence of observance of above safety precautions, the contractor shall be responsible for any unforeseen loss of the equipment or persons dealing with these equipment's.

The contractor shall

- Comply with all applicable safety regulations.
- Take care for the safety of all persons entitled to be on the site.
- Make reasonable efforts to keep the site and the work clear of unnecessary obstruction so as to avoid danger to the persons deployed on O&M.

## **5. UN-FORESEENABLE DIFFICULTIES:**

- The contractor shall be deemed to have obtained all necessary information as to risk, contingencies and other circumstances which may influence or affect the works.
- By signing the contract, the contractor accepts the total responsibility for having ascertained all difficulties and costs of successfully completing the works and
- The contract price shall not be adjusted to take account of any unforeseen difficulties or costs.

**6. RIGHTS OF WAY AND FACILITIES** The contractor shall bear all costs and charges for special and/or temporary rights of Way, which he may require, including those for access to the site. The contractor shall also obtain, at risk and costs, any additional facilities outside the site which he may require further purposes of the works.

However, the contractor shall be provided the site and all pump house campus to undertake the work of repair / renovation / rehabilitation.

## **7. SECURITY OF THE SITE**

Unless otherwise stated in particulars conditions:

- The contractor shall be responsible for keeping unauthorized persons off the site, offices, campus etc. within the scope of works.

- Providing adequate manpower for the security of the material brought to the site for which payment has been made to the contractor.

## **8. RULES AND REGULATIONS APPLICABLE ON STAFF ENGAGED BY CONTRACTOR**

Staff engaged for entire operation/ maintenance etc. shall have to be in accordance with the rules and regulation laid down by the Ministry of Labour Welfare, Govt. of India, The wages and other essential amenities, group insurance, compensation etc. shall be paid as per Government rules and all expenditure on this account shall be contractor's responsibility. The necessary registration under rules shall be mandatory.

The compensation due to loss of lives/ retrenchment etc. shall be borne by the contractor. The Department shall not bear any liability of the labours, as it is the entire responsibility of the contractor. He will be employer under labour/ factory act 1948 etc. and UPJN is only concerned with O&M through this contract.

The contractor is liable for engaging sufficient skilled staff for proper O&M of all machinery and pumping station as directed by Engineer in-charge.

### **SITE BOOKS**

For the purpose of quick communication between the Engineer in Charge and the Contractor, site books shall be maintained at all sites, where work is being carried out, so as to be readily available. Any instructions or order which the Engineer in Charge may like to issue to the Contractor may be recorded by him in the site book and two copies thereof taken by him for his record.

## **9. TESTING OF PUMPS, FLOW METERS, ENERGY METERS ETC.**

The contractor shall submit test certification from the manufacturer for all new flow meter brought by him before installation at Pumping Stations and Tube Wells of design duty condition. inspection/ testing charges for all Equipment(s) and material(s) if required for the work, the arrangement for inspection/testing and expenses thereto shall be borne by the contractor. All sorts of tools & plants required for operation and maintenance of the project shall be arranged by the contractor at his own cost. The UPJN will not provide any T&P. No extra payment will be allowed to contractor on this account. Contractor has to arrange all T & P required for O & M at his own cost and no claim on this account will be entertained.

1. In the event of any damage/loss of life and property during the O&M of the project, the contractor shall be solely responsible and liable for compensation and damages.
2. In the event of strike by the operation and maintenance staff employed by the contractor the UPJN shall be empowered to operate and maintain and pumping stations at the sole risk and cost of the contractor.
3. The contractor shall be responsible for any breakdown and appropriate amount will be recovered from his bill if the breakdown happened due to negligence of the contractor's staff. If breakdown is not attended within 12 hours for tube wells and

2 Hours for the pumps Houses, appropriate amount

4. i.e. @ Rs. 1000/- per hour per occasion will be recovered from his bill.

5. Contractor is responsible to maintain at least 90% of the desired flow in all the Zones, in event of contractor failing to maintain production with 90% of desired production in any zone, due to non-operation of pumps or pumping system he shall be penalized @ Rs.1000 per day per zone. In case if the production is less than 75% of desired flow for a particular day than a penalty of Rs. 2000 per day will be imposed for a particular zone. If contractor fails to maintain production less than 50% of desired flow than a penalty of Rs. 5000/Day will be imposed. If the contractor fails to produce 75% flow of desired flow for a consecutive three days, he shall be penalized Rs. 5000/Day additionally.

The period of non-availability of power at the sources shall be accounted for proportionately for comparison against the base line production in different zone during these days when power failure has occurred. Contractor will not be responsible if water is not available from water sources, or if there is failure in pipe lines or CWR/OHSR, Rising mains etc.

6. Contractor has to carry out minor civil repair of pumping stations, building etc. as directed by Engineer in charge for which no extra payment shall be made. It also includes white washing, colour washing and painting of pump house, CWR etc. twice during the contract period first after completion of one year of the contract period and second after completion of fifth year.

7. Lighting inside and outside the pump houses shall be maintained by the contractor. The faulty tube lights & HPSV lamps or lighting fixtures/LED shall be repaired/ replaced by the contractor at his own cost. Failing to do the same, a compensation amounting to Rs. 100/- per day per site or as deemed suitable by Engineer in charge would be charged from the contractor.

8. Spares requirement for maintenance of pumping system including electrical installation at each pumping station should be kept normally in the stock. However, if found not available in stock then contractor shall have to arrange it immediately. Whenever any pump machinery or electrical accessories goes out of order the stock maintained by the contractor shall be accessible to the Engineer in charge all the time for inspection.

9. In case of sudden break down Engineer In-charge will decide whether the break down or losses is attributable to contractor's poor preventive maintenance or not. If break down is found on the part of contractor then suitable cost of repair/ breakdown /losses shall be recovered from his due payments. If not rectified / replaced the losses shall be recovered from his due payments.

## **10. Records of repair and spares consumed**

### **10.1 Machinery History Sheet Register**

Contractor shall maintain a register of History Sheet of all machinery at pumping station. Contractor shall enter periodical checking, preventative maintenance, break down maintenance, material consumed, old material received back for vertical turbine pump sets, energy efficient pump sets, switch gear. Contractor shall also enter total break -down hours of pump sets before any preventive or running maintenance of centrifugal pump sets/mono blocks. History sheet register shall be get verified by representative of Engineer in charge in a month.

### **10.2 Inspection Register**

The contractor shall maintain an inspection register at Pumping Station. Contractor should produce the register whenever UPJN visit the head works. Compliance with date and time shall have to be recorded.

### **10.3 Register for Recording Maintenance Work at Pumping Station**

The contractor shall maintain a register at pumping station showing details of work done at pumping station, other than preventive and maintenance. The contractor shall also enter the material consumed for that work.

***All the pumping sets installed at pumping station shall be operated as per the schedule prescribed by Engineer-In-charge and as per the availability of the electrical power at adequate voltage. The engineer in charge, may also pre fix time schedule of 'start & stop' of any of the pumping set according to the demand of water or to facilitate repair & maintenance of the pipelines or to preventive maintenance.***

10. Maintenance of electromagnetic flow meter and bulk water meter will be done by the contractor which includes all type of repair, replacement and calibration. If power meter installed by UPJN goes out of order due to any electrical fault, it will be replaced by the UPJN for which no charges will be recovered from the contractor. But if the sub energy meters installed by contractor go out of order, then same shall be repaired/ replaced by the contractor at his own cost.

11. The Electromagnetic flow meter supplied by the contractor must be of the make approved attached in RFP. Supplied meter must be as per the technical specification provided in "Technical Specification" section of this document.

12. In event of water meter going out of order, the water production / transmission during such period shall be taken on the average water production/ transmission during the previous seven days based on the quantity of water produced/ transmitted per KWH of energy consumed.

13. In case, it is not possible to take reading (s) of water meter(s) or energy meter (s) on particular day(s), due to unavoidable circumstances the reading (s) taken on subsequent day shall be used to calculate the water production and energy consumption during this period, Production of water and energy consumption at pumping station of this project during such day (s) when taking reading (s) was not possible shall be calculated on proportionate basic.

14. If doubt is raised by any of the parties, in reference to the correctness of the bulk water meter, an ultra sonic flow meter or the master meter shall be installed in series and the reading of the meter under question shall be compared with other available flow meter which has been calibrated earlier with working meters (the calibrated ultra-sonic meter or master meter shall be arranged by the contractor). If the difference is within  $\pm 4\%$ , no change of meter will be done. If it is beyond this limit, the meter shall be replaced within 24 hours by the contractor.

**15.** Essential spare parts & electrical components, (panels etc) to be kept as standby arrangement by the contractor to ensure minimum break down period in case the electrical equipment or pump installed at any of the pumping stations going out of order.

**16.** If the contractor fails to provide the minimum personnel responsible for O&M of the facility as defined in scope of work, the amount payable for each month may be reduced proportionately to the schedule of deployment of personnel proposed by the contractor or as per the actual expenditure incurred by the Department to fulfill

the duties and liabilities of the contractor under this contract, whichever is more, at discretion.

**17.** In event of break down, resulting in suspension of supplies the contractor shall take such action as may be reasonable and necessary at his cost and expenses, to prevent, avoid, or mitigate injury damage and/or loss as soon as possible and rectify the defects/repair the facilities at his own cost, so as to commence the supplies at the earliest possible. The contractor must report all such incidents, indicating the cause and contractor's response thereto,

**18.** The contractor shall utilize its personnel and all his resources to take such action as may be reasonable and necessary in the event of a break down. The contractor must incur all expenditure and take all measures, which are necessary (in accordance with good industrial practice) in case of break down, effecting the facilities and/or to safeguard lives or property.

**19.** The UPJN shall be entitled to terminate this contract on account of any or the following reasons attributable to the contractor, unless arising as a result of a force majeure event, or any cause related to the obligations of the UPJN. **a** Not maintaining the desired quantities of flow (discharge) at pumping station of this scheme in continuous period and/ or for a continuous period of more than 15 days.

**b** Repudiation of this contract by the Contractor or the evidencing of an intention by the contractor not to be bound by the terms of this contract.

**c** Appointment of a provisional liquidator in providing for winding up of the contract unless such appointment has been set aside within 45 days.

**d** The contract is ordered to be wound up by a court or files a petition for voluntary winding up except for the purpose of amalgamation or reconstitution provided that such amalgamation or reconstitution does not adversely affect the ability of the amalgamated or reconstituted entry to perform its obligations under this contract, the successor has assumed in writing unconditional responsibility for the performance of the contractor's obligations and the technical, financial and operating capability of the successor is satisfactory to the UPJN

**e** The contractor abandons the operation of the facility.

**f** Under conditions expressly mentioned in any Clause of this conditions of contract for operation and Maintenance.

**g** In case of illegal connections and law and order situations not attributed to the contractor activity all necessary support shall be extended by the Government to the contractor and their workers

## **SCOPE OF WORK FOR O & M OF PUMPING STATIONS, TUBE WELLS & OVER HEAD TANKS**

**2.2** The scope of work for operation and maintenance of Various Pump Houses, Tube Wells & Over Head Tanks as list attached in this RFP is on turn - key job and shall basically comprise of the following but not limited to:

- (a) A Tripartite agreement shall be formed between Contractor, BSCL & U.P.Jal Nigam for the operation and maintenance period of 5 years before Signing of bond .
- (b) Operation and maintenance (including preventive & periodical maintenance) of all Items installed, Tube Wells as stated above.
- (c) The contractor shall be responsible for operation and maintenance of all the materials under the project.
- (d) The contractor have to carry out routine check up and preventive/ periodical maintenance of all the equipment/ machinery as per schedule in RFP document, all the routine check- up & periodical/preventive maintenance of equipment/ machinery shall be undertaken as per manufacturers manual/ instructions and standard Engineering practice.

### **2.3 Arrangement of Spares**

The contractor shall procure the spares for plant & machinery and to maintain an inventory of spares for likely requirement. Any spares required/ directed by Engineer in-charge shall have to be kept in stock.

#### **2.4 Damages to U.P. Jal Nigam Equipment**

Normally there should not be any break down. However if break down is found to happen because of damaged/ burning of any part of equipment then same shall have to be replaced/ repaired by the contractor at his cost without any loss of time.

#### **2.5 Replacement of equipment and their parts Any**

Any part of equipment is found necessary to be replaced during the preventive maintenance, which in the opinion of contractor may result break down, shall be replaced immediately under intimation in writing to the Engineer in-charge. The cost of such part/ equipment shall be borne by the contractor.

#### **2.6 Period of Running Pump House in a Day**

The pump sets in the pumping station are to be operated for 24 hours a day or as per direction of engineer in charge. The contractor shall have to keep his operating staff round the clock in three shifts so that pumping can be done round the clock. Contractor shall also be responsible for safety & security arrangements of all MEI equipment's at the pumping stations.

#### **2.7 Up keeping of log Books and Records:**

The following records shall be maintained and produced periodically by the contractor for proper monitoring by Engineer in-charge (As per performa to be decided by the UPJN)

- (a) Daily Log book showing pressure, discharge, voltage, current, temperature of rewinding, temperature of bearing of motors, level in CWR, interruption of power if any, hourly PF (to be recorded on basis of U.P. Jal Nigam meter) etc.
- (b) History sheets of overhauling / maintenance/ replacement electrical/ mechanical equipments, which will be duly verified by the in-charge of pumping station. 2.8 Inspection/ Observation register will be maintained at each pumping station by the contractor. Instruction recorded in the register shall be complied immediately under the direction of Engineer in charge & compliance shall be recorded in the books.
- 

The observations in the log book should be recorded on hourly basis, printed log books shall be provided by the contractor at his own cost. The log books shall be securely kept in the pump house under the charge of a responsible person and shall be made available to any officer of the U.P. Jal Nigam meter on demand. Log books of previous month shall be deposited to the BSCL/ U.P. Jal Nigam meter concern every month. All the log books will be deposited to the Engineer in charge after completion of the contract. .

**2.9** For the purpose of operating pumps as above, it shall be the responsibility of the contractor to properly control, operate, maintain and safely keep all electrical/ Mechanical/ instrumentation units such as pump, motor, HT/LT panel, battery charger, ICP panels, capacitors etc. in working order.

#### **2.10 Periodically maintenance and overhauling of equipment**

Pumps / motors / cranes, exhaust fans, diesel generating set/ dewatering pump and all other equipment fitting etc. shall be operated and periodically overhauled as prescribed in the manuals provided by the manufacturer's standards, as per direction of Engineer in charge and schedule in RFP document.

**2.11** All electrical installations shall also be operated and maintained periodically and checked for its performance as per manual provided by the manufacturer's standards, as per directions of Engineer in-charge and schedule in RFP document.

**2.12** All type of valves and other apparatus shall also be operated and periodically maintained as per manufacturers manual & standards.

**2.13** All measuring equipment/devices for measuring pressure discharge/levels etc. shall be operated and periodically maintained as per manufacturers manual.

**2.14** Measuring equipment/devices relay etc. Requiring calibration or testing will be get tested and calibrated from manufacturers, authorized/reputed firms for which no extra payment shall be given to the contractor it is deemed to be included in the financial offer of the tender.

**2.15** Contractor shall prepare maps of schematic arrangement of Pumping Station and display in Pump House building and with in a period of 3 months time after award of contract.

### **COMMUNICATION SYSTEM**

**3.1** Contractor will have to keep control room 24 hours operational during the contract period.

**3.2** In the entire 3 shifts, personnel will have to be provided by contractor at control room for keeping all the information & record regarding running of project i.e., Pumping machinery, power failure, total production, level of OHT as well as any type of break down in system.

**3.3** All necessary stationary for record keeping at control room and log books etc. will have to be provided by the contractor free of cost.

#### **4. O&M OF PUMPING MACHINERY**

##### **4.1 PUMP**

###### **A. OPERATION**

Running of pumps through motors as and when required to meet out the required quantity of water.

###### **B. PREVENTIVE MAINTENANCE**

###### ***B.1 Daily Observation***

1. Check for any undue noise or vibration.
2. Reading of pressure, voltage and current is to be entered in log book after each hour.

###### ***B.3 Annual Inspection***

1. All instruments and flow meters if installed, should be recalibrated.
2. Pump should be tested to determine whether proper performance is being obtained.

###### **C. BREAK DOWN MAINTENANCE**

1. Opening of the casing, rotor assembly and find out the reasons for break down.
2. All modification, rectification, replacement shall be done except impeller. The impeller shall be referred to original manufacturer and get it repaired or replaced.

###### **C. BREAK DOWN MAINTENANCE**

#### **6 L.T. PANEL**

###### **A. OPERATION**

Making of circuit breakers ON/OFF of all the motors, fans, lights, and other fittings equipments as and when required.

###### **B. PREVENTIVE MAINTENANCE**

###### ***B.1 Daily Observation***

1. Check the phase indicating lamps.
2. Note reading of voltage, current, frequency etc.
3. Note energy meter readings.
4. Checking of all ACB/OCB/MCCB and its functioning, mountings etc.

###### ***B.2 Monthly Observation***

1. Examine contacts of relay and circuit breaker. Clean, if necessary.
2. Check setting of over current relay, No volt coil and tripping mechanism and oil in dashpot relay.

###### ***B.3 Quarterly Observation***

1. Check fixed and moving contacts of the circuit breakers/switches. Check and smoothen contacts with fine glass paper or file.
2. Check condition and quantity of oil/liquid in circuit breaker, auto transformer starter and rotor controller.

###### ***B.4 Semi Annual Observation***

1. Check for corrosion and take remedial measures. Check by megger the insulation resistance of switches, bus bar, starter-terminals, autotransformer, etc for phase to - earth and phase - to - phase, resistance.

###### ***B.5 Annual Observation***

1. All indicating meters should be calibrated.
2. Checking of control voltage at panels, and rectification.
3. Checking of all chutes its cleaning, greasing and replacement if needed.

4. Checking of operation mechanism for closing tripping etc.
5. Checking of dust, moisture, discoloration in chassis and checking of electrical connection.

#### C. BREAK DOWN MAINTENANCE

1. Do operating mechanism replacement if found defective.
2. Replace push buttons, switches, meters etc. if found defective

### **8 DISCONNECTING SWITCHES**

#### **A. OPERATION**

It is operated by hand level as and when required OR ON/OFF POSITION.

#### B. PREVENTIVE MAINTENANCE

1. Checking for nuts, bolts, conductor connections on insulators etc. tightening if found loose/and do replacement if found broken.
2. Checking of contacts its greasing and replacement if found burnt out or damaged.
3. Lever mechanism springs, locking etc. are to be checked.
4. Check the earth switch for satisfactory working.

#### C. BREAK DOWN MAINTENANCE

1. Replacement of the part/complete items as required/needed.
2. Check and replace the earth switches completely.

### **NEVER DO WHEN SOME REPAIR IS GOING ON THE OUTGOING CIRCUITS.**

### **9 SLUICE VALVE /BUTTER FLY VALVES**

#### A. OPERATION

Making the valve open and close as and when necessarily.

#### B. PREVENTIVE MAINTENANCE

1. Checking for full travel/rotation of the gate of the valve
2. Checking of the Lubrication and removal of leakage or other defect if found.
3. Placing of the gland in the stuffing box and lighting of nut & bolts.

### **10 ZERO VELOCITY VALVE**

#### **A. PREVENTIVE MAINTENANCE**

1. Checking of noise and vibration hydraulic pressure.
2. Checking of bye pass valve operation.
3. Checking hydraulic control of gate.
4. Calibration of spring.

#### B. BREAK DOWN MAINTENANCE

Replacement of any broken part if found with good one or repair one.

### **11 EXPANSION JOINT**

#### A. PREVENTIVE MAINTENANCE

1. Removal of leakage of zero velocity valves.
2. Tightening of nut and bolts.

#### B. BREAK DOWN MAINTENANCE

Removal of Leakage by replacing gland packing including replacement of damaged nut bolt.

### **12 NON RETURN VALVES**

#### A. OPERATION

Checking of the noise, vibration etc. when the valve gates open close during the pump operation.

#### B. BREAK DOWN MAINTENANCE

1. Replacement of any broken parts if found with good one or repaired one.
2. Replacement of nut and bolts if found defective/broken etc.

### **13 SUCTION/ DELIVERY PIPING**

#### **A. OPERATION**

1. Checking of line pressure, suction pressure, delivery pressure and valve position.
2. Doing ON/OFF position of dismantling joints while replacement of any requirement in the assembly line if needed.

#### **B. PREVENTIVE MAINTENANCE**

1. Checking of tightening of nut bolts etc.

#### **C. BREAK DOWN MAINTENANCE**

1. Replacement of nuts, bolts, pressure gauges, associated pipeline installations on assembling if found defective.

### **14 EARTHING AND LIGHTENING PROTECTION UNIT**

#### **A. PREVENTIVE MAINTENANCE**

1. Checking of terminals, joints of conductor strips and connection with pits.
2. Checking of unit series resistance, shunt capacitance, leakage current etc. as and when required.

#### **B. BREAK DOWN MAINTENANCE**

1. Replacement of parts/items, jointing of conductor strips, terminals if found defective.

### **15 CABLES AND CABLES TRAYS**

#### **A. OPERATION**

1. Checking of heating of cables by digital thermometer.

#### **B. PREVENTIVE MAINTENANCE**

1. Cleaning of cables and cables trays from dust, dirt, oil, grease etc.
2. Entries in the pump house should be restricted from mouse and other small insect/animals/birds etc.

#### **C. BREAK DOWN MAINTENANCE**

Replacement of damaged one with good one if found.

#### **NEVER USE SHARP IRON BLADES ON CABLES**

### **16 LIGHTING/ILLUMINATION SYSTEM**

#### **A. OPERATION**

Making ON/OFF through switches the necessary illumination required in the pump house switch yard and around campus.

#### **B. PREVENTIVE MAINTENANCE**

Checking of the terminals, electrical connection, mechanical fittings/fixtures in position for its satisfactorily.

#### **C. BREAK DOWN MAINTENANCE**

Replacement of parts, items etc, if found defective/damaged/burnt out with good one of reputed equivalent make.

**NEVER ON THE SWITCHES WHEN PARTICULAR FEEDER LINE IS UNDER REPAIR.**

***17. During O&M Period Charges for Electric consumption and Consumable Chlorine will not be in scope of bidder. it will be responsibility of ULB***



ई-मेल : ceiwupjn@gmail.com

## कार्यालय मुख्य अभियन्ता (वि०/याँ०)

उ० प्र० जल निगम (नगरीय), लखनऊ  
प्रधान कार्यालय 6, राणा प्रताप मार्ग, लखनऊ - 226 001

पत्रांक ५४५ / मु०अभि० (वि०/याँ०) / 2062-0063 / 22

दिनांक: ३१ / १२ / 2022

समस्त अधीक्षण अभियन्ता (वि०/याँ०)  
उ० प्र० जल निगम (नगरीय)  
लखनऊ / प्रयागराज / आगरा /  
गाजियाबाद।

विषय:- वि०/याँ० कार्यों से सम्बन्धित विभिन्न उपकरणों के मेक के सम्बन्ध में।

उपरोक्त विषयक वि०/याँ० कार्यों की निविदाओं में सम्मिलित विभिन्न उपकरणों के मेक में एकरूपता की दृष्टि से विभिन्न उपकरणों के मेक की सूची समय-समय पर जारी की गयी है। नवीनतम सूची संलग्न कर इस आशय से प्रेषित की जा रही है कि वि०/याँ० कार्यों की निविदाओं में आवश्यकतानुसार विभिन्न उपकरणों के मेक संलग्न सूची के अनुसार सम्मिलित करना सुनिश्चित करें।  
संलग्नक:- उपरोक्तानुसार।

*Au 31/12/22*  
(अरुण कुमार)  
मुख्य अभियन्ता (वि०/याँ०)

### पु०सं० एवं दिनांक उपरोक्तानुसार

प्रतिलिपि निम्नलिखित को सूचनार्थ एवं आवश्यक कार्यवाही हेतु प्रेषित:-

1. समस्त मुख्य अभियन्ता (क्षेत्रीय), उ० प्र० जल निगम (नगरीय), लखनऊ / प्रयागराज / आगरा / गाजियाबाद / कानपुर / गोरखपुर।
2. समस्त अधि०अभि० (वि०/याँ०) / परि०प्रबन्धक(वि०/याँ०) / (गंगा / यमुना / गोमती), उ० प्र० जल निगम (नगरीय)।

मुख्य अभियन्ता (वि०/याँ०)

**Office of The Chief Engineer (E/M), U.P Jal Nigam (URBAN), Lucknow**

**Make list for E/M Project**

Validity Status as on 31-12-2022

(A) **ELECTRICAL**

SL. No.	ITEMS/EQUIPMENTS	MANUFACTURER/VENDOR (Validity Date)
1	2	3
1	LT Motor, Induction Motor, AC Drive	LHP(10.06.2024), C.G. (18.07.2024)
2	LT/L.V. Electrical Control Panel &, Distribution Board/MCC/PMCC Panel	E-SQUARE SWITCHGEARS(18.02.2023), Schneider Electric(19.02.2023), UPAPL(16.02.24), SWATI (26.04.2024), Kandi (16.05.2024), Krypton (28.05.2024) SONAL(15.06.2024), CORONET ENGINEERS (09.09.2024) WUNDER(09.09.2024), UNISCADA (11.10.2024) AEC (01.11.2024), NEC (01.12.2024), TRANSCON POWER (20.12.2024), KEC (21.12.2024), SANC (30.12.2024), RST (05.08.2024) SUBTECH (06.09.2025)
3	HT Electrical Control Panel, VCB breaker	E-SQUARE SWITCHGEARS(18.02.2023), UPAPL(16.02.24), SWATI (26.04.2024), AEC (01.11.2024), KEC (21.12.2024), MEGAWIN (24.07.2025)
4	Distribution Transformer	TELAWNE(31.01.2023), Schneider Electric(19.02.2023), SERVOSTAR (12-09-24), SONAL(15.06.2024), VEI (22.10.2024), "VARDHMAN ELECTRO-MECH" (21.12.2024), ICON (23.12.2024),
5	Switchgear- Indicating Digital Meters, MCB, MCCB,RCCB, Motor Protection Relays, Relays, Air Circuit Breakers (LT), Fuse Conductor, Isolator	Schneider Electric(19.02.2023), E-SQUARE SWITCHGEARS(18.02.2023), RST (05.08.2024), SIMPLEX(25.08.2024), Industrial IT (29.12.2024), MEGAWIN (24.07.2025), C&S (12.12.2025), Havells (25.12.2025)
6	Servo Voltage Stabilizers/Automatic Voltage Stabilizers	SELVON (29.12.2025), SSNAB(25.03.2024), SONAL(15.06.2024), SPECTRON (25.08.2024), ICON (23.12.2024), Servocon (26.12.24), Blue Bird (04.09.2025), HPCS (11.03.2023)
7	Soft Starter/Starter	E-SQUARE SWITCHGEARS(18.02.2023), UNISCADA (11.10.2024) INNOVATIVE TECHNOMICS(10.02.23), CG (09.07.2024), SANC (30.12.2024)
8	Automatic Power Factor Control Panels	E-SQUARE SWITCHGEARS(18.02.2023), RST (05.08.2024)
9	Diesel Engines for D.G. set/Water Cooled Diesel Genset	Escort (10.08.2024)
10	Solar Water Pumps, Centrifugal Mono-Block, Open and Borewell, Submersibles and Solar powered pump set	SILCEF (31-12-2023), Falcon (13-09-2024), JASCO (23.03.2024), FLOTECH PUMPS (06.07.2025).
11	HT/LT. Solar Panel, Solar Photo, Voltaic Module Panel, Solar PV Module	Novasys (04.02.2023), WAAREE (19.03.2023), Sun Automate (25.11.2023), INA (11.02.2024), SONAL(15.06.2024), GAUTAM SOLAR (22.06.2024), BRAWN (22.06.2024), GOLDI (25.08.2024), PREMIER (12-09-2024) NOVUS GREEN (25.03.2025), Navitas Solar (16.06.2025).
12	Deferent Type Indore & Outdoor and Solar LED Light	Instapower (17.03.2024), RST (06.08.2024)
13	ACSR Conductors	<b>UPPCL Approved</b>
14	Wires & Cables	V-Mark(11-02-2024, Swarn (28.06.2024),Cords(25-07-2024), Special Cable (02.07.2024), KVV(28.07.2024), DARBAR (21.11.2024), NEC (01.12.2024), GEMSCAB (12.12.2024), KEC (21.12.2024), VISHAL (27.06.2025), PARAFLEX (06.07.2025) Axelon (20.12.2025) KEY (18.08.2024), GRANDLAY (13.07.2024)
15	Control Instrumentation Flexible & Submersible Cords	Cords (25.07.2024)
16	Cable trays	Udhat (04.02.23)

*[Handwritten Signature]*

**(B) MECHANICAL**

SL. No.	ITEMS/EQUIPMENTS	MANUFACTURER/VENDOR (Validity Date)
1	2	3
<b>0.1</b>	<b>Various type of Pump Set</b>	
1.1	Clear Water Submersible pump Motor set	Xylem (31.03.2024), ROCKWELL (01.06.2024), UNNATI(12.08.2024), MAK (02.09.2024), LUBI (07.09.2024), Calama (30.10.2025), Aqua (09.11.2025), Chandra (29.12.2025).Flotech (06.07.2022)
1.2	Horizontal Split Casing Pumps (HSCL)	FLOWMORE(13.06.2024), Kishor (04.08.2024).
1.3	Clear Water Horizontal, Submerged Centrifugal pump, submerged Centrifugal Pumpsets (HCF)	Aqua (09.11.2025), Flowmore (13.06.2024). MBH (31.12.2023)
1.4	V.T Pumps(Raw, Clear Water)	Flowmore (13.06.2024), Chandra (29.12.2025), Continental Indepth (24.05.2024), Aqua (09.11.2025), JASCO (23.03.2024).
1.5	Non clog Sewage submersible/V.T. Pumps	MBH(31.12.2023), JASCO (23.03.2024), Continental Indepth (24.05.2024), Kishor(04.08.2024), HET(16.08.2024), Aqua (09.11.2025).
1.6	Screw Pumps	Positive (03.03.2024), Risansi (27.01.2023).
<b>0.2</b>	<b>Various type of Main Piping &amp; Valves</b>	
2.1	All Types C.I./D.I. Valves & C.I./D.I. fittings,	Sigmaflow (11-02-2024), "IVC"(Nashik) (12.09.2024), IVC KolKata (26.01.2024), IVI KolKata (26.01.2024), AV (Industrial) (21-01-2024), Parchure (12.01.2024), Infra (08.02.2024), JUPITER (05.04.2024), R.G. Industries (30.06.2024), Sachdeva (30.06.2024), PURI (27.07.2024), AARKO(02.08.2024), Cair (23.08.2024), MARSH (03.09.2024), Kartar (03.09.2024), AVK (10.07.2025), SARKER (30.10.2025), SSPR (17.11.2025).
2.2	Sluice Gate	Micro Transmission Systems (24.06.2023), Parchure (12.01.2024), IVC KolKata (26.01.2024), IVI KolKata (26.01.2024), Cair (23.08.2024), SARKER (30.10.2025) JUPITER (05.04.2024), Marsh (04.09.2024).
2.3	Electrical Actuator	Micro Transmission Systems (24.06.2023), AUMA (25.11.2024) VOLTAS (Universal MPESL) (23.07.2024), Cair (23.08.2024).
2.4	Flow Meter-Electromagnetic, Ultrasonic, Fuel, Turbine, BTU/HEAT Meter	EUREKA INDUSTRIAL(16.01.2023),TIPL (19.02.2023), Flowtech (23.03.2024), ADDMAS (25.03.2024), MANAS (All Types Flowmeters) (28.07.2024), Atlantech (01.08.2024), ABB (07.08.2024), ELECTRONET(24.08.2024), AAROHI (03.09.2024), SAPCON (22.09.2025), UPC (19.10.2025), APLISENS (29.12.2024) Dwyer , (30.12.2024) MIRRANT (23.11.2025).
2.5	Water Meter	Everest (19.01.2023), UPC (19.10.2025).
2.6	Water Storage tank	Fresh flow (07.11.2023), UROPLAST(19.01.2023, Dhara (29.01.2024)
<b>0.3</b>	<b>Various type of Analyzer</b>	ABB (07.08.2024), Axis (04.08.2025).
<b>4</b>	<b>Various type of dosing Pumps &amp; Chlorination Systems</b>	
4.1	Chlorinator (STP, WTP), Dozer, Dozer Pump (Electro-mechanical), GAS/Liquid Chlorination System	Supreme Technology (26.08.2024), Industrial Devies (24.08.2024), JET CLEAN (16.12.2024), PICO DOSE (28.12.2024), Toshcom Jesco (10.07.2025) Chloro Tech (22.08.2025) CMC (30.10.2025), Positive (03.03.2024).
4.2	Fluoride, Arsenic, Iron Removal & R.O. Plant	UNICARE (21.06.2024), VOLTAS (Universal MPESL) (23.07.2024, ADWYN (16.02.2024).
<b>5</b>	<b>Silver Ionization Disinfection</b>	Senco (23.09.2025), RUTSUN (23.09.2025), JET CLEAN (16.12.2024).
<b>6</b>	<b>Various type of Lifting Tackles &amp; Cranes</b>	
6.1	Lifting Tackles, Cranes Electrics Hoists & Chain Pulley Block	Abhay (27.07.2024).
<b>7</b>	<b>Scada Automation &amp; Instrumentation</b>	
7.1	Analytical, Process Control, Scientific Instruments & Accessories	TOSHCON (10.07.2025).
7.2	PLC,SCADA /Automation	Emerson (17.02.2023) Schneider Electric(19.02.2023), Cimcom (14.12.23), iCAM(08-02-2024), ABB(17.03.2024), SWATI (26.04.2024), MCOM Technology(23.08.2024), PHOENIS CONTACT (22.11.2023), UNISCADA (11.10.2024), YOKOGAWA (26.09.2024), Industrial IT (29.12.2024), Axis (04.08.2025)
7.3	Large Video Screen, Industrial Video Screen,CCTV Systems	Delta (17.02.2023),TIPL (19.02.2023), SAN TELEQUIP (11.12.2025)
7.4	Level Instrument, Process Automation System	TIPL (19.02.2023), SAPCON (22.09.2025). Vega (22.12.2025)

*JMP* 

7.5	Temperature Transmitter, Temperature Sencor, Pressure Transmitter level, Pressure/ Temperature Gages	TIPL (19.02.2023), ABB (07.08.2024), MASS (23.08.2024), ELECTRONET (24.08.2024), SAPCON (22.09.2025), APLISENS(29.12.2024) Dwyer (30.12.2024), Vega (22.12.2025).
7.6	Process Equipment/Software	Parchure (12.01.2024).
8	<b>Various type of STP &amp; Equipments</b>	
8.1	Degrittor mechanism, Clarifier, Thickener, Clarifloculator, Diffuser, Decantor Centrifuge & Moving weir, Agitator,	Parchure (12.01.2024) W2P (14.12.2025).
8.2	Mechanical/Manual/Fine screen, Grit Mechanism/ Sludge thickener	Micro Transmission Systems (24.06.2023) Parchure (12.01.2024), Appilo (04.04.2024), VOLTAS (Universal MPESL) (23.07.2024).
8.3	Mechanical Multi Rack & Step Type Screens, Conveyers, Belt Filter Press with Sludge Thickner, Aerators/Mixers, Odor Controls Systems, Grit Separator	EUROTEK (28.02.2023), Micro Transmission Systems(24.06.2023) Parchure (12.01.2024), VOLTAS (Universal MPESL) (23.07.2024), Positive (03.03.2024), W2P (14.12.2025).
8.4	Sludge Dewatering Machine (Screw Press), Sludge Dryer's Clarifier, DAF System, Sand & Carbon Filters/ Screw dehydrator	SNP (15.12.2024), WELCOME (24.10.2024), AVALON (01.11.2024) Micro Transmission Systems(24.06.2023)
8.5	Model UV500, UV500-Compact, UV600, CHLSET, TURB200, ELPH-etc COD, TOC, BOD, pH, TSS, NH4, NO3, Clour, TDS, Silica, Iron etc.	TETHYS (19.12.2024)
8.6	Liquid Waste Handling Equipment of Various Types & Capacities, Solid Waste Collection and transportation Equipment of Various Types and Capacities, Range of Sweeping Machines and other special purpose equipment of Various Types and Capacities.	BES Engineering Solution (27.12.2024)
8.7	Compressor, Turbo ,Roots & Lobe Blower, Air Blower	Airvac (17.02.2023), Gardner BETA BLOWERS (16.08.23), TMVT (01-02-2024), ACME AIR Equipments(05.08.2024) TurboMAX (22.08.2025)
8.8	Cloth Disc Filters	"EUROTEK" (28.02.2023)

- N.B.:- 1. Any other equipment whose make is not mentioned above may be considered subject to approval by the Chief Engineer (E/M).  
2. Any make approved by U.P. Jal Nigam (Urban) missing in this list whose validity still exist shall be included in this list after representation received and considered by this office.

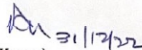
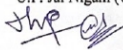
  
(Arun Kumar)  
Chief Engineer (E/M),  
U.P. Jal Nigam (Urban), Lucknow.  

## SCHEDULE FOR E&M WORKS

### SCHEDULE – ‘A’

#### **Purpose**

Tube well 09 Nos. (8 nos new & 1 no existing) along with SITC of pumping plant and its allied works are to be done at a site following the clearance of the land for construction the tube well which shall be followed by SITC of pumping plant with allied works for Re-Organization of Nagar Panchayat Mau Aima Water Supply Scheme Prayagraj Under AMRUT 2.0

The site of Tube well or Tube wells shall be shown to contractor or his agent before starting the work. The advantage of maximum yield from the strata met will be taken consequently as soon as the boring is complete. The contractor shall submit drawing as per schedule ‘C’ together with samples of strata for approval and the tube well shall not be put in until the approval of the Engineer or his representative has been obtained and officially communicated to the contractor.

The contractor should clearly understand that he will have to make his own arrangements for the T&P and other accessories that may be required for boring purposes and SITC of pumping plant.

The contractor shall be deemed to have carefully inspected the site to find what obstructions are there in the way of rapid progress as to include in his rates sufficient margin cover the cost of removing them. The rates in schedule ‘G’ will be all inclusive. No claim for any compensation in any shape arising out of such difficulties shall be entertained. Discharge-head characteristic curve of the pumping plant is necessary to be submitted while approval of GA drawing and data sheet of the **pumping plant with soft starter & control panel which shall be tested at the place of OEM prior to dispatch of the material at site.**

The contractor is so strongly advised to consult strata chart of boring done in the vicinity of the place. A few strata chart may available in the office of the Engineer. But those can only be taken as guide and no claim shall be entertained on the ground that strata actually met differs from the show on these charts.

Time is the essence of this contract. No request for extension of time will be entertained unless the Engineer finds the delay was unavoidable

### **SCHEDULE – ‘B’**

**List of the drawings to be provided by the contractor to the Engineer during the course of contract.**

1. Boring charted as per format provide by Engineer.
2. Proposed Tube Well assembly chart for Engineer’s approval.
3. GA drawing and data sheet of pumping plant with discharge-head characteristic curve and its QAP and also ATS and its cubical panel for approval of the competent authority and testing of the pumping plant at the place of OEM.

### **SCHEDULE – ‘C’**

**List of samples to be submitted by the contractor to the Engineer during the course of contract.**

The contractor shall deliver following samples. Either at the site of work or at the office as desired by the Engineer.

- (i) Sample of strata met with during boring.
- (ii) Any other samples if required by the Engineer.
  - (i) Samples of Lal Kuan Pea Gravel (Returnable)

### Schedule-'D'

Sl. No.	Particulars	
1	Discharge in LPM	
2	Total head in mtrs.	
3	WHP at total head	
4	Guaranteed Pump Effic. %	
5	HP input to Pump	
6	Guaranteed Motor Effic. %	
7	Overall efficiency %	
8	HP input to motor	
9	KWI to Motor	
10	Guaranteed KWI/ WHP	
11	Motor HP/ Stage	
12	Make/ Model	

**Note :**

- (i) Schedule 'E' has to be filled and uploaded in terms of discharge (Q)- head (H) & efficiency of pump and motor from the selected characteristic curve of model and make of the pumping plant. Any deviation or speculation in terms of discharge (Q)- head (H) & efficiency of pump and motor is observed that may be treated as ineligibility for qualifying the tender, liable to be turned down.
- (ii) Discharge and head may vary which is subjected to yield of the borewell and site conditions for which no extra payment shall be made.

**Signature & Seal of Tenderer**

**SCHEDULE – ‘E’**  
**List of Test to be conducted**

1. Yield test and test for measurement of sand contents.
2. Any other test as decided by Engineer.

**Note:-** Yield test shall be conducted through V-Notch or circular orifice meter or any other method approved by the Engineer.

**SCHEDULE – ‘F’**

**Completion Period.**

The complete works as specified herein shall be tested, passed and completed in all respects to the satisfaction of the Engineer or his authorized representative and handed over to Engineer concerned or his authorized representative. The contractors responsibility shall however not ceases until the guarantee period from the date of handing over as described earlier have been compiled successfully and uneventfully.

The Completion period shall be Scheduled as under:-

	The Completion period for Total work included in contract.	18 months
	The Completion period for each Tube Well from the availability of the Pin Point	45 days
	Completion period for SITC of pumping plant following the completion of pumping station or transmission line charged, which ever is earlier.	30 days

**Signature of Contractor**

**Dated.....**

## SCHEDULE – 'I'

### Mode and terms of payment for E/M works

Sr. No.	Item	Payment
<b>For Tubewell Construction</b>		
1.	After Successful Development of Tube well by O.P. Unit in satisfactory condition.	95%
2	After Trial & Run or Handing Over to Local Body whichever later	05%
<b>For pumping plant and Accessories</b>		
1.	After Supply of material in satisfactory condition.	70%
2.	After completion of Installation work	15%
3	After Successful Commissioning, testing and 3 Months trial run	10%
4	After Trial & Run or Handing Over to Local Body whichever later	5%
<b>For Scada System</b>		
1.	After Supply of material in satisfactory condition.	70%
2.	After completion of Installation work	15%
3	After Successful Commissioning, testing and 3 Months trial run	10%
4	After Trial & Run or Handing Over to Local Body whichever later	5%

**Signature of Contractor**

**Dated.....**

**SECTION – 6**

**SCHEDULES**

## **PROFORMA OF SCHEDULES**

### **SCHEDULE-"A"**

**LOCATION OF SITE-** Re-Organization of Nagar Panchayat Mau Aima Water Supply Scheme is located in Prayagraj district.

### **SCHEDULE – "B"**

**Schedule of materials to be issued to the contractor:**

<i>S. No.</i>	<i>Description of item</i>	<i>Qty</i>	<i>Rates in figures and words at which the material will Be charged to the contractor.</i>	<i>Place of Issue</i>
<b>1</b>	<b>2</b>	<b>3</b>	<b>4</b>	<b>5</b>
----- NIL -----				

### **SCHEDULE "C"**

#### **Civil Works-**

Drawings to be submitted:

**OHT Design & drawing , Soil Bearing Capacity to be prepared by IIT / NIT / reputed state and central/ private engineering institutions/organisation to be submitted by contractor at its own cost.**

Soil testing of O.H.T. Site will be done by contractor himself, by a reputed NABL approved laboratory. Charges for soil testing will also be borne by contractor.

Design & Drawing of O.H.T. will be get done by contractor. Vetting charges will be borne by contractor. Vetting is required to be done by any IIT / NIT / reputed state and central engineering institutions. Vetted design will be submitted by contractor.

The Contractor shall submit 1 (one) reproducible copy and 3 (three) prints of all As-Built Drawings (as per GIS mapping) clearly named as such to the Engineer for approval for the respective Section of the Works. After approval of the As Built Drawing the Contractor shall supply an electronic copy of the drawing in together with a licensed copy of the drafting software, and uploaded on portal as per prevailing govt. rules and as per direction of engineer in charge.

#### **E&M Works-**

List of the drawings to be provided by the contractor to the Engineer during the course of contract.

1. Boring charted as per format provide by Engineer.
2. Proposed Tube Well assembly chart for Engineer's approval.
3. GA drawing and data sheet of pumping plant with discharge-head characteristic curve and its QAP and PLC SCADA related E/M equipment for approval of the competent authority.

## SCHEDULE "D"

### **List of Samples to be submitted:**

**LIST OF SAMPLES TO BE SUBMITTED:** Tenderer whose offer is accepted has to submit the following samples in seven days before starting up the work.

1.	Local Sand( Ganga Fine Sand)	:	0.01 M <sup>3</sup>
2.	Coarse Sand	:	0.01 M <sup>3</sup>
3.	Coarse aggregate	:	0.01 M.
4.	Stone Ballast 25 mm to 40 mm gauge	:	0.01 M <sup>3</sup>
5.	Cement 43 grade Ordinary Portland Cement	:	1 Bag
6.	Reinforcement	:	1 M Piece of each dia to be used
7.	20 mm medium class G.I. Pipe	:	1 M Piece
8.	Epoxy Paint of approved make	:	1 Liter
9.	Weather Coat of approved make	:	1 liter
10.	Pipe of approved vendors for each dia	:	3 X 1 m

11. Sample for pipes and specials/SV/NRV/CI/DI DF pipe of approved vendor etc

Any other samples required by the Engineer from time to time returnable after the close of the contract but no payment shall be made if it perishes during this period.

In addition to the above the contractor may be required to submit any other sample that may be required by the engineer before the commencement or during the progress of the work. As regard specials the contractor shall submit list of manufacturers to be finalized by the engineer in charge. The materials of only approved manufacturers shall be brought at site for use in work.

E&M Works List of samples to be submitted by the contractor to the Engineer during the course of contract.

The contractor shall deliver following samples. Either at the site of work or at the office as desired by the Engineer.

- (i) Sample of strata met with during boring.
- (ii) Any other samples if required by the Engineer.

## SCHEDULE "E"

### **Tests to be conducted:**

**TESTS :** All the necessary and required tests before commencement of the work, during the construction and after the construction regarding material and work shall be conducted as per latest IS code/Manual on Water supply specifications or as desired by the Engineer as per terms and conditions of the contract documents. Contractor will also arrange for third party inspection and test certificate from the Manufacturer. All testing charges shall be borne by the contractor. Following test reports shall have to be submitted by the contractor.

As the work proceeds the following tests shall be carried out by the contractor at the time and in the manner desired by the Engineer-in-charge. All the materials, labour, T&P etc. shall be arranged by the contractor. The expenditure, which is incurred by him in this connection, shall be deemed to have been included in the respective rate and no extra claim whatsoever shall be admissible.

- (a) Tests of pipe and valves supplied shall be as required by relevant IS Code. Contractor shall have to submit third party inspection report from desired agency as sanctioned by UP Jal nigam(urban).

I/We have read, understood and accept for compliance, the above mentioned (Schedule-D to E) instructions and conditions of this schedule and have taken these factors into account while quoting rates in BOQ.

### **E&M Works-**

#### **(Furnished with respect to Submersible Pump Set)**

<b>Sl. No.</b>	<b>Particulars</b>	
<b>1</b>	Discharge in LPM	
<b>2</b>	Total head in mtrs.	
<b>3</b>	WHP at total head	
<b>4</b>	Guaranteed Pump Effic. %	
<b>5</b>	HP input to Pump	
<b>6</b>	Guaranteed Motor Effic. %	
<b>7</b>	Overall efficiency %	
<b>8</b>	HP input to motor	
<b>9</b>	KWI to Motor	
<b>10</b>	Guaranteed KWI/ WHP	
<b>11</b>	Motor HP/ Stage	
<b>12</b>	Make/ Model	

### **Note :**

(i) Schedule „E“ has to be filled and uploaded in terms of discharge (Q)- head (H) & efficiency of pump and motor from the selected characteristic curve of model and make of the pumping plant. Any deviation or speculation in terms of discharge (Q)- head (H) & efficiency of pump and motor is observed that may be treated as ineligibility for qualifying the tender, liable to be turned down.

(ii) Discharge and head may vary which is subjected to yield of the borewell and actual site conditions during the course of execution for which no extra payment shall be made.

## SCHEDULE “F”

### GENERAL RULES & DIRECTIONS :

Tender Inviting Authority	SUPERINTENDING ENGINEER, CONSTRUCTION CIRCLE, U.P. JAL NIGAM(URBAN), PRAYAGRAJ
---------------------------	--

Maximum percentage for quantity of items of work to be executed beyond which rates are to be determined in accordance with Clauses 12.2 & 12.3: See below.

### Definitions :

2(v)	Engineer-in-Charge	
a)	Civil	Executive Engineer, Construction Division (First) , U.P.Jal Nigam (Urban), Prayagraj
b)	Elect. & Mech	Executive Engineer, Construction division (E&M) , UP Jal Nigam,(Urban),Prayagraj.
2(viii)	Accepting Authority	Superintending Engineer, Construction Circle, U.P. Jal Nigam (Urban), Prayagraj.
2(x)	Percentage on cost of materials and labour to cover all overheads and profits	10%
2(xi)	Standard Schedule of Rates	
	a) Civil	UPJN (URBAN) SOR 2022-23
	b) Elect. & Mech.	UPJN (URBAN) SOR 2022-23
2(xii)	U.P. Jal nigam (urban)	U P Jal nigam (Urban)
9(ii)	Standard Contract form	As attached .

### Clause 1

(i)	Time allowed for submission of performance guarantee; programme Chart (Time and licenses), registration with EPFO, ESIC and BCOW Welfare board or proof of applying thereof from the date of letter of acceptance.	15 days
(ii)	Maximum allowable extension with late fee @0.1% per day of performance guarantee amount provided in (i) above:	7 days

### Clause 2

(i)	Authority for fixing Compensation under clause-2 :	Superintending Engineer, Construction Circle, U.P. Jal Nigam(Urban), Prayagraj.
-----	--	---

### Clause 5

Number of days from the date of issue of letter of acceptance for reckoning date of start :	As mentioned in letter of acceptance.
---	---------------------------------------

**Table of Milestone (s)**

S. no/ Milestone	Physical Progress	Financial progress	Cumulative time allowed (from date of start)	Amount to be withheld in case of non achievement of milestones
1	15% (Not less than 5% per month)	15%	03 Months	Upto 10 % of non achieved work value.
2	40 % (Not less than 8% permonth)	40%	06 Months	Upto 10 % of non achieved work value.
3	60 % (Not less than 7% per month)	60%	09 Months	Upto 10 % of non achieved work value.
4	80 % (Not less than 7% per month)	80%	12 Months	Upto 10 % of non achieved work value.
5	100 % (Not less than 7% permonth)	100%	15 Months	Upto 10 % of non achieved work value.

<b>Time allowed for execution of work</b>	<b>18 Months including 03 Months Trial and Run</b>
---	--

**Clause 5.4: Authority to decide:**

1	Extension of Time	1. Upto 50% of the time of completion- by signing authority of contract. 2. By next higher authority beyond the limit of 50% of time of completion.
2	Rescheduling of milestones	As above
3	Shifting the date of start in case of delay in handing over the site	Superintending Engineer, Construction Circle, U.P. Jal Nigam(Urban), Prayagraj.

**Clause 6**

Clause Applicable- (6 or 6A)	As per direction of Engineer-in-charge.
------------------------------	---

**Clause 7**

Gross work to be done together with net payment/adjustment of advances for material collected , if any, since the last such payment for being eligible to interim payment.	<b>5%</b> of contract value or approved mile stone from competent authority.
--	--

**Clause 7A**

Whether clause 7A shall be applicable	As decided by Engineer-in-charge
---------------------------------------	----------------------------------

### Clause 10 A

List of testing equipment to be provided by the contractor at field testing laboratory:

**(A) CIVIL**

- (B) Silt Content Jar**
- (C) Sieve Analysis**
- (D) Cube Mould**
- (E) Compressive strength testing machine**
- (F) Slump test**
- (G) All other remaining required testing equipment as per required by Engineer in charge.**

**(H) Electrical & Mechanical :-**

### Clause 10B (i & ii)

Whether clause 10B (i & ii) shall be applicable	If contract value is more than 500.00 Lacs
---	--

### Clause 11

Specifications as described under Chapter Specifications shall be followed.

### Clause 12

Type of work	Original work
12.2 & 12.3	Deviation limit beyond which clauses 12.2 & 12.3 shall apply. <b>100% (One hundred percent)</b>

### Clause 16

Competent authority for deciding reduced rates	a) Civil	Superintending Engineer(Civil)
	b) Elect. & Mech	Superintending Engineer(E&M)

### Clause 18

**a) Civil :-**

List of mandatory machinery, tools & plants to be deployed by the contractor at site:

1. Mechanical excavator ( JCB )
2. Concrete mixture
3. Tractor with trolley
4. D.G. Set ( 10 KVA and above as per required)
5. Pumping Arrangement for Dewatering of water
6. All other remaining machinery, tools & plants to be required for proper completion of works.



## **SCHEDULE-G (As Per BOO Uploaded)**

### **BILL OF QUANTITIES (Refer Schedule 'A')**

#### **Preamble**

1. The Bill of Quantities shall be read in conjunction with the Instructions to Bidders, Conditions of Contract, Special Conditions of Contract, Technical Specifications and Drawings.
2. The quantities given in the Bill of Quantities are estimated and provisional, and are given to provide a common basis for bidding. These are liable to change upto any extent for which no claim shall be admitted whatsoever **except as provided under the contract**. The basis of payment will be the actual quantities of work ordered and carried out, as measured by the Contractor and verified by the Engineer and valued at the rates and prices tendered in the priced Bill of Quantities, where applicable, and otherwise at such rates and prices as the Engineer may fix within the terms of the Contract.
3. The rates and prices shall be quoted in percentage terms and resultant contract price will be entirely in Indian Currency.
4. General directions and descriptions of work and materials are not necessarily repeated or summarized in the Bill of Quantities. References to the relevant sections of the contract documentation shall be made before entering % against the Bill of Quantities.
5. The method of measurement of completed work for payment shall be in accordance with the UPJN/UPPWD/CPWD Specifications unless otherwise provided in contract.
6. Rock is defined as all materials which, in the opinion of the Engineer, require blasting, or the use of metal wedges and sledgehammers, or the use of compressed air drilling for its removal, and which cannot be extracted by ripping with a tractor of at least 150kw with a single rear mounted heavy duty ripper.

**Note: The payment for all works shall be made as per availability of funds in the division from concerned body. Regarding this no additional claim made by contractor will be considered.**

## **SCHEDULE - H**

### (ADDITIONAL ITEM RATES)

All extra or additional work done or substituted work in place of work omitted by order of Engineer shall be valued at the rates and price set out in the contract, if in the opinion of the Engineer same shall be applicable. If the contract does not contain any rates or prices applicable to the extra or additional work, then the rates shall be minimum of the following:

- (a) Derived from the tendered/contract rates of the contract of similar class of work.
- (b) Derived from the U.P. Jal Nigam(Urban) schedule of rates of the year in which the work actually done for the Distt. Prayagraj

If the rates cannot be decided as above for additional/extra work, then such class of work shall be agreed upon between the Engineer and contractor in writing prior to the work being taken up in hand but it shall be based on U.P Jal Nigam/U.P PWD/U.P Irrigation/CPWD schedule of rate.

Sign of Contractor

## **SCHEDULE - I**

### **(DEPARTMENTAL ISSUE RATES OF MATERIALS)**

All material shall be arranged by the contractor at his own cost required for completion of the work in all respect.

**Note-** Any material if available in U.P. Jal Nigam & demanded by the contractor may be issued to the contractor but for such material, the contractor shall not claim delay in work. Such material shall be issued at the rates greater of the following:

1. Current market rate of that time.
2. Book value plus store handling charges.

I/We have read, understood and accept for compliance, the above mentioned instructions and conditions of this schedule and have taken these factors into account while quoting rates in schedule-G.

Sign of Contractor

## SCHEDULE-J

Mode of Payment (if applicable)

### SCHEDULE – „J“ (Civil)

#### Mode of Payment

##### 1. Mode of Payment for Over Head Tank:

The interim payment shall be regulated as below as per cost:

Sr. No.	Particulars	% of payment which will be released	Progressive % of Payment to be released
1	Excavation in foundation, in every kind of soil laying lean concrete casting of raft foundation and columns up to G.L.	20%	20%
2	Completion of staging up to bottom of ring beam including supply of all CIDF pipe and sluice valve with test certificates. Refilling of the excavated earth and completion of staging up to bottom ring beam.	15%	35%
3	Casting of bottom ring beam, bottom dome, conical wall. balcony.	20%	55%
4	Casting of cylindrical walls of tank and top dome	10%	65%
5	Fixing of vertical pipe and wall and construction of stair case up to balcony level.	10%	75%
6	Completion of misc. items such as remaining stair case, fixing of lighting conductor, ventilator, S.S. ladders, S.S. Gate water level indicator railing and fitting etc.	10%	85%
7	Finishing of work to the satisfaction of engineer-in-charge & testing of water tightness, construction of floor with drain, sluice valves with chambers, painting of metal as well as concrete surface.	5%	90%
8	Trail testing or handing over of the OHT to be competent authority as directed by Engineer-in-charge whichever is later	10%	100%

##### 2. Mode of Payment for Rising Main/Distribution System/ House connection:

Payment will be made after completion of individual item as per measurement basis & following percentage will be deducted from each running bill:

Sl. No.	Particulars	Percentage of Lump Sum Amt. of the Works.
1	Excavation, Carting, Laying & Jointing of pipe including refilling of trenches including permanent reinstatement of road (Work Complete in all respect)	80%
2	For Hydraulic testing of pipe line	5%

3	For Testing & commissioning of Zone wise pipe line	5%
4	For three (3) month trial run period or handing over the completed works to Nagar Panchayat whichever is later	10%

### 3. Mode of Payment for Building Works:

#### (a) For Staff Quarter & Pump House:

Sl. No.	Particulars	Percentage of Lump Sum Amt. of the Works.
1	Upto plinth	20%
2	Plinth to super structure	40%
3	Completion of all works including electricity fitting etc.	30%
4	Handing over the completed works to Nagar Panchayat.	10%

#### (b) For Boundary Wall:

The interim payment shall be regulated as below as per Cost:

Sl. No.	Particulars	Percentage of Lump Sum Amt. of the Works.
1	Upto plinth	20%
2	Plinth to super structure	40%
3	Completion of all works including painting, finishing, fixing of barbed wire etc. complete in all respect.	30%
4	Handing over the completed works to Nagar Panchayat.	10%

- (i) Payment will be made after completion of individual item as per measurement basis.
- (ii) Payment for various works necessary to be carried out for repairing of Staff Quarter, Pump House, Boundary wall and existing Over Head Tank shall be made as per actual measurement according to attached schedule of works /BOQ and satisfaction of engineer-in-charge.
- (iii) 10% cost of each running bill will be deducted which will be released after 3 months trial run period & handing over the completed works to concerning local body.

### Mode and terms of payment for E/M works

Sr. No.	Item	Payment
<b>For Tubewell Construction</b>		
1.	After Successful Development of Tube well by O.P. Unit in satisfactory condition.	95%
2	After Trial & Run or Handing Over to Local Body whichever later	05%
<b>For pumping plant and Accessories</b>		
1.	After Supply of material in satisfactory condition.	70%
2.	After completion of Installation work	15%
3	After Successful Commissioning, testing and 3 Months trial run	10%
4	After Trial & Run or Handing Over to Local Body whichever later	5%
<b>For Scada System</b>		
1.	After Supply of material in satisfactory condition.	70%
2.	After completion of Installation work	15%
3	After Successful Commissioning, testing and 3 Months trial run	10%
4	After Trial & Run or Handing Over to Local Body whichever later	5%

**Signature of Contractor**

**Dated.....**

**SCHEDULE - K**  
(CONSUMPTION OF MATERIALS)

On completion of each class of work or of each section, the consumption statement shall be prepared for such materials by the contractor himself. In order to determine excess or short consumption of materials, the actual quantities used by the contractor shall be compared to the theoretical worked out quantities. However if there is any excess or short consumption of materials, the following procedures shall be adopted unless otherwise specified.

No action shall be taken if the actual consumption does not exceed or is short by  $\pm 3\%$  of the theoretical consumption as the case may be. The variation will not be taken as a matter of routine and will have to be properly justified in each case by the Engineer-in-charge. If the actual consumption exceed theoretical consumption by more than the permissible limit as mentioned earlier, recovery shall be made for the excessive consumption of material at penal rate of twice the rate from the tenderer. It shall be the responsibility of the tenderer to bring such a case to the notice of the Engineer-in-charge for further action whose decision in all such cases shall be final. In cases of material arranged by contractor, where the actual consumption is short of the theoretical consumption and beyond the permissible limits defined earlier, the recovery of cost of materials thus saved shall be made from the tenderer at double the market rate and in case of material supplied by the department, if actual consumption is short of theoretical consumption beyond permissible limits the recovery of the material shall be made at double the issue rate. It shall also be determined whether the stability of the structure or the work is adversely affected by short consumption of materials and in cases where it is likely to be so, the work shall be rejected. The decision of the Engineer in-charge in the regards shall be final.

Sign of Contractor

**SECTION – 7**

**GUARANTEES & FORMS**

**STANDARD FORM OF AGREEMENT**

{Notes on Standard Form of Agreement: The Agreement should incorporate any corrections or modifications to the Bid resulting from corrections of errors as mentioned in Instructions to Bidders.}

*Standard Form: Agreement*

**Agreement**

This agreement, made the ..... day of ..... of 20. Between ..... ,  
(hereinafter called “the Employer”) of the one part, and

.....

.....

.....

[name and address of Contractor] (hereinafter called “the Contractor” of the other part).

Whereas the Employer is desirous that the Contractor execute the **Work of Construction of**  
.....at .....District..... (hereinafter  
called “the Works”) and the Employer has accepted the Bid by the Contractor for the execution and  
completion of such Works and the remedying of any defects therein at a cost of Rupees  
.....(Rs ..... only )

**NOW THIS AGREEMENT WITNESSETH** as follows:

1. In this Agreement, words and expressions shall have the same meanings as are respectively assigned to them in the Conditions of Contract hereinafter referred to, and they shall be deemed to form and be read and construed as part of this Agreement.
2. In consideration of the payments to be made by the Employer to the Contractor as hereinafter mentioned, the Contractor hereby covenants with the Employer to execute and complete the Works and remedy any defects therein in conformity in all aspects within the provisions of the Contract.
3. The Employer hereby covenants to pay the Contractor in consideration of the execution and completion of the Works and the remedying the defects wherein the Contract Price or such other sum as may become payable under the provisions of the Contract at the times and in the manner prescribed by the Contract.
4. The following documents shall be deemed to form and be read and construed as part of this Agreement, viz:
  - i) Letter of Acceptance;
  - ii) Notice to proceed with the works;

- iii) Contractor's Bid including Integrity Agreement.
- iv) General Conditions of Contract, Special Conditions of Contract.
- v) Specification & Particular Specifications.
- vi) Drawings & Schedules;
- vii) Bill of Quantities; and
- ix) Any other document forming part of the contract.

In witness whereof the parties thereto have caused this Agreement to be executed the day and year first before written.

The Common Seal of

.....  
 .....

was hereinto affixed in the presence of:

Signed, Sealed and Delivered by the said to,

.....  
 .....  
 .....

In the presence of:

Binding Signature of Employer's authorised representative.

.....  
 .....

Binding Signature of Contractor

.....  
 .....  
 .....

**Form of Performance Security (Guarantee)****BANK GUARANTEE BOND**

THIS GUARANTEE made this ..... day of .....by ..... (hereinafter referred to as "the Bank" which expression shall, unless repugnant to the context include its successors & assignees) of the one part IN FAVOUR of ....., U P Jal Nigam, .....(hereinafter called "the Nigam" which expression shall, unless repugnant to the context include its successors & assignees) of the other part.

**WHEREAS** the Nigam having offered to accept the terms and conditions of the proposed agreement between the Nigam and MESSERS ..... (hereinafter called "the said Contractor(s)") for the work.....(Hereinafter called "the said Contract") having agreed to production of an irrevocable Bank Guarantee for Rs..... (Rupees ..... only) as a security/guarantee from the contractor(s) for compliance of his obligations in accordance with the terms and conditions in the said Contract.

**AND WHEREAS** the Bank has accordingly at the request of the said Contractor(s) agreed to furnish this guarantee.

NOW THIS DEED WITNESSES AS FOLLOWS:

1. In consideration of Rs. .... (Rupees..... only)
2. The Bank shall pay to the Nigam on demand the sum under the clause above without demur and without requiring the Nigam to invoke any legal remedy that may be available to it, it being understood and agreed FIRSTLY that the Nigam shall be the sole judge of and as to whether the said Contractor(s) have committed breach, if any, of the terms and conditions of the said Contract and the extent of losses, damages, costs, charges and expenses caused to or suffered by or that may be caused to or suffered by the Nigam from time to time shall be final and binding on the Bank and SECONDLY that the right of the Nigam to recover from the Bank any amount under this Guarantee shall not be affected or suspended by reason of the fact that any dispute or disputes have been raised by the said Contractor(s) with regard to their liability or the proceedings are pending before any Tribunal, Arbitrator(s) or Court with regard thereto or in connection therewith, and THIRDLY that the Bank shall immediately pay the sum under clause to the Nigam on demand and it shall not be open to the Bank to know the reasons of or to investigate or to go into the merits of the demand or to question or to challenge the demand or to know any facts affecting the demand, and LASTLY that it shall not be open to the Bank to require proof of the liability of the said Contractor(s) to pay the amount before paying the sum demanded under clause above.
3. This guarantee is in addition to and not in substitution for any other guarantee executed by the Bank in favour of the Nigam on behalf of the said Contractor(s).
4. The said Contractor(s) and the Nigam will be at liberty to vary and modify the terms and conditions of the said Contract without affecting this guarantee notice of which modification to the Bank hereby waived.
5. This guarantee shall not be affected by any change in the constitution of the bank or of the said Contractor(s) nor shall the guarantee be affected by any change in the constitution of the Nigam or by amalgamation or absorption with any other body corporate and this guarantee will be available to or enforceable by such body corporate.

6. The neglect or forbearance of the Nigam in enforcing any payments of moneys, the payment whereof is intended to be hereby secured or the giving of time by the Nigam for the payment thereof shall in no way, release the Bank from its liability under this deed.
7. This guarantee is irrevocable except with the written consent of the Nigam.
8. This guarantee shall come into force from the date hereof and shall remain valid till ..... but if the period of the said Contract is, for any reason, extended and upon such extension if the said Contractor(s) fail to furnish or renew guarantee for the extended period, the Bank shall pay to the Nigam the said sum of Rs..... or such lesser sum as the Nigam may demand.
9. The Bank further agrees with the Nigam that the Nigam shall have the fullest liberty without our consent and without affecting in any manner our obligation & hereunder to vary any of the terms and conditions of the said Contract or to extend time of performance by the said Contractor(s) from time to time or to postpone for any time or from time to time any of the powers exercisable by the Nigam against the said contractor(s) and to forbear or enforce any of the terms and conditions relating to the said Contract and we shall not be relieved from our liability by reason of any such variation, or extension being granted to the said Contractor(s) or for any forbearance, act of omission on the part of the Nigam or any indulgence by the Nigam to the said Contractor(s) or by any such matter or thing whatsoever which under the law relating to sureties would, but for this provision, have effect of so relieving us.

10.

Notwithstanding anything stated hereinbefore the liability of the Bank under the guarantee is restricted to Rs. .... (Rs. .... only). This guarantee shall remain in force upto .....unless a demand or claim under the guarantee is presented to the Bank in writing within twelve months from the date of expiry all rights of the Nigam under the guarantee shall be forfeited and the Bank shall be released and discharged from all liabilities hereunder.

IN WITNESS WHEREOF

.....day of .....

For.....

(Indicate the name of the Bank)

**Note:** The Bank Guarantee should be verifiable and encashable from a branch situated in a city where the office of Divisional Officer is located.

**INDENTURE FOR SECURED ADVANCES****(To be executed on stamp of appropriate value)**

THIS INDENTURE made the \_\_\_\_\_ day of \_\_\_\_\_ between \_\_\_\_\_ (expression shall where the context so admits or implies be deemed to include his executors, administrators and assigns) of the one part and the Executive Engineer, -----U P Jal Nigam, ---- ( hereinafter called as the "Engineer" which expression shall where the context so admits or implies be deemed to include his successors in office and assigns) of the other part.

WHEREAS by an agreement no----- dated \_\_\_\_\_ ( hereinafter called the said Agreement) the Contractor has agreed.

AND WHEREAS the Contractor has applied to the Engineer that he be allowed advances on the security of materials absolutely belonging to him and brought by him to the site of the works, the subject of the said Agreement for use in the construction of such of the works as he has undertaken to execute at rates fixed for the finished work ( inclusive of the cost of material and labour and other charges)

AND WHEREAS the Engineer has agreed to advance to the contractor the sum of Rupees \_\_\_\_\_ (in words, Rupees \_\_\_\_\_) on the aforesaid security and has reserved to himself the option of making any further advance or advances on security of aforesaid nature, the quantities and other particulars of the materials on the security of which the advance or advances are made being detailed in Part-II of a running account bill for the said works signed by the Contractor on ..... and the Engineer has reserved to himself the option of making any further advances on the security of other materials brought by the Contractor to the site of said works.

NOW THIS INDENTURE WITNESS that in pursuance of the said Agreement and in consideration of the sum of Rs. \_\_\_\_\_ on or before the execution of these presents paid to the Contractor by the Engineer ( the receipt whereof the Contractor hereby acknowledges) and of such further advances ( if any) as may be made to him as aforesaid, the Contractor does hereby covenant and agree with the Engineer and declare as follows.

1. That till the time such material, against which advance has been made, is utilised on the work for which it is meant, the ownership rights of material shall rest with the UPJN and the Contractor shall not have any claim whatsoever except as provided herein.
2. That the said sum of Rs ..... so advanced by the Engineer to the Contractors as aforesaid shall be employed by the Contractor in or towards expediting the execution of the said works and for none other purpose whatsoever.
3. That the material detailed in the said running account bill which have been offered to and accepted by the Engineer as security are absolutely the Contractor's own property and free from encumbrances of any kind and the Contractor will not make any application for or receive a further advance on the security of materials which are not absolutely his own property, and free from encumbrances of any kind and the Contractor indemnifies the Engineer against all claims to any materials in respect of which an advance has been made to him as aforesaid.

4. That the materials detailed in the said running account bill and all other materials on the security of which any further advance or advances may hereafter be made as aforesaid (hereinafter called the said materials) shall be used by the contractor solely in the execution of the said works in accordance with the directions of the Engineer and in the terms of the said Agreement.
5. That the Contractor shall make at his own cost all necessary and adequate arrangement for the proper watch, safe custody and protection against all risks of the said materials and that until used in construction as aforesaid, the said materials shall remain at the site of the said works in the Contractor's custody and on his own responsibility and shall at all times be open to inspection by the Engineer or any officer authorised by him. In the event of the said materials or any part thereof being stolen, destroyed or damaged, the Contractor will forthwith replace the same with other materials of like quality or repair and make good the same as required by the Divisional officer.
6. That the said materials shall not, on any account,, be removed from the site of the said works except with the written permission of the Engineer or an officer authorised by him in that behalf.
7. That the advances shall be repayable in full when or before the contractor receives payment from the Engineer of the price payable to him for the said works under the terms and provisions of the said agreement, provided that if any intermediate payments are made to the contractor on account of work done, then on occasion of each such payment, the Engineer will be at liberty to make a recovery from the contractor's bill for such payment by deducting there from the value of the said materials then actually used in the construction and in respect of which recovery has not been made previously , the value for this purpose being determined in respect of each description of materials at the rates at which amounts of advances made under these presents were calculated.
8. That if the Contractor shall at any time make any defaults in the performance or observance of any of the terms and provisions of the said agreement or of these presents, the total amounts of the advance or advances that may still be owing to the Engineer shall immediately on the happening of such defaults be repayable by the Contractor to the Engineer , together with interest thereon at 8 (eight) per annum from the date of respective dates of such advance of advances to the date of repayment and with all costs, charges, damages and expenses incurred by the Engineer in or for the recovery thereof or the enforcement of this security or otherwise by reason of the default of the Contractor and the Contractor hereby covenants and agrees with the Engineer to repay and pay the same respectively to him accordingly.
9. That the Contractor hereby charges all the said materials with the repayment to the Engineer of the said sum of Rs. .... and any further sum or sums advanced as aforesaid and all costs, charges, damages and expenses payable under these presents PROVIDED ALWAYS and it is hereby agreed and declared that notwithstanding anything in the said agreement and without prejudice to the powers contained therein, if and whenever the covenant for Payment and repayment hereinbefore contained shall become enforceable and the money owing shall not be paid in accordance therewith, the Engineer may at any time thereafter adopt all or any of the following courses as he may deem best.
  - a) Seize and utilise the said materials or any part thereof in the completion of the said works on behalf of the Contractor in accordance with the provisions in that behalf contained in the said agreement, debiting the Contractor with the actual cost of effecting such completion and the amount due in respect of advances under these presents and crediting the contractor with the value of work done as if he had carried it out in accordance with the said agreement and at the rates thereby provided. If the balance is against the Contractor, he is to pay the same to the Engineer on demand.

b) Remove and sell by public auction the seized materials or any part thereof and out of the moneys arising from the sale, retain all the sums aforesaid repayable to the Engineer under these presents and pay over the surplus ( if any) to the Contractor.

c) Deduct all or any part of the money owing out of the security deposits or any sum due to the contractor under the said Agreement.

10. That except in the event of such default on the part of the contractor as aforesaid interest on the said advance shall not be payable.

11. That in the event of any conflict between the provisions of these presents and the said Agreement, the provisions of these presents shall prevail and in the event of any dispute or difference arising over the construction or effect of these presents, the settlement of which has not been hereinbefore expressly provided for the same shall be referred to the Superintending Engineer,.....Circle  
....., whose decision shall be final.

IN WITNESS WHEREOF the said ..... and .....  
..... by the order and under the direction of the Engineer have hereunto set their respective hands the day and year first above written.

Signed, sealed and delivered by the said Contractor in the presence. Witness

Signature

Name:-

Address

Signed by Engineer in presence of

Witness :

Signature :

Name :

Address :

**FORM OF BANK GURANTEE FOR MOBILISATION ADVANCE**

(On non-judicial paper of an appropriate value)

To,

.....  
 U.P. Jal Nigam  
 .....  
 .....

Subject:.....  
 (Name of work and Contract No.)

THIS GUARANTEE made this ..... day of .....by ..... (hereinafter referred to as 'the Bank" which expression shall, unless repugnant to the context include its successors & assignees) of the one part IN FAVOUR of ....., U P Jal Nigam, ..... (hereinafter called "the Nigam" which expression shall, unless repugnant to the context include its successors & assignees) of the other part.

**WHEREAS** the Nigam, having agreed under the terms & conditions of Contract no.....dated ..... (hereinafter called "the Contract") executed between the Nigam and M/S ..... (hereinafter called "the said Contractor(s)") to make, at the request of the said Contractor(s) thereunder, a lump sum mobilization advance of Rs ..... (Rs..... only ) for utilizing it for the purpose and in accordance with the terms and conditions in the said Contract.

**AND WHEREAS** the Bank has accordingly at the request of the said Contractor(s) agreed to furnish this guarantee.

NOW THIS DEED WITNESSES AS FOLLOWS:

1. In consideration of Rs. .... (Rupees..... only).
2. If the contractor fails to utilize the said advance for the purposes of the said contract and/or the said advance together with interest thereon as aforesaid is not fully recovered by the Nigam, the Bank, hereby unconditionally and irrevocably undertakes to pay to the Nigam on merely demand and without demur or protest to the extent of the said sum on claim made by the Nigam on us against non-utilization/ mis-utilisation of the said advance and/or reason of Nigam not being able to recover in full the said sum of Rs ..... with interest as aforesaid.
3. The Bank shall pay to the Nigam on demand the sum under the clause above without demur and without requiring the Nigam to invoke any legal remedy that may be available to it, it being understood and agreed FIRSTLY that the Nigam shall be the sole judge of and as to whether the said Contractor(s) have committed breach, if any, of the terms and conditions of the said Contract and the extent of losses, damages, costs, charges and expenses caused to or suffered by or that may be caused to or suffered by the Nigam from time to time shall be final and binding on the Bank and SECONDLY that the right of the Nigam to recover from the Bank any amount under this Guarantee shall not be affected or suspended by reason of the fact that any dispute or disputes have been raised by the said Contractor(s) with regard to their liability or the proceedings are pending before any Tribunal, Arbitrator(s) or Court with regard thereto or in connection therewith, and THIRDLY that the Bank shall immediately pay the sum under clause to the Nigam on demand and it shall not be open to the Bank to know the reasons of or to investigate or to go into the merits of the demand or to question or to challenge the demand or to know any facts affecting the demand, and LASTLY that it shall not be open to the Bank to require proof of the liability of the said Contractor(s) to pay the amount before paying the sum demanded under clause above.

4. This guarantee is in addition to and not in substitution for any other guarantee executed by the Bank in favour of the Nigam on behalf of the said Contractor(s).
5. The said Contractor(s) and the Nigam will be at liberty to vary and modify the terms and conditions of the said Contract without affecting this guarantee notice of which modification to the Bank hereby waived.
6. This guarantee shall not be affected by any change in the constitution of the bank or of the said Contractor(s) nor shall the guarantee be affected by any change in the constitution of the Nigam or by amalgamation or absorption with any other body corporate and this guarantee will be available to or enforceable by such body corporate.
7. The neglect or forbearance of the Nigam in enforcing any payments of moneys, the payment whereof is intended to be hereby secured or the giving of time by the Nigam for the payment thereof shall in no way, release the Bank from its liability under this deed.
8. This guarantee is irrevocable except with the written consent of the Nigam.
9. This guarantee shall come into force from the date hereof and shall remain valid till ..... but if the period of the said Contract is, for any reason, extended and upon such extension if the said Contractor(s) fail to furnish or renewe guarantee for the extended period, the Bank shall pay to the Nigam the said sum of Rs .....or such lesser sum as the Nigam may demand.
10. It shall not be necessary for the Nigam to proceed against the said Contractor before proceeding against the Bank and the guarantee herein contained shall be enforceable against the Bank notwithstanding that any security the Nigam may have obtained from the Contractor shall at the time when proceedings are taken against the said Bank hereunder be outstanding or unrealized.
11. The Bank further agrees with the Nigam that the Nigam shall have the fullest liberty without our consent and without affecting in any manner our obligation & hereunder to vary any of the terms and conditions of the said Contract or to extend time of performance by the said Contractor(s) from time to time or to postpone for any time or from time to time any of the powers exercisable by the Nigam against the said contractor(s) and to forbear or enforce any of the terms and conditions relating to the said Contract and we shall not be relieved from our liability by reason of any such variation, or extension being granted to the said Contractor(s) or for any forbearance, act of omission on the part of the Nigam or any indulgence by the Nigam to the said Contractor(s) or by any such matter or thing whatsoever which under the law relating to sureties would, but for this provision, have effect of so relieving us.

12.

Notwithstanding anything stated hereinbefore the liability of the Bank under the guarantee is restricted to Rs. .... (Rs. .... only). This guarantee shall remain in force upto ..... unless a demand or claim under the guarantee is presented to the Bank in writing within twelve months from the date of expiry all rights of the Nigam under the guarantee shall be forfeited and the Bank shall be released and discharged from all liabilities hereunder.

IN WITNESS WHEREOF

.....day of ..... For.....

(Indicate the name of the Bank)

**Note:** The Bank Guarantee should be verifiable and encashable from a branch situated in a city where the office of Divisional Officer is located.

---

---

# DRAWING

---



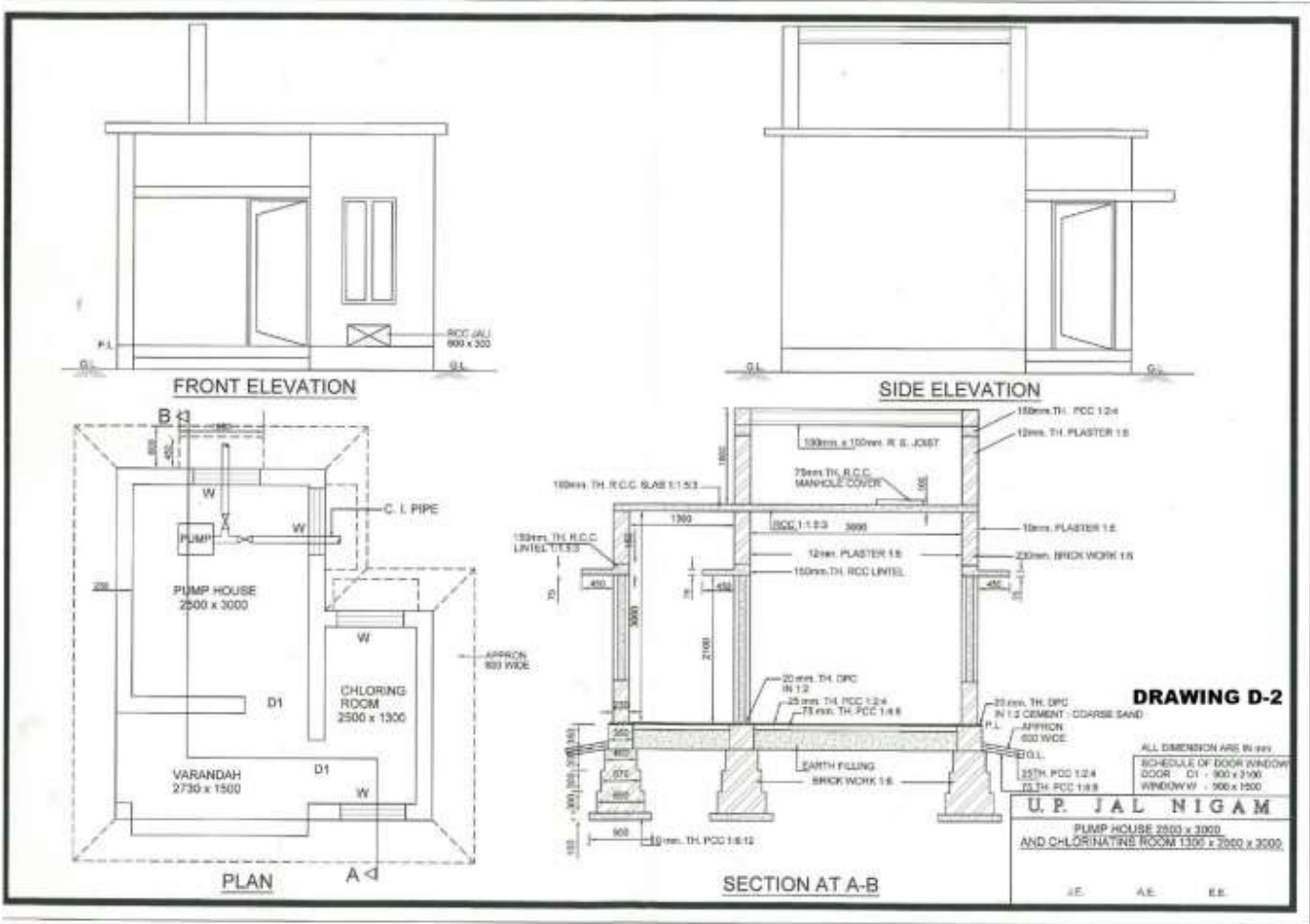

# BYE PASS CHAMBER (1150MM X 1000MM X 1000MM)

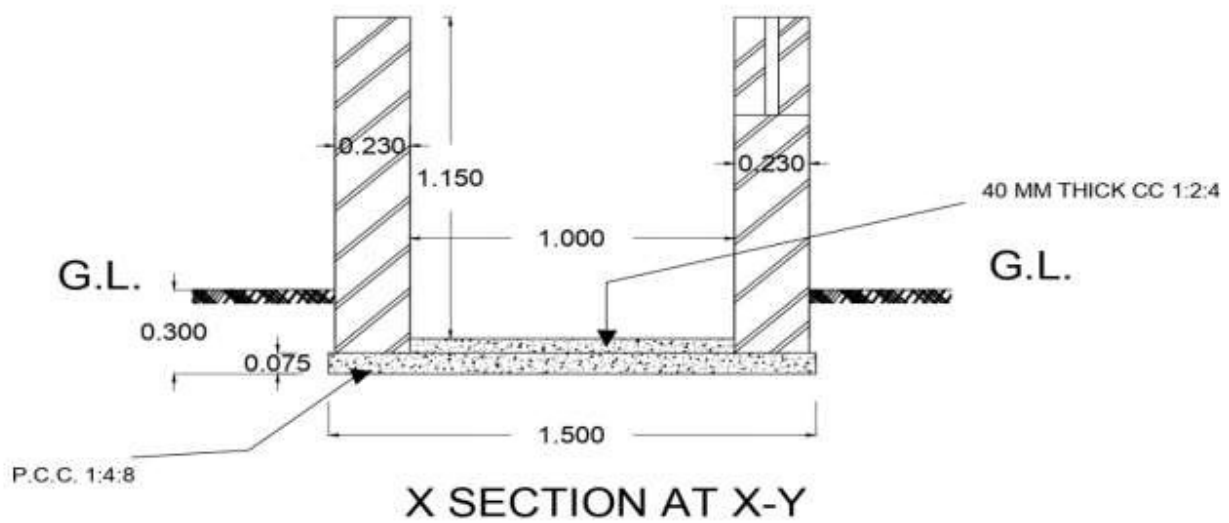
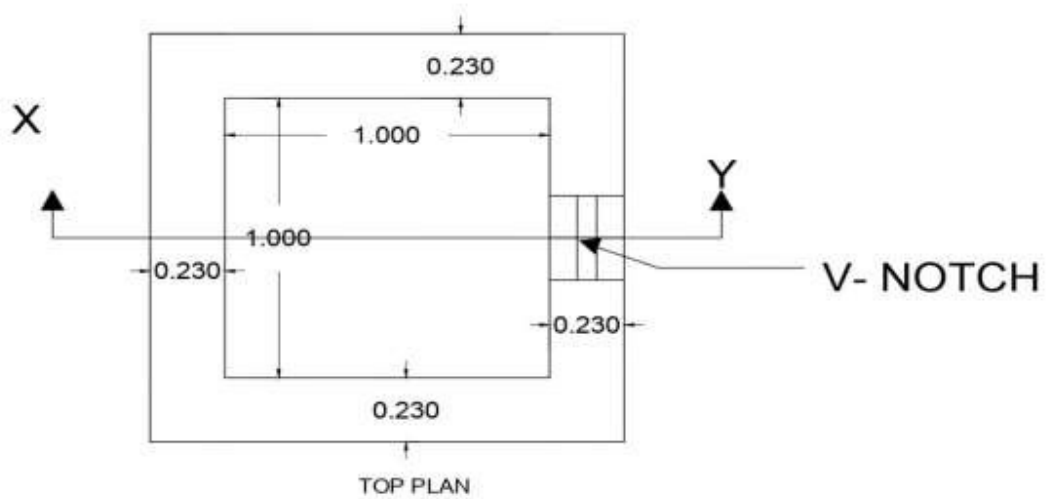

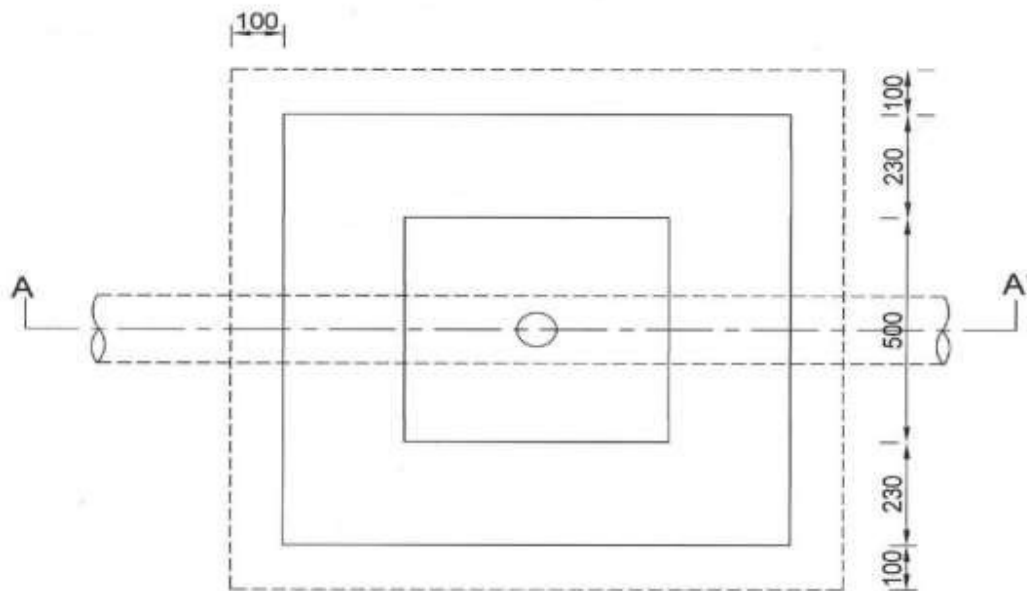
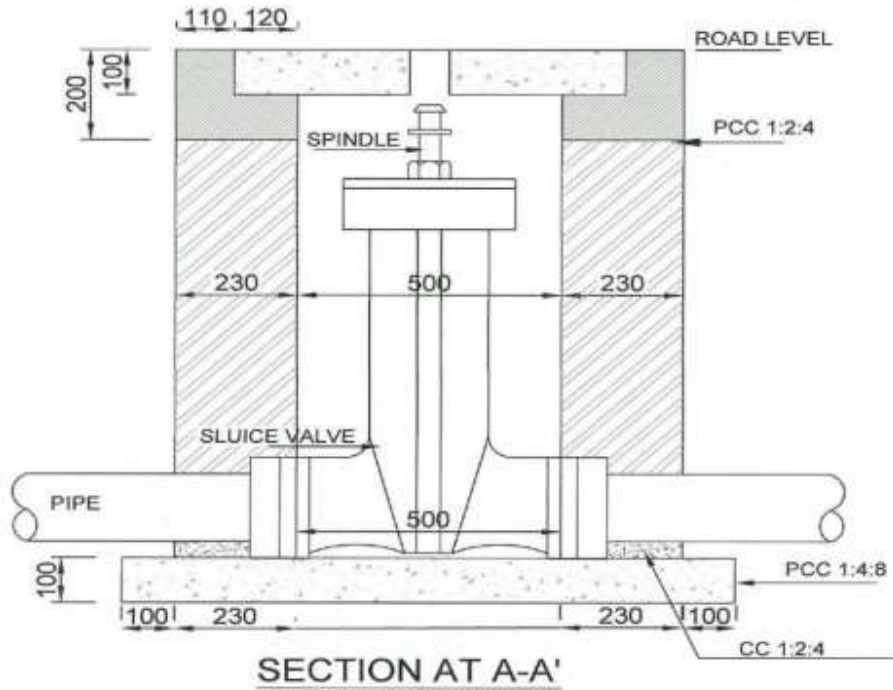

**DRAWING D-4**

**U. P. J A L N I G A M**  
 TYPE DESIGN :  
 MASONARY TYPE SLUICE VALVE CHAMBER

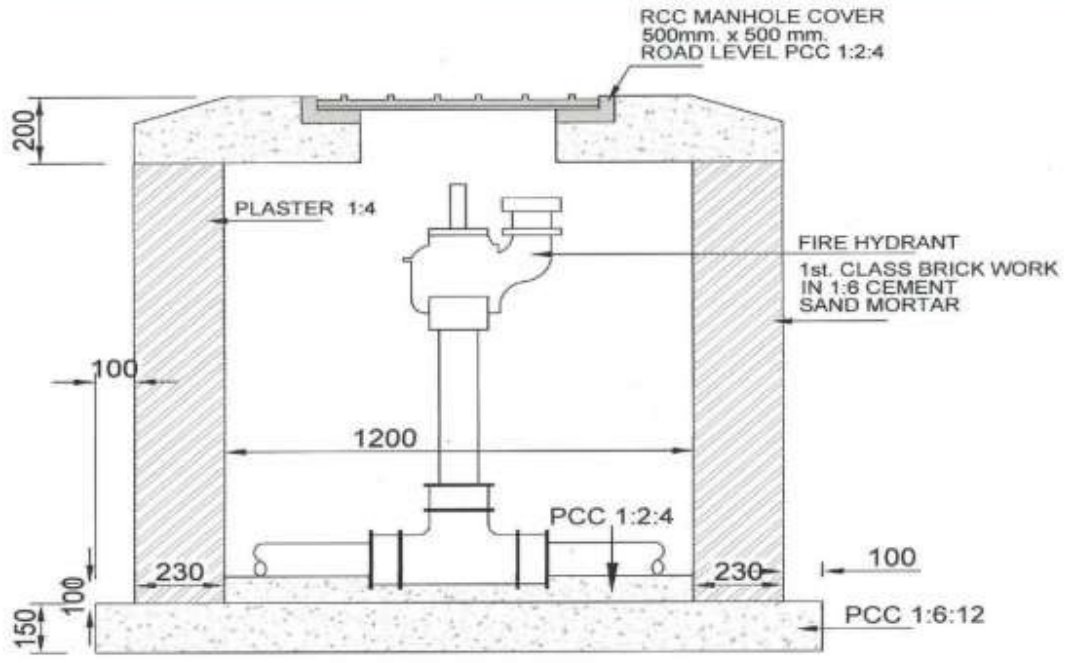

**SECTION AT A-A'**

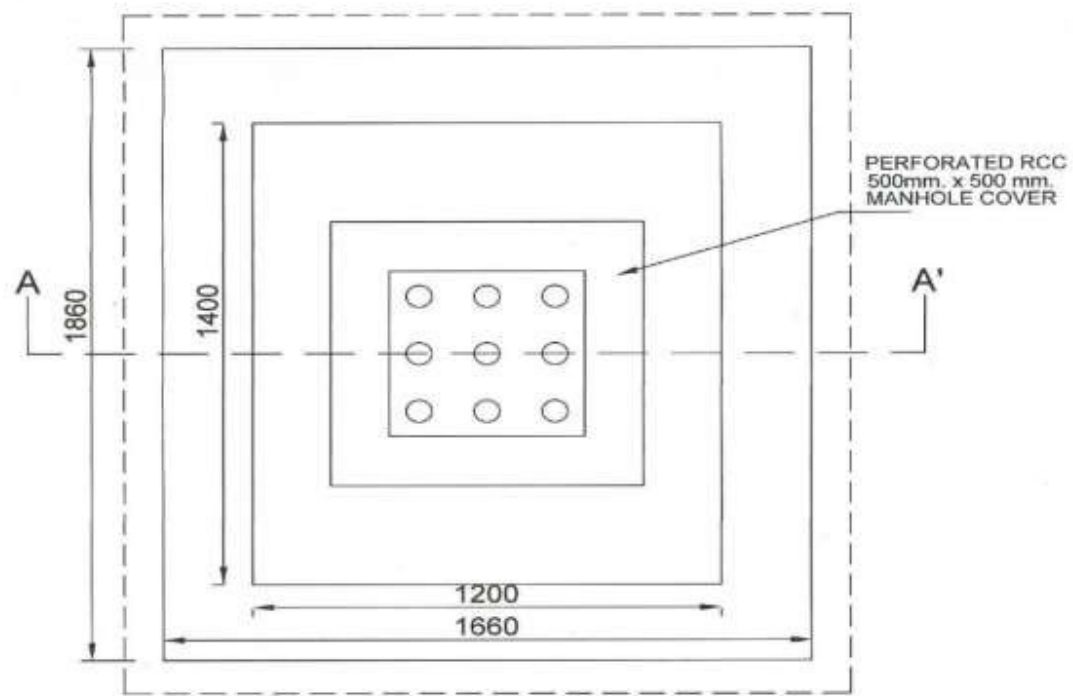

**PLAN**

**DRAWING D-5**

U. P. JAL NIGAM  
TYPE DESIGN :  
CHAMBER FOR FIRE HYDRANT

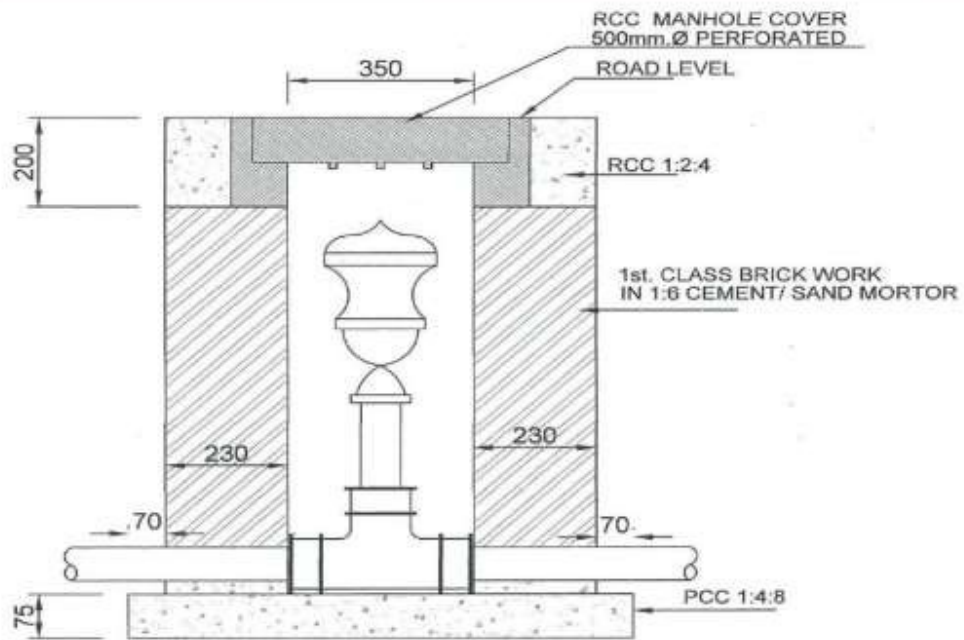

**SECTION AT A-A'**

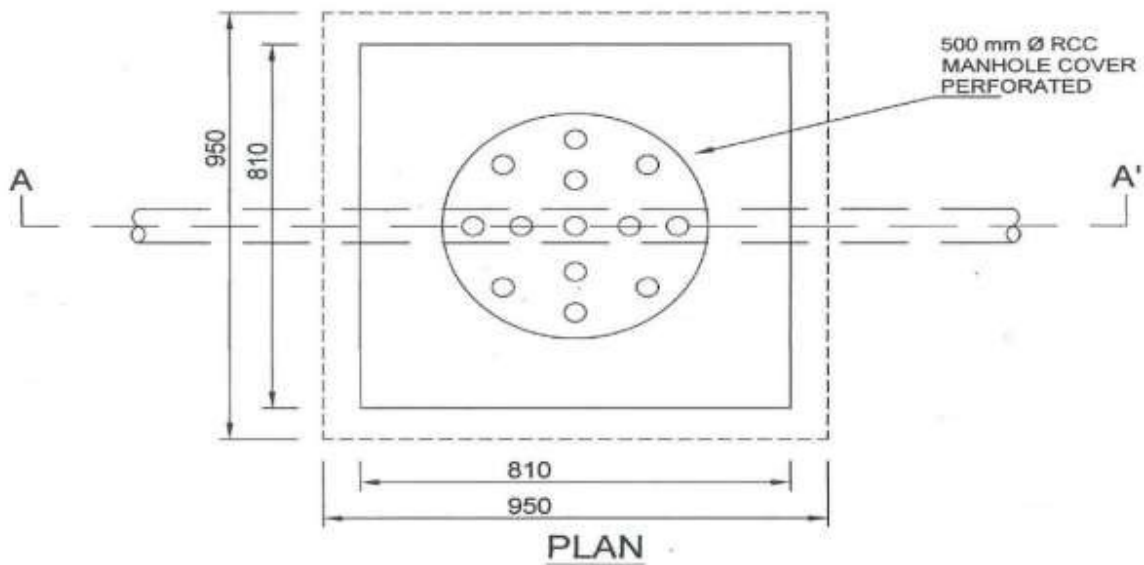

**DRAWING D-6**

**U. P. J A L N I G A M**

**TYPE DESIGN :**

**CHAMBER FOR AIR VALVE**

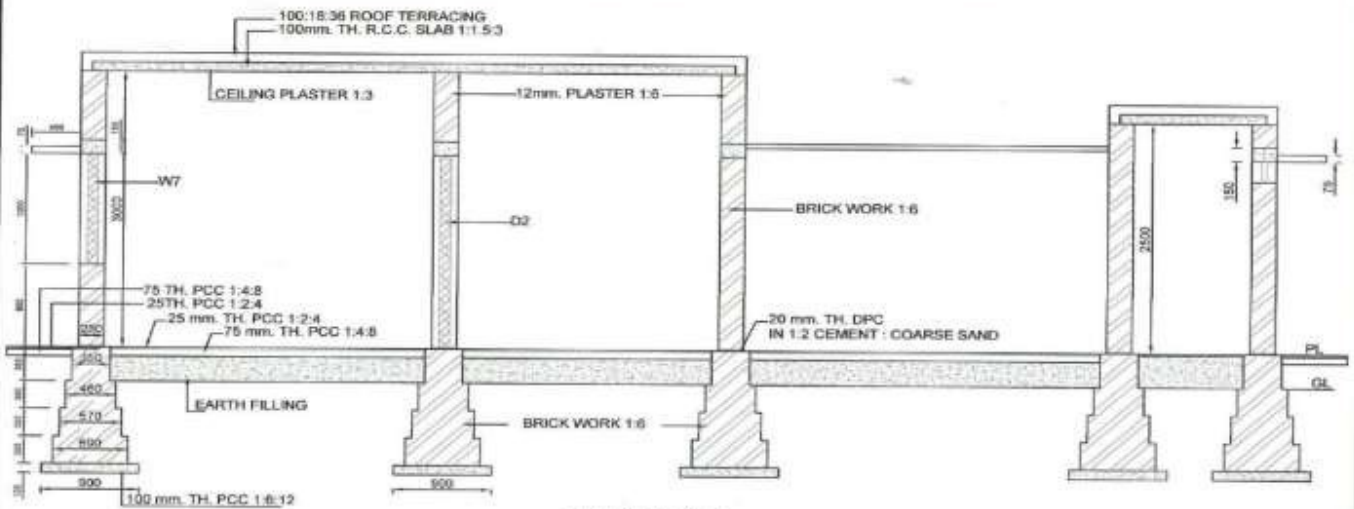

SECTION AT A-B



FRONT ELEVATION



GROUND FLOOR PLAN - STAFF QUARTER

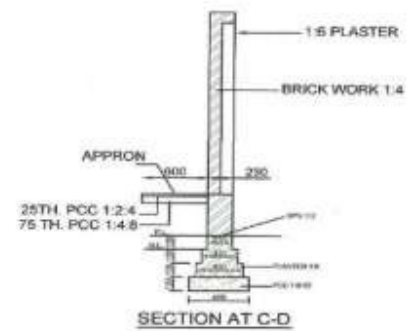

SECTION AT C-D

SCHEDULE OF DOOR WINDOW			
TYPE	WIDTH	HEIGHT	DESCRIPTION
D2	900	2000	SINGLE SHUTTER
D3	900	2000	SINGLE SHUTTER
W6	800	1200	SINGLE SHUTTER
W7	900	1200	SINGLE SHUTTER

NOTES -

1. ALL DIMENSION ARE IN mm.
2. THE DETAIL DRAWING OF ALL R.C.C. WORK SHALL BE PREPARED AT THE TIME OF CONSTRUCTION - FOUNDATION AS PER SITE CONDITION OF SOIL, TO EXAMINE, IN CASE MAKE AMENDMENTS IN STRUCTURAL DETAILS IN CONSULTATION WITH COMPETENT AUTHORITY.
3. ALL WORKS TO BE CARRIED OUT AS PER SCHEDULE SPECIFICATION BRICK WORK IN FOUNDATION IN 1:6.
4. SKIRTING AS SPECIFIED IN ALL ROOM VERANDAH & LAWN ETC. WHERE EVER REQUIRED.
5. SHELVES & ALMARAH TO BE PROVIDE IN CONSULTATION WITH AUTHORITIES CONCERNED BUT TO BE KEPT IN LEVEL OF DOOR & WINDOW.
6. FINISH LEVEL AS PER SITE.
7. FOUNDATION PCC IN 1:4:12.

**DRAWING D-7**

U. P. JAL NIGAM

J.E. A.E. E.E.

# SKETCH SHOWING PIPES / FITTINGS IN R.C.C. OVER HEAD TANK

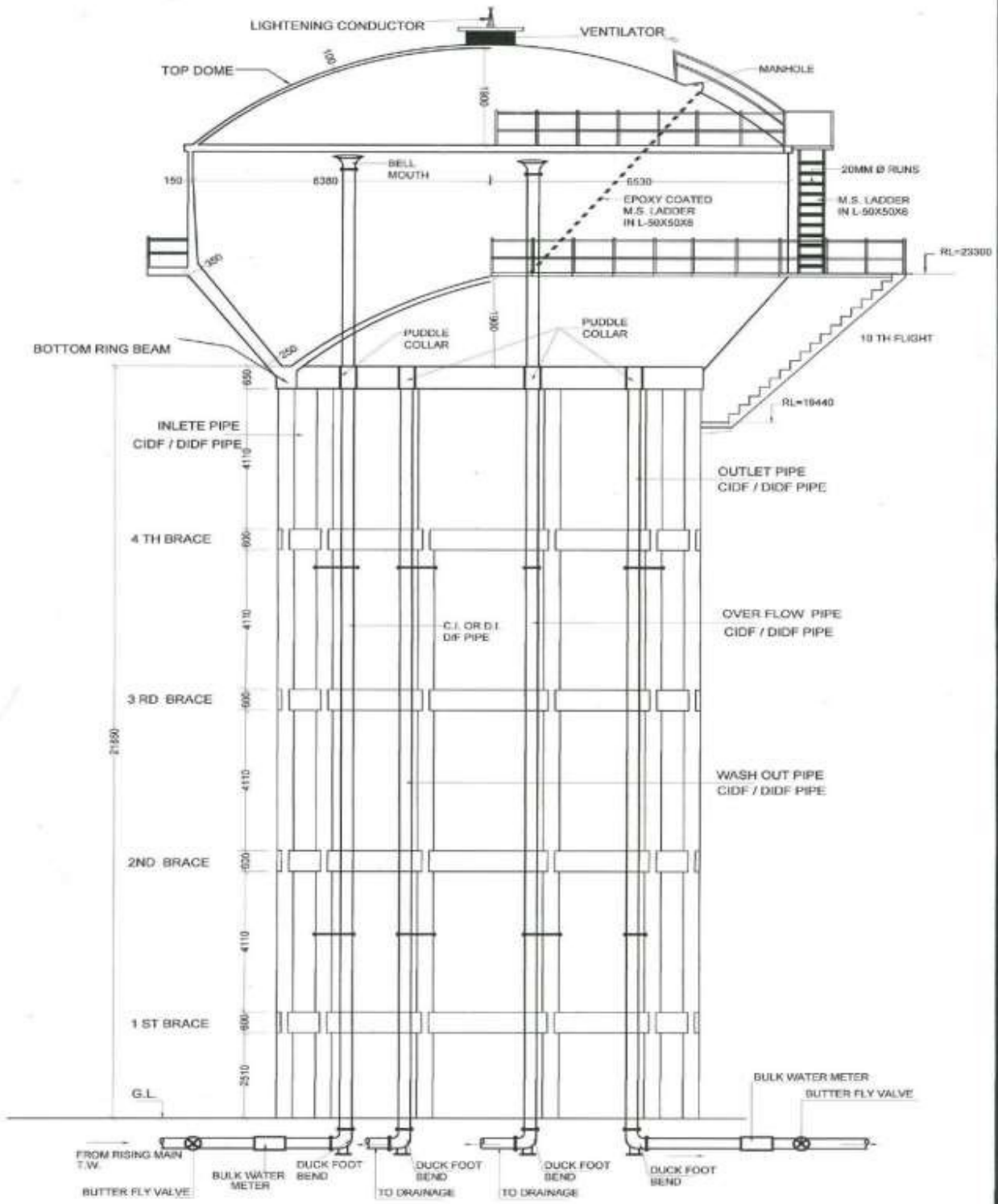

**DRAWING D-8**

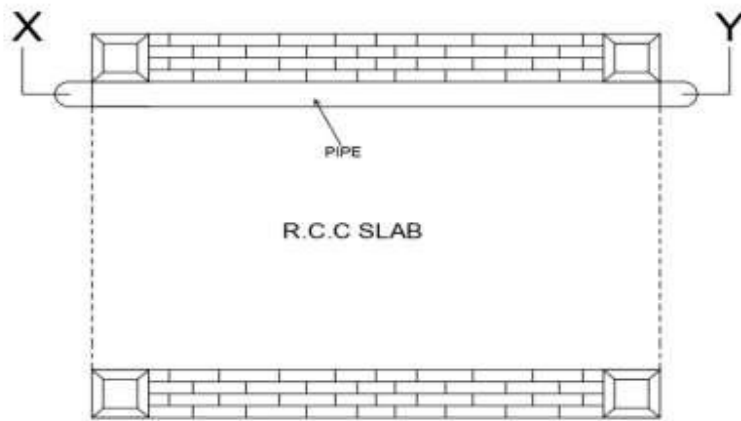

TOP PLAN

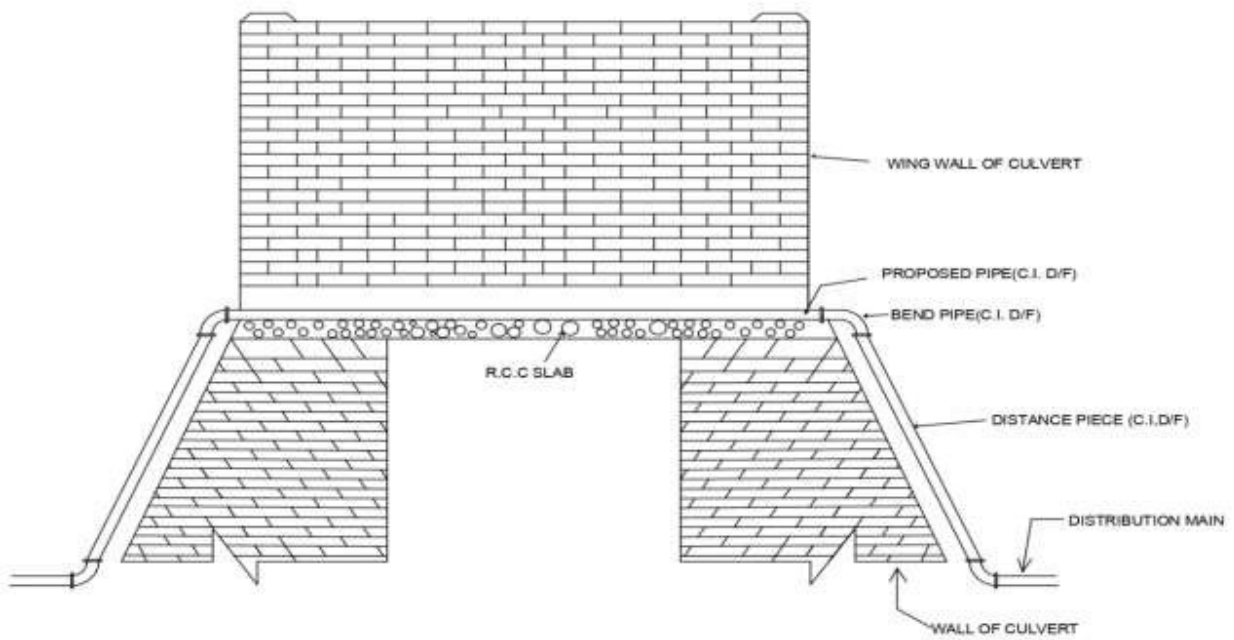

ELEVATION AT X-Y

**DRAWING D-9**

SCALE: 1:10

DRAWING FOR CULVERT CROSSING

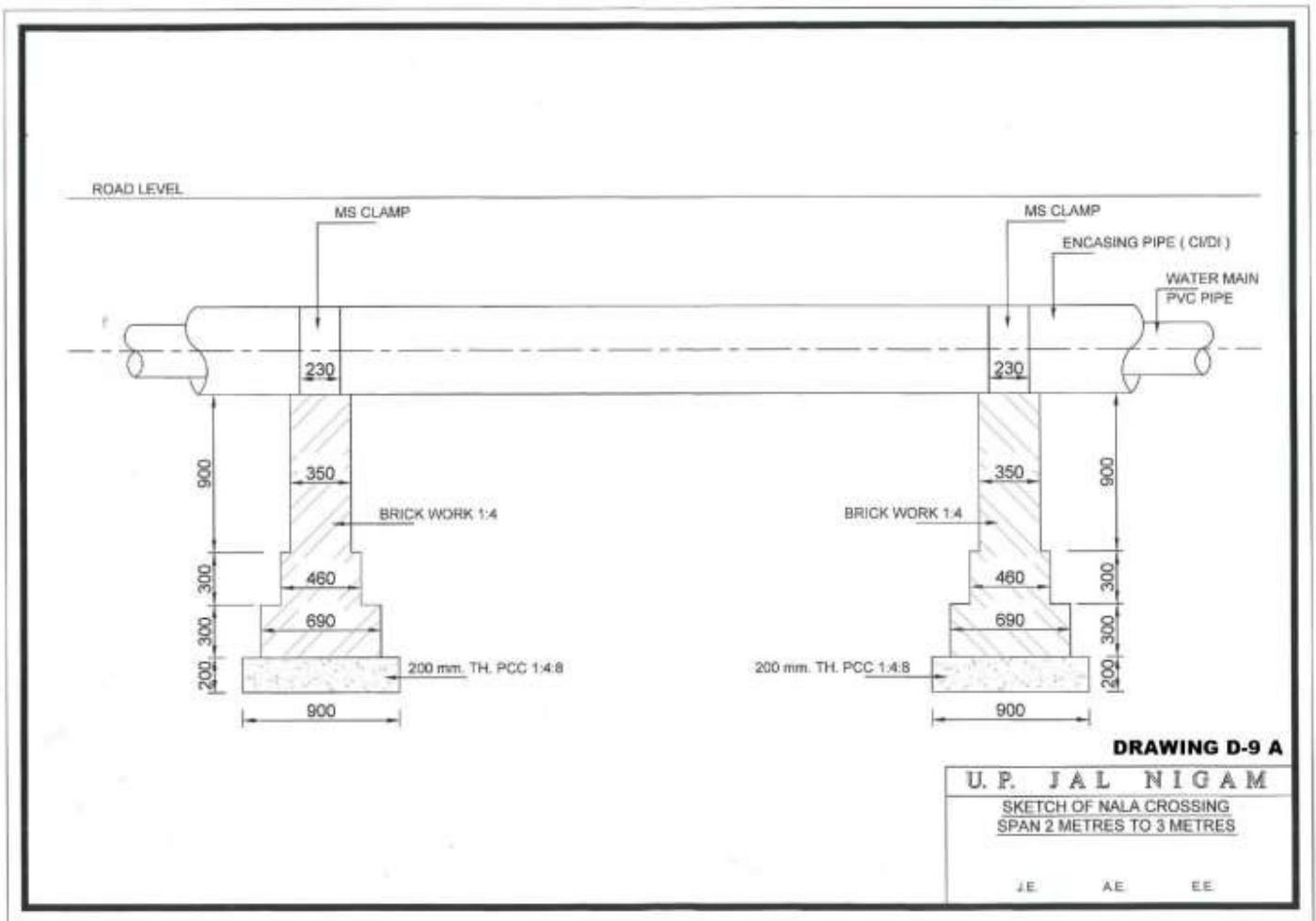

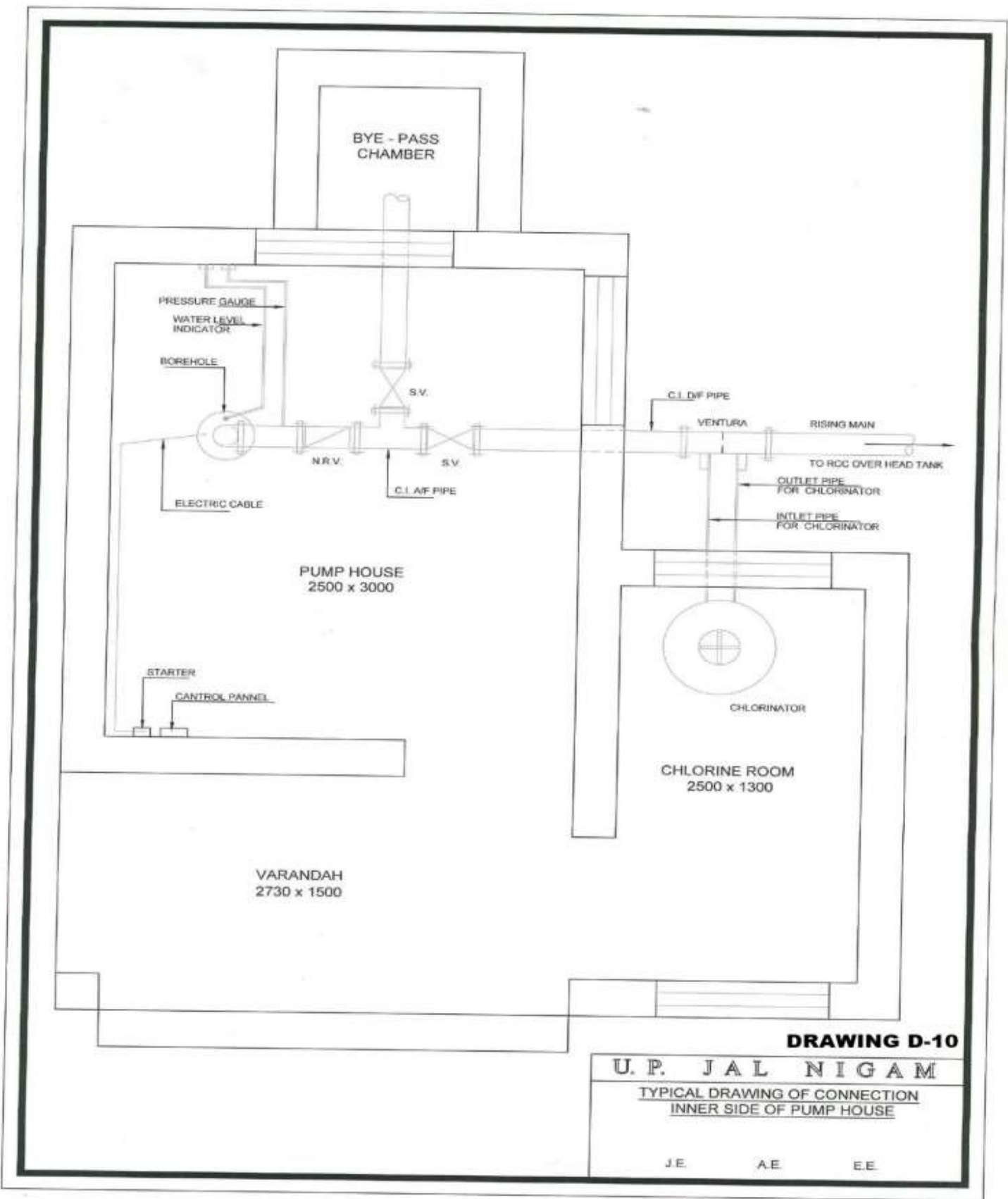

**DRAWING D-10**

**U. P. JAL NIGAM**

TYPICAL DRAWING OF CONNECTION  
INNER SIDE OF PUMP HOUSE

J.E.      A.E.      E.E.

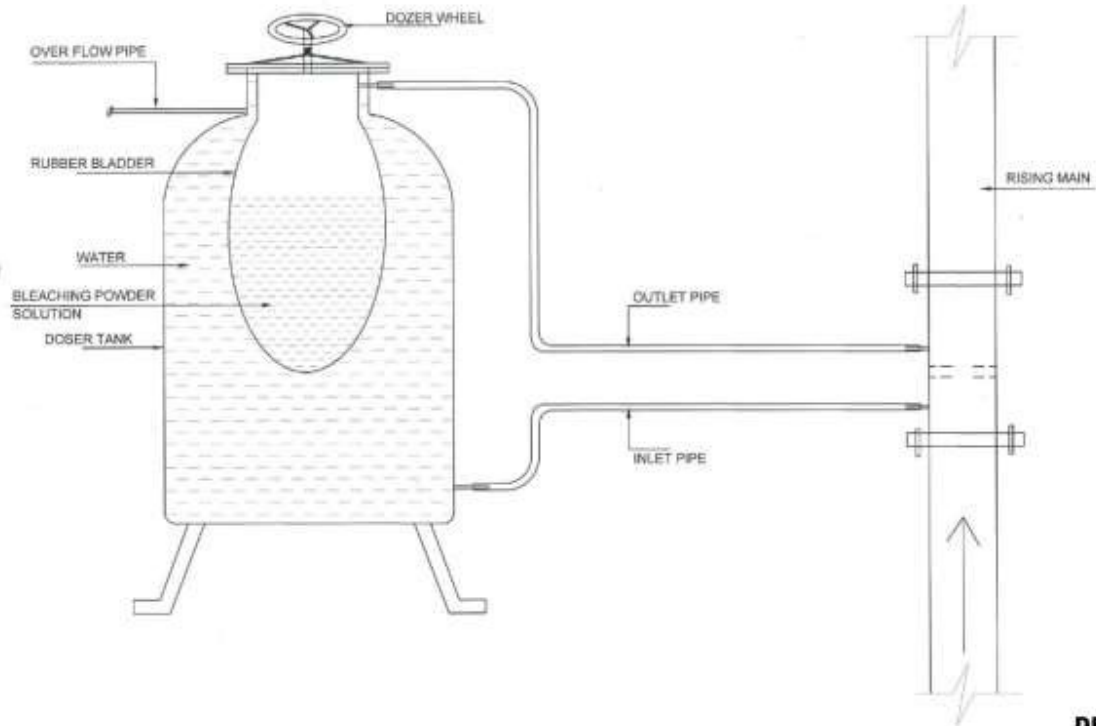

**DRAWING D-11**

**U. P. J A L N I G A M**  
 ELECTRO MECHANICAL TYPE  
 DIFFERENTIAL PRESSUR FEED TYPE DOSER

J E    A E    E E

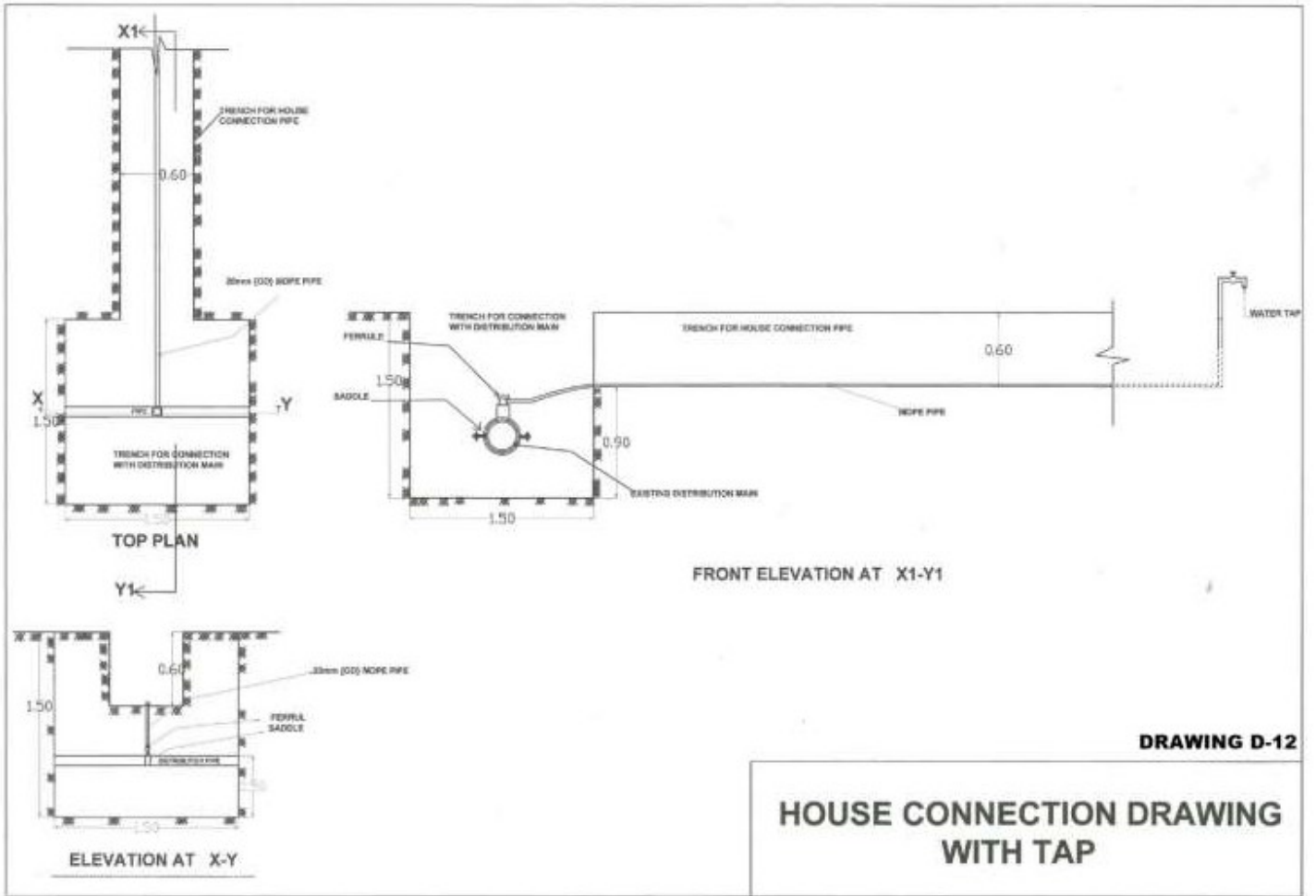

**DRAWING D-12**

**HOUSE CONNECTION DRAWING WITH TAP**

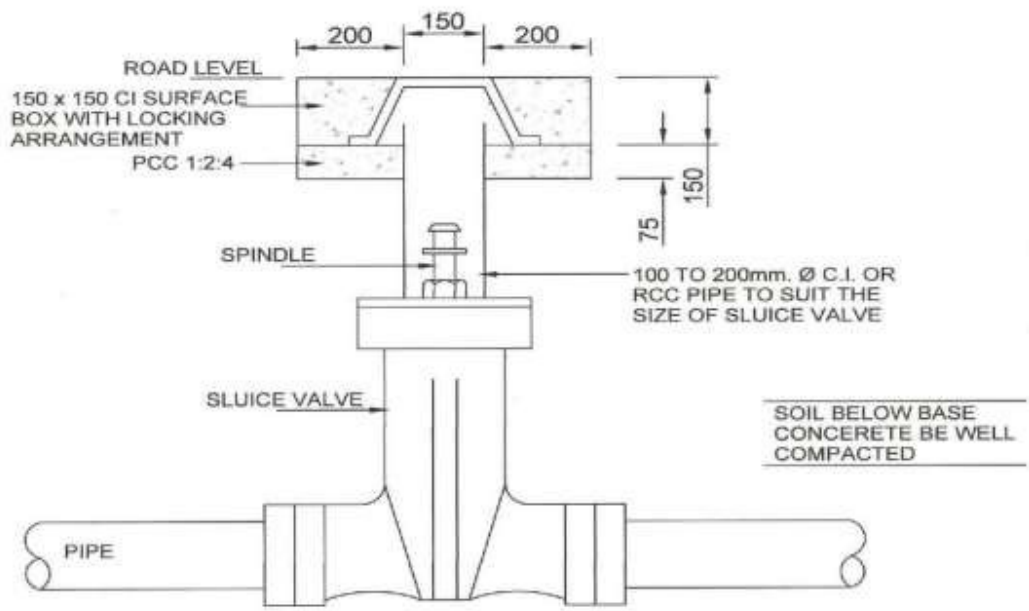

SECTION AT A-A'

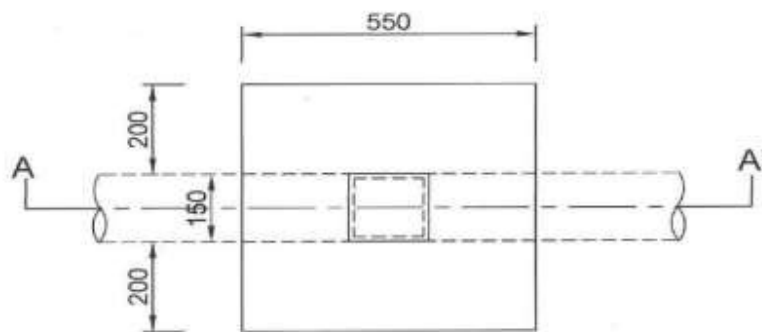

PLAN

**DRAWING D-13**

U. P. J A L N I G A M

TYPE DESIGN :

SURFACE BOX TYPE SLUICE VALVE CHAMBER

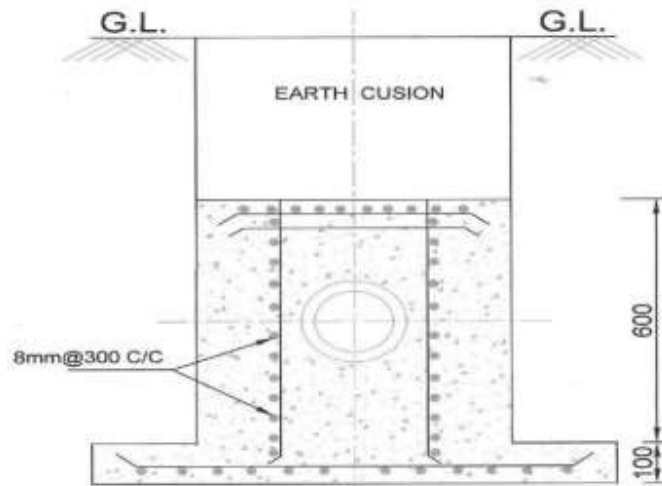

**SECTION AT A-A'**

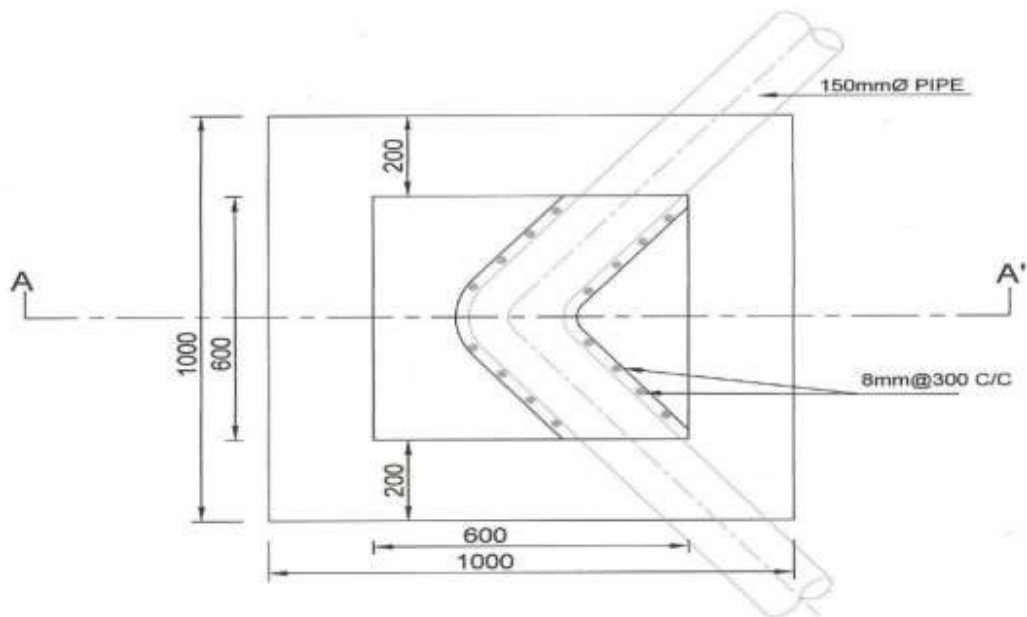

**PLAN**

**DRAWING D-14**

**U. P. JAL NIGAM**

**THRUST BLOCK FOR 45° HORIZONTAL  
BEND 150 mm.Ø PIPE**

J.E

A.E

E.E

OFFICE OF THE EXECUTIVE ENGINEER, CONSTRUCTION DIVISION-I, U.P. JAL NIGAM (URBAN), PRAYAGRAJ

**CROSS SECTION OF HOUSE CONNECTION FOR W/S SCHEME**  
FOR 90 MM AND ABOVE DIA HDPE/PVC/C/CI/DI PIPE

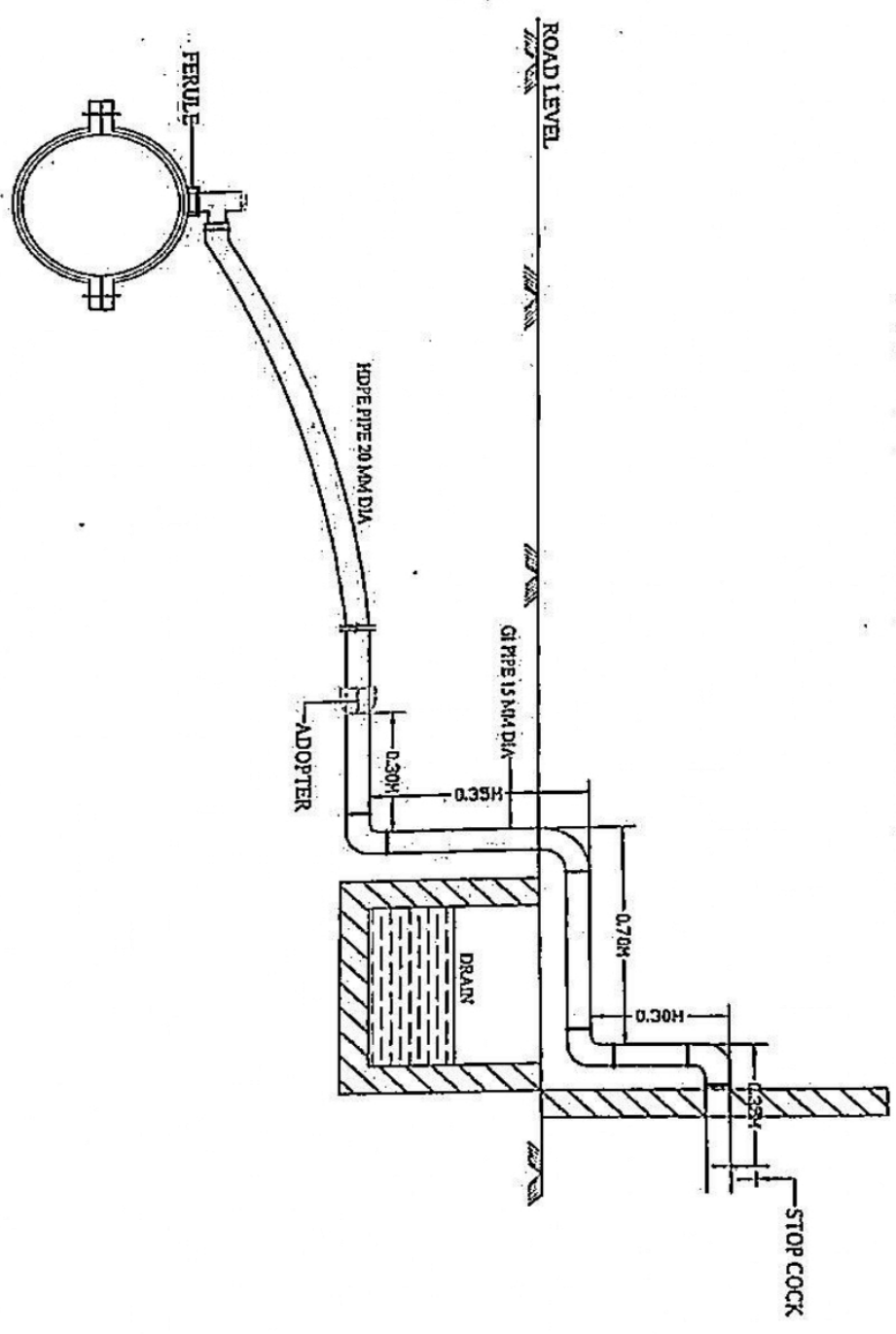

J.E.

*[Handwritten signature]*

*[Handwritten signature]*

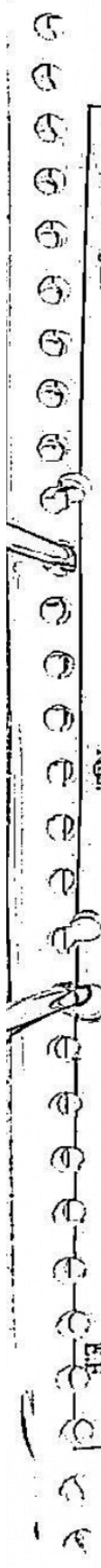

# TYPE DESIGN OF PILLAR & GATE

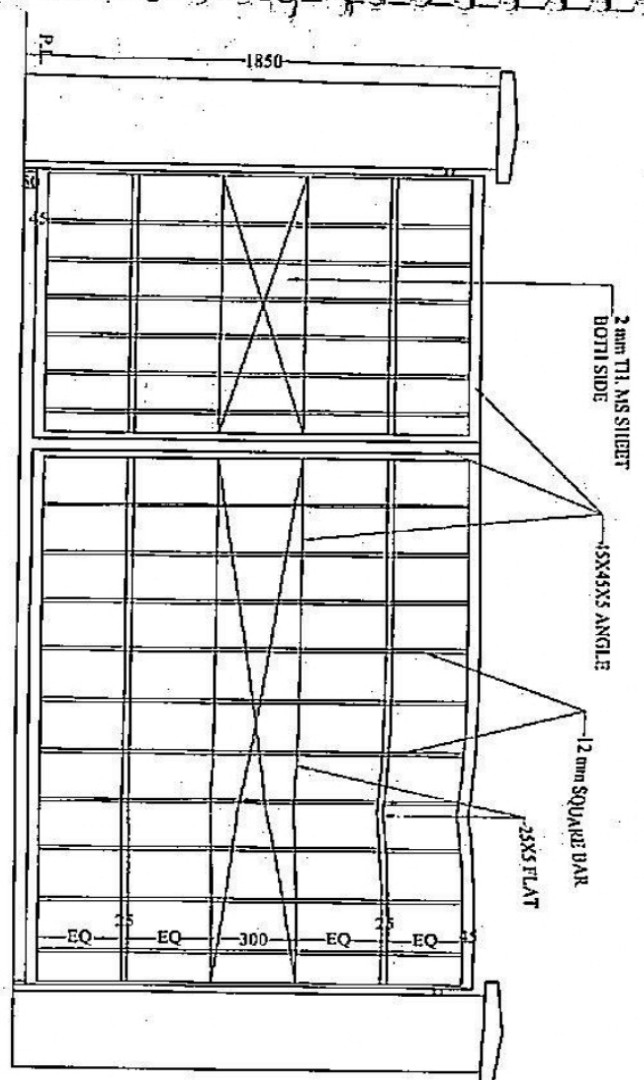

ELEVATION

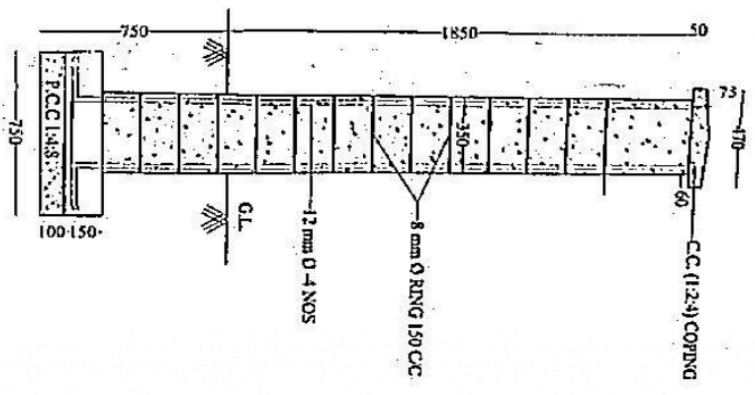
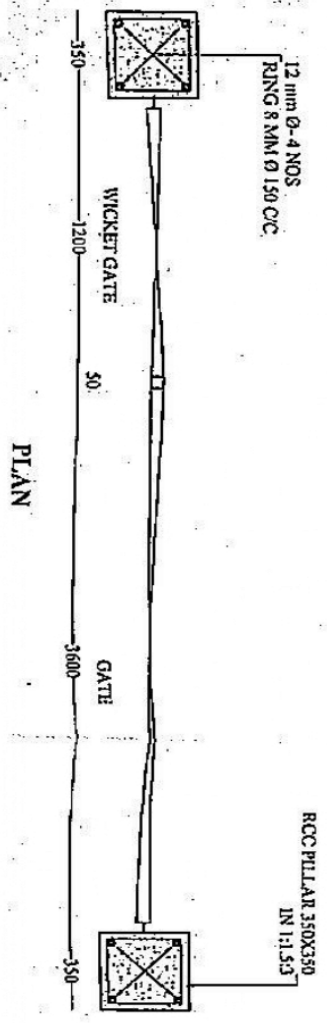

570

OFFICE OF THE EXECUTIVE ENGINEER  
 THE CIVIL SUPPLY DEPARTMENT  
 CHENNAI

DESIGNER OF PILLAR & GATE

11

1	2	3	4	5	6	7	8	9	10	11	12	13	14	15	16	17	18	19	20	21	22
1	2	3	4	5	6	7	8	9	10	11	12	13	14	15	16	17	18	19	20	21	22
1	2	3	4	5	6	7	8	9	10	11	12	13	14	15	16	17	18	19	20	21	22

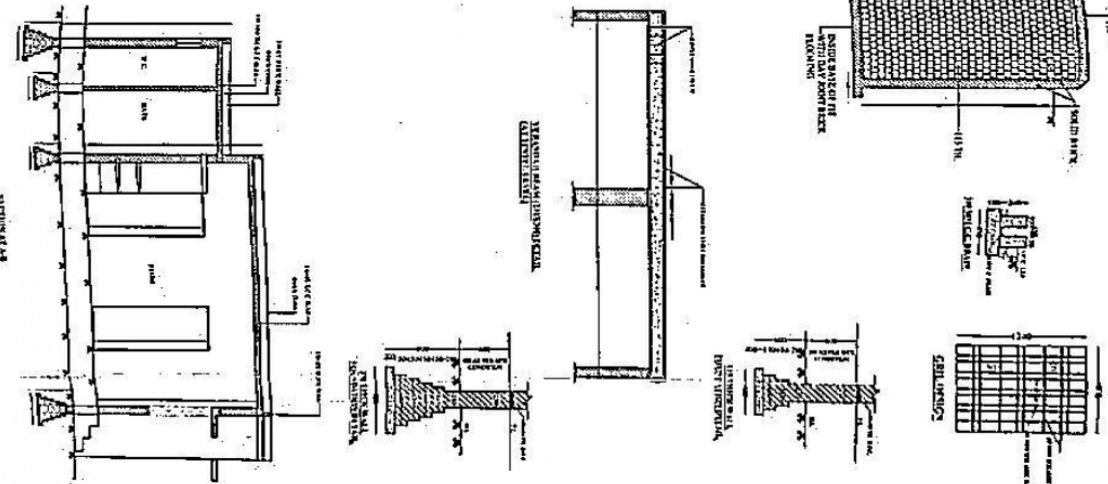
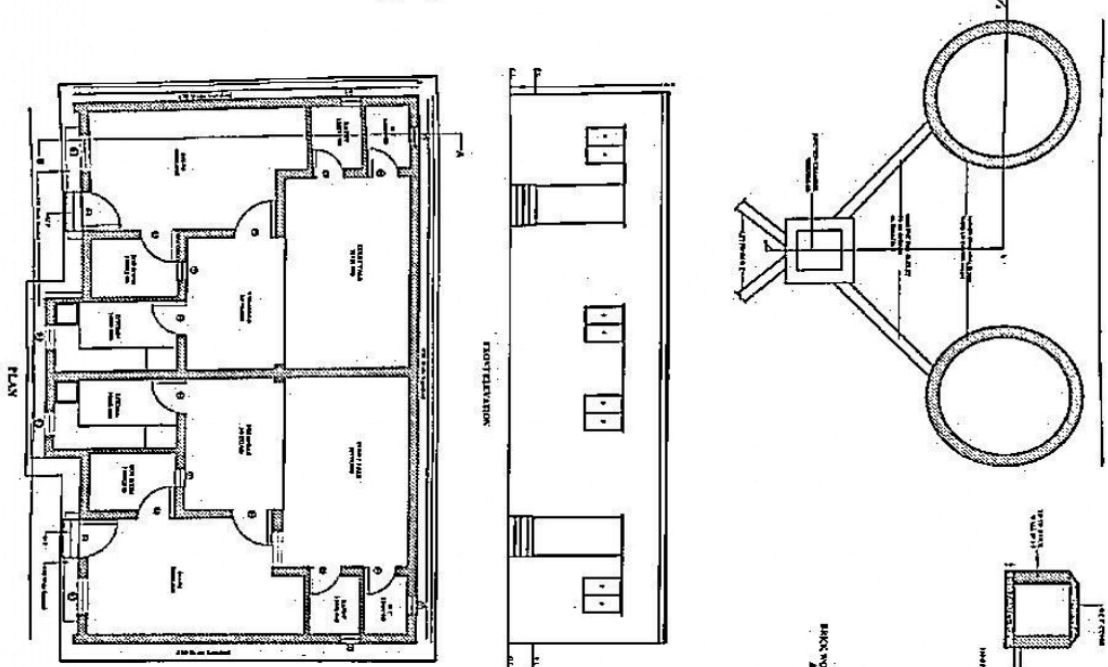

OFFICE OF THE ENGINEERING ASSISTANT  
 OFFICE OF THE ARCHITECT  
 THE ENGINEERING ASSISTANT  
 THE ARCHITECT  
 311

1	2	3	4	5	6	7	8	9	10	11	12	13	14	15	16	17	18	19	20	21	22	23	24	25	26	27	28	29	30	31	32
1	2	3	4	5	6	7	8	9	10	11	12	13	14	15	16	17	18	19	20	21	22	23	24	25	26	27	28	29	30	31	32

# TYPE DESIGN OF PUMP HOUSE CUM CHRONOMIS ROOM

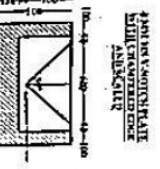

UNIT & VERTICAL DIMENSIONS DETAIL

UNIT	VERTICAL DIMENSION	UNIT	VERTICAL DIMENSION	UNIT	VERTICAL DIMENSION
1	100	2	100	3	100
4	100	5	100	6	100
7	100	8	100	9	100
10	100	11	100	12	100

SLAB REINFORCEMENT DETAIL

NO.	SECTION	REINFORCEMENT	REINFORCEMENT	REINFORCEMENT	REINFORCEMENT
1	1	100	100	100	100
2	2	100	100	100	100
3	3	100	100	100	100
4	4	100	100	100	100
5	5	100	100	100	100

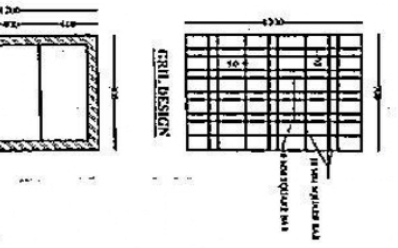
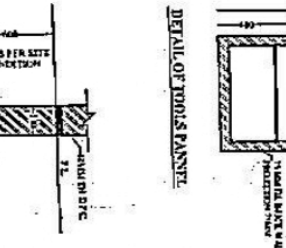
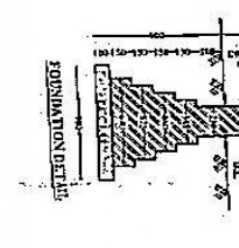
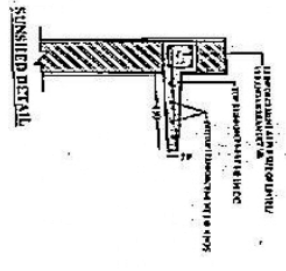
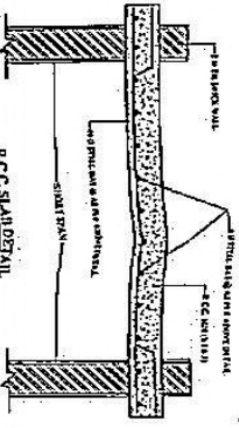
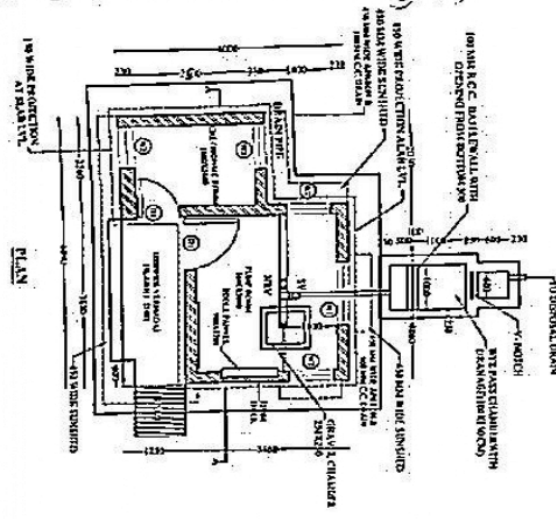
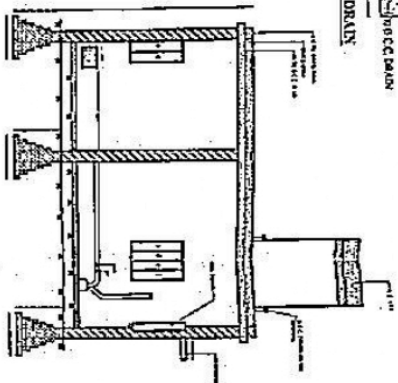
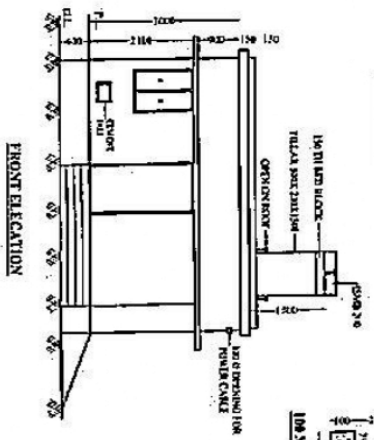

- NOTE -
1. THE DRAWING IS FOR THE TYPE DESIGN AND IS NOT TO BE USED FOR ANY OTHER PURPOSE.
  2. THE DRAWING IS FOR THE TYPE DESIGN AND IS NOT TO BE USED FOR ANY OTHER PURPOSE.
  3. THE DRAWING IS FOR THE TYPE DESIGN AND IS NOT TO BE USED FOR ANY OTHER PURPOSE.
  4. THE DRAWING IS FOR THE TYPE DESIGN AND IS NOT TO BE USED FOR ANY OTHER PURPOSE.
  5. THE DRAWING IS FOR THE TYPE DESIGN AND IS NOT TO BE USED FOR ANY OTHER PURPOSE.
  6. THE DRAWING IS FOR THE TYPE DESIGN AND IS NOT TO BE USED FOR ANY OTHER PURPOSE.
  7. THE DRAWING IS FOR THE TYPE DESIGN AND IS NOT TO BE USED FOR ANY OTHER PURPOSE.
  8. THE DRAWING IS FOR THE TYPE DESIGN AND IS NOT TO BE USED FOR ANY OTHER PURPOSE.
  9. THE DRAWING IS FOR THE TYPE DESIGN AND IS NOT TO BE USED FOR ANY OTHER PURPOSE.
  10. THE DRAWING IS FOR THE TYPE DESIGN AND IS NOT TO BE USED FOR ANY OTHER PURPOSE.
  11. THE DRAWING IS FOR THE TYPE DESIGN AND IS NOT TO BE USED FOR ANY OTHER PURPOSE.
  12. THE DRAWING IS FOR THE TYPE DESIGN AND IS NOT TO BE USED FOR ANY OTHER PURPOSE.
  13. THE DRAWING IS FOR THE TYPE DESIGN AND IS NOT TO BE USED FOR ANY OTHER PURPOSE.
  14. THE DRAWING IS FOR THE TYPE DESIGN AND IS NOT TO BE USED FOR ANY OTHER PURPOSE.
  15. THE DRAWING IS FOR THE TYPE DESIGN AND IS NOT TO BE USED FOR ANY OTHER PURPOSE.
  16. THE DRAWING IS FOR THE TYPE DESIGN AND IS NOT TO BE USED FOR ANY OTHER PURPOSE.
  17. THE DRAWING IS FOR THE TYPE DESIGN AND IS NOT TO BE USED FOR ANY OTHER PURPOSE.
  18. THE DRAWING IS FOR THE TYPE DESIGN AND IS NOT TO BE USED FOR ANY OTHER PURPOSE.
  19. THE DRAWING IS FOR THE TYPE DESIGN AND IS NOT TO BE USED FOR ANY OTHER PURPOSE.
  20. THE DRAWING IS FOR THE TYPE DESIGN AND IS NOT TO BE USED FOR ANY OTHER PURPOSE.
  21. THE DRAWING IS FOR THE TYPE DESIGN AND IS NOT TO BE USED FOR ANY OTHER PURPOSE.
  22. THE DRAWING IS FOR THE TYPE DESIGN AND IS NOT TO BE USED FOR ANY OTHER PURPOSE.
  23. THE DRAWING IS FOR THE TYPE DESIGN AND IS NOT TO BE USED FOR ANY OTHER PURPOSE.
  24. THE DRAWING IS FOR THE TYPE DESIGN AND IS NOT TO BE USED FOR ANY OTHER PURPOSE.
  25. THE DRAWING IS FOR THE TYPE DESIGN AND IS NOT TO BE USED FOR ANY OTHER PURPOSE.
  26. THE DRAWING IS FOR THE TYPE DESIGN AND IS NOT TO BE USED FOR ANY OTHER PURPOSE.

OFFICE OF THE ENGINEER IN-CHARGE  
CIVIL ENGINEERING DEPARTMENT  
PUNJAB  
LUDHIANA

DATE: 10/10/1950

SCALE: 1/4" = 1'-0"

PROJECT: PUMP HOUSE CUM CHRONOMIS ROOM

NO. 100

26	27	28	29	30	31	32	33	34	35	36	37	38	39	40	41	42	43	44	45	46	47	48	49	50	51	52	53	54	55	56	57	58	59	60
----	----	----	----	----	----	----	----	----	----	----	----	----	----	----	----	----	----	----	----	----	----	----	----	----	----	----	----	----	----	----	----	----	----	----

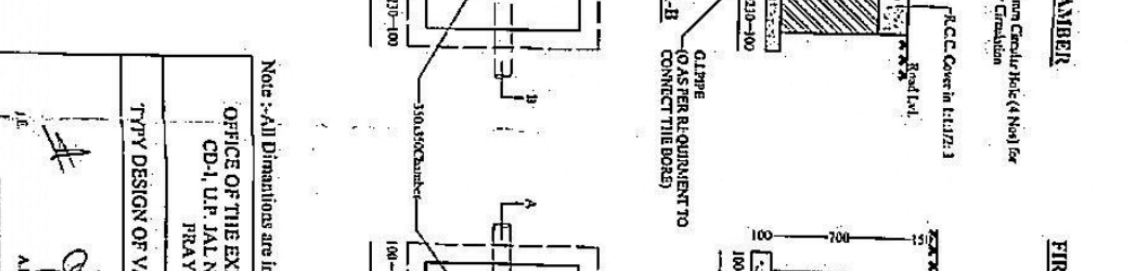
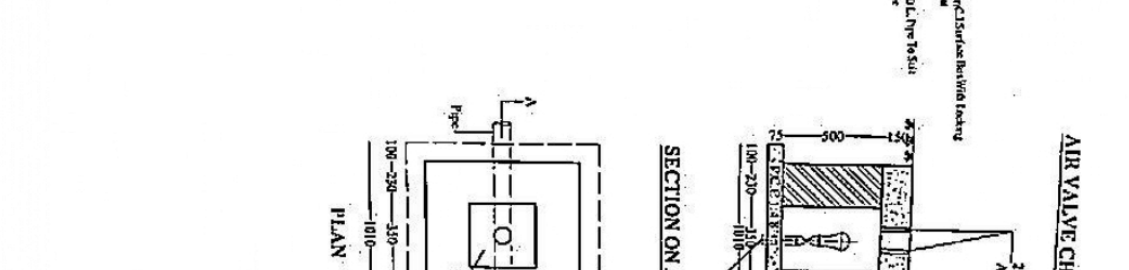
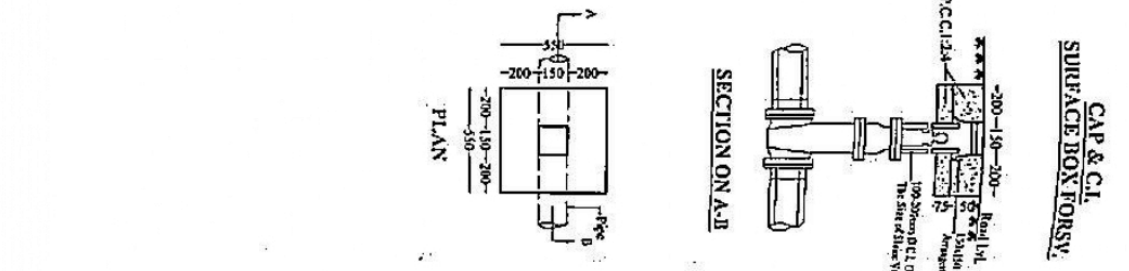
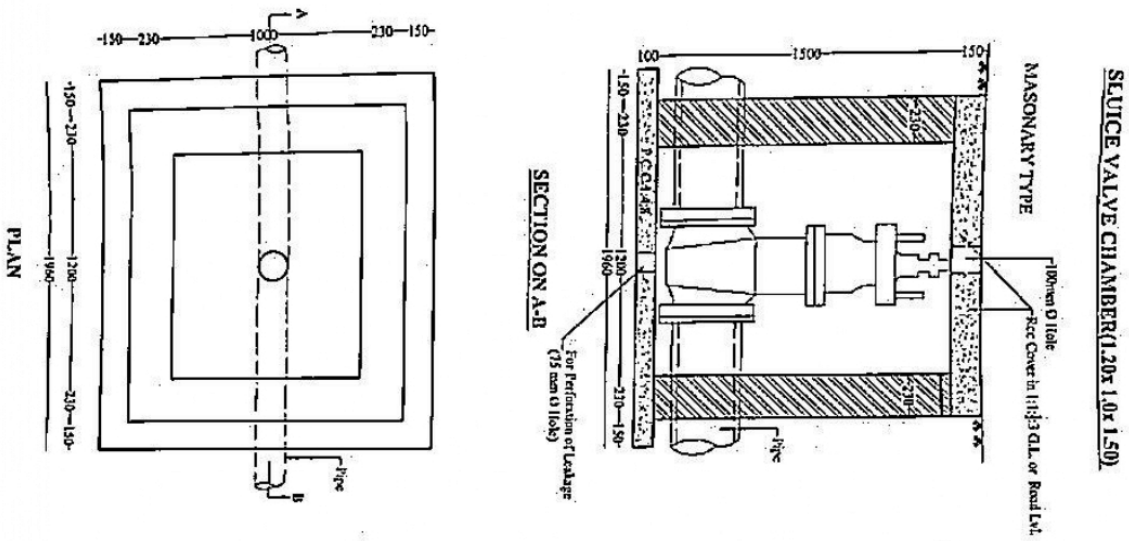

Note :- All Dimensions are in mm

OFFICE OF THE EXECUTIVE ENGINEER CD-1, U.P. JAL NIGAM (URBAN), PRAVAGRAJ	
TYPY DESIGN OF VARIOUS CHAMBERS	321
CONSTRUCTION DIVISION, U.P. Jal Nigam (Urban) Prayagraj	

**BOUNDARY WALL**

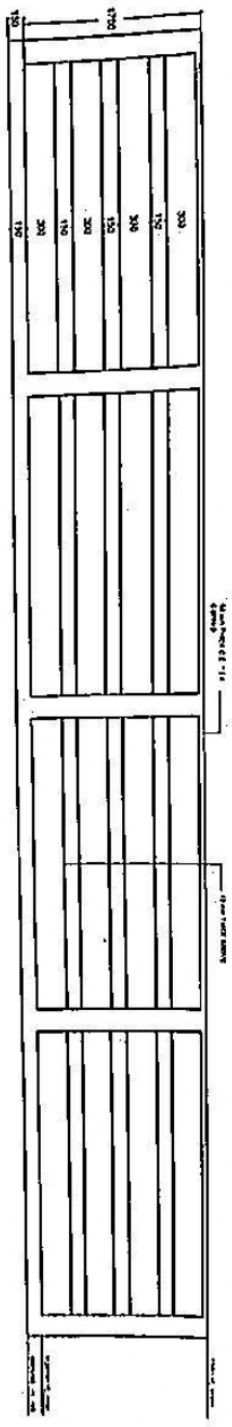

**FRONT ELEVATION**

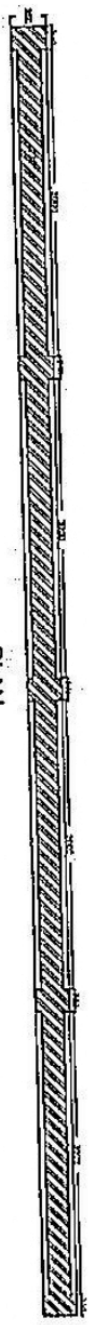

**PLAN**

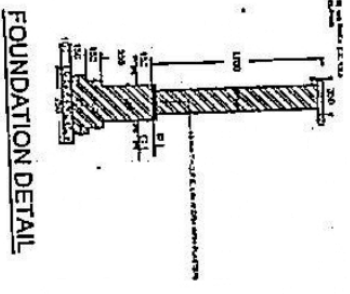

213

\* EXPANSION JOINT SHOULD BE PROVIDED AT EVERY 300 U.L. LENGTH.  
NOTE: ALL DIMENSIONS ARE IN M.M.

OFFICE OF THE EXECUTIVE ENGINEER  
CONSTRUCTION DIVISION-I  
UP JAL NIGAM (URBAN), PRAYAGRAJ (U.P.)



TYPE DESIGN OF BOUNDARY WALL

*[Signature]*  
*[Signature]*  
*[Signature]*

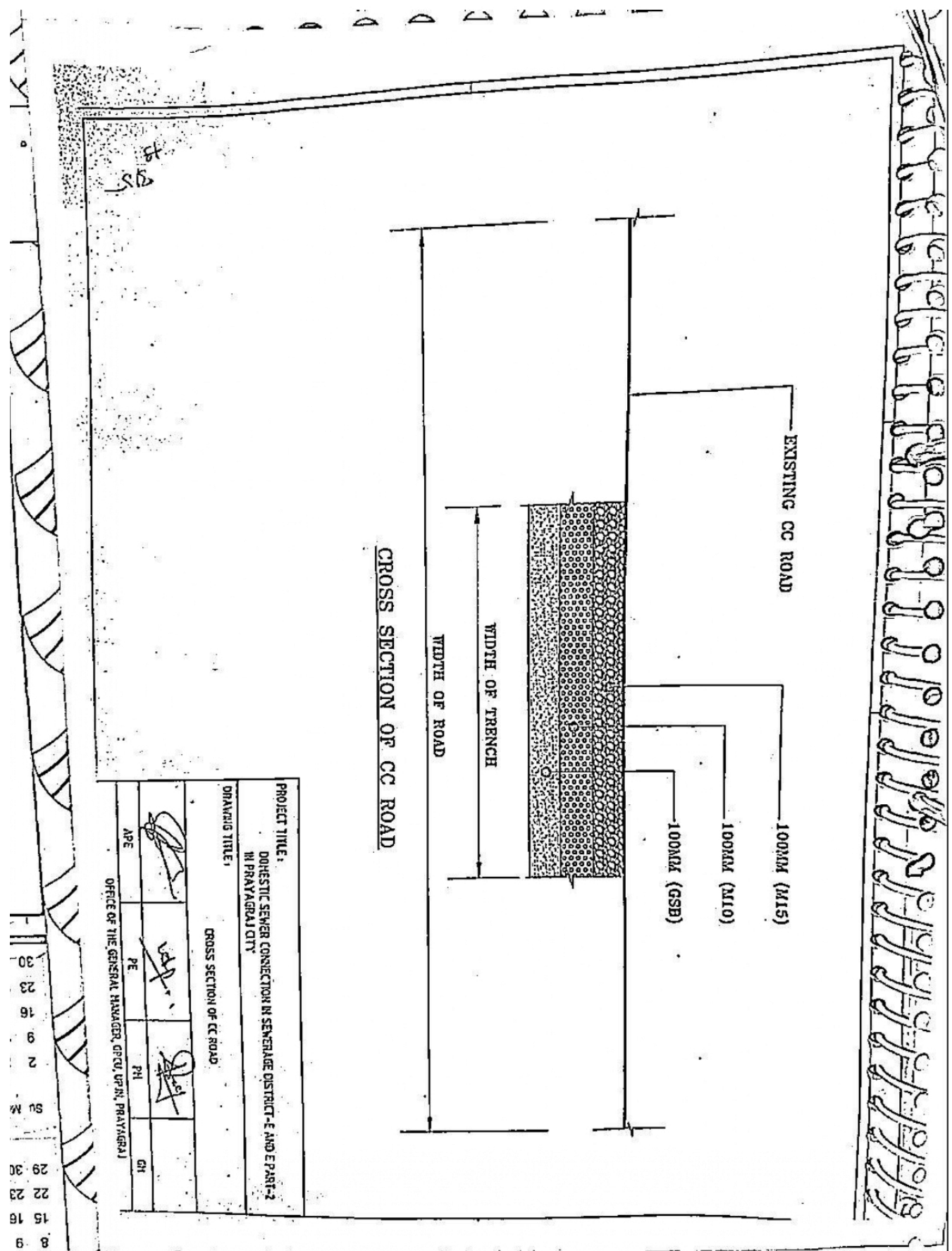
6 2 2 1 1 8 1 5

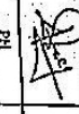

**CROSS SECTION OF CC ROAD**

<b>PROJECT TITLE:</b> DOMESTIC SEWER CONNECTION IN SENEHAJE DISTRICT - E AND PART-2 IN PRAYAGRAJ CITY			
<b>DRAWING TITLE:</b> CROSS SECTION OF CC ROAD			
APE 	PE 	PH 	GN 
OFFICE OF THE GENERAL MANAGER, DPCU, UPRI, PRAYAGRAJ			

8	9	15	16	22	23	29	30
---	---	----	----	----	----	----	----

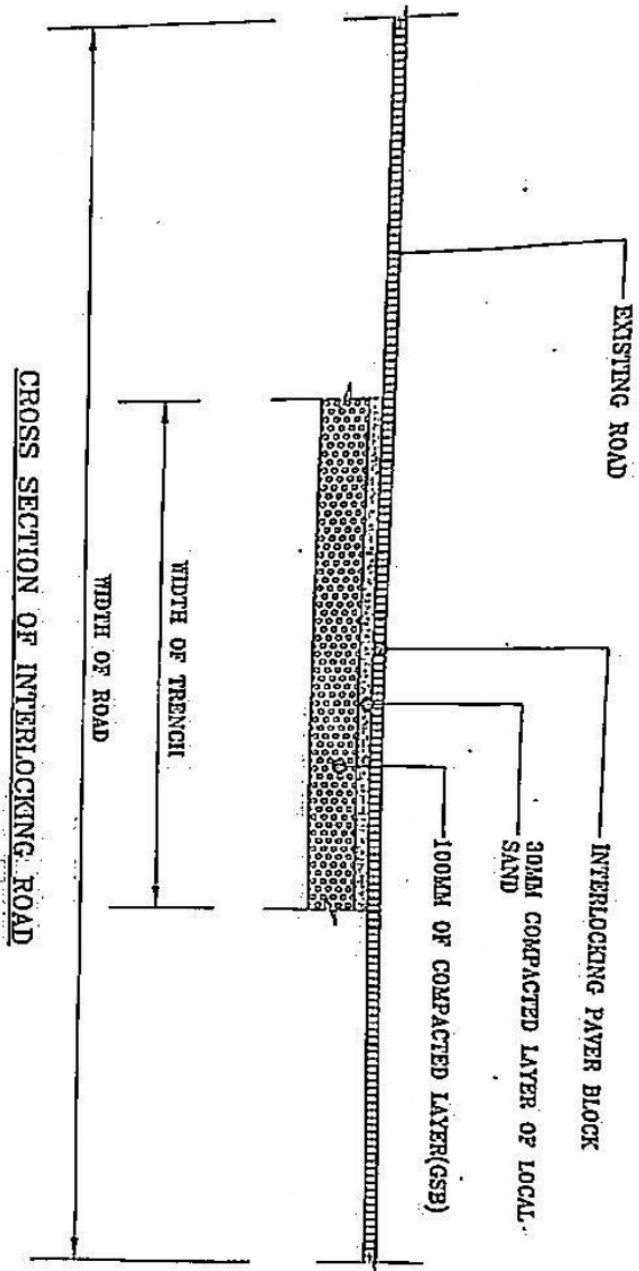

CROSS SECTION OF INTERLOCKING ROAD

218

PROJECT TITLE:  
DOMESTIC SEWER CONNECTION IN SEWERAGE DISTRICT - E AND E PART-2  
IN PRAVARRAJ CITY

DRAWING TITLE:  
CROSS SECTION OF INTERLOCKING ROAD

DATE	PE	PH	GM
<i>[Signature]</i>	<i>[Signature]</i>	<i>[Signature]</i>	

OFFICE OF THE GENERAL MANAGER, GPCU, UPAN, PRAVARRAJ

30	23	16	9	2	50	29	22	15	8	1	50
2	1	1	1	1	Ms	30	22	15	8	1	Ms

SEAL COAT

20MM THICK COMPACTED OPEN GRADED PREMIX CARPET

75MM COMPACTED LAYER OF WBM GRADE-3

150MM COMPACTED LAYER OF WBM GRADE-2

PROVIDING & LAYING 125MM COMPACTED LAYER OF WBM GRADE-1

PROVIDING & LAYING 150MM COMPACTED LAYER OF LOCAL SAND.

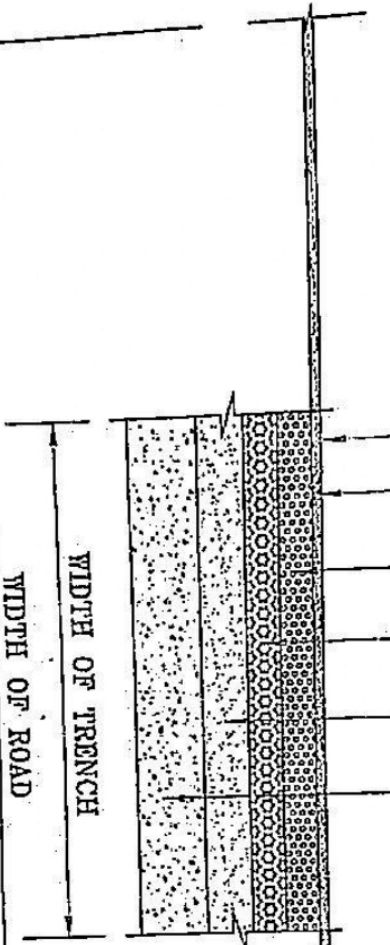

**CROSS SECTION OF ROAD TYPE-B**

PROJECT TITLE: DOMESTIC SEWER CONNECTION IN SEWERAGE DISTRICT-E AND E PART-2 IN PRAYAGRAJ CITY

DRAWING TITLE: CROSS SECTION OF ROAD TYPE-B CLASS

APR	PE	PH	GM
<i>[Signature]</i>	<i>[Signature]</i>	<i>[Signature]</i>	

OFFICE OF THE GENERAL MANAGER, GPCD, U.P.J.K. PRAVRAJ

30	23	24	16	17	9	10	2	3	SU No
1	2	3	8	9	11	15	16	1	22
29	30	2	22	23	2	15	16	1	29