

**Government of India,
Sashastra Seema Bal (MHA),
O/o the Dy. Inspector General,
Sector Headquarters, SSB, Purnea,
Kala Bhawan Road, DRDA Building.
Purnea (Bihar)**

NIT No.-EE/SHQP/31/2025-26

**Name of Work : Construction of Indo-Nepal Border pillars
of 18 Bn Rajnagar, 45 Bn Birpur, 56
Bathnaha & 52 Bn Araria under SHQ SSB
Purnea.**

Estimate Cost : Rs. 46,35,288/-

Period of Completion : 180 Days

Index

Sl. No.	Description	Page No.
1.	Index	2
2.	Notice Inviting e-Tender	3
3.	Part-A (General Information)	
3.1	Information and instructions for Bidders for e-tendering	4-9
3.2	CPWD-6 for e-Tendering	10-14
3.3	CPWD-7	15-16
3.4	Acceptance	17
3.5	Proforma of Schedules A to F (Civil & Electrical)	18-23
3.6	Receipt of EMD deposition and site visit	24-25
3.7	Various Forms (B, B-1, E & F)	26-28
3.8	Affidavit regarding details of work for similar nature of works	29
3.9	Under taking regarding GST registration	30
3.11	Field Testing Equipment and Instruments as per Annexure-I, List of Machinery, Tools & Plants as per Annexure -II,	31-32
3.12	Guarantee Bond to be executed by contractors for removal of defects after completion in respect of water proofing works (Annexure -III)	33-34
4	Part-B (Civil Work)	35
4.1	List of approved makes- For Civil Works	36
5	Part-C:	37
5.1	Drawings	38-41
5.2	Schedule of Quantities (Civil)	42-45

Note:-It is certified that this document contains four parts i.e. Part A, Part B, & Part C containing page Nos. 1 to 45

Government of India,
Sashastra Seema Bal (MHA),
O/o the Dy. Inspector General,
Sector Headquarters, SSB, Purnea,
Kala Bhawan Road, DRDA Building, Purnea (Bihar).

Notice Inviting e-Tender

Online Percentage rate bids are invited on behalf of President of India from approved and eligible contractors of CPWD and those of appropriate list of M.E.S., BSNL, Railway and Bihar state P.W.D/Building construction Department in two bid system for the following work(s):-

NITNo. – EE/SHQP/31/2025-26

Sl. No.	Name of Work	Estimated Cost put to Tender	Amount of Earnest Money	Period of Completion
1.	Construction of Indo-Nepal Border pillars of 18 Bn Rajnagar, 45 Bn Birpur, 56 Bathnaha & 52 Bn Araria under SHQ SSB Purnea.	Rs. 46,35,288/-	Rs. 92,706/-	180 days

CRITICAL DATE SHEET:-

NIT Publish date & time	13/05/2026 at 1000 Hrs
Document download start date & time	13/05/2026 at 1000 Hrs
Clarification Start date & time	13/05/2026 at 1000 Hrs
Clarification end date & time	14/05/2026 up to 1200 Hrs
Pre bid conference	14/05/2026 at 1200 Hrs
Tender submission start date & time	13/05/2026 from 1000 Hrs
Tender submission closing date & time	20/05/2026 up to 1500 Hrs
Last date and time for submission of Original EMD and other documents as specified in the NIT	20/05/2026 up to 1200 Hrs
Tender opening date & time	21/05/2026 after 1600 Hrs

All relevant details like, specifications/qualitative requirement etc. Terms & Conditions are available on the www.eprocure.gov.in and www.ssb.nic.in. All tenderers are requested to visit websites regularly to check changes, if any, in the Tender document. No separate communication will be made. Tenderer must ensure up-loading of Legible Documents.

12/5/26
Deputy Comdt. (Engineer)
SHQ, SSB, Purnea

PART - A

GENERAL INFORMATION

INFORMATION AND INSTRUCTIONS FOR BIDDERS FOR e-TENDERING FORMING PART OF BID DOCUMENT

The Deputy Commandant (Engineer), Sector Headquarter, SSB Purnea, on behalf of President of India invites **online** Percentage rate bids from approved and eligible contractors of CPWD and those of appropriate list of M.E.S. ,BSNL , Railway and Bihar state Building construction Department in two bid system for the following work(s):-

S. No.	NIT No.	Name of work and location	Estimated cost put to bid	Earnest Money	Period of Completion	Last date & time for submission of online bid, & deposition of original EMD.	Time & date of opening of Technical Bid
1	2	3	4	5	6	7	8
1	NIT No. – EE/SHQP/31/2025-26	Construction of Indo-Nepal Border pillars of 18 Bn Rajnagar, 45 Bn Birpur, 56 Batimaha & 52 Bn Araria under SHQ SSB Purnea.	Rs.46,35,288.00	Rs. 92,706.00	180 days	20/05/2026 at 1500 Hrs & 20/05/2026 at 1200 Hrs	21/05/2026 after 1600 Hrs

1. Contractors who fulfill the following requirements shall be eligible to apply. Joint ventures are not accepted.

(a) Should have satisfactorily completed the works as mentioned below during the last Seven years ending last day of the month previous to the one in which tenders are invited.

(i) Three similar works each costing not less than **Rs. 18,54,115/- (40% of ECPT)**, or two similar works each costing not less than **Rs. 27,81,173/-(60% of ECPT)** or one similar work costing not less than **Rs. 37,08,230 /- (80% of ECPT)**. Similar work means **Construction works (i.e Civil works of RCC)**. The value of executed works shall be brought to current costing level by enhancing the actual value of work at simple rate of 7% per annum; calculated from the date of completion to previous day of last day of submission of tenders.

(b) Should have had Average Annual Financial Turnover of **Rs. 13,90,586 /-(30% of the work value for last 03 years)** on construction works during the immediate last three years ending

31st March 2026. (Scanned copy of Certificate from CA with Unique Document Identification Number (UDIN) to be uploaded). The value of annual turnover figures shall be brought to the current value by enhancing the actual turnover figures at simple rate of 7% per annum.

(c) Should not have incurred any loss (profit after tax should be positive) in more than two years during the last five years ending **31st March 2026.**

(d) Should have a Banker's Certificate from a commercial Bank for **Rs. 18,54,115/- (40% of ECPT)** or Net Worth certificate from CA with Unique Document Identification Number (UDIN) of minimum **10 %** amount of ECPT (Scanned copy of original to be uploaded).

2. The intending bidder must read the terms and conditions of CPWD-6 carefully. He should only submit his bid if he considers himself eligible and he is in possession of all the documents required.

3. This information and instructions for bidders posted on website shall form part of bid document.

4. The bid document consisting of Plans, Specifications, Schedule of quantities of various types of items to be executed and the set of terms and conditions of the contract to be complied with and other necessary documents can be seen and downloaded from www.eprocure.gov.in free of cost.

5. But the bid can only be submitted after deposition of original EMD in the office of **Dy. Inspector General, Sector Headquarters, SSB, Purnea** within the period of bid submission and uploading the mandatory scanned documents such as TDR or Fixed Deposit Receipts from any of the Commercial Bank towards EMD in favour of as mentioned in NIT, deposition of original EMD and Banker's Certificate to office of **Dy. Inspector General, Sector Headquarters, SSB, Purnea** and certified copies of other documents as specified should be deposited before last date and time of bid submission.

6. The intending bidder must have valid class-III digital signature certificate with encryption key (combo type) to perform any operations/transactions on the website.

7. On opening date, the contractor can login and see the bid opening process. After opening of bids, he will receive the competitor bid sheets.

8. Contractor can upload documents in the form of **PDF format.**

9. **Certificate of Financial Turn Over:** At the time of submission of bid contractor may upload Affidavit/Certificate from CA mentioning Financial Turnover of last 7 years or for the period as specified in the bid document and further details if required may be asked from the contractor after opening of technical bids. **There is no need to upload entire voluminous balance sheet.**

10. Contractor must ensure to quote rate of each item. The column meant for quoting rate in figures appears in yellow colour and the moment rate is entered, it turns sky blue.

In addition to this, while selecting any of the cells a warning appears that if any cell is left blank the same shall be treated as "0"(ZERO). Therefore, if any cell is left blank and no rate is quoted by the bidder, rate of such item shall be treated as "0" (ZERO).

However, If a tenderer quotes nil rates against each item in item rate tender or does not quote any percentage above/below on the total amount of the tender or any section / sub head in percentage rate tender, the tender shall be treated as invalid and will not be considered as lowest tenderer.

11. The Technical Bid shall be opened first on given date and time as mentioned above. The time and date of opening of financial bid of contractors qualifying the technical bid shall be communicated to them at a later date.

12. Pre-Bid conference shall be held in the chamber of **Deputy Commandant (Engineer), Sector Headquarters, SSB at O/o the Dy. Inspector General, SHQ, SSB, Muzffarpur on 14/05/2026 at 1200 Hrs** to clear the doubt of intending bidders, if any.

13. **The department reserves the right to reject any prospective application without assigning any reason and to restrict the list of qualified contractors to any number deemed suitable by it, if too many bids are received satisfying the laid down criterion.**

14. The contractor submitting the bid should read the schedule of quantities, Special conditions, additional conditions, particular specifications and other terms and conditions given in the NIT and drawings. The bidder should also read the **General Conditions of Contract for CPWD Works 2023(Construction work) with all correction slips** issued up to the last date for submission of bid, which is available **at CPWD website**. However, provisions included in the bid document shall prevail over the provisions contained in the standard form. The set of drawings and NIT shall be available with the **Deputy Commandant (Engineer), Sector Headquarters, SSB, Purnea**. The contractor may visit the site of work and acquaint himself with the site conditions before tendering. The following conditions, which already form part of the tender conditions, are specially brought to his notice for compliance while filling the tender. They are requested to comply with the following instructions.

15. Tenders with any condition including that of conditional rebates shall be rejected. Such tenders shall not be entered in the tender opening register at the time of opening of tender.

16. The successful tenderer shall be required to submit a **Performance Guarantee of 5% (Five Percent)** of the tendered amount within **7 days** of issue of letter of intent. This period can be further extended by Engineer-in-Charge upto a maximum period of 7 days on the written request of the contractor subject to payment of late fee @0.1% per day of Performance Guarantee amount.

17. GST on all materials as well as GST on Work Contract etc., or any other taxes applicable in respect of this contract shall be payable by the Contractor. Percentage rate quoted by him shall be inclusive of all such taxes, levies etc. and Government will not entertain any claim for reimbursement whatsoever in respect of the same. The percentage rates of the contract shall be inclusive of all taxes and levies and nothing extra shall be paid. Further the percentage rate quoted

by the contractor shall be inclusive of labour welfare cess and the same shall be recovered from the contractors' bills and will be remitted by the department.

18. Applicants are advised to keep visiting the <https://ssb.gov.in> or eprocure.gov.in websites as applicable from time to time (till the deadline for bid submission) for any updates in respect of the tender documents, if any. Failure to do so shall not absolve the applicant of his liabilities to submit the application complete in all respects including updates thereof, if any. An incomplete application may be liable for rejection.

19. This work requires engaging more than 20 nos. of labours/workers and therefore all necessary licenses such as Labour license, EPFO and ESI, BOCW welfare registration etc., shall be taken by contractor within the time limits as prescribed under Clause-1 of Schedule- 'F'.

20. Contractor shall not divert any advance payments or part thereof for any other purpose other than needed for completion of the contracted work. All advance payments received as per terms of the contract (i.e. ~~mobilization, secured against materials brought at site, secured against plant & machinery~~ and or for work done during interim stages, etc.) are required to be re-invested in the contracted work to ensure advance availability of resources in terms of materials, labour, plant & machinery needed for required pace of progress for timely completion of work.

21. If any information furnished by the applicant is found incorrect at a later stage, he shall be liable to be debarred from tendering/taking up of works in SSB. The department reserves the right to verify the particulars furnished by the applicant independently.

22. The safety and security of the completed Border pillar is the responsibility of the contractor till they are handed over to SSB. After completion of the work, taking over process may take time and the responsibility of the Border pillar including all fixtures and fittings/constructed infrastructure is the complete responsibility of the contractor and nothing extra shall be payable on this account.

23. GST applicable as per Government norms up to date. Contractor should quote the rate including GST as per Govt. norms, nothing to be reimbursed against GST directly.

24. The Earnest money will not be considered as a part of Performance Guarantee. Performance Guarantee should be submitted separately by the successful bidder.

25. Supplementary agreement will be applicable on guaranteed items such as water proofing treatment etc.

26. Any dispute arising out of this tender including dispute related to encashment of any Bank Guarantee/ FDR etc., shall be subject to the jurisdiction of courts at **Patna** only.

27. Contractor may visit the site to assess the condition of site. A certificate in this regard may be obtained from the concerned unit In charge for proof of visiting the site accordingly.

List of Documents to be scanned and uploaded within the period of bid submission:

- (I) Enlistment Order of the Contractor.
- (II) Work Experience certificate of **Similar nature of work** as specified at Page No-5 of NIT.
- (III) Certificate of Financial Turnover from CA.
- (IV) Banker's Certificate or Net Worth Certificate as specified in Form-B.
- (V) **Receipt of deposition of original EMD issued by the office of Deputy Commandant (Engineer), O/O The DIG, SHQ SSB Purnea-854301.**
- (VI) Signed copy of CPWD Form-7
- (VII) Structure and Organization (Form-E)
- (VIII) Self-declaration (Form-F)
- (IX) PAN card of firm/agency.
- (X) Affidavit as per provisions of clause 1.2.3 of CPWD-6.
- (XI) **Receipt of site visit issued by any of the concerned Unit/BOP In charge.**
- (XII) Valid GST registration Certificate of Bihar, if already obtained by the bidder.

If the bidder has not obtained GST registration as applicable, then he shall scan and upload following undertaking along with bid documents.

"If work is awarded to me, I/we shall obtain GST registration certificate as applicable within one month from the date of receipt of award letter or before release of any payment by SSB, whichever is earlier, failing which I/we shall be responsible for any delay in payments which will be due towards me/us on account of the work executed and/or for any action taken by SSB or GST department in this regard".

- (XIII) **The bid will not be considered / rejected if,**
 - a) **The bidder does not deposit original EMD within stipulated bid submission time period.**
 - b) **The bidder does not upload scanned copies of all the required documents stipulated in the bid documents.**

(XIV) The department will not be responsible for delay in online submission of tender due to any reason whatsoever.

(XV) All the bidders are instructed to upload documents as per NIT. Uploading of irrelevant/un-necessary documents at the time of submission of bid may be avoided strictly.

All tenderers are requested to visit websites regularly to check changes, if any, in the Tender document. No separate communication will be made. Tenderer must ensure up-loading of Legible Documents.

12/5/26
Deputy Commandant (Er.)
SHQ, SSB, Purnea

CPWD-6 FOR E-TENDERING

1. Online Percentage rate bid is invited on behalf of President of India from approved and eligible contractors of CPWD and those of appropriate list of M.E.S., BSNL, Railway and Bihar State Building Construction Department for the work of **Construction of Indo-Nepal Border pillars of 18 Bn Rajnagar, 45 Bn Birpur, 56 Bathnaha & 52 Bn Araria under SHQ SSB Purnea.**

The enlistment of the contractors should be valid on the last date of submission of bid. In case the last date of submission of bid is extended, the enlistment of contractor should be valid on the original date of submission of bid.

1.1 The work is estimated to cost **Rs.46,35,288/- (Civil)** This estimate, however, is given merely as a rough guide.

1.2 Intending bidders is eligible to submit the bid provided he has definite proof from the appropriate authority, which shall be to the satisfaction of the competent authority, of having satisfactorily completed similar works of magnitude specified below: - Criteria of eligibility for submission of bid documents.

To become eligible for issue of bid, the bidders shall have to furnish an affidavit as under:

I/We undertake and confirm that eligible similar works(s) has/have not been got executed through another contractor on back to back basis. Further that, if such a violation comes to the notice of Department, then I/we shall be debarred for bidding in SSB in future forever. Also, if such a violation comes to the notice of Department before date of start of work, the Engineer-in-Charge shall be free to forfeit the entire amount of Earnest Money Deposit/Performance Guarantee. **(Scanned copy to be uploaded at the time of submission of bid).**

1.2.1 When bids are invited from contractors as per provisions of clause 1.2.1 above, it will be mandatory for contractors to upload the work experience certificate(s) and the affidavit as per the provisions of clause 1.2.2. Uploading of these two letters is mandatory otherwise system will not clear mandatory fields.

2. Agreement shall be drawn with the successful bidders on prescribed Form No. CPWD-7 which is available as a Govt. of India Publication and also available on website www.eprocure.gov.in Bidders shall quote his rates as per various terms and conditions of the said form which will form part of the agreement.

3. The time allowed for carrying out the work will be **180 days** from the date of start as defined in schedule 'F' or from the first date of handing over of the site, whichever is later, in accordance with the phasing, if any, indicated in the bid documents.

4. (i) The site for the work is available.

(ii) The architectural and structural drawing for the work is available.

5. The bid document consisting of plans, specifications, the schedule of quantities of various types of items to be executed and the set of terms and conditions of the contract to be complied with and other necessary documents except **General Conditions of Contract for CPWD Works 2023(Construction work) with all correction slips** issued up to the last date for submission of bid, can be seen on website <https://eprocure.gov.in> and on www.ssb.nic.in free of cost.

6. After submission of the bid the contractor can re-submit revised bid any number of times but before last time and date of submission of bid as notified.

7. While submitting the revised bid, contractor can revise the rate of one or more item(s) any number of times (he need not re-enter rate of all the items) but before last time and date of submission of bid as notified.

8. Earnest Money in the form of Bank Guarantee or Fixed Deposit Receipt from any of the Commercial Banks (drawn in favour of **Dy. Inspector General, Sector Headquarters, SSB, Purnea**) shall be scanned and uploaded on the e-Tendering website within the period of bid submission. The original EMD should be deposited in the office of **Dy. Inspector General, Sector Headquarters, SSB, Purnea** by due date & time as per NIT.

The earnest money given by all the tenderers except the lowest tenderer shall be refunded immediately after the expiry of stipulated bid validity period or immediately after acceptance of the successful bidder, whichever is earlier. However, in case of two/ three bid system, earnest money deposit of bidders unsuccessful during technical bid evaluation etc. should be returned within 30 days of declaration of result of technical bid evaluation.

Legible copy of Enlistment Order and certificate of work experience and other documents as specified in the notice inviting e-tender shall be scanned and uploaded on the e-Tendering website within the period of bid submission. Online bid documents submitted by intending bidders shall be opened only of those bidders, whose original EMD, original Bank Solvency Certificate and certified copy of all the scanned and uploaded documents as specified in e-tender notice deposited with **Deputy Commandant (Engineer), Sector Headquarters, SSB, Purnea** or any other documents scanned and uploaded are found in order.

The bid submitted shall be opened after **1600 Hrs on 21/05/2026**.

9. The bid submitted shall become invalid and e-Tender processing fee (if applicable) shall not be refunded if:

(i) The bidder is found ineligible.

(ii) The bidder does not upload scanned copies of all the documents stipulated in the bid document.

(iii) If any discrepancy is noticed between the documents as uploaded at the time of submission of bid and hard copies as submitted physically by the lowest bidder in the office of bid opening authority.

(iv) If a tenderer quotes nil rates against each item in item rate tender or does not quote any percentage above/below on the total amount of the tender or any section / sub head in percentage rate tender, the tender shall be treated as invalid and will not be considered as lowest tenderer.

10. The contractor whose bid is accepted will be required to furnish performance guarantee at specified percentage of the tendered amount as mentioned in Schedule 'E' and within the period specified in Schedule 'F'. This guarantee shall be in the form of Fixed Deposit Receipt

from any of the Commercial Banks in accordance with the prescribed form. In case the contractor fails to deposit the said performance guarantee within the period as indicated in Schedule 'F', including the extended period if any, the Earnest Money deposited by the contractor shall be forfeited automatically without any notice to the contractor. The earnest money deposited along with bid shall be returned after receiving the aforesaid performance guarantee. The contractor whose bid is accepted will also be required to furnish either copy of applicable licenses/ registrations or proof of applying for obtaining labour licenses, registration with EPFO, ESIC and BOCW Welfare Board including Provident Fund Code No. If applicable, and also ensure the compliance of aforesaid provisions by the subcontractors, if any engaged by the contractor for the said work within the period specified in Schedule 'F'.

11. The description of the work is as follows:- **Construction of Indo-Nepal Border pillars of 18 Bn Rajnagar, 45 Bn Birpur, 56 Bathnaha & 52 Bn Araria under SHQ SSB Purnea.**

Intending Bidders are advised to inspect and examine the site and its surroundings and satisfy themselves before submitting their bids as to the nature of the ground and sub-soil (so far as is practicable), the form and nature of the site, the means of access to the site, the accommodation they may require and in general shall themselves obtain all necessary information as to risks, contingencies and other circumstances which may influence or affect their bid. A bidder shall be deemed to have full knowledge of the site whether he inspects it or not and no extra charge consequent on any misunderstanding or otherwise shall be allowed. The bidder shall be responsible for arranging and maintaining at his own cost all materials, tools & plants, water, electricity access, facilities for workers and all other services required for executing the work unless otherwise specifically provided for in the contract documents. Submission of a bid by a bidder implies that he has read this notice and all other contract documents and has made himself aware of the scope and specifications of the work to be done and of conditions and rates at which stores, tools and plant, etc. will be issued to him by the Government and local conditions and other factors having a bearing on the execution of the work.

12. The competent authority on behalf of the President of India does not bind itself to accept the lowest or any other bid and reserves to itself the authority to reject any or all the bids received without the assignment of any reason. All bids in which any of the prescribed condition is not fulfilled or any condition including that of conditional rebate is put forth by the bidder shall be summarily rejected.

13. Canvassing whether directly or indirectly, in connection with bidders is strictly prohibited and the bids submitted by the contractors who resort to canvassing will be liable for rejection.

14. The competent authority on behalf of President of India reserves to himself the right of accepting the whole or any part of the bid and the bidder shall be bound to perform the same at the rate quoted.

15. The contractor shall not be permitted to bid for works in SSB responsible for award and execution of contracts, in which his near relative is posted as an Accountant or as an officer in any capacity between the grades of Superintending Engineer and Junior Engineer (both

inclusive). He shall also intimate the names of persons who are working with him in any capacity or are subsequently employed by him and who are near relatives to any Gazetted Officer in SSB or in the Ministry of Home Affairs. Any breach of this condition by the contractor would render him liable to be debarred for further tendering in SSB department.

16. No Engineer of Gazetted Rank or other Gazetted Officer employed in Engineering or Administrative duties in an Engineering Department of the Government of India is allowed to work as a contractor for a period of one year after his retirement from Government service, without the prior permission of the Government of India in writing. This contract is liable to be cancelled if either the contractor or any of his employees is found any time to be such a person who had not obtained the permission of the Government of India as aforesaid before submission of the bid or engagement in the contractor's service.

17. The bids for the work shall remain open for acceptance for a period of **75 (Seventy Five)** days from the date of opening of technical bids. Further,

(i) If any tenderer withdraws his tender or makes any modification in the terms & conditions of the tender which is not acceptable to the department within 7 days after last date of submission of bids, then the Government shall without prejudice to any other right or remedy, be at liberty to forfeit 50% of the earnest money absolutely irrespective of letter of acceptance for the work is issued or not.

(ii) If any tenderer withdraws his tender or makes any modification in the terms & conditions of the tender which is not acceptable to the department after expiry of 7 days after last date of submission of bids, then the Government shall without prejudice to any other right or remedy, be at liberty to forfeit 100% of the earnest money absolutely irrespective of letter of acceptance for the work is issued or not.

(iii) In case of forfeiture of earnest money as prescribed in para (i) and (ii) above, the bidders shall not be allowed to participate in the rebidding process of the same work.

18. This notice inviting Bid shall form a part of the contract document. The successful bidder/ contractor, on acceptance of his bid by the Accepting Authority shall within 15 days from the stipulated date of start of the work, sign the contract consisting of:-

(a) The Notice Inviting Bid, all the documents including additional conditions, specifications and drawings, if any, forming part of the bid as uploaded at the time of invitation of bid and the rates quoted online at the time of submission of bid and acceptance thereof together with any correspondence leading thereto.

(b) Standard C.P.W.D. Form-7 or other Standard C.P.W.D. Form as applicable.

19. For Composite Bids

19.1 The Engineer in charge of the major component will call bids for the composite work. The cost of bid document and Earnest Money will be fixed with respect to the combined estimated cost put to tender for the composite bid.

19.2 After acceptance of the bid by competent authority, the **Engineer-in-charge** of the work shall issue letter of award on behalf of the President of India. After the work is awarded, the contractor will have to enter into agreement with Engineer-in-charge of the work.

19.3 Entire work under the scope of composite bid including major and all minor components shall be executed under one agreement.

19.4 Running payment for the work shall be made by Engineer-in-charge to the contractor as per agreement/condition of contract.

19.5 The composite work shall be treated as complete when all the components of the work are complete. The completion certificate of the composite work shall be recorded by Engineer-in-Charge.

19.6 Final bill of whole work shall be finalized and paid by the Engineer-in-charge of the work.

19.7 The intending bidders are required to upload their bids well in advance of last date of submission of tender.

CPWD – 7

Percentage Rate Tender & Contract for Works

Tender for the work of:- **Construction of Indo-Nepal Border pillars of 18 Bn Rajnagar, 45 Bn Birpur, 56 Bathnaha & 52 Bn Araria under SHQ SSB Purnea.**

(i) To be uploaded by bidder upto **1500 Hrs on 20/05/2026** at www.eprocure.gov.in

(ii) To be opened in presence of tenderers who may be present at **1600 Hrs on 21/05/2026** in the office of Deputy Commandant (Engineer), O/o the Dy. Inspector General, SSB, Kala Bhawan road, DRDA Building, Purnea-854301.

TENDER

I/We have read and examined the notice inviting tender, schedule, A, B, C, D, E & F Specifications applicable, Drawings & Designs, General Rules and Directions, Conditions of Contract, clauses of contract, Special conditions, Schedule of Rate & other documents and Rules referred to in the conditions of contract and all other contents in the tender document for the work.

I/We hereby tender for the execution of the work specified for the President of India within the time specified in Schedule 'F' viz., schedule of quantities and in accordance in all respect with the specifications, designs, drawing and instructions in writing referred to in Rule-1 of General Rules and Directions and in Clause 11 of the Conditions of contract and with such materials as are provided for, by, and in respect of accordance with, such conditions so far as applicable.

I/We agree to keep the tender open for **75 (Seventy Five)** days from the date of opening of technical bid and not to make any modification in its terms and conditions.

I/We have deposited EMD in Original for the prescribed amount in the office of concerned Executive Engineer as per the bid document.

A copy of earnest money deposit receipt of prescribed amount deposited in the form of Bank Guarantee or Fixed Deposit Receipt issued by a Commercial Bank, is scanned and uploaded.

If I/We, fail to furnish the prescribed performance guarantee within prescribed period, I/We agree that the said President of India or his successors, in office shall without prejudice to any other right or remedy, be at liberty to forfeit the said earnest money absolutely. Further, if I/We fail to commence work as specified, I/ We agree that President of India or the successors in office shall without prejudice to any other right or remedy available in law, be at liberty to forfeit the said performance guarantee absolutely. The said Performance Guarantee shall be a guarantee to execute all the works referred to in the tender documents upon the terms and

conditions contained or referred to those in excess of that limit at the rates to be determined in accordance with the provision contained in Clause 12.2 and 12.3 of the tender form.

Further, I/We agree that in case of forfeiture of Earnest Money or Performance Guarantee as aforesaid, I/We shall be debarred for participation in the re-tendering process of the work.

I/We undertake and confirm that eligible similar work(s) has/have not been got executed through another contractor on back to back basis. Further that, if such a violation comes to the notice of Department, then I/We shall be debarred for tendering in SSB in future forever. Also, if such a violation comes to the notice of Department before date of start of work, the Engineer-in-Charge shall be free to forfeit the entire amount of Earnest Money Deposit/Performance Guarantee.

I/We hereby declare that I/We shall treat the tender documents drawings and other records connected with the work as secret/confidential documents and shall not communicate information/derived there from to any person other than a person to whom I/We am/are authorized to communicate the same or use the information in any manner prejudicial to the safety & integrity of the State.

Dated

Signature of Contractor

Witness:

Postal Address

Address:

Occupation:

ACCEPTANCE

The above tender (as modified by you as provided in the letters mentioned hereunder) is accepted by me for and on behalf of the President of India for a sum of Rs.

.....
(Rupees.....
.....).
.....).

The letters referred to below shall form part of this contract agreement: -

- (a)
- (b)
- (c)
- (d)
- (e)
- (f)
- (g)

For & on behalf of the President of India.

Signatures

Dated:

Designation

PROFORMA OF SCHEDULES

SCHEDULE 'A':

Schedule of quantities :- As per BOQ

SCHEDULE "B" (schedule of material to be issued to the contractor):- Not applicable

SCHEDULE "C" (Tools and Plants to be hired to the contractor) :- Not applicable

SCHEDULE 'D':

Extra schedule for specific requirements/document for the work, if any"- NIL

SCHEDULE 'E':

Reference to General Conditions of contract

Name of work : **Construction/ repair of Indo-Nepal Border pillars of 18 Bn Rajnagar, 45 Bn Birpur, 56 Bathnaha & 52 Bn Araria under SHQ SSB Purnea.**

Estimated cost of work : Rs. 46,35,288/-

(i) Earnest money : Rs. 92,706/- (to be returned after receiving performance guarantee)

(ii) Performance Guarantee : 5% of tendered value.

(iii) Security Deposit : 2.5% of tendered value.

SCHEDULE 'F'(General Rules and Directions)

Officer inviting tender : Deputy Comdt. (Engineer), Sector Headquarters, SSB, Purnea.

Maximum percentage for quantity of items of work to be executed beyond which rates are to be determined in accordance with Clauses 12.2 & 12.3.

See below

Definitions:

2(vi) Engineer-in-Charge : Dy. Comdt. (Engineer), SSB, Sector Hqrs, SSB, Purnea.

2(viii) Accepting Authority : Superintending Engineer, Frontier Hqrs, SSB, Patna.

2(x) Percentage on cost of materials and labour to cover : **15%**
all overheads and profits

2(x)(b) Standard Schedule of Rate : Delhi Schedule of Rates 2023 (Civil), plus 13% Cost Index on Civil DSR Items, market rate & plus 25% for remoteness area.

2(xi) Department : Sashastra Seema Bal, MHA (GOI).

9(ii) Standard CPWD contract Form GCC2023 (Construction Work), CPWD Form 7 as modified & corrected upto last date of submission of bid.

Clause 1:

i)	Time allowed for submission of performance Guarantee, Programme Chart (Time and Progress) and applicable labour licenses, registration with EPFO, ESIC and BOCW Welfare Board or proof of applying thereof from the date of issue of letter of acceptance	7 Days
ii)	Maximum allowable extension with late fee at 0.1% per day of performance Guarantee amount beyond the period as provided in(i) above.	7 Days

Clause 2:

Authority for fixing compensation under Clause 2	Superintending Engineer, Frontier Hqrs, SSB, Patna.
--	---

- Clause 3 : Applicable**
Clause 3 A : Not applicable
Clause 4 : Applicable
Clause 5 : Applicable

Number of days from the date of issue of letter of acceptance for reckoning date of start:

15 days

Time allowed for completion of work:

180 days.

5.1 a Schedule for handing over site:-

Part	Portion of site	Description	Time period for handing over reckoned from date of issue of letter of intent
A	Portion without hinderance	---	All site is available
B	Portion with encumbrance	---	---
C	Portion dependent on the work of other agencies	Construction work is subjected to availability of Survey of India and Nepal Team.	---

5.1 b:- All required architectural, structural design and details shall be provided at the time of handing over of site / during the course of the work. The contractor is required to submit mile stone for completion of work within 07 (Seven days) of date of start of work.

Authority to decide:

- (i) Extension of time :- Superintending Engineer, Frontier Hqrs, SSB, Patna
(ii) Rescheduling of mile stones :- Superintending Engineer, Frontier Hqrs, SSB, Patna

(Physical hindrance register to be maintained by the executing agency at site and to be reviewed by concerned technical representative of SSB)

Clause 6: Applicable

Mode of measurement: Computerized Measurement Book (CMB)

Clause 7: Applicable

Gross work to be done together with net payment /adjustment of advances for material collected, if any, since the last such payment for being eligible to interim payment	Rs. 15.0 lakh
---	----------------------

Clause 7A:

Whether clause 7A shall be applicable	Yes Applicable
---------------------------------------	-----------------------

Clause 7B:

Whether clause 7B shall be applicable (Payment to third party)	Not Applicable
--	-----------------------

Clause 8:

Whether clause 8 shall be applicable (Completion Certificate and Completion plans)	Yes Applicable
--	-----------------------

Clause 8A:

Authority to decide compensation on account if contractor fails to submit completion plans, as built drawings, Services drawing, Standard Measurement Book and Other documents specified in NIT. The recovery rate for non-submission of completion plans by the contractor	Engineer-in-Charge Applicable at the rate of 0.025% per week subject to maximum of 0.1% of tendered value.
--	--

Clause : 9 **Not Applicable/Part applicable**

Clause : 9 a **Not applicable**

Clause : 10a **Applicable**

List of testing equipment to be provided by the contractor at site lab: **List enclosed.**

Clause 10B

(i)	Whether clause 10B(i) shall be applicable (Secured Advance on Materials)	Not applicable
(ii)	Whether clause 10B(ii) shall be applicable (Mobilization advance)	Not applicable
(iii)	Whether clause 10B(iii) shall be applicable (Interest & Recovery)	Not applicable
(iv)	Whether clause 10B(iv) shall be applicable	Not applicable

Clause 10C Not Applicable

Clause 10CC Not Applicable

Clause 10 D: Applicable

Clause 11

Specifications to be followed for execution of work	a.) For Civil work :- CPWD Specifications-2019 (Vol-I & Vol-II) with up-to date correction slips b.)where CPWD specification is silent, relevant BIS codes/MNRE specification shall be followed.
---	---

Clause 12:

Clause 12 .1 : Applicable

Clause 12.2 & 12.3 Applicable

Deviation limit beyond which clauses 12.2 & 12.3 shall apply for work	30% (Thirty Percent)
---	----------------------

Clause 12.4: Not Applicable

Clause 13 : Applicable

Clause 14 : Applicable

Clause 15 : Applicable

Clause 16 :

Competent Authority for deciding reduced rates.	Superintending Engineer, SSB, Ftr Hqr, Patna.
---	---

Clause 17 : Applicable

Defects liability shall be 12 (Twelve) months from the date of issue of completion certificate by the Deputy Commandant (Engineer), SHQ, SSB, Purnea.

Clause 18, 18 a & 18 b: Applicable

Clause 19 & 19 a to l: Applicable

(Engineer in charge is authority to take action in case of default on part of the contractor in complying of above clause)

Clause 20 : Applicable

Clause 21: Applicable

Work not to be sublet. Action in case of insolvency	Engineer-in-Charge
---	--------------------

Clause 37 **Applicable**
Clause 38 **Not applicable**
Clause 39 **Not applicable**
Clause 40 **Not applicable**
Clause 41 **Applicable**

12/5/26
Deputy Commandant (Engineer)
SHQ, SSB, Purnea

Receipt of Deposition of Original E.M.D.

Name of work:- Construction of Indo-Nepal Border pillars of 18 Bn Rajnagar, 45 Bn Birpur, 56 Bathnaha & 52 Bn Araria under SHQ SSB Purnea.

NIT No.- EE/SHQP/31/2025-26

Estimated cost:- 46,35,288 /-

Amount of earnest money Deposit: - 92,706/-

Last date & time of submission of original EMD :- 20/05/2026 at 1200 Hrs.

Name of Contractor:-

Amount of EMD:-

Date of Submission of EMD:-

Signature of EMD receiving officer:-

Name & Designation of EMD receiving officer;-

Office stamp:-

Receipt of BOP Site Visit

Name of work:- Construction of Indo-Nepal Border pillars of 18 Bn Rajnagar, 45 Bn Birpur, 56 Bathnaha & 52 Bn Araria under SHQ SSB Purnea.

NIT No.- EE/SHQP/31/2025-26

Estimated cost:- 46,35,288/-

Last date & time of submission of online Bid :- 20/05/2026 at 1500 Hrs.

Name of Contractor:-

Date of Site visit :-

Signature of the officer/official present at **site** at the time of visit: -

Name & Designation of the officer/official present at the site: -

Office stamp:-

FORM "B"

BANKER'S CERTIFICATE FROM A COMMERCIAL BANK

This is to certify that to the best of our knowledge and information that M/s./ Sh..... having marginally noted address,as a customer of our bank are/is respectable and can be treated as good for any engagement upto a limit of Rs..... (Rupees.....).

This certificate is issued without any guarantee or responsibility on the bank or any of the officers.

**(Signature) For the Bank
Date of Issue :**

NOTE

1. Banker's Certificates should be on letter head of the Bank, addressed to tendering authority.
2. In case of Partnership firm, certificate should include names of all partners as recorded with the Bank.
3. **Banker's certificate should be issued after publication of NIT.**

OR

FORM "B-1"

FORM FOR CERTIFICATE OF NET WORTH FROM CHARTERED ACCOUNTANT

"It is to certify that as per the audited balance sheet and profit & loss account during the financial year, the Net Worth of M/s (Name & Registered Address of individual/firm/ company), as on (the relevant date) isRs.after considering all liabilities. It is further certified that the Net Worth of the company has not eroded by more than 30 % in the last three years ending on (the relevant date)."

Unique Document Identification Number (UDIN)

Signature of Chartered Accountant

Name of Chartered Accountant

Membership No. of ICAI

Date and Seal

FORM "E"

STRUCTURE & ORGANISATION

1. Name & address of the bidder
2. Telephone no./Telex no./Fax no.
3. Legal status of the bidder (Scan & upload copies of original document defining the legal status)
 - (a) An Individual
 - (b) A proprietary firm
 - (c) A firm in partnership
 - (d) A limited Company or Corporation
4. Particulars of registration with various Government Bodies (Scan & upload attested photocopy)

Organization/Place of registration	Registration No.

5. Names and titles of Directors & Officers with designation to be concerned with this work.
6. Designation of individuals authorized to act for the organization
7. Has the bidder, or any constituent partner in case of partnership firm, limited company / Joint Venture, ever been convicted by the court of Law? If so, give details.
8. In which field of Civil Engineering construction, the bidder has specialization and interest?
9. Any other information considered necessary but not included above.

Signature of Bidder(s)

FORM "F"

Undertaking on structural stability and soundness of already completed buildings and infrastructure Projects.

NITNo. : EE/SHQP/31/2025-26

Name of Work : Construction of Indo-Nepal Border pillars of 18 Bn Rajnagar, 45 Bn Birpur, 56 Bathnaha & 52 Bn Araria under SHQ SSB Purnea.

I/we undertake and confirm that any building/infrastructure constructed by our firm/partnership firm/company has not suffered any failure, making it unfit for intended use, either due to structural design and defects or due to use of sub-standard materials or execution of sub-standard work, poor workmanship or any other reason during the last 25 (twenty five) years.

I/we, further, undertake that if such information comes to the notice of SSB, then Engineer-In-Charge shall be free to terminate the bid/agreement and to forfeit the entire amount of earnest money deposit, performance guarantee and security deposits.

I/we, also undertake that in addition to above, the Engineer-in-Charge shall be free to debar us forever from tendering in SSB.

The decision of Engineer-in-Charge or any higher authority shall be final and binding.

Signature of Notary
with stamp

Signature of bidder or an authorized
person of the firm with stamp

Note: Affidavit to be furnished on a 'non-judicial' stamp paper of Rs. 200/- (scanned copy of the notarized affidavit to be uploaded at the time of submission of bid).

AFFIDAVIT

(As per clause 1.2.3 of CPWD-6)

NITNo. : EE/SHQP/31/2025-26
Name of Work : Construction of Indo-Nepal Border pillars of 18 Bn Rajnagar, 45 Bn Birpur, 56 Bathnaha & 52 Bn Araria under SHQ SSB Purnea.

I/We undertake and confirm that eligible similar works(s) has/have not been got executed through another contractor on back-to-back basis. Further that, if such a violation comes to the notice of department, then I/We shall be debarred for bidding in SSB in future forever. Also, if such a violation comes to the notice of department before the date of start of work, the Engineer-In-Charge shall be free to forfeit the entire amount of earnest money deposit/performance guarantee.

(Scanned copy of this affidavit to be uploaded at the time of submission of bid).

NOTE: “A work is said to have been executed on “back-to-back “basis when the entire work or substantial part of the work forming the basis for evaluation of the eligibility of the bidder is got executed by the bidder through another contractor either by direct nomination or by call of tender”.

.....
Signed by an Authorized Officer of the firm with stamp

UNDERTAKING REGARDING GST REGISTRATION

(On Firm letter Pad)

To

The Deputy Commandant (Engineer),
Sector Headquarters, SSB,
Purnea, Bihar-854301.

Subject :- Construction/ repair of Indo-Nepal Border pillars of 18 Bn Rajnagar, 45 Bn Birpur, 56 Bathnaha & 52 Bn Araria under SHQ SSB Purnea.

Having examined the details given in press notice and bid document for the above work, I/We hereby submit the following.

"If work is awarded to me, I/we shall obtain GST registration certificate as applicable within one month from the date of receipt of award letter or before release of any payment by SSB, whichever is earlier, failing which I/we shall be responsible for any delay in payments which will be due towards me/us on account of the work executed and/or for any action taken by SSB or GST department in this regard".

Seal of bidder,

Date of submission

Signature(s) of bidder(s)

FIELD TESTING EQUIPMENT AND INSTRUMENTS TO BE PROVIDED BY THE CONTRACTOR AT HIS OWN COST

A. Testing Equipment at Field Laboratories (Minimum numbers specified against each of them)

Balances

1. 1.0 Kg to 10 kg capacity, semi-self indicating type- Accuracy 10 gm
2. 500 gm capacities, semi-self indicating type- Accuracy 1 gm
3. Pan balance- 5kg capacity- Accuracy 10 gms Sieves as per IS 460-1962.

Sieves as per IS 460-1962.

1. IS sieves - 450mm internal dia, of sizes 100mm, 80mm, 63mm, 50mm, 40mm, 25mm, 20mm, 12.5mm, 10mm, 6.3mm and 4.75mm complete with lid and pan.
2. IS sieves - 200mm internal dia (brass frame), consisting of 2.36mm, 1.18mm, 600 microns, 425 microns, 300 microns, 212 microns, 150 microns, 90 microns, 75 microns with lid and pan.

Equipment for slump test-slump cone, steel plate, tamping rod, steel scale, scoop.

1. Dial gauges, 25mm travel- 0.01mm/division least count - 1 nos.
2. Graduated measuring cylinders 200 ml capacity – 2 Nos.
3. Enamel trays (for efflorescence test for bricks)
 - (i) 300 mm x 250 mm x 40 mm - 1 Nos.
 - (ii) Circular plates of 250mm dia - 2 Nos.
4. Concrete cube moulds 15 x 15 x 15cm - 30 Nos.

(A) FIELD TESTING INSTRUMENTS

1. Steel tapes-3m , 30 mtr
2. Vernier calipers
3. Micrometer screw 25mm gauge.
4. A good quality plumb bob.
5. Spirit level, minimum 30cms long with 3 bubbles for horizontal vertical.
6. Wire gauge (circular type) disc.
7. Foot rule
8. Long Nylon thread
9. Magnifying glass.
10. Screw driver 30cms long
11. Ball pin hammer, 100 gms
12. Plastic bags for taking samples.
13. Compressive strength Testing Machines - 1 Nos (Properly calibrated)

LIST OF MACHINERY, TOOLS & PLANTS TO BE DEPLOYED BY THE CONTRACTOR AT SITE

Sl. No.	Equipment's	Numbers (Tentative)
1.	Needle Vibrators	2 Nos
2.	Screener for coarse sand and fine sand	1 No
3.	Centrifugal mono block water pump suitable for minimum 30 m head.	1 Nos
4.	Reversal drum mixer machine with hopper	1 No
5.	Semi Automatic Cement Concrete Batch Mixing Plant 8-12 Cum/Hour capacity with printing facilities	1 No
6.	Power driven earth rammer.	As per Actual requirement
7.	Auto level & staff.	1 No
8.	Iron Boxes of size 25x35x40 cm	6 Nos
9.	Shuttering Plate	As per Actual requirement
10.	Steel Props	As per Actual requirement
11.	Column shuttering sets	Complete set of One floor
12.	Tractor trolley	As per Actual requirement
13.	Hydraulic excavator	As per Actual requirement
14.	Boat / floating barge platform	As per Actual requirement
15.	Cofferdam (sandbags/ cantilever sheet piles/water filled bladders)	As per Actual requirement
16.	Any other machinery required for completion of the work as per decision of Engineer-in-Charge.	As per Actual requirement

GUARANTEE BOND TO BE EXECUTED BY CONTRACTORS FOR REMOVAL OF DEFECTS AFTER COMPLETION IN RESPECT OF WATER PROOFING WORKS

The Agreement made this day of two thousand and between son of of (hereinafter called the Guarantor of the one part) and the PRESIDENT OF INDIA (hereinafter called Government of the other part).

WHEREAS this agreement is supplementary to a contract (hereinafter called the Contract) dated and made between the GUARANTOR of the one part and the Government of the other part, whereby the Contractor, inter alia, undertook to render the buildings and structures in the said contract recited completely water and leak-proof.

AND WHEREAS GUARANTOR agreed to give a guarantee to the effect that the said structures will remain water and leak-proof for five years from the date of giving of water proofing treatment.

NOW THE GUARANTOR hereby guarantees that water proofing treatment given by him will render the structures completely leak-proof and the minimum life of such water proofing treatment shall be five years to be reckoned from the date after the maintenance period prescribed in the contract.

Provided that the guarantor will not be responsible for leakage caused by earthquake or structural defects or misuse of roof or alteration and for such purpose:

- (a) Misuse of roof shall mean any operation which will damage proofing treatment, like chopping of firewood and things of the same nature which might cause damage to the roof;
- (b) Alteration shall mean construction of an additional storey or a part of the roof or construction adjoining to existing roof whereby proofing treatment is removed in parts;
- (c) The decision of the Engineer-in-Charge with regard to cause of leakage shall be final.

During this period of guarantee the guarantor shall make good all defects and in case of any defect being found, render the building water-proof to the satisfaction of the Engineer-in-Charge at his cost, and shall commence the work for such rectification within seven days from the date of issue of the notice from the Engineer-in-Charge calling upon him to rectify the defects, failing which the work shall be got done by the Department by some other contractor at the GUARANTOR'S cost and risk. The decision of the Engineer- in-Charge as to the cost,

payable by the Guarantor shall be final and binding.

That if GUARANTOR fails to execute the water proofing or commits breach thereunder then the GUARANTOR will indemnify the Principal and his successors against all loss, damage, cost, expense or otherwise which may be incurred by him by reason of any default on the part of the GUARANTOR in performance and observance of this supplementary agreement. As to the amount of loss and/or damage and/or cost incurred by the Government, the decision of the Engineer-in-Charge will be final and binding on the parties.

IN WITNESS WHEREOF these presents have been executed by the Obligorand by and for and on behalf of the PRESIDENT OF INDIA on the day, month and year first above written.

Signed, sealed and delivered by OBLIGOR in the presence of

- 1.
- 2.

Signed for and on behalf of THE PRESIDENT OF INDIA by in the presence of

- 1.

PART – B
(CIVIL WORK)

PREFERRED MAKE OF MATERIALS
(FOR CIVIL WORKS)

1. Specification/brands names of materials (Refer materials, whichever are applicable for the scope of work) and finishes approved by the Engineer-in-Charge are listed below. However, preferred & equivalent material and finishes of any other specialized firms may be used, in case it is established that the brands specified below are not available in the market but only after approval of the alternate brand by the Engineer-in-Charge. The necessary cost adjustments on account of above change shall be made for the material. (See also condition of contract).
2. The preferred makes list of materials approved by the SE as per CPWD Work Manual-2022, Para-4.10 (3) (ix) are incorporated as mentioned below: -

The following brands shall be used if not otherwise mentioned in the items.

Sl. No.	Materials	Approved make
1.	POP CEILING: PLASTER OF PARIS – (ISI MARKED)	SAKARNI, JK POP, WONDER
2.	POLY-SULPHIDE SEALANT – (ISI MARKED)	PIDILITE, TUFFSEAL, SIKA, FOSROC.
3.	DAMP PROOF MATERIAL – (ISI MARKED)	IMPERMO, DURASEAL, ACCO-PROOF.
4.	STRUCTURAL STEEL SECTIONS – (ISI MARKED)	TATA, SAIL, RINL, JINDAL STEEL
5.	ADMIXTURE – (ISI MARKED)	FOSROC, SIKA.
6.	WHITE CEMENT – (ISI MARKED)	J.K. WHITE, BIRLA WHITE.
7.	WATER PROOFING COMPOUND – (ISI MARKED)	TAPCRETE, CICO, ACCOPROOF, IMPERMO, FOSROC, Dr. Fixit.
8.	EPOXY MORTAR – (ISI MARKED)	FOSROC, SIKA.
9.	WATER-PROOF CEMENT PAINT – (ISI MARKED)	NEROLAC, INDIGO, BERGER.
10.	SYNTHETIC ENAMEL PAINT – (ISI MARKED)	BERGER, NEROLAC, ASIAN.
11.	ACRYLIC EMULSION PAINT – (ISI MARKED)	ASIAN, BERGER, NEROLAC, ICI, DULUX.
12.	REINFORCEMENT STEEL – (ISI MARKED)	SAIL, TATA, RINL, JINDAL STEEL & POWER, JSW STEEL.
13.	PPC/OPC CEMENT – (ISI MARKED)	ACC, ULTRATECH, VIKRAM, SHREE CEMENT, AMBUJA, JAYPEE CEMENT, CENTURY & JK CEMENT.

Note: -

1. The above makes are subjected to the compliance of **Make in India** norms.

All fitting should be ISI certified/CPWD approved wherever applicable.

Note: - Superintending Engineer, Frontier Hqr, SSB, Patna reserves the right to add or delete any materials and Brands in the list of approved materials/brands on the recommendations of Engineer-in-charge.

PART – C

Drawings

DETAILS OF REINFORCEMENT OF MAIN PILLAR

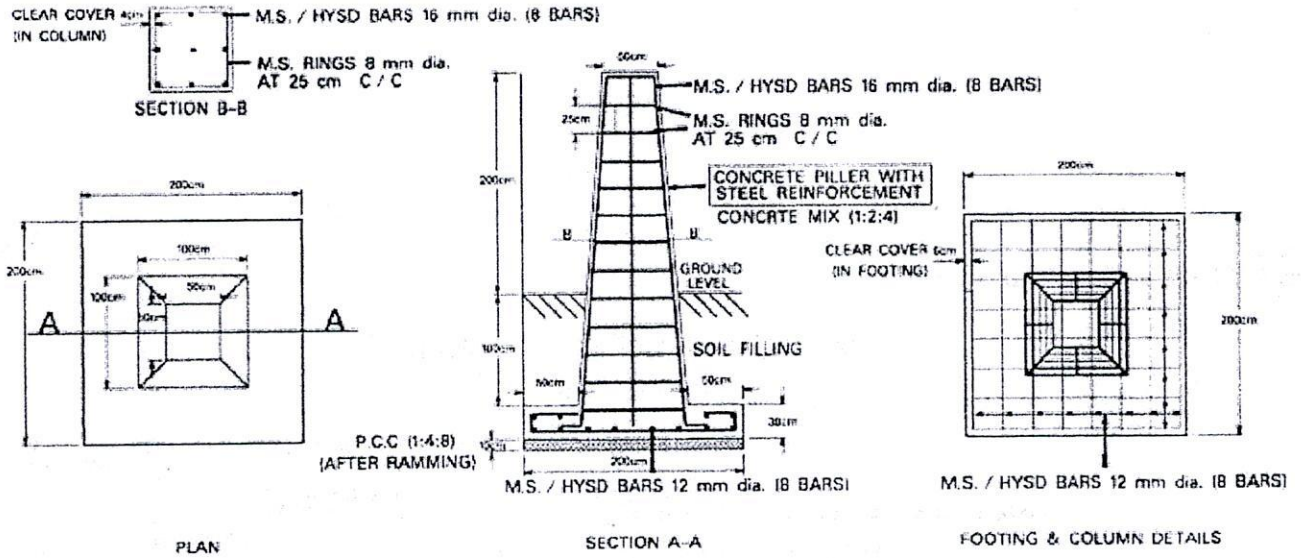

NOTE:- Provide 13 mm thick plaster on all sides of pillar.

[Handwritten signature]

[Handwritten signature]

DETAILS OF REINFORCEMENT OF SUBSIDIARY PILLAR

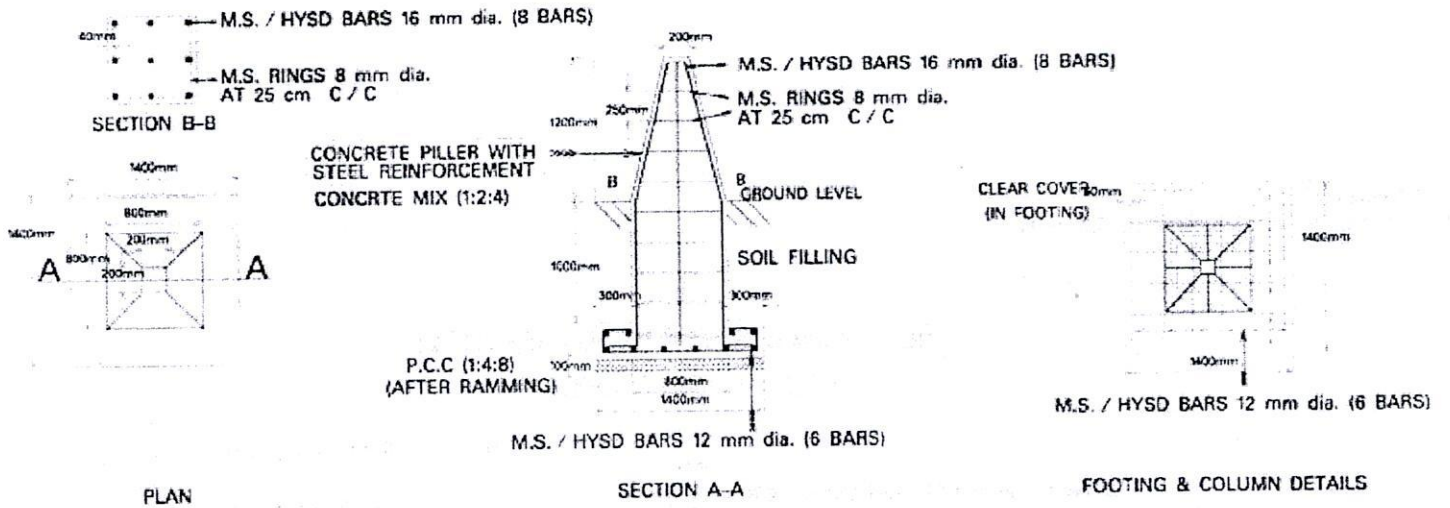

PLAN

SECTION A-A

FOOTING & COLUMN DETAILS

NOTE:- Provide 13 mm thick plaster on all sides of pillar.

Shalini

Sh

DETAILS OF REINFORCEMENT OF MINOR PILLAR

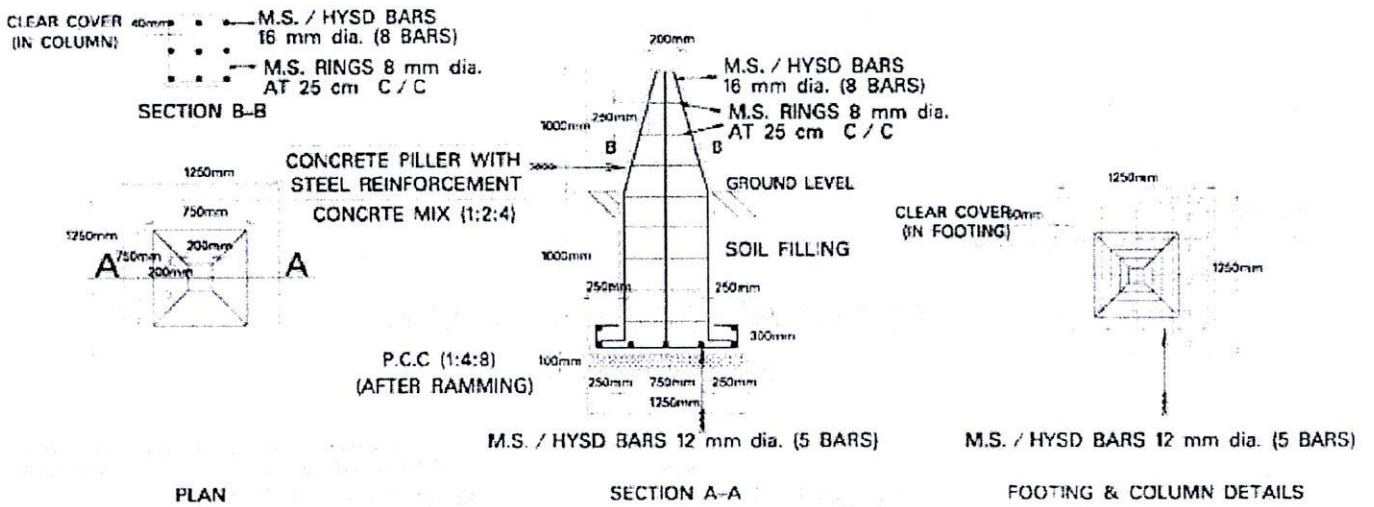

NOTE:- Provide 13 mm thick plaster on all sides of pillar.

Handwritten signature

Handwritten signature

DESIGN OF PILLAR IN THE BED OF SMALL RIVER (PROPOSED DESIGN)

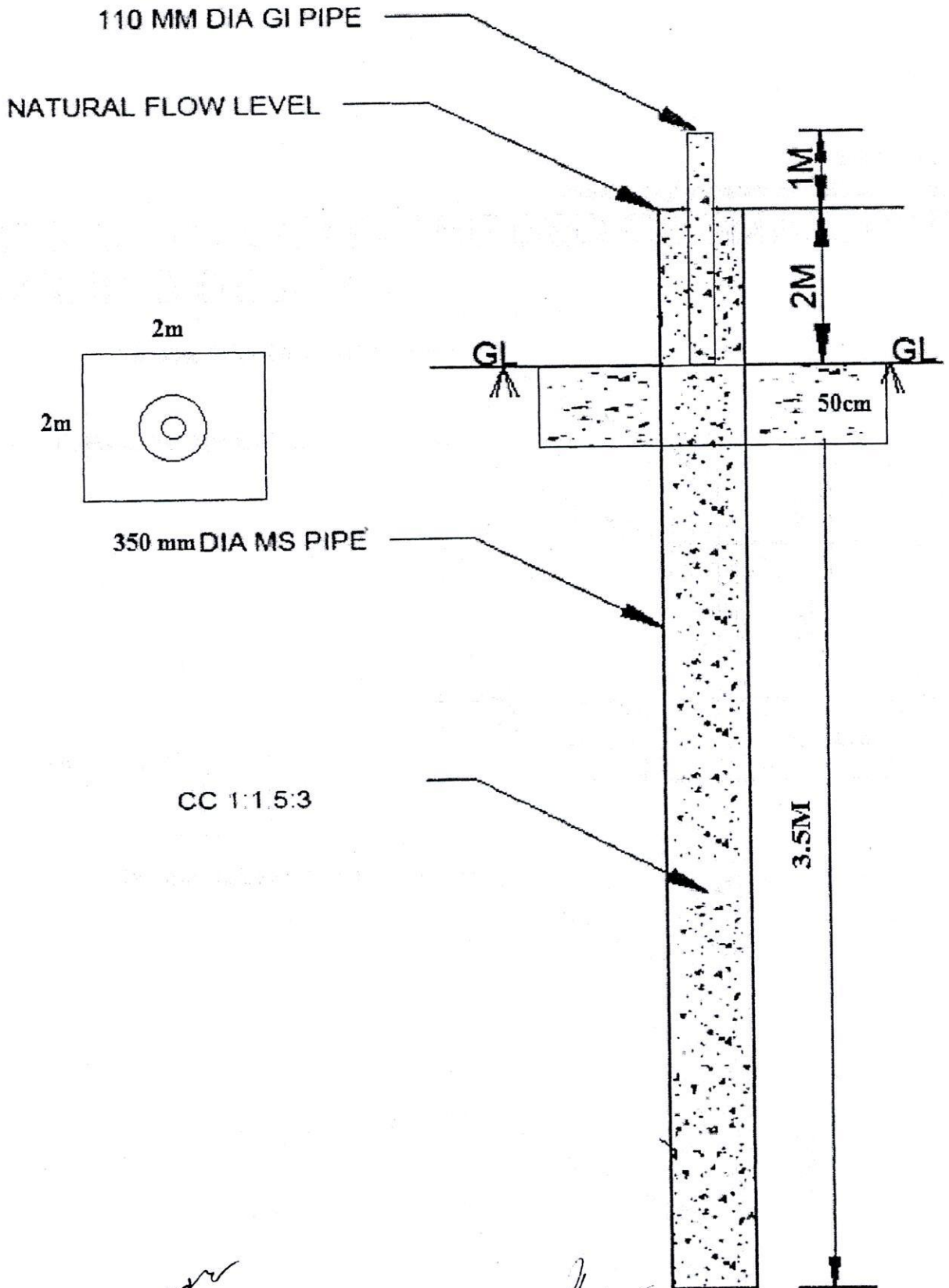

Handwritten signature

Handwritten signature

[Validate](#)[Print](#)[Help](#)

Percentage BOQ

Tender Inviting Authority: Deputy Commandant (Engineer), SHQ, SSB, Purnea (Bihar)

Name of Work: Construction of Indo- Nepal Border pillars of 18 Bn Rajnagar, 45 Bn Birpur, 56 Bn Bathnaha and 52 Bn Araria under SHQ SSB Purnea.

Contract No: EE/SHQP/31/2025-26

Name of the Bidder/ Bidding Firm /	
------------------------------------	--

PRICE SCHEDULE

(This BOQ template must not be modified/replaced by the bidder and the same should be uploaded after filling the relevant columns, else the bidder is liable to be rejected for this tender. Bidders are allowed to enter the Bidder Name and Values only)

NUMBE	TEXT #	NUMBER	TEXT #	NUMBER	NUMBER	NUMBER #	TEXT #
Sl. No.	Item Description	Quantity	Units	Estimated Rate including Cost index and remoteness Rs. P	TOTAL AMOUNT With all Taxes in Rs. P	TOTAL AMOUNT In Words	
1	Earth work in excavation by mechanical means (Hydraulic excavator)/ manual means over areas (exceeding 30cm in depth. 1.5 m in width as well as 10 sqm on plan) including disposal of excavated earth, lead upto 50m and lift upto 1.5m, disposed earth to be levelled and neatly dressed.	3	4	5	6	7	
							INR Thirty Thousand & Ninety and Paise Ninety Four Only

7	Centering and shuttering including strutting, propping etc. and removal of form for Foundations, footings, bases of columns, etc. for mass concrete	66.03	sqm	587.15	38769.51	INR Thirty Eight Thousand Seven Hundred & Sixty Nine and Paise Fifty One Only
8	Centering and shuttering including strutting, propping etc. and removal of form for Columns, Pillars, Piers, Abutments, Posts and Struts.	181.00	sqm	1439.31	260515.11	INR Two Lakh Sixty Thousand Five Hundred & Fifteen and Paise Eleven Only
9	Steel reinforcement for R.C.C. work including straightening, cutting, bending, placing in position and binding all complete. Cold twisted bars	6625.00	kg	161.48	1069805.00	INR Ten Lakh Sixty Nine Thousand Eight Hundred & Five Only
10	Steel work in built up tubular (round, square or rectangular hollow tubes etc.) trusses etc., including cutting, hoisting, fixing in position and applying a priming coat of approved steel primer, including welding and bolted with special shaped washers etc. complete.	2700.00	kg	291.06	785862.00	INR Seven Lakh Eighty Five Thousand Eight Hundred & Sixty Two Only
11	12 mm cement plaster of mix 1:6 (1 cement: 6 coarse sand)	101.65	sqm	514.53	52301.97	INR Fifty Two Thousand Three Hundred & One and Paise Ninety Seven Only
12	Finishing walls with water proofing cement paint of required shade 13.44.1 New work (Two or more coats applied @ 3.84 kg/10 sqm)	101.65	sqm	175.04	17792.82	INR Seventeen Thousand Seven Hundred & Ninety Two and Paise Eighty Two Only
13	Lettering with black Japan paint of approved brand and manufacture	7200.00	per letter per cm height	9.21	66312.00	INR Sixty Six Thousand Three Hundred & Twelve Only

14	Boring/drilling bore well of required dia for casing/ strainer pipe, by suitable method prescribed in IS: 2800 (part I), including collecting samples from different strata, preparing and submitting strata chart/ bore log, including hire & running charges of all equipments, tools, plants & machineries required for the job, all complete as per direction of Engineer -in-charge, upto 90 Metre depth below ground level. All types of soil: 400 mm dia.	40.00	mtr	1483.48	593339.20	INR Fifty Nine Thousand Three Hundred & Thirty Nine and Paise Twenty Only
15	Supply and fixing of 110 mm Dia G.I. Pipe	30.00	mtr	2175.50	65265.00	INR Sixty Five Thousand Two Hundred & Sixty Five Only
Total in Figures					4635287.66	INR Forty Six Lakh Thirty Five Thousand Two Hundred & Eighty Seven and Paise Sixty Six Only
Quoted Rate in Figures			Select		0.00	INR Zero Only
Quoted Rate in Words		INR Zero Only				

 12/11/2026
 DC/kr