



SEMI-CONDUCTOR LABORATORY

Ministry of Electronics and Information Technology
Government of India

Sector 72, S.A.S. Nagar – 160 071, Punjab, India
Phone: 0091 172 2296100/200/300/400 (Ext. 6169)

Fax: 0091 172 2237410

E-mail: naresh@scl.gov.in

INVITATION TO TENDER NO.: 45185

E-tender /Online bid is invited for “**Supply of Sealing Window for Imager-2 and Imager-3**” in accordance with the purchaser’s tender specifications. The invitation to tender, tendering conditions, general conditions of contract, special conditions of contract and additional conditions of contract, if any, which will govern the contract pursuant to tender are attached.

Bidders interested to submit bid are requested to go through the contents of this document and ensure that the bid is submitted online on or before the due date and time indicated in NIT and as per technical specifications and terms and condition indicated herein.

Please note all bid related documents scanned copy is to be submitted on the online portal, only EMD has to reach physical on mentioned address. (If applicable)

PSO



SEMI-CONDUCTOR LABORATORY
Ministry of Electronics and Information Technology
Government of India
Sector 72, S.A.S. Nagar – 160 071, Punjab, India
Phone: 0091 172 2296100/200/300/400 (Ext. 6169)
Fax: 0091 172 2237410
E-mail: naresh@scl.gov.in

Public Tender Enquiry

Tender Document

For

**Supply of Sealing Window for Imager-2 and Imager-3
TENDER NO.: 45185**

TENDER INVITING AUTHORITY

SEMI-CONDUCTOR LABORATORY

**MINISTRY OF ELECTRONICS AND INFORMATION
TECHNOLOGY**

GOVERNMENT OF INDIA

SECTOR 72, SAS NAGAR MOHALI

PUNJAB – 160 071

Direct – 0091 172-2296169

Email: naresh@scl.gov.in

TENDER NO.: 45185

Online bid invited for and on behalf of SCL, S.A.S Nagar, Punjab

Interested parties may view and download the tender document containing the detailed terms & conditions from the website
<https://eprocure.gov.in/eprocure/app>

(The bids have to be submitted online in electronic form on www.eprocure.gov.in only. No physical bids will be accepted)

Terms and Conditions:

1. SCL reserves the right of accepting or rejecting any quotations without assigning any reason thereof.
2. Samples, if called for, shall be submitted free of charge and with no obligation to SCL basis.
3. This is only an enquiry and not a purchase order.
4. The Purchaser reserves the right at the time of Contract award to increase or decrease the quantity of goods and services originally specified in the Schedule of Requirements without any change in unit price or other terms and conditions.
5. The Purchaser reserves the right to accept or reject any bid, and to amend the bidding process and reject all bids at any time prior to award of Contract, without thereby incurring any liability to the affected Bidder or Bidders.



SEMI-CONDUCTOR LABORATORY
Ministry of Electronics and Information Technology
Government of India
Sector 72, S.A.S. Nagar – 160 071, Punjab, India
Phone: 0091 172 2296100/200/300/400 (Ext. 6169)
Fax: 0091 172 2237410
E-mail: naresh@scl.gov.in

Tender Document

TENDER NO.: 45185

April 20, 2026

Subject: Quotation for “ Supply of Sealing Window for Imager-2 and Imager 3”-reg.

We intend to procure as per details given below:

Sr. no	SCL Material Code	Item Description and Specification	Qty.in Nos
1	230216276	Sealing Window for Imager-2 (Fabrication and supply) as per Specifications attached as Annexure-I	60
2	230216277	Sealing Window for Imager-3 (Fabrication and supply) as per Specifications attached as Annexure-I	60

Kindly submit your quotation online as per tender schedule.

Note:

- Tender details may be viewed and downloaded from the website. <https://eprocure.gov.in/eprocure/app>
- The bids have to be submitted online in electronic form on www.eprocure.gov.in only. No physical bids will be accepted.
- For any queries please mail us at naresh@scl.gov.in , vmehta@scl.gov.in Contact No. 0172-296169/2296175

Filled up response fully stamped and signed by authorized bidder to be scanned and uploaded

TENDER ACCEPTANCE LETTER

(To be given on Company Letter Head)

Date: _____

To,

Sub: Acceptance of Terms Conditions of Tender.

Tender Reference No: _____

Name of Tender / Work:- _____

Dear Sir,

1. I / We have downloaded / obtained the tender document(s) for the above mentioned 'Tender/Work' from the web site(s) namely: _____ as per your advertisement, given in the above mentioned website(s).

2. I / We hereby certify that I / we have read the entire terms and conditions of the tender documents (including all documents like annexure(s), schedule(s), etc .), which form part of the contract agreement and I / we shall abide hereby by the terms / conditions / clauses contained therein.

3. The corrigendum(s) issued from time to time by your department/ organization too has also been taken into consideration, while submitting this acceptance letter.

4. I / We hereby unconditionally accept the tender conditions of above mentioned tender document(s) / corrigendum(s) in its totality / entirety.

5. I / We do hereby declare that our Firm has not been blacklisted/ debarred/ terminated/ banned by any Govt. Department/Public Sector Undertaking.

6. I / We certify that all information furnished by our Firm is true correct and in the event that the information is found to be incorrect/untrue or found violated, then your department/ organization shall without giving any notice or reason therefore or summarily reject the bid or terminate the contract, without prejudice to any other rights or remedy including the forfeiture of the full said earnest money deposit absolutely.

Yours Faithfully,

**(Signature of the Bidder, with
Official Seal)**

INSTRUCTION FOR ONLINE BID SUBMISSION

The bidders are required to submit softcopies of their bids electronically on the Central Public Procurement (CPP) Portal i.e. <https://eprocure.gov.in/eprocure/app>, using valid Digital Signature Certificates. The instructions given below are meant to assist the bidders in registering on the CPP Portal, prepare their bids in accordance with the requirements and submitting their bids online on the CPP Portal.

REGISTRATION

- (i) Bidders are required to enroll on the e-Procurement module of the Central Public Procurement Portal ([URL:https://eprocure.gov.in/eprocure/app](https://eprocure.gov.in/eprocure/app)) by clicking on the link "Online Bidder Enrolment" option available on the home page.
- (ii) **Enrolment on the CPP Portal is free of charge.**
- (iii) During enrolment/registration, the bidders should provide the correct/true information including valid email-id & mobile no. All the correspondence shall be made directly with the contractors/bidders through email-id provided.
- (iv) As part of the enrolment process, the bidders will be required to choose a unique username and assign a password for their accounts.
- (v) Any bidder from a country which shares a land borders with India will be eligible to bid in any procurement whether of goods, services (including consultancy services and non-consultancy services) or works (including turnkey projects) only if the bidder is registered with the competent authority as mentioned in the GFR 2017 Rule 144(xi).
- (vi) For e-tendering possession of valid Digital Signature Certificate (Class III Certificates with signing key usage) is mandatory which can be obtained from SIFY /nCode/eMudra or any Certifying Authority recognized by CCA India on e-Token/Smartcard.
- (vii) Upon enrolment on CPP Portal for e-tendering, the bidders shall register their valid Digital Signature Certificate with their profile.
- (viii) Only one valid DSC should be registered by a bidder. Bidders are responsible to ensure that they do not lend their DSCs to others which may lead to misuse and should ensure safety of the same.
- (ix) Bidders can login to the site through the secured login by entering their user ID/password and the password of the DSC/ e-Token.

SEARCHING FOR TENDER DOCUMENTS

- 1) There are various search options built in the CPP Portal to facilitate bidders to search active tenders by several parameters. These parameters could include Tender ID, organization name, location, date, value, etc. There is also an option of advanced search for tenders, wherein the bidders may combine a number of search parameters such as organization name, form of contract, location, date, other keywords, etc., to search for a tender published on the CPP Portal.
- 2) Once the bidders have selected the tenders they are interested in, they may download the required documents / tender schedules. These tenders can be moved to the respective 'My Tenders' folder. This would enable the CPP

Portal to intimate the bidders through SMS / e-mail in case there is any corrigendum issued to the tender document.

- 3) The bidder should make a note of the unique Tender ID assigned to each tender, in case they want to obtain any clarification / help from the Helpdesk.

PREPARATION OF BIDS:

- (i) For preparation of bid, Bidders shall search the tender from published tender list available on site and download the complete tender document and should take into account corrigendum if any published before submitting their bids.
After selecting the tender document same shall be moved to the 'My favorite' folder of bidders account from where bidder can view all the details of the tender document.
- (ii) Bidder shall go through the tender document carefully to understand the documents required to be submitted as part of the bid. Bidders shall note the number of covers in which the bid documents have to be submitted, the number of documents – including the names and content of each of the document that need to be submitted. Any deviations from these may lead to rejection of the bid.
- (iii) Any pre-bid clarifications if required, then same may be obtained on line through the tender site, or through the contact details given in the tender document.
- (iv) Bidders should get ready in advance the bid documents in the required format (PDF/xls/rar/dwf/jpg formats) to be submitted as indicated in the tender document/schedule.
- (v) Bidders can update well in advance, the documents such as experience certificates, annual report, PAN, EPF & other details etc., under "My Space/ Other Important Document" option, which can be submitted as per tender requirements. This will facilitate the bid submission process faster by reducing upload time of bids.

SUBMISSION OF BIDS:

- (i) Bidder should log into the site well in advance for bid submission so that he/ she upload the bid in time i.e. on or before the bid submission time. Bidder will be responsible for any delay.
- (ii) Bidder should prepare the EMD as per the instructions specified in the NIT/tender document. The details of the DD/BC/BG/ others physically sent, should tally with the details available in the scanned copy and the data entered during bid submission time. Otherwise the uploaded bid will be rejected.
- (iii) While submitting the bids online, the bidder shall read the terms & conditions (of CPP portal) and accepts the same in order to proceed further to submit their bid.
- (iv) Bidders shall select the payment option as offline to pay the EMD and enter details of the DD/BC/BG/others.
- (v) Bidder shall digitally sign and upload the required bid documents one by one as indicated in the tender document.
- (vi) Bidders shall note that the very act of using DSC for downloading the tender document and uploading their offers is deemed to be a confirmation that

they have read all sections and pages of the tender document without any exception and have understood the complete tender document and are clear about the requirements of the tender document.

- (vii) **If price quotes are required in XLS format, utmost care shall be taken for uploading Schedule of quantities & Prices and any change/modification of the price schedule shall render it unfit for bidding.**

Bidders shall download the Schedule of Quantities & Prices i.e. Schedule-A, in XLS format and save it without changing the name of the file. Bidder shall quote their rate in figures in the appropriate cells, thereafter save and upload the file in financial bid cover (Price bid) only.

If the template of Schedule of Quantities & Prices file is found to be modified/corrupted in the eventuality by the bidder, the bid will be rejected and EMD if any shall be forfeited.

- (viii) Bidders shall submit their bids through online e-tendering system to the Tender Inviting Authority (TIA) well before the bid submission end date & time (as per Server System Clock). **The TIA will not be held responsible for any sort of delay or the difficulties faced during the submission of bids online by the bidders at the eleventh hour.**
- (ix) After the bid submission (i.e. after Clicking “Freeze Bid Submission” in the portal), the bidders shall **take print out of system generated acknowledgement** number and keep it as a record of evidence for online submission of bid, which will also act as an entry pass to participate in the bid opening.
- (x) Bidders should follow the server time being displayed on bidder’s dash board at the top of the tender site, which shall be considered valid for all actions of requesting, bid submission, bid opening etc., in the e-tender system.
- (xi) All the documents being submitted by the bidders would be encrypted using PKI (Public Key Infrastructure) encryption techniques to ensure the secrecy of the data. The data entered cannot be viewed by unauthorized persons until the time of bid opening. The confidentiality of the bids is maintained using the secured Socket Layer 128 bit encryption technology.

ASSISTANCE TO BIDDERS:

- (i) Any queries relating to the tender document and the terms and conditions contained therein should be addressed to the Tender Inviting Authority as per e-mail ID given in the tender.
- (ii) Any queries relating to the process of online bid submission or queries relating to CPP Portal in general may be directed to the 24X7 CPP Portal Helpdesk. The 24 x 7 Help Desk Number 0120- 4200462, 0120-4001002 and 0120-4001005. The helpdesk email id [is support-eproc@nic.in](mailto:is_support-eproc@nic.in)

INSTRUCTION FOR e-PROCUREMENT

1. PREPARATION AND SUBMISSION OF BIDS:

- a. The detailed tender documents may be downloaded from <https://eprocure.gov.in/eprocure/app> till the last date of submission of tender. The Tender may be submitted online through CPP Portal <https://eprocure.gov.in/eprocure/app>
- b. The bidder should submit the bid online in **two part** viz. Technical Bid and Financial Bid. Technical Bid and Financial Bid should be uploaded online in separately.

2. SUBMISSION OF THE BID : All interested eligible bidders are requested to submit their bids online on CPP Portal: <https://eprocure.gov.in/eprocure/app> as per the criteria given in this document:

- a. **Technical Bid and Financial Bid should be uploaded online separately.**
- b. **Both Technical and Financial Bid cover should be placed online on the CPPP separately.**
- c. Portal (<https://eprocure.gov.in/eprocure/app>).

3. TECHNICAL BID: Signed and Scanned copies of the Technical bid documents as under must be submitted online on CPP Portal: <https://eprocure.gov.in/eprocure/app>.

a) List of Documents to be scanned and uploaded (Under Cover-1) within the period of bid submission: -

- i. Scanned copy of Bank details. (Bank details of principal supplier in case of Import shipments)
- ii. Scanned copy of certificate of GST. (GSTIN of Indian Agent in case of Import Shipments) (Not applicable in case of foreign vendor)
- iii. Scan copy of tender acceptance letter.
- iv. Scanned copy of specifications or brochures (if any).
- v. Scanned copy of other document mentioned in tender document (if any)

b) For Import Shipments – Shipping Terms Ex-Works/FOB international airport basis.

4. Financial Bid

- a. In preparing the financial bids, bidders are expected to take into account the requirements and conditions laid down in this Tender document. The financial bid should be uploaded online as per the specified **“.Xls”** format i.e. Price Bid Excel sheet attached as **‘.Xls’** with the tender and based on the scope of work/Specifications, service conditions and other terms of the Tender document. It should include all costs associated with the Terms of Reference/Scope of Work/Specifications of the assignment.

5. Last Date for Submission of Tender:

- a. Online bids complete in all respects, must be submitted **on or before** the last date and time specified in the schedule of events.
- b. TIA may, at its own discretion, alter/extend the last date for

submission of tender.

6. Bid Validity

- a. All the Bids must be valid for a period of 120 day's from the last date of submission of the tender for execution of Contract. However, the quoted rates should be valid for the initial/ extended period of the Contract from the effective date of the Contract. No request will be considered for price revision during the original Contract period.
- b. A bid valid for a shorter period shall be declared as non-responsive.
- c. In exceptional circumstances, prior to expiry of the original time limit, SCL, Mohali may request the bidders to extend the period of validity for a specified additional period beyond the original validity of 120 days. The request and the bidders' responses shall be made in writing. The bidders, not agreeing for such extensions will be allowed to withdraw their bids without forfeiture of their Bid Security.

7. Modification / Substitution/ Withdrawal of bids:

- a. No Bid shall be modified, substituted or withdrawn by the Bidder after the Bid's due Date.
- b. Any alteration/ modification in the Bid or additional information supplied subsequent to the Bid's due Date, unless the same has been expressly sought for by the Authority, shall be disregarded.

8. Rejection of the Bid: The bid submitted shall become invalid and tender fee shall not be refunded if:-

- a. The bidder is found ineligible.
- b. The bidder does not upload all the documents as stipulated in the bid document.

Instructions to Tenderers (Global Tender)

The bidders are required to submit soft copies of their bids electronically on the Central Public Procurement (CPP) Portal i.e. <https://eprocure.gov.in/eprocure/app>, using valid Digital Signature Certificates (DSC). The instructions given below are meant to assist the bidders in registering on the CPP Portal, prepare their bids in accordance with the requirements and submitting their bids online on the CPP Portal.

1. Earnest Money Deposit (EMD):

- a. Bidders are required to submit offers along with prescribed Earnest Money Deposit (EMD) amount of Rs. 3,00,000.00 (Rupees Three lakh only) as per details in the tender. EMD instrument in original should be sent in a sealed cover with a covering letter quoting tender number and same must reach us prior to due date of tender. The scanned copy of EMD instrument should be attached online with the tender.
- b. Central PSUs/PSEs/Autonomous Bodies, Micro and Small Enterprises (MSEs) having valid registration with MSME or NSIC or Udyog Aadhaar, Khadi and Village Industries Commission (KVIC), National Small Industries Corporation, produced and provided by MSE and startups recognized by Department of Industrial Policy & Promotion (DIPP) etc., shall be exempted from the

- payment of EMD. Bidders seeking exemption from payment of EMD shall submit necessary proof of relevant documents etc.
- c. Foreign bidders can submit EMD in INR or in foreign currency of equivalent value.
 - d. **Indian agent/Indian counterpart submitting bid on behalf of foreign principal shall not be exempted for submitting EMD.**
 - e. **MSME submitting bid on behalf of foreign vendor shall not be exempted for submitting EMD.**
 - f. The bid submitted by vendor without EMD will not be considered.
 - g. EMD shall be submitted in a single installment through Demand Draft/Bankers Cheque/Fixed Deposit Receipts or Bank Guarantee in favour of Semi-Conductor Laboratory from any of the Scheduled Banks executed on non-judicial stamp paper of appropriate value. In case of fixed deposit receipt /bank guarantee, it shall be valid for a period of 45 days beyond the final tender validity date. EMD shall be interest free.
 - h. Vendors/firms name and tender no. shall be indicated on the reverse side of the EMD instrument.
 - i. EMD instrument should not be dated prior to the date of tender.
 - j. SCL will not be responsible for non-receipt of EMD instrument due to postal delay / loss in transit.
 - k. Any tender not accompanied with EMD shall be treated as invalid tender and rejected.
 - l. EMD of a bidder shall be forfeited if the tenderer/Contractor withdraws or amends his tender or deviates from the tender in any respect within the period of validity of the tender. Failure to furnish security deposit/performance bond by a successful vendor within the specified period shall also result in forfeiture of EMD.
 - m. EMD shall be refunded to all the unsuccessful bidders within thirty (30) days after placement of the Purchase Order. EMD shall be refunded to the successful tenderer/Contractor after payment of the Security Deposit or may be adjusted against the Security Deposit. EMD shall be refunded to all the participants in cases where the tender is cancelled or withdrawn by the purchaser, within thirty days from the date of such cancellation or withdrawal.
2. **This being a two part (Cover) tender i.e. technical and financial part separate, the Technical part should not contain Pricing information of the Tendered stores. The tenders containing Price details of the Tendered stores in Technical Part (Cover-1) will be summarily rejected. Prices should be indicated in the Financial Part (Cover -2) only.**
 3. Request for the extension of the due date will not be considered.
 4. SCL reserves the right to accept or reject any / or all the tenders in part or full without assigning any reasons thereof. The bidder is at liberty to seek information related to bidding conditions, bidding process and/or rejection of its bid.
 5. In this tender either the Indian Agent on behalf of the Principal/OEM or the Principal/OEM itself can bid, but both cannot bid simultaneously for the same item. Indian agents while quoting on behalf of their principals shall provide necessary latest authorization letter obtained from their Principals / Manufacturers in their bid.
 6. If an agent submits bid on behalf of the Principal/OEM, the same agent shall not

submit a bid on behalf of another Principal/OEM in the tender for the same item. If submitted, all offers submitted by the said agent shall be excluded from the procurement process.

7. SCL reserves the right to exclude the bidder from procurement process who have not agreed to furnish Security Deposit and Performance Bank Guarantee as sought vide this tender.
8. In case the bidder gives shorter validity than the period specified in the tender enquiry. SCL reserves the right to exclude the bidder from procurement process.
9. Late tenders, delayed tenders, fax quotations and e-mail quotations are not considered. Only tender submitted through CPP Portal shall be considered.
10. SCL reserves the right to verify all claims made by the bidder.
11. SCL reserves the right to change any milestone date of the tendering activity / tender schedule.
12. Tender which is not submitted as per the of instructions mentioned herein is liable to be rejected.
13. The purchaser shall be under no obligation to accept the lowest or any tender and reserves the right of acceptance of the whole or any part of the tender or portions of the quantity offered and the tenderer shall supply the same at the rates quoted.
14. It is expressly agreed that the acceptance of the Stores Contracted for is subject to final approval in writing by the Purchaser.
15. It is to be noted that the drawings, specifications, end-use, etc., given by the purchaser, are confidential and shall not be disclosed to any third party.
16. Prices are required to be quoted according to the units indicated in the tender. When quotations are given in terms of units other than those specified in the tender form, relationship between the two sets of units must be furnished.
17. The Prices are to be mentioned both in figures as well as in words. The taxes, duties etc. are to be calculated and indicated in the column provided in online forms explicitly.
18. Bidders are expected to comply with commercial and other terms and conditions given in vendor specified terms of this tender. In case of any deviation, the reasons thereof should be clearly specified in the vendor specified terms column.
19. All available technical literature, catalogues and other data in support of the specifications and details of the items should be furnished along with the offer.
20. Samples, if called for, should be submitted free of all charges by the tenderer and the Purchaser shall not be responsible for any loss or damage thereof due to any reason whatsoever. In the event of non- acceptance of tender, the tenderer will have to remove the samples at his own expense.
21. Approximate net and gross weight of the items offered wherever required shall be indicated in your offer. If dimensional details are available the same should also be indicated in your offer.
22. Specifications: Stores offered should strictly confirm to our specifications. Deviations, if any, should be clearly indicated by the tenderer in his bid. The tenderer should also indicate the Make/Type number of the stores offered and provide catalogues, technical literature and samples, wherever necessary, along with the quotations. Test Certificates, wherever necessary, should be forwarded along with supplies. Wherever options have been called for in our specifications, the tenderer should address all such options. Wherever specifically mentioned by us, the tenderer could suggest changes to specifications with appropriate response

for the same.

23. The tenderer should supply along with his tender, the name of his bankers as well as the latest Income-Tax clearance certificate duly countersigned by the Income-Tax Officer of the Circle concerned under the seal of his office, if required by the Purchaser.
24. The contractor shall also undertake the supply of additional number of items covered by the order as considered necessary by the purchaser at a later date, the actual price to be paid shall be mutually agreed to after negotiations.
25. Subletting and Assignment: The contractor/supplier cannot sublet, transfer or assign the order/Contract or any part thereof or interests therein or benefit or advantage thereof in any manner whatsoever, to any other party without written consent of the purchaser. Such consent by the purchaser, however, shall not relieve or discharge the contractor/supplier from any obligation, duty or responsibility under the Purchase Order/ Contract.
26. The contractor/supplier shall indemnify the purchaser against Workmen Compensation Act.
27. The authority of the person submitting the tender, if called for, should be produced.

PROCEDURE FOR EVALUATION OF TENDERS:

Technical Evaluation Criteria:

Vendor meeting the eligibility criteria and basic technical specifications mentioned in SCL Tender are likely to be considered to be technically qualified.

Evaluation of Financial Bids:

The following elements shall be considered for evaluation of Price Bids:

- a. Price quoted by the bidder in the price bid template is for meeting the functionalities given in the Tender and Technical Specifications sheet.
- b. In case quotations are submitted in foreign currencies, during preparation of price tabulation, Foreign Exchange (FE) conversion rate vis-a-vis Indian currency (INR) will be worked out on the basis of FE TT selling rate prevailing on the day of opening of technical bids.
- c. Compliance with the Payment Terms prescribed in this tender document. In the event, the bidder offers Payment Terms stringent than SCL prescribed Payment Terms, the bid of the bidder shall be loaded as per prime lending rate of Reserve Bank of India (RBI) and added to the landed cost.
- d. In the event of the bidder requiring SCL to bear bank charges outside India (foreign bank charges), the bidders bid shall be loaded suitably on the quoted price towards bank charges outside India.
- e. In case, the price quoted is FCA/FOB/Ex-works, the charges towards Freight as quoted or a maximum of 5% of price quoted, Customs Duty taxes as applicable shall be taken into account to arrive landed cost.
- f. Comparison between Indigenous Imported Offers: If both indigenous offers and imported offers are to be compared, 2% of the total landed cost of foreign offers shall be added towards charges for Customs clearance and local transportation for delivery at SCL.

Commercial Terms Conditions to Tender Ref. No.: 45185

Filled up response fully stamped and signed by authorized bidder to be scanned and uploaded in Technical part Cover-1 only

Sr. no	Description	Vendor's Compliance
1.	<p>DEFINITIONS:</p> <p>a. The term PURCHASER shall mean Semi-Conductor Laboratory, Sector-72, Mohali, Punjab 160071, under the administrative control of MEITY, Government of India.</p> <p>b. The term CONTRACTOR shall mean, the person, firm or company with whom or with which the order for the supply of stores is placed and shall be deemed to include the Contractors successors, representative, heirs, executors and administrators unless excluded by the Contract.</p> <p>c. The term STORES shall mean what the Contractor agrees to supply under the Contract as specified in the Purchase Order including erection of plants machinery and subsequent testing, should such a condition is included in the Purchase Order. The term PURCHASE ORDER shall mean the communication signed on behalf of the Purchaser by an Officer duly authorised intimating the acceptance on behalf of the Purchaser on the terms and conditions mentioned or referred to in the said communication accepting the tender or offer of the Contractor for supply of stores or plant, machinery or equipment or part thereof.</p>	
2.	<p>Being a Two Part Tender Technical and Commercial part are separate. The Technical part (Cover-1) should not contain any Pricing information.</p> <p>The tenders containing Price details in Technical part (Cover-1) will be summarily rejected.</p> <p>The prices should be quoted in Price-Bid Form BOQ and to be uploaded in BOQ-Commercial (Cover-2) only.</p>	
3.	<p>The Vendor / Contractor shall confirm that they have submitted the offer for NEW Items only.</p>	
4.	<p>OEM or authorised distributor/representatives of OEM can participate in the tender and an authorisation certificate/letter from OEM to be submitted alongwith the Cover-I of the bid.</p>	
5.	<p>Eligibility Criteria: Vendor or their OEM should have earlier supplied similar sealing windows and should produce supporting document/s.</p>	
6.	<p>Compliance/acceptance to :</p> <p>I. Material Specifications attached as Annexure-I. Vendor shall provide compliance duly signed stamped and the same should be submitted alongwith the Cover-I of the bid i.e. technical bid.</p> <p>II. No price to be mentioned in Technical part/alongwith technical bid.</p>	

	<p>III. Tender Acceptance Letter.</p> <p>IV. BOQ in xls. and as well as signed, stamped and scanned copy.</p> <p>V. The bids have to be submitted online in electronic form on www.eprocure.gov.in only.</p> <p>VI. No physical bids will be accepted.</p>	
7.	<p>Earnest Money Deposit (EMD): Bidders are required to submit offers along with prescribed Earnest Money Deposit (EMD) amount of Rs.3,00,000.00 (Rupees Three lakh only) as per details in the tender. EMD instrument in original should be sent in a sealed cover with a covering letter quoting tender number and same must reach us prior to due date of tender. The scanned copy of EMD instrument should be attached online with the tender</p>	
8.	<p>Validity of Bid: The offer should be valid for a minimum period of 120 from the date of opening of Tehno-Commercial bid and 90 days after opening of Price Bid.</p>	
9.	<p>Delivery Terms (For imported stores): Prices shall be quoted on FOB/FCA nearest International/Gateway airport basis inclusive of all taxes, levies, duties arising in the tenderer country.</p>	
10.	<p>Export Formalities, Taxes & Duties: Any export approvals/Govt. clearances required, Taxes and duties as per laws of the exporting country shall be the responsibility of Vendor. Any Govt. formalities/ Clearances required, Taxes and duties etc. payable as per Indian Laws shall be PURCHASERS responsibility.</p>	
11.	<p>Delivery Terms (For Indigenous stores): Prices shall be quoted on F.O.R. destination basis i.e. SCL, S.A.S. Nagar, Mohali, Punjab exclusive of GST as may be applicable.</p>	
12.	<p>For imported materials: Vendors who are offering the delivery term as DDP/FOR basis, please note that, Purchaser is eligible to issue Customs duty exemption certificate (CDEC) to the contractor under customs notification no.45/25 dated 24.10.2025 and subsequent amendments to enable the contractor to avail off the benefit of concessional rate of customs duty under this notification. Under this notification Basic Customs Duty shall be applicable at the rate 5.5 percent plus GST as applicable. While offering the price, vendor shall take into consideration the same.</p> <p>In addition to the above CDEC, any documentary support requested by the contractor from the purchaser for customs clearance of goods against the above CDEC shall be provided by the purchaser.</p> <p>(Purchaser will provide Customs Duty Exemption Certificate in case of Import Orders/ imported supplies/ High Sea Sales).</p>	
13.	<p>Goods and Service Tax (GST (for Indigenous Stores): GST if applicable please mention percentage of GST along with HSN Code in your response.</p>	

14.	Delivery schedule: Vendor shall provide the delivery of the material within 4 months from PO.	
15.	<p>Security Deposit (SD): On acceptance of the tender, the Vendor shall submit security deposit for three percent (3.0% percent) value of the Purchase Order (PO) within 15 days from the date of PO towards successful execution of the PO. Security Deposit shall be submitted through Demand Draft /Bankers Cheque/ fixed deposit receipt or Bank Guarantee from any of the Scheduled Banks executed on non-judicial stamp paper of appropriate value, and shall be valid till execution of PO and should remain valid for a period of sixty (60) days beyond the date for completion of the Purchase Order. This will be returned by SCL immediately on execution of the PO satisfactorily as per order terms. If not, the amount will be forfeited.</p> <p>Note: In case, Security Deposit is submitted in the form of Bank Guarantee (BG) and Issuing Bank utilizes SFMS (Structured Financial Messaging Solution) Gateway for issuing the BG in favour of SCL and mention IFSC code of SCL banker i.e. State Bank of India, SBIN00061229, genuineness of the BG will be verified by SCL's banker by checking into SFMS gateway.</p> <p>In case, Security Deposit is submitted in the form of Bank Guarantee (BG) and Issuing Bank not utilizes SFMS (Structured Financial Messaging Solution) Gateway for issuing the BG, Vendor to ensure that Banker gives Bank Guarantee (BG) confirmation over email from their Domain immediately after issuance of the same at the following email Ids followed by hard copy:</p> <p>uday@scl.gov.in / uday-reddy@scl.gov.in CC: naresh@scl.gov.in , surendra.kumar@scl.gov.in and vmehta@scl.gov.in</p> <p>In addition, the banker may send a scanned copy of the BG as an attachment.</p>	
16.	<p>Terms of Payment in case of overseas supplier(s): 100% payment shall be made through SIGHT DRAFT after shipment. Vendor is requested to send the original documents (i.e Invoice, Packing List, AWB or BL etc.) to PURCHASER BANKER routed through VENDOR BANK for payment at the following address:</p> <p>State Bank of India(61229) Semi-Conductor Laboratory Sector 72, Mohali, Punjab - 160071, INDIA.</p>	
17.	Bank Charges: All bank charges outside India related to the payment shall be borne by the Contractor and all bank charges in India shall be borne by the purchaser.	
18.	Terms of payment in case of Indigenous supplier(S): 100% payment shall be made for the accepted stores with 30 days from the date of receipt and acceptance of the materials at SCL.	

19.	<p>Tax Deducted At Source (TDS) for overseas supplier (s): Tooling cost / NRE Charges, if applicable shall be payable after deduction of TDS as per Indian Income Tax Act 1961 with latest amendments thereof, if the vendor has permanent establishment in India. Vendor shall also certify whether they have valid PAN issued by Income Tax Department of India. If the vendor has not permanent establishment in India, TDS shall be deducted as Double Taxation Avoidance Agreement.</p>	
20.	<p>Delay in Completion/Liquidated Damages (LD): If the Contractor fails to deliver the stores within the time specified in the Contract or any extension thereof, the purchaser shall recover from the Contractor as liquidated damages a sum of one-half of one percent (0.5 percent) of the undelivered stores for each calendar week of delay. The total liquidated damages shall not exceed ten percent (10 percent) of the Contract price of the unit or units so delayed.</p>	
21.	<p>Extension of Time: If the completion of supply of stores is delayed due to reason of force majeure such as acts of god, acts of public enemy, acts of Government, fires, floods, epidemics, quarantine restriction, strikes, freight embargoes, etc., the Contractor shall give notice within 15 days to the purchaser in writing of his claim for an extension of time. The purchaser on receipt of such notice after verification, if necessary, may agree to extend the Contract delivery date as may be reasonable but without prejudice to other terms and conditions of the Contract.</p>	
22.	<p>Mode of Despatch:</p> <p>(i) Overseas Supplier, stores should be despatched by Indian Flag Vessels/Air India or through any Agency nominated by SCL whose contact details shall be indicated in the purchase order.</p> <p>(ii) Indigenous orders: Vendor responsibility.</p>	
23.	<p>Packing and Forwarding: The Contractor will be held responsible for the stores being sufficiently and properly packed for transport by rail, road, sea or air to withstand transit hazards and ensure safe arrival at the destination. The packing and marking of packages shall be done by and at the expense of the Contractor. The purchaser will not pay separately for transit insurance, all risks in transit being exclusively of the Contractor and the Purchaser shall pay only for such stores as are actually received in good condition in accordance with the Contract.</p>	
24.	<p>Fall Clause: The prices charged for the stores supplied under the Contract by the vendor should in no event exceed the lowest price at which the vendor sells the stores of identical description to any other person during the period of the Contract. If at any time, the prices are reduced, the same shall be notified to the Purchaser and shall stand correspondingly reduced.</p>	
25.	<p>Rejection: In the event that any of the stores supplied by the Contractor is found defective in material or workmanship or otherwise not in conformity with the requirements of the Contract specifications, the purchaser shall either reject the stores or request the Contractor, in writing, to rectify the same. The Contractor, on receipt of such notification, shall either rectify or replace the defective stores free of cost to the purchaser.</p>	

26.	<p>Replacement: If the stores or any portion thereof is damaged or lost during transit, the Purchaser shall give notice to the Contractor setting forth particulars of such stores damaged or lost during transit. The replacement of such stores shall be effected by the contractor within a reasonable time to avoid unnecessary delay in the intended usage of the Stores. In case the purchaser agrees, the price towards replacement items shall be paid by the purchaser on the basis of original price quoted in the tender or as reasonably worked out from the tender.</p>	
27.	<p>Arbitration: In the event of any dispute/s, difference/s or claim/s arising out of or relating to the interpretation and application of the Contract, such dispute/s or difference/s or claim/s shall be settled amicably by mutual consultations of the good Offices of the respective Parties and recognizing their mutual interests attempt to reach a solution satisfactory to both the parties. If such a resolution is not possible, within 30 days from the date of receipt of written notice of the existence of such dispute/s, then the unresolved dispute/s or difference/s or claim/s shall be referred to the Sole Arbitrator appointed by the Parties by mutual consent in accordance with the rules and procedures of Arbitration and Conciliation Act 1996 as amended from time to time. The arbitration shall be conducted in New Delhi in the Arbitration and Conciliation Centre, New Delhi (Domestic and International) as per its rules and regulations. The expenses for the Arbitration shall be shared equally or as may be determined by the Arbitrator. The considered and written decision of the Arbitrator shall be final and binding between the Parties. The applicable language for Arbitration shall be English only.</p> <p>Work under the Contract shall be continued by the CONTRACTOR during the pendency of arbitration proceedings, without prejudice to a final adjustment in accordance with the decision of the Arbitrator unless otherwise directed in writing by the DEPARTMENT or unless the matter is such that the works cannot be possibly continued until the decision (whether final or interim) of the Arbitrator is obtained.</p>	
28.	<p>Applicable Law: The Contract shall be interpreted, construed and governed by the laws of India. The contract shall be subject to exclusive jurisdiction of the Court of S.A.S. Nagar (Mohali), Punjab irrespective of anything mentioned in any correspondence or otherwise.</p>	
29.	<p>(i) Whether the Vendor / Supplier is from any country sharing land boundary with India or whether the vendor / supplier is representing any principal vendor /principal supplier sharing land boundary with India.</p> <p>(ii) If the vendor / supplier is from any country which shares land border with India or if the vendor /supplier is and Indian Agent representing principal vendor/principal supplier of a country which shares land border with India they need to submit a photo copy documentary proof of Registration with Registration Committee constituted by Department of promotion of Internal Industry and Trade (DPIIT).</p> <p>The provision of following Orders issued by Department of Expenditure, Ministry of Finance are applicable in this regard:</p> <p>(a) Order (Public Procurement No. 1) Nos. 6/182019-PPD dt.July 23rd , 2020.</p> <p>(b) Order (Public Procurement No.2) Nos.6/182019-PPD dt July 24th , 2020 on clarification to order (Public Procurement No.1) dt. July 23rd , 2020.</p> <p>(iii) Offer received from vendor who fall in this category but does not submit</p>	

	copy of documentary proof of registration shall be rejected.	
30.	<p>The participating Indian Vendors/Suppliers/Service Providers shall indicate specifically whether they fall in the category of Class I local supplier or Class II local supplier or Nonlocal supplier for evaluation as per Ministry of Commerce Industry office order no. P45021/2/2017PP(BEII)-Part(4)Vol.II dt. 19th July, 2024.</p> <p>The vendor/supplier/Service Provider shall submit declaration as documentary proof in this regard.</p> <p>The provision of above referred OM shall apply for this procurement. Purchase preference shall be Governed by the above mentioned orders and subsequent orders issued from time to time.</p>	
31.	Indian agent remuneration/service charge (If applicable) shall be payable by the Purchaser directly to the Indian agent in Indian Rupees based on T.T buying rate of exchange prevailing on the date of placement of purchase order within 30 days of acceptance of material at purchaser site.	
32.	Indicate the Name and address of the vendor for placing purchase order along with their e-mail ID, contact person name and designation, Telephone no. and fax no.	
33.	Any Other Term:	

Yours Faithfully,
(Signature of the Bidder, with Official Seal)

STANDARD TERMS AND CONDITIONS (FOR IMPORTED STORES)

1. **DEFINITIONS:**
 - a) The term 'Purchaser' shall mean the President of India or his successors or assignees.
 - b) The term 'Contractor' shall mean, the person, firm or company with whom or with which the order for the supply of stores is placed and shall be deemed to include the Contractor's Successors, representatives, heirs, executors and administrators unless excluded by the Contract.
 - c) The term 'Purchase Order' shall mean the communication signed on behalf of the Purchaser by an officer duly authorized intimating the acceptance on behalf of the Purchaser on the terms and conditions mentioned or referred to in the said communication accepting the Tender or offer of the Contractor for supply of stores of plant, machinery or equipment of part thereof.
 - d) The term 'Stores' shall mean what the Contractor agrees to supply under the Contract as specified in the Purchase Order.
2. **PRICES:** Tenders offering firm prices will be preferred. Where a price variation clause is insisted upon by a tenderer, quotations with a reasonable ceiling should be submitted. Such offers should invariably be supported by the base price taken into account at the time of tendering and also the formula for any such variations.
3. **IMPORTANT LICENCE:** Reference to Import License No. & date and Contract number & date shall be prominently indicated in all the documents .
4. **DEMURRAGE:** Supplier shall bear demurrage charges, if any, incurred by the purchaser due to delayed presentation of shipping documents as prescribed in the tender to the bankers within a reasonable time (say within 10-12 days) from the date of bill of lading for sea consignments and within 3-4 days from the date of Air Way Bill for air consignments.
5. **GUARANTEED TIME DELIVERY:** The time for and the date of delivery stipulated in the Purchase Order shall be deemed to be the essence of the Contract. Delivery must be completed within the date specified therein.
6. **INSPECTION AND ACCEPTANCE TEST:**
 - 6.1. The Purchaser's representatives shall also be entitled at all reasonable times during manufacture to inspect, examine and test on the Contractor's premises the material and workmanship of all stores to be supplied under this Contract and if part of the said stores is being manufactured on other premises, the Contractor shall

obtain for the purchaser's representative permission to inspect, examine and test as if the equipment were being manufactured on the Contractor's premises. Such inspection, examination and testing shall not release the Contractor from the obligations under this Contract.

6.2. For tests on the premises of the Contractor or of any of his sub-Contractors, the Contractor shall provide free of cost assistance, labour, material, electricity, fuel and instruments as may be required or as may be reasonably needed by the purchaser's representative to carry out the tests efficiently.

6.3. When the stores have passed the specified test, the purchaser's representative shall furnish a certificate to the effect in writing to the Contractor. The Contractor shall provide copies of the test/s certificates to the purchaser as may be required.

7. CONSIGNEE: Purchase & Stores Officer (Main Stores), Semi-Conductor Laboratory, Sector 72, S.A.S. Nagar (Mohali), Punjab, India - 160 071

8. SHIPPING MARKS: The mark on the shipping documents such as invoice, bill of lading and on the packages should be as follow:

PURCHASE ORDER NO. DATED
Semi-Conductor Laboratory, Ministry of Electronics & Information Technology,
Govt. of India, Sector 72, S.A.S. Nagar (Mohali), Punjab,
India - 160 071

Destination: & Port of Entry:

9. INSURANCE OF THE STORES: The necessity or otherwise of insurance will be as indicated in the Purchase Order.

10. CONTRACTOR'S DEFAULT LIABILITY: The purchaser may upon written notice of default to the Contractor terminate the Contract in whole or in part in circumstances detailed hereunder:

a) If in the judgement of the Purchaser the Contractor fails to make delivery of Stores within the time specified in the Contract/agreement or within the period for which extension has been granted by the Purchaser to the Contractor.

b) If in the judgment of the Purchaser the Contractor fails to comply with any of the other provisions of this Contract.

11. In the event the Purchaser terminates the Contract in whole or in part as provided in the tender the Purchaser reserves the right to Purchase, upon such terms and in such a manner as he may deem appropriate, stores similar to that terminated and the Contractor shall be liable to the Purchaser for any additional costs for such similar stores and/or for liquidated damages for delay as defined in the tender until such reasonable time as may be required for the final supply of stores.

11.1 If this Contract is terminated as provided in the tender the Purchaser in addition to any other rights provided in this Article, may require the Contractor to transfer title and deliver to the Purchaser under any of the following clauses in the manner and as directed by the Purchaser:

- a) Any completed stores.
- b) Such partially completed stores, drawing, information and Contract rights (hereinafter called manufacturing material) as the Contractor has specifically produced or acquired for the performance of the Contract as terminated. The Purchaser shall pay to the Contractor the Contract price for completed stores delivered to and accepted, by the purchaser and for manufacturing material delivered and accepted.

11.2 In the event the Purchaser does not terminate the Contract as provided in the tender, the Contractor shall continue the performance of the Contract in which case he shall be liable to the purchaser for liquidated damages for delay as set out in the tender until the stores are accepted.

12. GUARANTEE & REPLACEMENT:

- a) The Contractor shall guarantee that the stores supplied shall comply fully with the specifications laid down for material, workmanship and performance.
- b) For a period of twelve months (12) after the acceptance of the stores, if any defects are discovered therein or any defects therein are found to have developed under proper use arising from faulty materials, design or workmanship, the Contractor shall remedy such defects at his own cost provided he is called upon to do so within a period of 26 months from the date of acceptance thereof by the Purchaser who shall state in writing in what respect the stores or any parts thereof are faulty.
- c) If in the opinion of the purchaser it becomes necessary to replace or renew any defective stores, such replacements or renewals shall be made by the Contractor free of all costs to the purchaser provided the notice informing the Contractor of the defect is given by the purchaser in this regard within the said period of 26 months from the date of acceptance thereof.
- d) Should the Contractor fail to rectify the defects, the purchaser shall have the right to reject or repair or replace at the cost of the Contractor the whole or any portion of the defective stores.
- e) The decision of the Purchaser, notwithstanding any prior approval or acceptance or inspection thereof on behalf of the purchaser, as to whether or not the stores supplied by the Contractor are defective or any defects has developed within the said period of 24 months or as to whether the nature of the defects requires renewal or replacement shall be final, conclusive and binding on the Contractor.
- f) To fulfill guarantee conditions outlined in Clause 12 (a) to (e) above, the Contractor shall, at the option of the purchaser, furnish a Bank Guarantee (as prescribed by the purchaser - Bank Guarantee format enclosed) from a Bank approved by the purchaser for an amount equivalent to 03% of the value of the Contract along with first shipment documents. On the performance and completion of the Contract in all respects, the Bank Guarantee will be returned to the Contractor without any interest.
- g) All the replacement stores shall also be guaranteed for a period of 24 months from the date of arrival of stores at purchaser's site.
- h) Even while the 24 months guarantee applies to all stores, in case where a greater period is called for by our specifications, then such a specification shall apply, and in such cases, the period of 26 months referred to in Clause 12 (b) and (c) shall be asked for guarantee period plus two months.

13. REQUIREMENT OF ADDITIONAL NUMBERS OF THE STORES/SPARE PARTS ORDERED: The Contractor shall also undertake the supply of additional number of items covered by the order as considered necessary by the purchaser at a later date, the actual price to be paid shall be mutually agreed to after negotiations.

14. PACKING:

- a) The Contractor wherever applicable shall pack and crate all stores for sea /air shipment as applicable in a manner suitable for export to a tropical humid climate, in accordance with internationally accepted export practices and in such a manner so as to protect it from damage and deterioration in transit by road, rail or sea for space qualified stores. The Contractors shall be held responsible for all damages due to improper packing.
- b) The Contractor shall ensure that each box / unit of shipment is legible and properly marked for correct identification. The failure to comply with this requirement shall make the Contractor liable for additional expenses involved.
- c) The Contractor shall notify the purchaser of the date of shipment from the port of embarkation as well as the expected date of arrival of such shipment at the designated port of arrival.
- d) The Contractor shall give complete shipment information concerning the weight, size, content of each packages, etc.
- e) Transshipment of equipment shall not be permitted except with the written permission of the purchaser.
- f) Apart from the despatch documents negotiated through Bank, the following documents shall also be airtailed to the purchaser within 7 days from the date of shipment by sea and within 3 days in case of air-consignments:
- g) Commercial Bill of Lading / Air Way Bill / Post parcel Receipt. (Two non-negotiable copies)
 - b) Invoice (3 copies)
 - c) Packing List (3 copies)
 - d) Test Certificate (3 copies)
 - e) Certificate of Origin.

The Contractor shall also ensure that one copy of the packing list is enclosed in each case.

15. LANGUAGE AND MEASURES: All documents pertaining to the Contract including specification, schedule, notice, correspondence, operating and maintenance instructions, drawings or any other writings shall be written in English language. The metric system of measurement shall be used exclusively in the Contract.

16. INDEMNITY: The Contractor shall warrant and be deemed to have warranted that all Stores supplied against this Contract are free and clean of infringement of any patent, copyright or trade mark and shall at all times indemnify the purchaser against all claims which may be made in respect of stores for infringement of any right protected by Patent, Registration of design or Trade Mark, and shall take all risk of accident or damage which may cause a failure of the supply from whatever cause arising and the entire responsibility for the sufficiency of all the means used by him for the fulfillment of the Contract.

17. COUNTER TERMS AND CONDITIONS OF SUPPLIERS: Where counter terms and conditions/printed or cyclostyled conditions have been offered by the supplier, the same shall not be deemed to have been accepted by the purchaser unless specific written acceptance thereof is obtained.
18. SECURITY INTEREST: On each item to be delivered under this Contract, including an item of work in progress in respect of which payments have been made in accordance with the terms of the Contract, purchaser shall have a security interest in such items which shall be deemed to be released only at the time when the applicable deliverable item is finally accepted and delivered to the purchaser in accordance with the terms of the Contract. Such security interest of the purchaser shall constitute a prior charge as against any other charge or interest created in respect of such items by any entity.

STANDARD TERMS AND CONDITIONS FOR INDIGENOUS STORES

1. DEFINITIONS:

- (a) The term PURCHASER shall mean the Director, SCL or his successors or assigns.
- (b) The term CONTRACTOR shall mean, the person, firm or company with whom or with which the order for the supply of stores is placed and shall be deemed to include the Contractor's successors, representative, heirs, executors and administrators unless excluded by the Contract.
- (c) The term STORES shall mean what the Contractor agrees to supply under the Contract as specified in the Purchase Order including erection of plants machinery and subsequent testing, should such a condition is included in the Purchase Order.
- (d) The term PURCHASE ORDER shall mean the communication signed on behalf of the Purchaser by an Officer duly authorised intimating the acceptance on behalf of the Purchaser on the terms and conditions mentioned or referred to in the said communication accepting the tender or offer of the Contractor for supply of stores or plant, machinery or equipment or part thereof.

2. PRICES: Tender offering firm prices will be preferred. Where a price variation clause is insisted upon by a tenderer, quotation with a reasonable ceiling should be submitted. Such offers should invariably be supported by the base price taken into account at the time of tendering and also the formula for any such variation/s.

3. SECURITY DEPOSIT: On acceptance of the tender and placement of order, the Contractor shall, at the option of the Purchaser and within the period specified by him, deposit with him, in cash or in any other form as the Purchaser may determine, security deposit not exceeding three percent of the value of the Contract as the Purchaser shall specify. If the Contractor is called upon by the Purchaser to deposit, Security and the Contractor fails to provide the security within the period specified, such failure shall constitute a breach of the Contract, and the Purchaser shall be entitled to make other arrangements for the re-purchase of the stores contracted at the risk of the Contractor in terms of the tender and/or to recover from the Contractor, damages arising from such cancellation.

4. ~~GUARANTEE REPLACEMENT:~~

(a) The Contractor shall guarantee that the stores supplied shall comply fully with the specifications laid down, for material, workmanship and performance.

(b) For a period of **12 months** after the acceptance of the stores, if any defects are discovered therein or any defects therein found to have developed under proper use, arising from faulty stores design or workmanship, the Contractor shall remedy such defects at his own cost provided he is called upon to do so within a period of **14 months** from the date of acceptance thereof by the purchaser who shall state in writing in what respect the stores or any part thereof are faulty.

(c) If, in the opinion of the purchaser, it becomes necessary to replace or renew any defective stores such replacement or renewal shall be made by the Contractor free of all costs to the purchaser, provided the notice informing the Contractor of the defect is given by the purchaser in this regard within the said **period of 12 months** from the date of acceptance thereof.

(d) Should the Contractor fail to rectify the defects, the purchaser shall have the right to reject or repair or replace at the cost of the Contractor the whole or any portion of the defective stores.

(e) The decision of the purchaser notwithstanding any prior approval or acceptance or inspection thereof on behalf of the purchaser, as to whether or not the stores supplied by the Contractor are defective or any defect has developed within the said period of **12 months** or as to whether the nature of the defects requires renewal or replacement, shall be final, conclusive and binding on the Contractor.

(f) To fulfil guarantee conditions outlined in the tender, the Contractor shall, at the option of the purchaser, furnish a Bank Guarantee (as prescribed by the purchaser) from a Bank approved by the purchaser for an amount equivalent to 3% of the value of the Contract along with first shipment documents. On the performance and completion of the Contract in all respects, the Bank Guarantee will be returned to the Contractor without any interest.

(g) All the replacement stores shall also be guaranteed for a period of **12 months** from the date of arrival of the stores at purchaser's site.

(h) Even while **the 12 months** guarantee applies to all stores, in case where a greater period is called for by our specifications then such a specification shall apply in such cases the period of **14 months** referred to in **para 4 (b) (c)** shall be the asked for guarantee period plus two months.

5. **PACKING FORWARDING INSURANCE:** The Contractor will be held responsible for the stores being sufficiently and properly packed for transport by rail, road, sea or air to withstand transit hazards and ensure safe arrival at the destination. The packing and marking of packages shall be done by and at the expense of the Contractor. The purchaser will not pay separately for transit insurance, all risks in transit being exclusively of the Contractor and the Purchaser shall pay only for such stores as are actually received in good condition in accordance with the Contract.

6. **DESPATCH:** The Contractor is responsible for obtaining a clear receipt from the Transport Authorities specifying the goods dispatched. The consignment should be

dispatched with clear Railway Receipt/Lorry Receipt. If sent in any other mode, it shall be at the risk of the Contractor. Purchaser will take no responsibility for short deliveries or wrong supply of goods when the same are booked on said to contain basis. Purchaser shall pay for only such stores as are actually received by them in accordance with the Contract.

7. TEST CERTIFICATE: Wherever required, test certificates should be sent along with the dispatch documents.

8. ACCEPTANCE OF STORES:

(a) The stores shall be tendered by the Contractor for inspection at such places as may be specified by the purchaser at the Contractor's own risk, expense and cost.

(b) It is expressly agreed that the acceptance of the stores Contracted for, is subject to final approval by the purchaser, whose decision shall be final.

(c) If, in the opinion of the purchaser, all or any of the stores do not meet the performance or quality requirements specified in the Purchase Order, they may be either rejected or accepted at a price to be fixed by the purchaser and his decision as to rejection and the prices to be fixed shall be final and binding on the Contractor.

(d) If the whole or any part of the stores supplied are rejected in accordance with Clause No. 8 (c) above, the purchaser shall be at liberty, with or without notice to the Contractor, to purchase in the open market at the expense of the Contractor stores meeting the necessary performance and quality Contracted for in place of those rejected, provided that either the purchase, or the agreement to purchase, from another supplier is made within six months from the date of rejection of the stores as aforesaid.

9. REJECTED STORES: Rejected stores will remain at destination at the Contractor's risk and responsibility. If instructions for their disposal are not received from the Contractor within a period of 14 days from the date of receipt of the advice of rejection, the purchaser or his representative has, at his discretion, the right to scrap or sell or consign the rejected stores to Contractor's address at the Contractor's entire risk and expense, freight being payable by the Contractor at actuals.

10. DELIVERY:

(a) The time for and the date of delivery of the stores stipulated in the Purchase Order shall be deemed to be the essence of the Contract and delivery must be completed on or before the specified dates.

(b) Should the Contractor fail to deliver the stores or any consignment thereof within the period prescribed for such delivery, the purchaser shall be entitled at his option either.

(i) to recover from the Contractor as agreed liquidated damages and not by way of penalty, a sum of 0.5% per week of the price of any stores which the Contractor has failed to deliver as aforesaid or during which the delivery of such store may be in arrears subject to a minimum of 10%, or

(ii) to purchase from elsewhere, without notice to the Contractor on the account and at the risk of the Contractor, the stores not delivered or others of a similar description (where others exactly complying with the particulars, are not, in the opinion of the purchaser, readily procurable, such opinion being final) without cancelling the Contract in respect of the consignment (s) not yet due for delivery, or

- (iii) to cancel the Contract or a portion thereof and if so desired to purchase or authorise the purchase of stores not so delivered or others of a similar description (where others exactly if complying with the particulars are not, in the opinion of the purchaser, readily procurable, such opinion final) at the risk and cost of the Contractor.

In the event of action being taken under sub-**clause (ii) (iii) of clause 10 (b)** above, the Contractor shall be liable for any loss which the purchaser may sustain on that account, provided that the re-purchase or if there is an agreement to repurchase then such agreement is made within six months from the date of such failure. But the Contractor shall not be entitled to any gain on such re-purchase made against default. The manner and method of such re purchase shall be at the discretion of the purchaser, whose decision shall be final. It shall not be necessary for the purchaser to serve a notice of such re purchase on the defaulting Contractor. This right shall be without prejudice to the right of the purchaser to recover damages for breach of Contract by the Contractor.

11. **EXTENSION OF TIME:** As soon as it is apparent that the Contract dates cannot be adhered to, an application shall be sent by the Contractor to the purchaser. If failure, on the part of the Contractor, to deliver the stores in proper time shall have arisen from any cause which the purchaser may admit as reasonable ground for an extension of the time (and his decision shall be final) he may allow such additional time as he considers it to be justified by circumstances, of the case without prejudice to the purchaser's right to recover liquidated damages.
12. **ERECTION OF PLANT MACHINERY:** Wherever erection of a plant or machinery is the responsibility of the Contractor as per the terms of the Contract and in case the Contractor fails to carry out the erection as and when called upon to do so within the period specified by the purchaser, the purchaser shall have the right to get the erection done through any source of his choice. In such an event, the Contractor shall be liable to bear any additional expenditure that the purchaser is liable to incur towards erection. The Contractor shall, however, not be entitled to any gain due to such an action by the purchaser.
13. **PAYMENT:** Contractor's bill will be passed for payment only after the stores have been received, inspected and accepted by the Purchaser.
14. **RECOVERY OF SUM DUE:** Whenever any claim for the payment of, whether liquidated or not, money arising out of or under this Contract against the Contractor, the purchaser shall be entitled to recover such sum by appropriating in part or whole, the security deposited by the Contractor, if a security is taken against the Contract. In the event of the security being insufficient or if no security has been taken from the Contractor, then the balance or the total sum recoverable as the case may be, shall be deducted from any sum then due or which at any time thereafter may become due to the Contractor under this or any other Contract with the purchaser. Should this sum be not sufficient to cover the full amount recoverable, the Contractor shall pay to the purchaser on demand the remaining balance due. Similarly, if the purchaser has or makes any claim, whether liquidated or not, against the Contractor under any other Contract with the purchaser, the payment of all moneys payable under the Contract to the Contractor including the security deposit shall be withheld till such claims of the purchaser are finally adjudicated upon and paid by the Contractor.
15. **INDEMNITY:** The Contractor shall warrant and be deemed to have warranted that all stores supplied against this Contract are free and clean of infringement of any Patent, Copyright or Trademark, and shall at all times indemnify the purchaser against all claims

which may be made in respect of the stores for infringement of any right protected by Patent Registration of design or Trade mark and shall take all risk of accidents or damage which may cause a failure of the supply from whatever cause arising and the entire responsibility for sufficiency of all means used by him for the fulfilment of the contract.

16. COUNTER TERMS AND CONDITION OF SUPPLIERS: Where counter terms and conditions printed or cyclostyled conditions have been offered by the supplier, the same shall not be deemed to have been accepted by the Purchaser, unless specific written acceptance thereof is obtained.
17. SECURITY FOR PURCHASE OF MATERIALS: Successful tenderer will have to furnish in the form of a bank guarantee or any other form as called for by the purchaser towards adequate security for the materials and properties provided by the Purchaser for the due execution of the Contract.

Compliance for technical Specifications

Sl. No.	Technical Specifications	Vendor's Compliance
1.	Technical Specifications for Sealing Window for Imager-2 and Imager-3 as per attached Annexure-I	

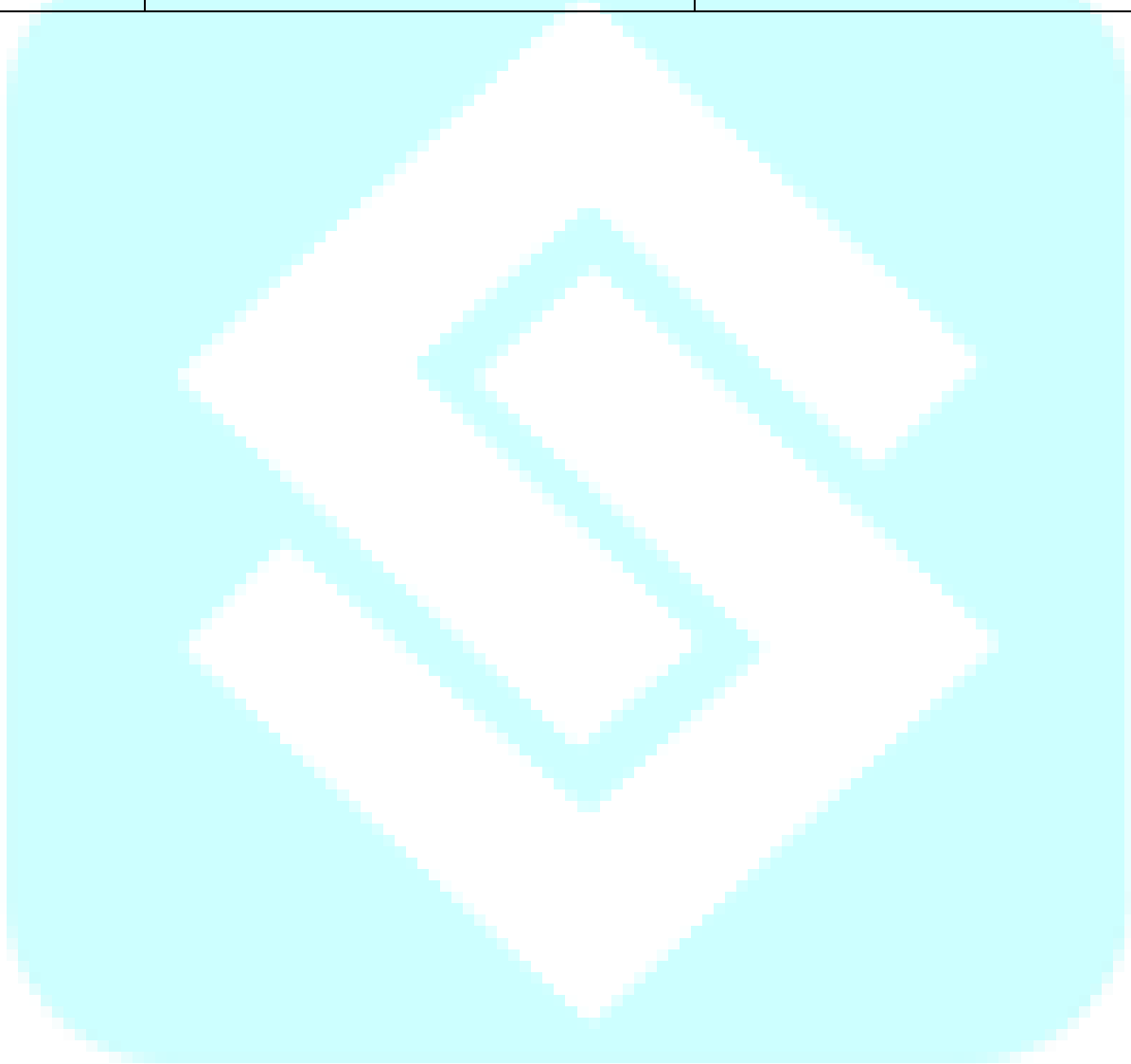

1. Window specifications:

Scope includes Fused Silica window with ARC coating on both sides. Qualification and acceptance test requirements are mentioned in section 1.2 and section 3. Drawing for the window shall be finalized after PO placement.

1.1. Physical and Optical Parameters of Optical Window

Fused silica substrates should be used to fabricate optical windows. Broadband anti-reflection (AR) coating (400 nm – 1100 nm) should be applied uniformly on both sides of the substrates. Figure 1 shows the schematic of the optical windows for Imager-2. The optical window should withstand a thermal environment from -55°C to $+125^{\circ}\text{C}$ without affecting the performance when brought to Lab. ambient ($23 \pm 5^{\circ}\text{C}$).

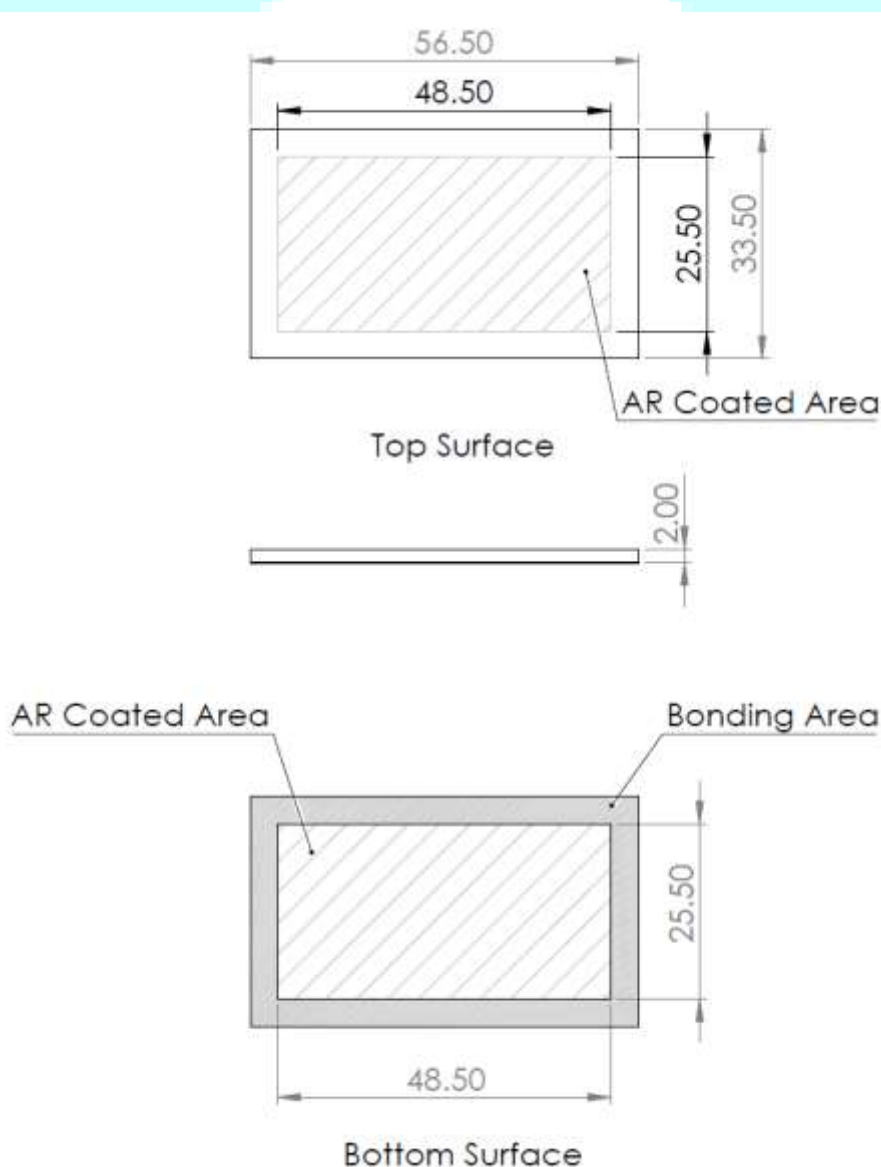

Figure 1: Schematic of the optical window for Imager-2

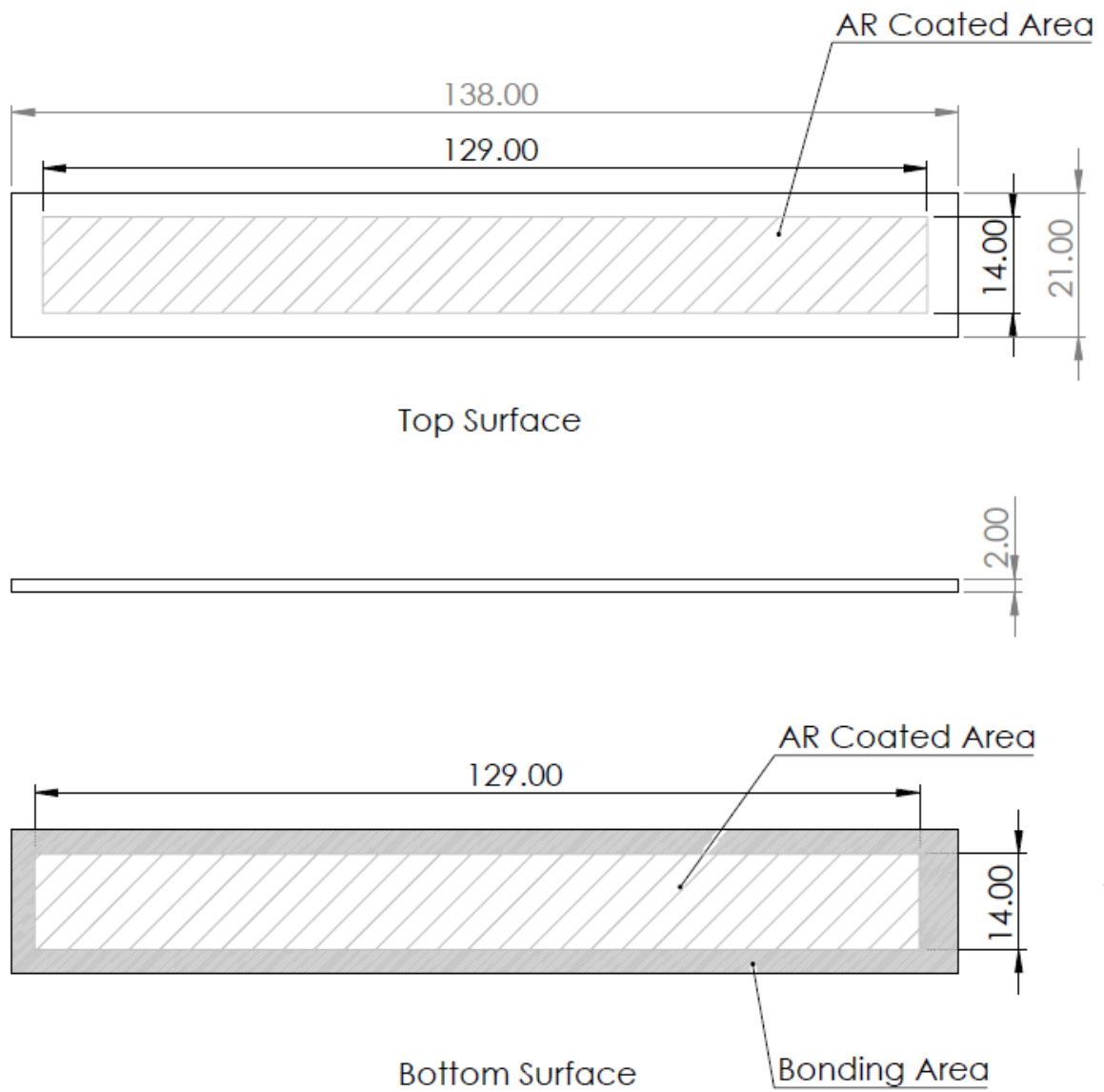

Figure 2: Schematic of the optical window for Imager-3

Table 1: Specifications of Optical Window

Sr. No.	Parameters	Optical window for Imager-2	Optical window for Imager-3
1.	Material	Fuse silica	Fuse silica
2.	Surface profile	Flat	Flat
3.	Shape	Rectangular	Rectangular
Substrate dimensions			
4.	Length (mm)	56.5 ± 0.1	138 ± 0.1
	Breadth (mm)	33.5 ± 0.1	21 ± 0.1
	Thickness (mm) (prior to coating)	2.0 ± 0.1	2.0 ± 0.1
Clear Aperture Dimensions (AR coated area)			
5.	Length (mm)	48.5 ± 0.1	129 ± 0.1
	Breadth (mm)	25.5 ± 0.1	14 ± 0.1
6.	Surface Figure (each surface) (Prior to coating)	Better than 315 nm (PV) Better than 78 nm (RMS)	Better than 315 nm (PV) Better than 78 nm (RMS)
7.	Surface Quality (Before and after coating)	40/20	40/20
8.	Surface Roughness (Before coating)	$< 30 \text{ \AA}$ Arms (in ARC coated area)	$< 30 \text{ \AA}$ Arms (in ARC coated area)
9.	Parallelism between the two polished surfaces (Before coating)	< 1 arc minute	< 1 arc minute
10.	Glass homogeneity	Schott NH2/ Equivalent grade or better	Schott NH2/ Equivalent grade or better
Specifications related to AR coating			
11.	Spectral range	400 - 1100 nm	400 - 1100 nm
12.	AR-coating reflectance per surface	$R_{\max} \leq 2 \%$	$R_{\max} \leq 2 \%$
		$R_{\text{ave}} \leq 1 \%$	$R_{\text{ave}} \leq 1 \%$
13.	Tavg	$> 95\%$	$> 95\%$
14.	Variation in the Tavg	$\leq \pm 2 \%$	$\leq \pm 2 \%$

Note:

- 1) Specification no. 6 and 7 are applicable to both the surfaces of window.
- 2) Specifications compliance parameters should be demonstrated in clean room environment at a temperature of $22 \pm 1^\circ\text{C}$.
- 3) Specification no. 11 to 14 should be demonstrated by carrying out spectral measurements at minimum 5 locations equally distributed along the length and width of the window.

1.2. Qualification Test Requirements

Vendor shall carry out qualification tests on three QM optical windows (QM1, QM2 and QM3) for coating qualification (for each batch) as per Table 2 and Table 3 and deliver these windows to SCL.

Table 2: Text Matrix of qualification samples

QM1	QM2	QM3
VI,SR	VI,SR	VI,SR
Cold Storage	Thermal Shock	Reference Sample
VI	VI,SR	
Hot Storage	-	
VI,SR	-	

VI-Visual Inspection, SR- Spectral Response

Table 3: Environmental test levels

Tests	Test Levels
Cold Storage	Temp: $-55^{\circ} \pm 1^{\circ} \text{C}$; Duration: 24 hrs.
Hot Storage	Temp: $125^{\circ} \pm 1^{\circ} \text{C}$; Duration: 24 hrs.
Thermal Shock	Temp: -55° to $+125^{\circ} \pm 1^{\circ} \text{C}$; Dwell time: 5 min No. of Cycles : 100

2. Test Results

- The supplier should supply the details of the measurement set-ups as well as the measurement conditions. All test results shall be provided in tabular form as per the Table-1 above.
- In addition, transmittance of bare polished substrate material shall be provided in the specified spectral regions.

3. Acceptance/ Rejection Criteria

The acceptance of final products is based upon their compliance with all the specifications / requirements laid down in the earlier sections of this document, the rejection criteria being deviations from the specifications. The batch wise windows will be accepted only if their qualification samples successfully qualify & meet all optical specifications. After environmental tests, there shall be no evidence of any coating degradation such as cracking, flaking, blistering or peel-off when viewed under bright light conditions (as per MIL- C- 675)

4. Packaging

All deliverables are to be packed with adequate protection preferably in dry nitrogen purged container to prevent damage of the components from humidity, dust and shock etc. The optical windows shall be clearly identified by the part numbers for easy identification.

5. Cleaning/ Handling/ Storage

The supplier shall specify the handling and storage conditions. Procedures to be adopted for cleaning the components also shall be specified.

