

Construction of service roads, improvement of junction and curves between km 585.600 to 593.340 km along Canacona bypass section of NH-66 in the State of Goa on EPC Mode.

**Public Works Department (NH), Goa  
Government of Goa**

**(Ministry of Road Transport & Highways)  
Government of India**

**Technical Schedules  
For**

**Construction of service roads, improvement of junction  
and curves between km 585.600 to 593.340 km along  
Canacona bypass section of NH-66 in the State of Goa on  
EPC Mode.**

**April, 2026**

## Schedule-A

(See Clauses 2.1 and 8.1)

### Site of the Project

#### 1 The Site

- 1.1 The site of four lane divided carriageway Project Highway shall include land, buildings, structures and road works as described in Annex-I of this Schedule-A.
- 1.2 The dates of handing over the Right of Way to the Contractor are specified in Annex-II of this Schedule-A.
- 1.3 An inventory of the Site including the land, buildings, structures, road works, trees and any other immovable property on, or attached to, the Site shall be prepared jointly by the Authority Representative and the Contractor, and such inventory shall form part of the memorandum referred to in Clause 10.3.1 of this Agreement.
- 1.4 The alignment plans of the Project Highway are specified in Annexure-III of Schedule-A. The proposed profile of the Project Highways shall be followed by the contractor with minimum FRL as indicated in the plan and profiles. The Contractor, however, improve/upgrade the Road Profile as indicated in Annex-III based on site/design requirement in consultation with the authority.
- 1.5 The status of the environment clearances obtained or awaited is given in Annex-IV.

## Annex - I

### (Schedule-A)

#### Site for Project

### 1 Site

1.1 The Site of the Project Highway comprises the section of NH-66 commencing from Km 585.600 to km 593.340 i.e, near Char-Rasta on Canacona bypass section on NH-66 and Electricity Department Sub Station to Mashem junction on Canacona bypass on NH-66 in the State of Goa. The land, carriageway and structures comprising the site are described below.

#### 1.2. Referencing System

Kilometre stones are existing in entire length of the project highway. It is called the “Existing Chainage”. During topography survey with Total Station, observations made are referred “Existing Chainage”. The relationship between the “Existing Chainage” and the “Design Chainage” as per field surveys of the location of existing km stones using the Total Station for the “**Project Highway**” is given at **Appendix A-I**. The existing length of and design length of project is 7.74km.

Category of Road	Design Chainage (Km)	Easting	Northing
NH	585.600	15.015587	74.035654
	593.340	14.956758	74.056037

#-UTM co-ordinates based on WGS 84 datum and 43N zone

An index map showing the existing features of the Project Highway is given at Annex-III of Schedule-A. The design chainage co-ordinates (centre line) at every 500m distance are given at Annex-VI of Schedule-A.

### 2 Land

The Site of the Project Highway is 4 lane, comprises the land (sum total land already in possession and land to be possessed) as described below.

Sl. No.	Existing Chainage (km)		Right of Way (m)	Remarks
	From	To		
1	585.600	593.340	45.00	-

*Detailed break-up of land is given as Annexure-II of Schedule-A.*

### 3 Carriageway

The details of existing carriageway are as given under.

Construction of service roads, improvement of junction and curves between km 585.600 to 593.340 km along Canacona bypass section of NH-66 in the State of Goa on EPC Mode.

Sl. No.	Chainage (Km)		Length (Km)	Lane Configuration (Two Lane / Four Lane)	Carriageway (m)
	From	To			
1	585.600	593.340	7.740	4 lane + Paved shoulder	2 x 8.75 m

#### 4 Major Bridges

The Site includes the following Major Bridges.

Sr. No.	Existing Chainage (Km)	Type of Structure			No. of Spans with Span length (m)	Width (m)
		Foundation	Sub Structure	Super Structure		
1	589.050 to 589.550	Pile	RCC	Steel Girder	10x40+1x50	23.00
2	592.000 to 593.200	Pile	RCC	Composite Steel Girder	15x30+1X50+1X33+15x30+3x33	23.00

#### 5 Road over-bridges (ROB)/ Road under-bridges (RUB)

The Site includes the following ROB (road over railway line)/RUB (road under railway line).

S. No.	Existing Chainage (km)	Span Arrangement (Nox Span length(m))	Super Structure	Deck Width (m)	ROB/ RUB
-Nil-					

#### 6 Grade separators

The Site includes the following grade separators.

Sr. No.	Existing Chainage (Km)	Type of Structure		No. of Spans with Span length (m)	Width (m)
		Foundation	Super Structure		
-Nil-					

#### 7 Minor bridges

The Site includes the following minor bridges.

S. No.	Existing Chainage (km)	Span Arrangement (No. x Span length in m)	Super Structure	Deck Width (m)
-Nil-				

Construction of service roads, improvement of junction and curves between km 585.600 to 593.340 km along Canacona bypass section of NH-66 in the State of Goa on EPC Mode.

## 8 Railway Level Crossings

The site includes the following Railway level crossings:

S. No	Design Chainage (Km)	Railway Line
-Nil-		

## 9 Vehicular Underpass

The Site includes the following vehicular underpasses.

S. No.	Existing Chainage (km)	Type of Structure	No. of Spans with span length (m)	Deck width (m)
1	586.150	Box type	1 X 15	23
2	587.700	Box type	1 X 15	23
3	588.100	Box type	1 X 15	23

## 10 Culverts

The Site has the following culverts.

### 10.1 Hume Pipe Culverts

Sl. No.	Chainage (km)	Dia of Opening (m)
1	587.400	1.20
2	587.700	1.20
3	591.400	1.20
4	591.450	1.20
5	591.500	1.20
6	591.550	1.20
7	591.600	1.20

### 10.2 Slab Culverts

Sl. No.	Chainage (km)	Span /Opening with span length (m)
Nil		

### 10.3 Box Culverts

Construction of service roads, improvement of junction and curves between km 585.600 to 593.340 km along Canacona bypass section of NH-66 in the State of Goa on EPC Mode.

Sl. No.	Existing Chainage (km)	Span /Opening with span length (m)
1	587.650	4m

#### 11 Bus bays

The details of bus bays are as follows:

S. No.	Existing Chainage (km)	Length (m)	Left Hand Side	Right Hand Side
1	587.800	90m		RHS

#### 12 Truck lay byes

The details of the truck lay byes are as follows:

Sr. No.	Chainage (Km)	Length (m)	Left Hand Side	Right Hand side
-Nil-				

#### 13 Road side drains

The details of the roadside drains are as follows:

Sr. No.	Existing Chainage (Km)		Side	Type	
	From	To		Masonry/CC (Pucca)	Earthen (Kutchra)
1	589.566	590.311	LHS	CC	-
2	589.550	590.311	RHS	CC	-

#### 14 Major junctions

The details of Major Junctions/Road Crossings are as follows:

S. No	Existing Location (Km)	Type of Intersection	Leads to		Category of Cross Road	Remarks
			Left	Right		
Nil						

(NH: National Highway, SH: State Highway, MDR: Major District Road)

#### 15 Minor junctions

Construction of service roads, improvement of junction and curves between km 585.600 to 593.340 km along Canacona bypass section of NH-66 in the State of Goa on EPC Mode.

The details of the minor junctions are as follows:

Sr. No.	Existing Chainage (Km)	Type of Intersection	Location	Side
1	586.550	Y	Bhagatwada	RHS
2	591.500	Y	Kolsar	RHS

## 16 Bypasses

The details of the existing road sections proposed to be bypassed are as follows:

S. No.	Name of bypass (town)	Chainage (km) From km to km	Length (in Km)
Nil			

## 17 Toll Plaza

The details of Toll Plaza are as follows:

Sl. No	Existing Chainage (Km)	Location	Side	Remarks
Nil				

## 18 Cattle / Pedestrian Underpass

The Site includes the following cattle / pedestrian underpasses.

S. No.	Existing Chainage (km)	Type of Structure	No. of Spans with span length (m)	Deck Width (m)
Nil				

## 19 Bus shelters

S. No	Existing Chainage (km)	Side	Location
1	587.800	BHS	

## 20 Wayside Amenities

The details of wayside amenities are as follows:

Sl. No	Existing Chainage (Km)	Location	Side	Remarks
Nil				

## 21 Utilities

Construction of service roads, improvement of junction and curves between km 585.600 to 593.340 km along Canacona bypass section of NH-66 in the State of Goa on EPC Mode.

The site includes utilities. Details at Annexure-V of Schedule-A.

**Design Chainage corresponding to Existing Chainage**

<b>Sl. No.</b>	<b>Category of road</b>	<b>Existing Chainage (Km)</b>	<b>Design Chainage (Km)</b>
1	NH-66	587.800	587.950
2	NH-66	591.400	591.600

Construction of service roads, improvement of junction and curves between km 585.600 to 593.340 km along Canacona bypass section of NH-66 in the State of Goa on EPC Mode.

**Annex - II**

**(Schedule-A)**

**Dates for providing Right of Way of Construction Zone**

The dates on which the Authority shall provide Right of Way of Construction Zone to the Contractor on different stretches of the Site are stated below:

Design Chainage (Km)		Length (km)	Existing ROW (m)	PROW (m)	Date of Providing ROW
From	To				
585.600	593.340	7.740	40-45	-	On Appointed Date

Construction of service roads, improvement of junction and curves between km 585.600 to 593.340 km along Canacona bypass section of NH-66 in the State of Goa on EPC Mode.

**Annex - III**

*(Schedule-A)*

**Alignment Plans**

The alignment of the Project Highway is enclosed. Contractor shall follow the existing road level as minimum FRL. However, the contractor shall improve/upgrade the Road profile based on site/design requirement in consultation with the Authority.

**Coordinates:-**

Category of Road	Design Chainage (Km)	Easting	Northing
NH-66	585.600	15.015587	74.035654
	593.340	14.956758	74.056037



Construction of service roads, improvement of junction and curves between km 585.600 to 593.340 km along Canacona bypass section of NH-66 in the State of Goa on EPC Mode.

## **Annex - IV**

*(Schedule-A)*

### **Environment Clearances**

**1. Forest Clearance:** Not required

**2. Environmental Clearance:** The MoEF clearance is not required as per Notification of MoEF dated 22/08/2013 for this project highway.

Annex - V

(Schedule-A)

The site includes the following electrical utilities:-

(i) Electrical Utilities \*

Extra High-Tension Lines (EHT Lines) \*

S. No	Chainage (Km)		Length (in km)				Crossings			
	From	to	400KV	220KV	110KV	66KV	400KV	220KV	110KV	66KV
Nil										

High Tension/ Low Tension Lines (HT/LT Lines) \*

Chainage (Km)	Section	Along the road length (In km)			Road Crossings (in Nos.)			DTC	
		33 kV (U/G)	11 kV (U/G)	L.T.	33 kV (U/G)	11 kV (U/G)	L.T.	kVA	Nos.
Km 587.800 to 587.950	NH-66	-	-	0.150	-	-	1	-	-
Km 591.400 to 591.600	Service road	-	-	0.400	-	-	-	-	-

**Note:** - Above length/numbers/scope of the existing LT/HT line shifting with pole and others electrical structures is indicative and minimum specified. The actual length/numbers/scope of the existing LT/HT line shifting with pole and others electrical structures shall be determined by the Contractor as per existing site conditions. Any increase in the length/numbers/scope specified in this Clause of Schedule A shall not constitute a Change of Scope.

(ii) Public Health Utilities (Water/ Sewage Pipe Lines) \*

The site includes the following Public Health Utilities:-

Sr. No	Type of Utility	Unit	Quantity	Chainage	Location
	Water pipeline				
-Nil-					

**Note:** - Above length/numbers/scope of the existing pipe line and other items are indicative and minimum specified. The actual length/numbers/scope of the pipelines

**Construction of service roads, improvement of junction and curves between km 585.600 to 593.340 km along Canacona bypass section of NH-66 in the State of Goa on EPC Mode.**

for shifting shall be determined by the Contractor as per existing site conditions. Any increase in the length/numbers/scope specified in this Clause of Schedule A shall not constitute a Change of Scope.

Construction of service roads, improvement of junction and curves between km 585.600 to 593.340 km along Canacona bypass section of NH-66 in the State of Goa on EPC Mode.

**Annexure VI**

**Schedule - A**

**Centreline Coordinates**

The Co-ordinates of centreline are given below:-

**Centre Line co-ordinates at start & end.**

<b>S. No.</b>	<b>Category of road</b>	<b>Chainage (Km.)</b>	<b>Easting</b>	<b>Northing</b>
1	NH-66	585.600	15.015605	74.035602
2		593.340	14.956622	74.056034

Northing and Easting in UTM co-ordinates are based on WGS84 as datum and Zone 43N.

Construction of service roads, improvement of junction and curves between km 585.600 to 593.340 km along Canacona bypass section of NH-66 in the State of Goa on EPC Mode.

## **Schedule - B**

*(See Clause 2.1)*

### **Development of the Project Highway**

#### **1 Development of the Project Highway**

Development of the Project Highway shall include design and construction of the Project Highway as described in this Schedule-B and in Schedule-C. The alignment plans of the Project Highway are specified in Annex-III of Schedule A. The proposed profile of the Project Highway shall be followed by the contractor with minimum FRL as indicated in the Plan and profiles. The contractor however, improve/upgrade the Road Profile as indicated in Annex-III based on site/design requirement.

#### **2 Rehabilitation and augmentation**

Rehabilitation and augmentation shall include provision of Minor bridge on cross road and widening of existing Minor bridges to roadway width of service road as described in Annex-I of this Schedule-B and in Schedule-C.

#### **3 Specifications and Standards**

The Project Highway shall be designed and constructed in conformity with the Specifications and Standards specified in Annex-I of Schedule-D.

## Annex - I

### (Schedule-B)

#### 1 Development of the Project Highway

The Project Highway shall generally follow the horizontal alignment shown in the plan specified in Annex-III of Schedule-A, unless otherwise specified by the Authority. Notwithstanding anything to the contrary contained in this Agreement or IRC:SP:84, the proposed plan & profile, locations of different structures/drains, chainages of different structures/drains, length of different structures/drains etc. of the project highway as indicated in the Schedule A, Schedule B, Schedule C and their Annexures shall be treated as minimum requirement. Based on site/design requirement, the Contractor shall finalize their Detailed designs (Development stage) including plan & profile of the project highway and submit the same to Authority & its Engineer for consent/ approval and safety audit by safety auditor, before the start of the execution of project. The designs so approved shall not be in contradiction with the scope of project. For avoidance of doubt, the provisions mentioned in Schedule B & C cannot be changed, only design of the components is to be submitted for consent/approval.

Any changes in the finally accepted DPR in respect of the proposed provision in Schedule B and Schedule C shall not constitute a change of scope, save and except any variations arising out of a change of scope expressly undertaken in accordance with the provision of Article 16.

##### 1.1 Width of Carriageway

1.1.1 Width of Carriageway shall be as specified in the TCS enclosed

1.1.2 Except as otherwise provided in this Agreement, the width shall be adjusted to fit into appropriate plans and cross sections developed in accordance with TCS enclosed.

1.1.5 The entire cross-sectional elements shall be accommodated in the available/proposed ROW. If required, suitable retaining structures shall be provided to accommodate the highway cross section within the available/ proposed ROW. The details of such sections are mentioned in Schedule-B. In case of any other section not included in Schedule-B, where retaining structures are to be provided, shall not constitute a Change of Scope.

1.1.6 The Project Highway shall follow the existing alignment unless otherwise specified by the Authority and shown in the alignment plan specified in Annex-III of Schedule-A. The Contractor shall, however, improve/upgrade the road profile as indicated in Annex-III of Schedule A based on site/design requirement.

##### 1.2 Width of Median

The width of median including kerb shyness shall be 1.4 to 5.0 metre.

###### 1.2.1 Median Opening

1.2.1.1 Median Opening shall be provided at following locations:

S.No	Design Chainage	Opening (m)	Width including shyness (m)	Remarks
------	-----------------	-------------	-----------------------------	---------

Nil
-----

## 2 Geometric Design and General Features

### 2.1 General

Geometric design and general features of the Project Highway shall be in accordance with Section 2 of the Manual.

### 2.2 Design speed

The design speed shall be the as per clause no. 2.2 of Manual for Plain/rolling terrain.

### 2.3 Improvement of the existing road geometrics

2.3.1 The existing road geometrics shall be improved as per the codal provisions. In the sections, where improvement of the existing road geometrics to the prescribed standards is not possible, the existing road geometrics shall be improved to the extent possible within the given right of way and appropriate road signs, pavement markings and safety measures shall be provided.

2.3.2 The entire cross-sectional elements shall be accommodated in the available/proposed ROW. If required, suitable full height retaining structures shall be provided to accommodate the highway cross section within the available/ proposed ROW. The details of such sections are mentioned in Schedule-B. In case of any other section not included in Schedule-B, where retaining structures are to be provided, shall not constitute a Change of Scope.

2.3.3 **Realignments:** The existing road shall be improved to the standards as specified in the manual at the following locations.

S. No	Design Chainage (Km)		Length (km)	Location
	From	To		
1	587.800	587.950	0.15	Near LHS approach from Ponsulem, Tarri etc.

2.3.4 **Bypasses:** The existing road shall be bypassed to the standards as specified in the manual at the following locations.

S. No	Design Chainage (Km)		Length (km)	Location
	From	To		
-Nil-				

### 2.4 Right of Way

Details of the Right of Way along Project Highway are given in Annex II of Schedule-A.

Construction of the highway shall be made within the ROW available.

i) Road survey to be carried out using Electronic Total Station (ETS), including plotting of existing road alignment, trees, electric poles, and other road features of entire stretch. Cross-sections shall be taken at required intervals. Alignment plan to be prepared and submitted in two hard copies and one soft copy (C.D.). Boundary pillars of standard design shall be fixed as per IRC:25-1967.

ii) Fencing to be provided using welded steel wire fabric of size 75 mm × 50 mm (suggestive) to prevent cattle movement, avoid encroachment, and prevent unauthorized dumping of debris/waste at Km.586.150, 588.550 & 592.000 for approximately 1589 metres length.

Note: No additional land beyond proposed ROW as given in Annex II of Schedule A shall be permitted. Therefore, wherever required retaining wall of suitable heights shall be provided to confine free side slopes of highway embankment for main carriageway / service road etc. on either side to accommodate the typical cross sections as given in Schedule -B within the limit of proposed ROW without any additional cost to the Client.

## 2.5 Type of shoulders

2.5.1 The Design Specification of paved shoulders shall conform to the requirements specified in paragraph 5.10 of the manual.

2.5.2 Shoulders shall be constructed in accordance with the paragraph 2.6 of the Manual.

2.5.3 In built-up sections, footpaths/fully paved shoulders shall be provided in the following stretches:

Sl. No.	Stretch (from km to km)	Fully paved shoulders/ footpaths	Reference to cross section
1	Km. 586.150 to Km. 586.550	Footpath on RHS	Typical cross section
2	Km.586.030 to Km. 586.150	Footpath	Typical cross section

2.5.4 The earthen shoulder of 1.0m width on shoulder side shall be provided as per the TCS enclosed with top 150 mm on earthen shoulder with well graded naturals and morrum gravel crust stones or combination thereof, confirming to Clause 401 of MoRTH specification. (Clause No. 5.11 IRC: SP:84-2019).

2.5.5 Design and specifications of paved shoulders and granular material shall conform to the requirements specified in the relevant Manual.

## 2.6 Typical cross-section (TCS) of the Project Highway

S. No	Category of road	Design Chainage (Km)		Length (km)	TCS Description	TCS Type
		From	To			
4	NH-66	587.800	587.950	0.150	Realignment of Existing 4 lane carriageway	

Construction of service roads, improvement of junction and curves between km 585.600 to 593.340 km along Canacona bypass section of NH-66 in the State of Goa on EPC Mode.

S. No	Category of road	Design Chainage (Km)		Length (km)	TCS Description	TCS Type
		From	To			
<b>Total</b>				<b>0.150</b>		

For Typical cross section figures refer Annex-II of Schedule-B.

**Note:**

1. Any variations in the lengths specified in the above table shall not constitute a Change of Scope.
2. Lengths mentioned in the above list for cross section types concerned to structures are inclusive of structure length.
3. Retaining wall/ RE wall shall be provided for full height on all structures.
4. Toe/retaining wall to be provided where ROW is restricted and at water bodies along the proposed highway on the sections specified in Schedule-B.

S. No	Category of road	Design Chainage (Km)		Side	Total Length (km)	Height range (m)	Remarks
		From	To				
1	Service Road	586.150	586.550	BHS	0.900	2-2.5	-
2	Service Road	587.300	587.700	BHS	0.850	2-2.5	-
3	NH-66	587.800	587.950	LHS	0.150	4-6	RCC
4	Service Road	591.400	591.600	RHS	0.300	2-2.5	-

5. Chainages may be adjusted according to location of structures as per drawings.
6. Median width tapering shall be provided 1 in 50 as per manual. (Clause no 2.5.4. IRC: SP:84-2019)
7. Provide detailing of placement and specification of Railing, Fencing and electric poles, etc. (Clause No. 2.17 IRC: SP:84-2019)
8. Cross sections mentioned above is indicative and shall be decided as per project requirement, existing gas pipe lines and availability of ROW. No COS shall be admissible on this account.
9. Detailing of placement and specification of railing, boundary wall and electric pole etc. to be provided as per drawings.

**2.7 Service roads/Slip Roads**

**2.7.1 Service/slip Road:** The height of embankment of service road shall confirm to clause 4.2.1 of IRC:SP:84.

**2.7.2** The service roads shall be constructed at the locations and for the lengths indicated below:

S. No	Design Chainage (Km)		Length (km)		Paved Carriageway Width including shyness (m)	Total Length (km)	Remarks
	From	To	LHS	RHS			

1	586.150	586.550	-	0.500	7.5	0.500	-
2	587.300	587.700	0.400	-	7.5	0.525	-
3	588.200	588.400	0.100	0.100	7.5	0.200	-
4	591.400	591.600	-	0.400	7.5	0.400	-
5	591.800	591.600	-	0.250	7.5	0.250	-
<b>Total</b>			<b>0.500</b>	<b>1.250</b>		<b>1.750</b>	

### 2.7.3 Separator Between Main Carriageway and Service/Slip Road (clause No. 2.15.1 IRC:SP:84-2019)

A separator between main carriageway and service/slip road shall be provided to prevent the pedestrians, local vehicles and animals entering the highway.

Note:

- a. Above length of the service/slip roads is minimum specified. The actual length of the service/slip/connecting roads shall be determined by the Contractor in accordance with the approved plan & profile and design approved from the Authority/Authority Engineer. Any increase/decrease up to 5 percent length from the length specified in this Clause of Schedule-B shall not constitute a Change of Scope. Any additional length beyond 5% shall be dealt in Change of Scope.
- b. The Acceleration, deceleration lane, right turning storage lane, entry/exit lanes shall be constructed as given in above table and shall be deemed to be part of the scope and no Change of Scope shall be considered for the same. (Clause No. 2.12.2 IRC: SP:84).
- c. Retaining wall shall be provided as per actual site condition to accommodate the Typical cross section within available ROW & same shall be deemed to be included in the scope of work.

### 3. Intersections and Grade Separators

All at-grade intersections and grade separated intersections shall be as per Section 3 of the Manual (IRC: SP 84). Existing at-grade intersections shall be improved to the prescribed standards. For improvement of intersections and at grade junction standards and type plan MoRT&H and IRC: SP:41 shall be followed.

Improvement of junctions shall be matched with design crossfall of main carriageway and within the extent of land availability. Side roads connecting to the main road shall be properly tie in with existing side road with acceptable gradient as per Manual.

The service road pavement composition shall be continued on crossroads of the intersections for the length specified for at-grade and grade separated intersections.

Properly designed intersections shall be provided at the locations and of the types and features given in the tables below:

#### 3.1 At-grade intersections

a) Major Intersections

Sl. No.	Design Chainage (Km)	Junction Type	Leads to		Median opening	Category of Cross Road	Carriageway width of cross road (m)	Length of crossroad to be developed (m)	
			LHS	RHS				LHS	RHS
Nil									

b) Minor Intersections

Sl. No.	Design Chainage (Km)	Junction Type	Leads to		Median opening	Category of Cross Road	Carriageway width of cross road (m)	Length of crossroad to be developed (m)	
			LHS	RHS				LHS	RHS
1	586.150	T	-	RHS	No	Others	7.5	-	-
2	586.550	Y	LHS	-	No	Others	7.5	-	-
3	587.700	T	LHS	-	No	Others	7.5	-	-
4	591.500	Y	-	RHS	No	Others	7.5	-	-
5	586.150	As per TCS	BHS	-	No	Others	As per TCS	-	-

Note:

- 1) Type of Junction to be improved as per manual. (clause No. 3.2.5 IRC:SP:84-2019)
- 2) The Contractor shall take up 'Detailed Engineering study' to ascertain further details of all intersections and treatment of the intersections shall be designed in accordance with the latest guidelines mentioned out in section-3 of the manual. Auxiliary lanes including storage, acceleration, and deceleration lane along with physical islands to be provided as per the site conditions and ROW. The crossroad at the junctions which are having a level difference from the main carriageway, are to be improved at the level of main carriageway for the length of 30 metre and then to be merged with the crossroad at the gradient not more than 1:50. (Clause No. 3.2.2 IRC: SP:84-2019)
- 3) For minor / major layout for left-in / left out arrangement with physical islands with hazard marking. Where there is space constraint to provide physical islands, the effect of junction kept wide opened can be avoided by ghost island with marking. (Fig 3.7, IRC: SP:84-2019)
- 4) For U-turn, Self-Regulated U-Turn facility shall be created. (Fig 3.6 IRC:SP:84-2019)

3.2 Grade separated intersection with/without ramps

Sl. No.	Design Chainage (Km)	Junction type	Span arrangement	Remarks
-Nil-				

3.2.1 Raised Footpath shall be provided for minimum length of 310m as part of junction improvement.

Construction of service roads, improvement of junction and curves between km 585.600 to 593.340 km along Canacona bypass section of NH-66 in the State of Goa on EPC Mode.

3.2.2 Existing protection wall shall be dismantled and new protection wall shall be constructed as part of the junction improvement and site requirement.

**3.2.3 Transverse Bar Markings:** - The crossroad junctions as mentioned above shall be provided with Transverse Bar Markings by thermoplastic paint at the approach of junctions as per IRC: 99.

**3.2.4 Speed breakers/Table Top Crossings:** - The crossroad junctions as mentioned above shall be provided with speed breakers and Table top crossings at the approach of junctions as per IRC: 99.

**Note:** -

The list and length of above major, minor junctions, footpath and protection wall is indicative only and any additional junctions required in the Project Highway shall have to be constructed by the Contractor in consultation with the Authority. However, no change of scope on account of additional junction will be accepted.

It is clarified that any other deficient junctions with cross BT/CC road is identified during development period in addition to those mentioned above shall be improved as per standard set forth in Schedule 'D'. Any Increase in the junction specified in the clause of Schedule B shall not constitute a Change of Scope.

For crossroad drainage facility, new HP culverts on crossroads shall be constructed as per Manual.

Improvement of culverts/drain up to 70m on the cross/connecting roads on Major & Minor junctions shall be in the scope of the Contractor.

The crossroad at junctions shall be regraded to attain gradient as per MoRTH standards & Type Designs for Intersections on National Highways.

The Contractor shall take up 'Detailed Engineering study' to ascertain further details of all intersections and treatment of the intersections shall be designed in accordance with the latest guidelines mentioned out in section-3 of manual.

Junction improvement under grade separators shall be carried out as per manual with proper entry/exit to crossroads and slip/service roads, etc. Auxiliary lanes including storage, acceleration and deceleration lane along with physical islands to be provided.

#### **4. Road Embankment and Cut Section**

Construction of road embankment/cuttings shall conform to the Specifications and Standards given in section 4 of the manual. Notwithstanding anything to the contrary contained in this Agreement or Manual, the proposed profile of the project highway as indicated in the Annex-III of Schedule B shall be treated as minimum requirement.

Based on site/design requirement, the Contractor shall design the alignment plans and profiles of the project highway based on site/design requirement mentioned in Schedule B with approval from the Authority within the available Right of Way.

Use of Pond Ash and Design of Pond Ash embankment shall be specified (Clause No. 4.2.4 & 4.4.4.i (d) IRC: SP:84-2019)

## 5. Pavement Design

5.1 Pavement design shall be carried out in accordance with Section 5 of the Manual.

### 5.2 Type of pavement

The pavement shall be flexible type for entire length of project highway.

#### 5.2.1 Design requirements

(a) **Design Period and strategy:** Flexible pavement for new pavement or for widening and strengthening of the existing pavement shall be designed for a minimum design period of 20 years. Stage construction shall not be permitted.

(b) **Design Traffic:** Notwithstanding anything to the contrary contained in this Agreement or the Manual, the Contractor shall design the pavement for a design traffic of 50 MSA for main carriageway and 20 MSA for service / slip roads.

5.3 In order to meet the intended functional requirement of respective pavement layers on main carriageway, the minimum thickness of respective pavement layers for main carriageway and connecting crossroads/ service roads/ slip roads/ entry/exit locations, acceleration/ deceleration lane, right turning lanes shall, however, in no case be less than as given below:

#### 5.4 Reconstruction of stretches with new pavement (clause no. 5.9.4 IRC:SP:84-2019).

Reconstruction of the stretches is as per the TCS enclosed.

#### 5.5 Bituminous Mix for Overlay (clause no. 5.9.8 IRC:SP:84-2019)

Bituminous Overlay shall be provided as per TCS schedule.

## 6 Roadside Drainage

6.1 Drainage system including surface and subsurface drains for the Project Highway including crossroads shall be provided as per section 6 of the Manual. RCC Drain cum footpaths shall conform to the cross-sectional features and other details as given in Annexures to Schedule-B and shall be provided as under:

Details of RCC Drain cum Footpath (Clause No. 2.13 & 6.2.6 IRC SP 84-2019)

Sr. No.	Design Chainage (Km)		Length (km)		Width of Drain (m)	TCS Type	Total Length (Km)
	From	To	LHS	RHS			
1	586.150	586.550	-	0.450	1.50		0.450

Footpath tiles shall be provided over drain slab as per the TCS drawings

Details of Load bearing RCC Drain (Clause No. 2.13 & 6.2.6 IRC SP 84-2019)

Sr. No.	Design Chainage (Km)		Length (km)		Width of Drain (m)	TCS Type	Total Length (Km)
	From	To	LHS	RHS			

Sr. No.	Design Chainage (Km)		Length (km)		Width of Drain (m)	TCS Type	Total Length (Km)
	From	To	LHS	RHS			
	587.300	587.700	-	0.400	1.50		0.400
	587.800	587.950	0.200	-	1.50		0.200
	587.800	587.950	3x0.150	-	1.50		0.450
	588.200	588.500	-	0.300	1.50		0.300
	592.800	593.050	-	0.250	1.50		0.250

Design chainage given in the above table is including structure length. Drain should be designed for vehicle loading.

Notwithstanding to the above mentioned schedule, contractor shall provide Footpath cum drain as per the site requirement and as specified by the Authority. Any changes in length shall not be a change of scope.

**Note: -**

- i) No Change of Scope on account of change in above specified length shall be considered.
- ii) The invert level of Roadside drains shall be minimum 500 mm below GSB bottom level & additional weep holes of 100 mm dia @1m c/c spacing shall be provided at GSB level in inner wall of built-up drain.
- iii) Drain top level shall be kept such as to suit/match the surface drainage requirements as per proposed FRL in built-up sections.
- iv) The cross section of earthen drain in open country section shall have minimum bottom width of 0.5m with side slopes of 1:1. Invert level of earthen side drains shall be as per hydraulic requirement & minimum 1 mt. below adjoining ground level.
- v) Drain should connect to the nearest Cross Drainage Structures.
- vi) Longitudinal slope of the drain shall be as per Manual.

In all built up areas RCC covered drains with Footpath shall be provided. FRP heavy duty chambers fitted with pre-moulded frame shall be provided at appropriate spacing. Suitable crossing shall be provided at approaches to properties etc. invert levels of drains shall be decided on the basis of ground slopes of adjoining properties and open grounds. Pedestrian guard rails shall invariably be provided in all built-up sections as per the site requirement and directed by the Authority for separating pedestrian traffic from the NH traffic as per IRC-99 and IRC-103.

Above length of the lined drains shall be determined by the Contractor in accordance with the Manual requirements with approval from the Authority. Any increase in the length specified in this Clause of Schedule-B shall not constitute a Change of Scope, save and except any variations in the length arising out of a Change of Scope expressly undertaken in accordance with the provisions of Article 13.

**6.2 Unlined Drains cleaning require for existing drain**

Unlined Drains other than above mentioned locations shall be provided in the entire project length which gets terminated at all crossroad locations. In case the definite outfall is not available, a rainwater harvesting system shall be provided at the deepest location for dispersal of water.

### 6.3 Drainage where Embankment Height is more than 3m.

Chute drain shall be provided at suitable intervals on embankment slopes. The drainage arrangement shall include kerb, cement concrete drainage channel at the edge roadway, Cement Concrete Chutes, CC bedding, energy dissipation basin, etc. Mountable Kerb shall be provided beyond the post of MBCB to channelize storm water into chute. (Clause No. 6.8.2.4 of IRC: SP:84-2019)

### 6.4 Drainage for Structures

A suitable drainage arrangement for storm water from deck slab shall be provided. Falling of water on any surface of the structures, flow of underneath or remain standing or flowing over the road below the structure is not permitted in any circumstances. (Clause No. 6.8 IRC: SP:84-2019)

## 7 Design of Structures

### 7.1 General

Project Highway is proposed to be constructed to two lane configuration. As such, superstructures of all bridges, culverts and other structures shall be designed for edge movement of the vehicle considering stitching of new superstructure in future during widening to additional lanes. IRC Special vehicle loading is to be considered in the design of all bridges, culverts and structures.

All structures except wherever expansion joints have been provided, the pavement layers shall be continued over the structures so as to ensure smooth riding quality in project highway. These structures shall be designed considering the dead load of pavement layers.

All major structures shall be designed preferably with continuous structure to reduce the number of expansion joints on the MJB/ ROBs/ flyover/ Interchange etc.

7.1.1 Bridges, culverts and structures shall be designed for IRC class Special Vehicle (SV) loading as per recommendation of IRC: 6 and constructed in accordance with section-7 of the manual. All structures shall conform to the cross-sectional features and other details specified therein.

7.1.2 The overall width of the structures shall be given in Annex-I of Schedule-B (Clause No.7.3 IRC SP:84).

7.1.3 The Safety Barrier and Footpath on Bridges and RoB shall continue on approaches. The footpath shall be provided with paved surface & railing till the embankment height is more than 3m. (Clause No. 7.17 IRC: SP:84)

#### Details of Structures with footpaths

Sr. No.	Location (Km)	Skew Angle	Footpath Width (m)		Remarks
			Left	Right	

-Nil-

7.1.4 Bridges in the improvement proposal need to be of high level bridge.

7.1.5 All structures shall be designed to carry utility services on the outer side of RCC barrier/Railing as per site requirement.

7.1.6 Cross section of the new culverts and bridges at deck level for the Project Highway shall conform to the typical cross sections given in Section 2.10 of the Schedule-B.

7.1.7 In bypass/realignment locations if the structure in existing crossroads is replaced to new locations. No change of scope shall be allowed.

7.1.8 If any new structures are proposed at canal cum bund roads along the project highway in consultation with concerned irrigation department/IE. No change of scope shall be applicable.

7.1.9 Wherever liquefaction is observed, ground improvement shall be done by replacing suitable material and compacting the soil to increase the penetration resistance to satisfy the clause 8.4.4 (v) of IRC114.

7.1.10 Proposed levels at structure locations as shown in plan & profile are only for guidance and any changes in levels shall not constitute change of scope provided at any location of bridges and grade separated structures the FRL as in drawing shall not be lowered.

7.1.11 The structures falling within acceleration / deceleration lane /taper shall be constructed to the required width at the location. These changes shall not be treated as a change of scope.

7.1.12 An effective drainage system for bridge decks shall be provided as specified in the Manual.

7.1.13 Repairs and rehabilitation of all existing bridges shall include but not limited to general cleaning of bridge and area around bridge, restoration of slopes and protective works, removal and relaying of existing wearing coat, repair and replacement of drainage spouts, construction of new crash barriers in place of old railing, providing of new expansion joints and bearings in place of old ones wherever required and repair and rehabilitation of damaged concrete, if any, and providing floor protection with rigid and flexible apron and embankment slope protection if any etc. to the complete satisfaction and as per directions of Independent Engineer/Authority. All the repairs and rehabilitation works shall be carried out as per standards and manuals.

7.1.14 The structures proposed to be retained, the FRL of those structures shall be maintained as per existing structure, widening/New construction shall be done as per the designed Finished Road level provided in any circumstances soffit level of proposed new bridge shall not be less than soffit of the existing bridge.

## 7.2 Culverts

7.2.1 Overall width of all culverts shall be equal to the roadway width of the approaches. Barrel Length may change as per height of embankment and shall get approval from Independent Engineer, this will not be considered under change of scope. The overall width of culverts shall be including width of main carriageway and slip/service roads/Entry ramps/Exit Ramps/

Construction of service roads, improvement of junction and curves between km 585.600 to 593.340 km along Canacona bypass section of NH-66 in the State of Goa on EPC Mode.

Acceleration/Deceleration lanes, etc. All culverts shall also be continued in median and in gap between main carriageway and service road.

The locations, vents and type of Culverts are tentative and Changes in the locations, vents and type of Culverts, if any shall be finalized as per site conditions in consultation with Authority, which shall not constitute COS.

Changes in the location and number of culverts, if any shall be finalized as per site conditions in consultation with Authority which shall not be considered as Change of Scope.

The invert level of proposed Box type structure at cart track/Cross drainage locations shall not be lower than the existing ground level.

The Contractor required to use precast concrete elements/segments (box culverts and girders) complying with Ministry circular no. RW/NH-34049/01/2020-S&R (B) dated 08.04.2022.

Floor protection works shall be as specified in the relevant IRC Codes and Specifications.

#### 7.2.4 Widening of existing pipe culverts:

The existing pipe culverts at the following locations shall be retained and widened:

(Culverts to be constructed in accordance with the paragraph 7.3 of the manual)

Sl. No.	Design Chainage (Km)	Existing Culvert Type	Skew Angle	Span/Opening (m)	Widening		Culvert Crossing type (Balancing/stream, etc)
					LHS	RHS	
1	587.400	HPC	-	1.20	-	9.50	
2	587.700	HPC	-	1.20	-	9.50	
3	591.400	HPC	-	1.20	-	9.50	
4	591.450	HPC	-	1.20	-	9.50	
5	591.500	HPC	-	1.20	-	9.50	
6	591.550	HPC	-	1.20	-	9.50	
7	591.600	HPC	-	1.20	-	9.50	

#### 7.2.5 Widening of existing slab culverts to Box culverts:

The existing slab/box culverts at the following locations shall be re-constructed as new culverts:

(Culverts to be constructed in accordance with the paragraph 7.3 of the manual)

Sl. No.	Design Chainage (Km)	Existing Culvert Type	Skew Angle	Span/Opening (m)	New / Reconstruction		Culvert Crossing type (Balancing/stream, etc)
					LHS	RHS	
1	587.650	Box culvert	30-40	4.00	8.00	-	stream

Note: - It is clarified that as per site requirement if any new culverts are identified and required for drainage arrangement same shall be constructed during development as per standard set forth in Schedule 'D' & as per instruction of Independent Engineer.

Construction of service roads, improvement of junction and curves between km 585.600 to 593.340 km along Canacona bypass section of NH-66 in the State of Goa on EPC Mode.

As per clause 2.10.2 of IRC: SP:84, Wherever box culverts and bridges allow a vertical clearance of more than 2 m, these can be used in dry season for pedestrian and cattle crossing by providing necessary flooring.

### 7.2.6 Reconstruction of existing Arch Cum Slab Culverts:

The existing Arch/Slab culvert at the following locations shall be re-constructed as new culverts:

(Culverts to be constructed in accordance with the paragraph 7.3 of the manual)

Sl. No.	Design Chainage (Km)	Existing Culvert Type	Skew Angle	Span/Opening (m)	New / Reconstruction	Culvert Crossing type (Balancing/stream, etc)
-Nil-						

Note: - It is clarified that as per site requirement if any new culverts are identified and required for drainage arrangement same shall be constructed during development as per standard set forth in Schedule 'D' & as per instruction of Independent Engineer.

Culverts should also extend to service road/slip lane as per applicable in 2 (viii) if this schedule. Also, culverts shall be provided for full width as per applicable Typical Cross section.

The dimensions and numbers given above are minimum and the proposed dimensions shall be based on hydraulic calculations and approval from Independent Engineer. Any changes to above dimensions shall not be constitute a change of scope.

### 7.2.7 Widening of existing box culverts:

All existing culverts which are not to be reconstructed shall be widened to the roadway width of the Project Highway as per the typical cross section given in the provision of relevant Manual. Repairs and strengthening of existing structures where required shall be carried out.

Sr. No	Design Chainage (Km)	Skew Angle	Span/Opening (m)	Repairs / Rehabilitation proposals	Culvert Crossing Type (Balancing/ Stream, etc)	Remarks
-Nil-						

### 7.2.8 Additional new box culverts

Additional new Box culverts shall be constructed at the following locations in the realignment sections as per particulars given in the table below:

Sl No.	Culvert location	Span/Opening (m)
-Nil-		

Note:- The above mentioned culverts are minimum to be provided on the Project Highway, however, the Contractor shall provide additional culverts if required as per hydraulic calculations, no Change of Scope on this account will be considered.

Note:- Location of the new box culverts are tentative and to be finalised in consultation with Authority, any changes in the location shall not be considered as Change of Scope.

Construction of service roads, improvement of junction and curves between km 585.600 to 593.340 km along Canacona bypass section of NH-66 in the State of Goa on EPC Mode.

**7.2.9 Repairs/replacements of railing/parapets, flooring and protection works of the existing culverts shall be undertaken as follows:**

Sl. No.	Location at km	Type of repair required
-Nil-		

**7.2.11 Details of Additional New Culverts:**

Box culverts of minimum size 2m x 1.5m shall be provided on each side of crossroads to maintain the longitudinal continuity of drain water flow along the Project Highway as per section 6 of the Manual.

**7.3 Bridges**

**7.3.1 Existing bridges to be re- constructed:**

(i) The existing bridges at the following locations shall be re-constructed and widened as new Structures.

Sl. No	Design Chainage (km)	Existing span (m)	Total Proposed length (m)	Total proposed width (m)		Skew Angle	Remarks
				LHS	RHS		
-Nil-							

**7.3.2 The following Minor bridges shall be retained and widened:**

Sl. No.	Location (km)	Existing width (m)	Extent of widening (m)	Cross-section at deck level for widening
-Nil-				

**7.3.3 Additional new Major bridges**

New bridges at the following locations on the Project Highway shall be constructed. GADs for the new bridges are attached in the drawings folder.

Sl. No.	Design Chainage	Proposed Type	Existing Span arrangement
-Nil-			

**7.3.4 Additional new Minor bridges**

New bridges at the following locations on the cross road shall be constructed. GADs for the new bridges are attached in the drawings folder.

Sl.No.	Design Chainage	Proposed Type	Proposed Span arrangement
-Nil-			

**7.3.5 Retained Minor bridges**

Bridges at the following locations on the Project Highway shall be retained. Details for the retained bridges are attached in the drawings folder.

Construction of service roads, improvement of junction and curves between km 585.600 to 593.340 km along Canacona bypass section of NH-66 in the State of Goa on EPC Mode.

Sl. No	Existing Chainage(Km)	Proposed Type	Existing Span arrangement
-Nil-			

**7.3.6** The railings of existing bridges shall be replaced by crash barriers at the following locations:

Sl. No.	Location at km	Remarks
Nil		

**7.3.7** Repairs/replacements of railing/parapets of the existing bridges shall be undertaken as follows:

Sl. No.	Location at km	Remarks
Nil		

**7.3.8 Drainage system for bridge decks**

An effective drainage system for bridge decks shall be provided as specified in the 7.20 of the Manual

**7.3.9 Structures in marine environment**

All structures near to and within the vicinity of 15Km to sea coast is susceptible to chloride induced corrosion of reinforcement. As a precautionary measure, to meet with the service life of the bridge as per design. The reinforcement for all RCC works shall confirm to MoRTH circulars and guidelines in this regard.

Note:

- Width is excluding Median (M) gap and the gap between Main Carriageway (MCW) & Service/Slip Road (SR).
- Location and span are indicative. Exact location may be decided in consultation with PWD and the same shall not constitute a Change of Scope, save and except any variations arising out of a Change of Scope expressly undertaken in accordance with the provisions of Article 16.
- Span arrangement mentioned above is tentative and may be changed based on design of structure, latest construction techniques and aesthetics of structures. The span lengths mentioned are optimum required span and should not be reduced. The actual lengths as required on the basis of detailed investigations shall be determined by the Contractor in accordance with the Specifications and Standards. Any increase in the lengths specified in this Schedule-B shall not constitute a Change of Scope, save and except any variations in the length arising out of a Change of Scope expressly undertaken in accordance with the provisions of Article 13.
- In Case of bridges proposed for widening/repair as per details above, the same shall be re-constructed if the design shows that these are unsafe for design loads. No change of scope shall be considered in such cases.
- Expansion joints shall be minimized by deck continuity/ continuous superstructure over multiple spans. Deck length between two expansion joints shall not be less than 120m except where structure length falls short of it. Expansion joints shall be Finger joint type in compliance with IRC: SP:69-2011, Table 5.4.1 criteria for adoption of different types of

expansion joints. Contractor shall ensure quality control as per good industry practice and shall ensure presence of manufacturer of expansion joints at the time of installation for quality control supervision.

#### 7.4 Rail-road bridges

7.4.1 Design, construction and detailing of ROB/RUB shall be in accordance with Section 7 of the Manual.

#### 7.4.2 Road over-bridges

Road over-bridges (road over rail) shall be provided at the following level crossings, as per GAD drawings attached:

Sr. No.	Design Chainage (Km)	Proposed Span Arrangement (m)	Type of super-structure	Name of crossing	Total Width m)	Skew Angle	Remarks
-Nil-							

Note:

- i) The proposed span arrangements of the ROB's are tentative and subject to change as per availability of railway boundaries / requirements of the railways and as per the latest circular of Railway. Any change in the proposed span arrangement / variation in length shall not be treated as change in scope of work.
- ii) ROB shall be designed, constructed, and maintained as per the requirements of Railway authorities. The construction plan shall be prepared in consultation with the concerned railway authority.
- iii) The ROB shall be constructed and maintained by the Contractor under supervision of the Railways.
- iv) All charges payable to the Railways like D&G, Capitalized maintenance, signalling, cabling, OHE modification, earthing etc. except P&E charges shall be borne by the Contractor.
- v) The proposed span arrangements of the RUBs are tentative and subject to change as per availability of railway boundaries/requirement of the railways.

#### 7.5 Grade separated structures

The grade separated structures shall be provided at the locations and of the type and length specified in paragraphs 2 (ix) and 3 of this Annex-I.

#### 7.6 FoB/ Skywalks

FoB/Skywalks shall be provided in built up areas/ near schools.

Sr. No.	Location at km	FoB Type	Remarks
-Nil-			

1.1.i. A summary of Culverts, Bridges and Structures shall be presented as follows:

Construction of service roads, improvement of junction and curves between km 585.600 to 593.340 km along Canacona bypass section of NH-66 in the State of Goa on EPC Mode.

Sr. No.	Name of the Structure	Total Numbers	Remarks
1	Minor Bridge on cross road (New construction)	-	-
2	Minor Bridge(Retained)	-	-
3	Minor Bridge(Retained and Widening)	-	-
<b>Total</b>		-	-

## 8 Traffic Control Devices and Road Safety Works

8.1. Traffic control devices and road safety works shall be provided in accordance with Section 9 of the Manual.

### 8.2. Traffic Signs:

Traffic signs shall be provided as per IRC 67 as mentioned in Schedule-C.

### 8.3. Pavement Marking:

Pavement markings shall be completed as per IRC 35 as mentioned in Schedule-C.

### 8.4. Safety Barrier:

The safety barriers shall be provided in accordance with Section-9 of the Clause 9.7 of the manual. The Safety Barrier length proposed are excluding the safety barrier already proposed on Culverts, Grade Separated Structures, Interchange, Bridges, RoB and RUB as applicable cross sections respectively.

End Treatment of Steel barriers/Rope Barrier shall be specified i.e. MELT or P-4 confirming to EN 1317-4, TT, MBCB barrier to Concrete Barrier (Clause No. 9.7.2 (b) IRC: SP:84-2019)

End Treatment to Concrete barrier shall be done as specified in Clause No. 9.7.3 (b) IRC: SP:84-2019.

The details of the location are as below:

S. No	Item	LHS		RHS		Total Length (Km)	Remarks
		(From in Km.)	(To in Km.)	(From in Km.)	(To in Km.)		
1	Concrete Single faced barriers	-	-	-	-	-	-
		-	-	-	-	-	
		-	-	-	-	-	
<b>Total</b>						-	
2	Metal Beam Crash Barrier (Thrie-Beam)	590.600	591.800	591.155	591.255	1.300	
<b>Total</b>						<b>1.300</b>	
3	Metal Beam	-	-	-	-	-	

Construction of service roads, improvement of junction and curves between km 585.600 to 593.340 km along Canacona bypass section of NH-66 in the State of Goa on EPC Mode.

	Crash Barrier (Double faced Thrie-Beam)						
<b>Total</b>						-	

Above length of the crash barriers is indicative and minimum specified. The actual length shall be determined by the Contractor in accordance with the Manual requirements with approval from Authority. Any increase in the length shall not constitute a Change of Scope.

The crash barrier shall follow the Codal provisions of IRC:119.

## 9 Roadside Furniture

9.1 Roadside furniture shall be provided in accordance with the provisions of Section 11 of the Manual. It shall be provided as per the details mentioned in Schedule-C.

**Note:** All Traffic Signs for Road Users would be provided as per IRC-SP-84 Manual. However, the Contractor shall provide numbers of Cautionary, Mandatory, Warning and Informatory Traffic Sign Boards at hazardous locations considering pedestrian and vehicle safety. The locations shall be finalized in consultation with Independent Engineer.

## 10 Compulsory Afforestation

Trees are required to be planted by the contractor as compensatory afforestation and at the location as directed by the authority. The other requirement as stipulated in the environmental clearance condition shall be adhered to.

## 12 Special Requirement for Hill Roads Protection.

### Left Hand Side (RHS):

Retaining walls shall be constructed for the length and TCS as given in the table below:

S. No	Design Chainage (Km)	Minimum Height (m)	Proposed Length (m)	TCS TYPE
1.	532+300 TO 532+640	3.00	150.00	TCS
		<b>TOTAL=</b>	<b>150.00</b>	

Note: (i) The specifications of Retaining Wall shall be as per relevant manual.

(ii) The back side of retaining wall will be provided with nonwoven

geotextile of minimum thickness of 0.75mm.

- (ii) The minimum scope of Retaining wall is defined as above.  
Any increase in quantity within 10% of the scope defined shall not be considered as a Change of Scope.

**(b) Slope stabilization on Hill Side:**

Seeding shall be provided as per relevant manual/code:

**a. On Hill side**

S. No.	Stretch	Proposed Solution	TCS Type
1	532+300 TO 532+640 KM (Hill side only)	<p><b>Hill side:</b></p> <p>i. Excavation of slope at 1:2 or as suitable with benching of 2m-3m width and terracing along with berm drain with multiple steps for length of so as to provide suitable stabilization of the cut slopes.</p> <p>ii. Provision for surficial protection with seeding.</p>	TCS-1

**Note:** The approx. Minimum quantities of work are as follows;

1. Special slope protection work is defined for a minimum area of 3750 Sqm.
2. Excavation in soil & transportation- 25392cum.
3. Rubble packing- 263.25cum.
4. PCC-15-133.50cum.
5. Backfilling with granular material & filter media -1008Cum.
6. Non-Woven Geotextile-840Sqm.
7. Seeding -2700Sqm.

Any increase in quantity of items within 10% of the defined scope shall not be considered as a Change of Scope.

**12 Shifting of Utilities**

Shifting of obstructing existing utilities indicated in Schedule A to an appropriate location in accordance with the standards and specifications of concerned Utility Owning Department is part of the scope of work of the Contractor. The bidders may visit the site and assess the quantum of shifting

of utilities for the projects before submission of their bid. Copy of utility relocation plan is enclosed. The specifications of concerned Utility Owning Department shall be applicable and followed.

Notes:

- a. The type/spacing/size/specifications of poles/towers/line/cables to be used in shifting work are as per the guidelines of utility owning department and it is solely between Contractor and the Utility owning department. No change of scope shall be admissible and no cost shall be paid for using different type / spacing / size / specifications in shifted work in comparison to those in the existing work or for making any overhead crossings to underground as per requirement of utility owning department and / or construction of project highway.
- b. The Contractor shall carry out joint inspection with utility owning department and get the shifting scheme sanctioned from utility owning department.
- c. The assistance of the Authority is limited to forwarding letter on the proposal of Contractor to utility owning department whenever asked by the Contractor.
- d. The decision/approval of utility owning department shall be binding on the Contractor.
- e. Project road is city road and may have various unknown underground utilities. During work/excavation if any utility gets damaged by the Contractor knowingly or un-knowingly, Contractor have to re-construct the utility immediately at his own cost. If any new underground utilities are found during the execution at site, the Contractor shall shift the utilities and it does not constitute any change of scope.
- f. The supervision charges at the rates/charges applicable between the Authority and utility owning department as and when Contractor furnishing a demand of Utility Owning Department along with a copy of estimated cost given by the later shall be paid directly by the Authority to the Utility owning Department or the Contractor may pay these charges to the utility owning department if directed by Engineer in Charge & the same will be reimbursed to him by the Authority.
- g. The dismantled material/scrap of existing Utility to be shifted/ dismantled shall belong to the Contractor/Contractor who would be free to dispose-off the dismantled material as deemed fit by them unless the Contractor is required to deposit the dismantled material to utility owning department as per the norm & practice and in that case the amount of credit for dismantled material may be availed by the Contractor as per estimate agreed between them.
- h. The utilities shall be handed over after shifting work is completed to Utility Owning Department after due testing as desired by them & up to their entire satisfaction.
- i. The maintenance liability shall rest with the Utility Owning Department after handing over process is complete as far as utility shifting works are concerned.
- j. The above scope of electrical shifting involves all the necessary fixtures & fastenings as per site condition, specification & standard practice of utility owning entity
- k. The above quantities may vary depending upon actual alignment & site conditions, hence above quantities are subjected to negative CoS.

- l. The Contractor & Independent Engineer shall try to optimize the quantum of shifting. Actual length & location of shifting will be decided by Joint Inspection with Independent Engineer & Utility Owning Entity.
- m. The above scope of water shifting involves all necessary sluice valves. Air Valves, Connections, Lowering, fixing, jointing fixtures & fastenings as per guidelines & specifications of utility owning entity.
- n. Shifting of all existing, buried and overhead utility lines are to be shifted by the Contractor within the scope of the Contractor. No change of scope shall be accepted on account of any change in quantities / specifications of the utility lines to be shifted.

The Utilities shall be shifted to extreme edge of Row as per relevant TCS & as directed by Independent Engineer.

### **13 Change of Scope**

The length of Drain, Footpath Cum Drain, Crash barrier specified here in above shall be treated as an approximate assessment. The actual lengths as required on the basis of detailed investigations shall be determined by the Contractor in accordance with the Specifications and Standards. Any variations in the lengths specified in this Schedule-B shall not constitute a Change of Scope, save and except any variations in the length arising out of a Change of Scope expressly undertaken in accordance with the provisions of Article 13.

### **14 Work Zone Traffic Management Plans**

The traffic diversion plans shall be prepared as per IRC SP 55 for smooth flow of traffic and safety. A diversion plan shall be proposed for construction of Culvert, Grade Separated Structures, Bridges, RoB/RUB, etc. and traffic management plan for widening/ reconstruction of carriageway. (Clause No. 7.19 IRC: SP:84-2019)

Construction of service roads, improvement of junction and curves between km 585.600 to 593.340 km along Canacona bypass section of NH-66 in the State of Goa on EPC Mode.

Construction of service roads, improvement of junction and curves between km 585.600 to 593.340 km along Canacona bypass section of NH-66 in the State of Goa on EPC Mode.

**Annex-II**  
**(Schedule-B)**  
**Typical Cross sections:**

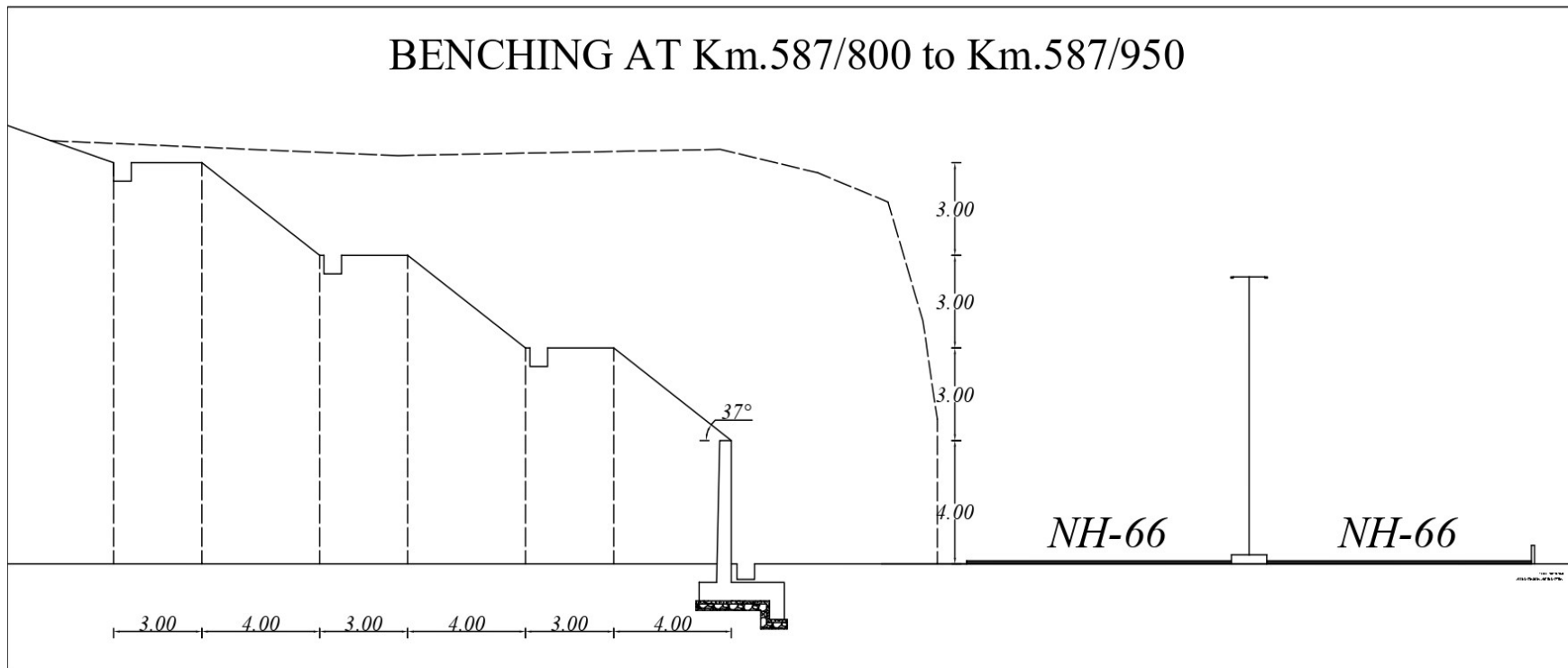



Construction of service roads, improvement of junction and curves between km 585.600 to 593.340 km along Canacona bypass section of NH-66 in the State of Goa on EPC Mode.

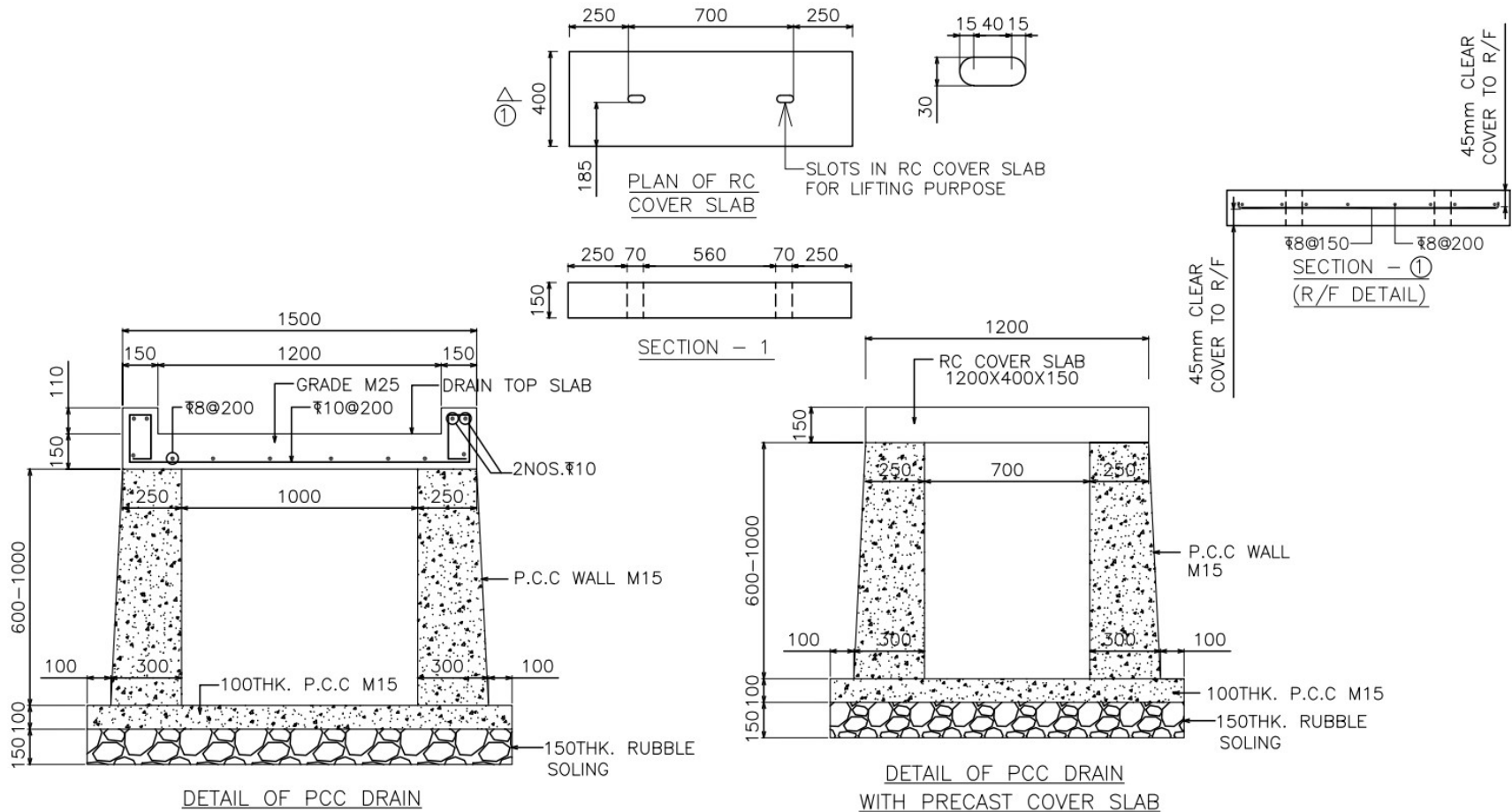

**NOTES:-**

1. ALL DIMENSIONS ARE IN MILLIMETERS AND LEVELS IN METERS.
2. NO DIMENSIONS SHALL BE SCALED FROM THIS DRAWING.
3. GRADE OF CONCRETE SHALL BE M25
4. CLEAR COVER TO THE OUTER MOST R/F SHALL BE 50mm UNLESS OTHERWISE SPECIFIED
5. † INDICATES TMT BARS CONFIRMING TO IS:1786-LATEST GRADE FE500
6. LAP LENGTH SHALL BE 50 TIMES DIA OF BAR

Construction of service roads, improvement of junction and curves between km 585.600 to 593.340 km along Canacona bypass section of NH-66 in the State of Goa on EPC Mode.

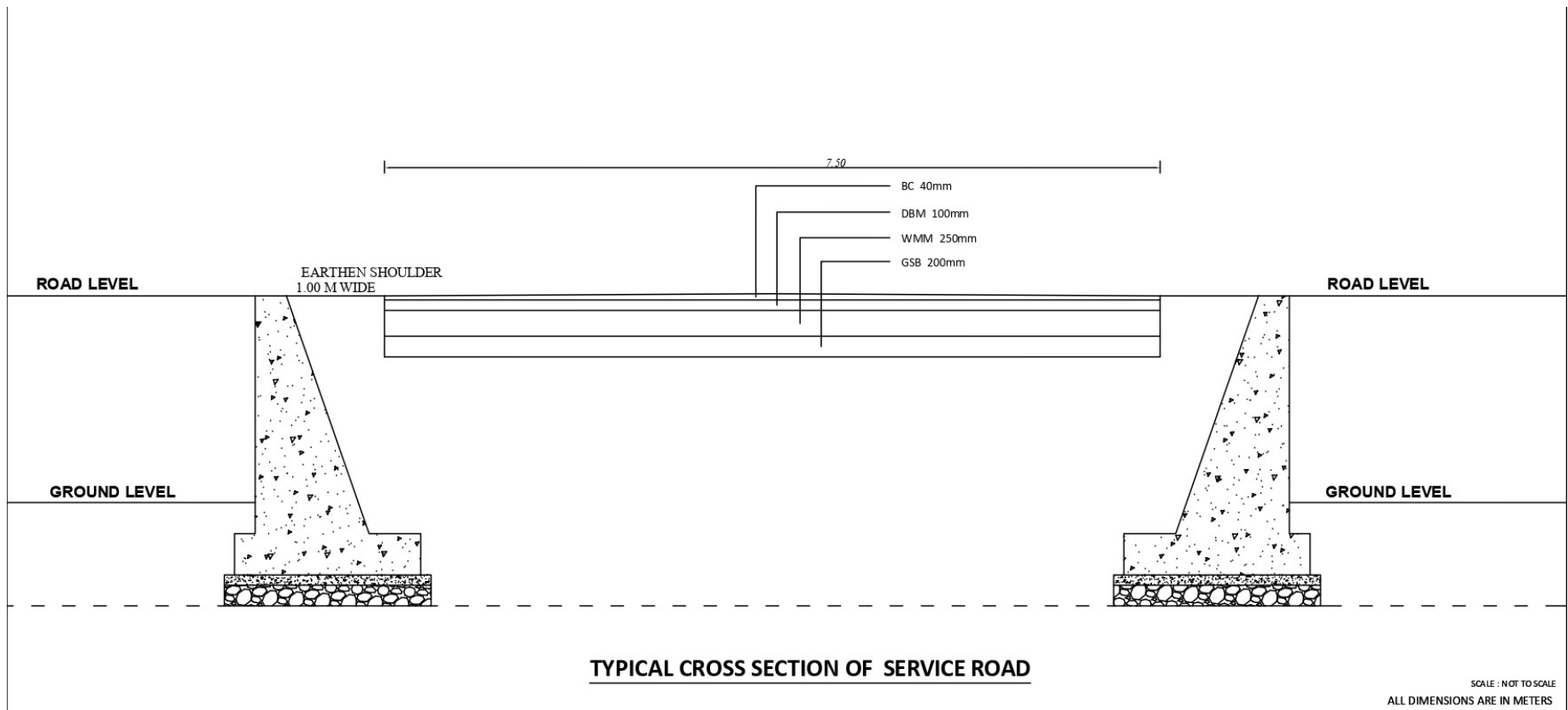

Construction of service roads, improvement of junction and curves between km 585.600 to 593.340 km along Canacona bypass section of NH-66 in the State of Goa on EPC Mode.

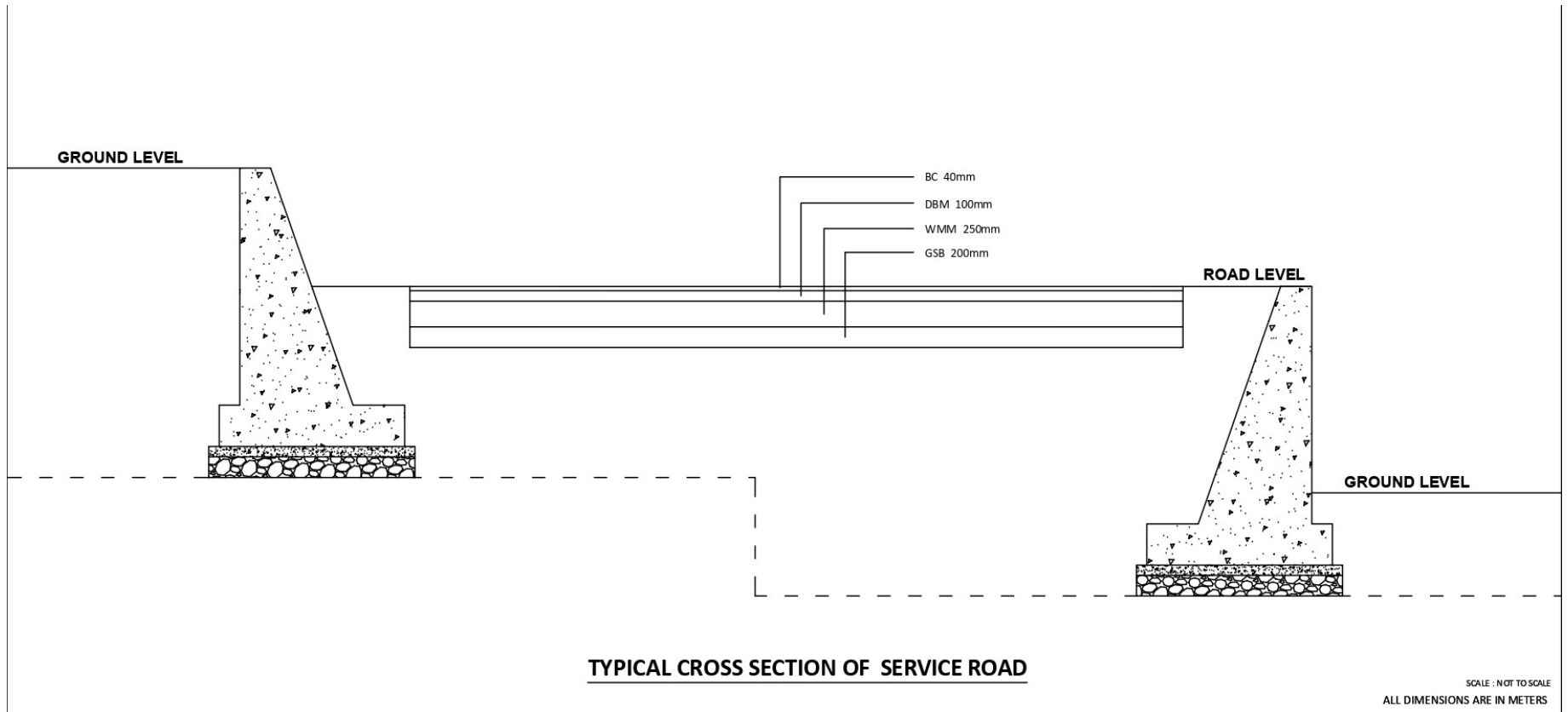

Construction of service roads, improvement of junction and curves between km 585.600 to 593.340 km along Canacona bypass section of NH-66 in the State of Goa on EPC Mode.

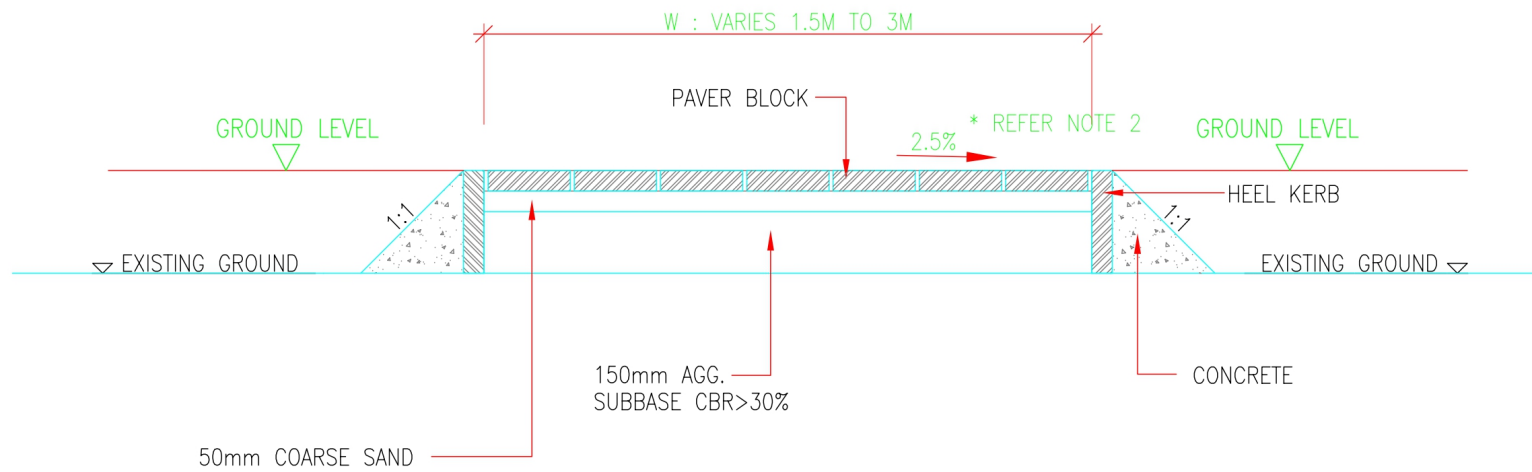

## FOOTPATH DETAILS

Construction of service roads, improvement of junction and curves between km 585.600 to 593.340 km along Canacona bypass section of NH-66 in the State of Goa on EPC Mode.

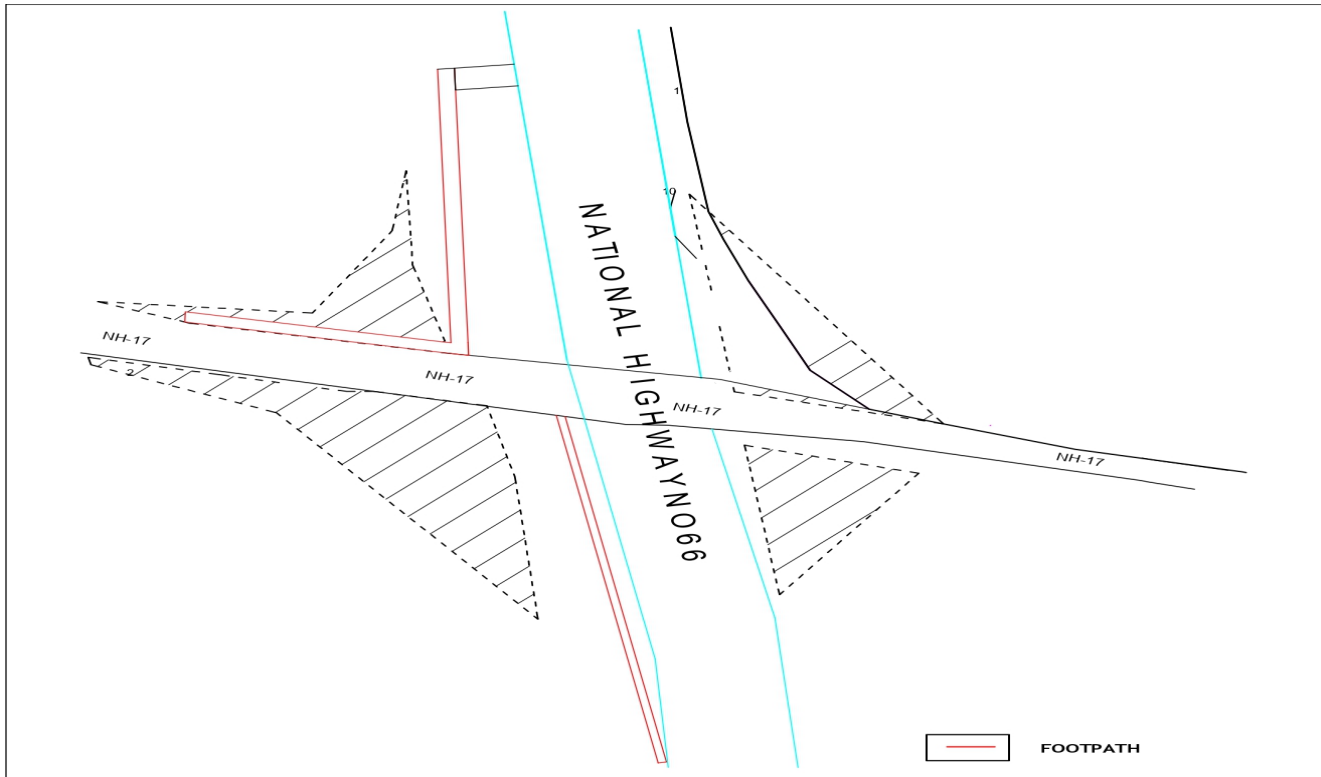

Location of Footpath

Construction of service roads, improvement of junction and curves between km 585.600 to 593.340 km along Canacona bypass section of NH-66 in the State of Goa on EPC Mode.

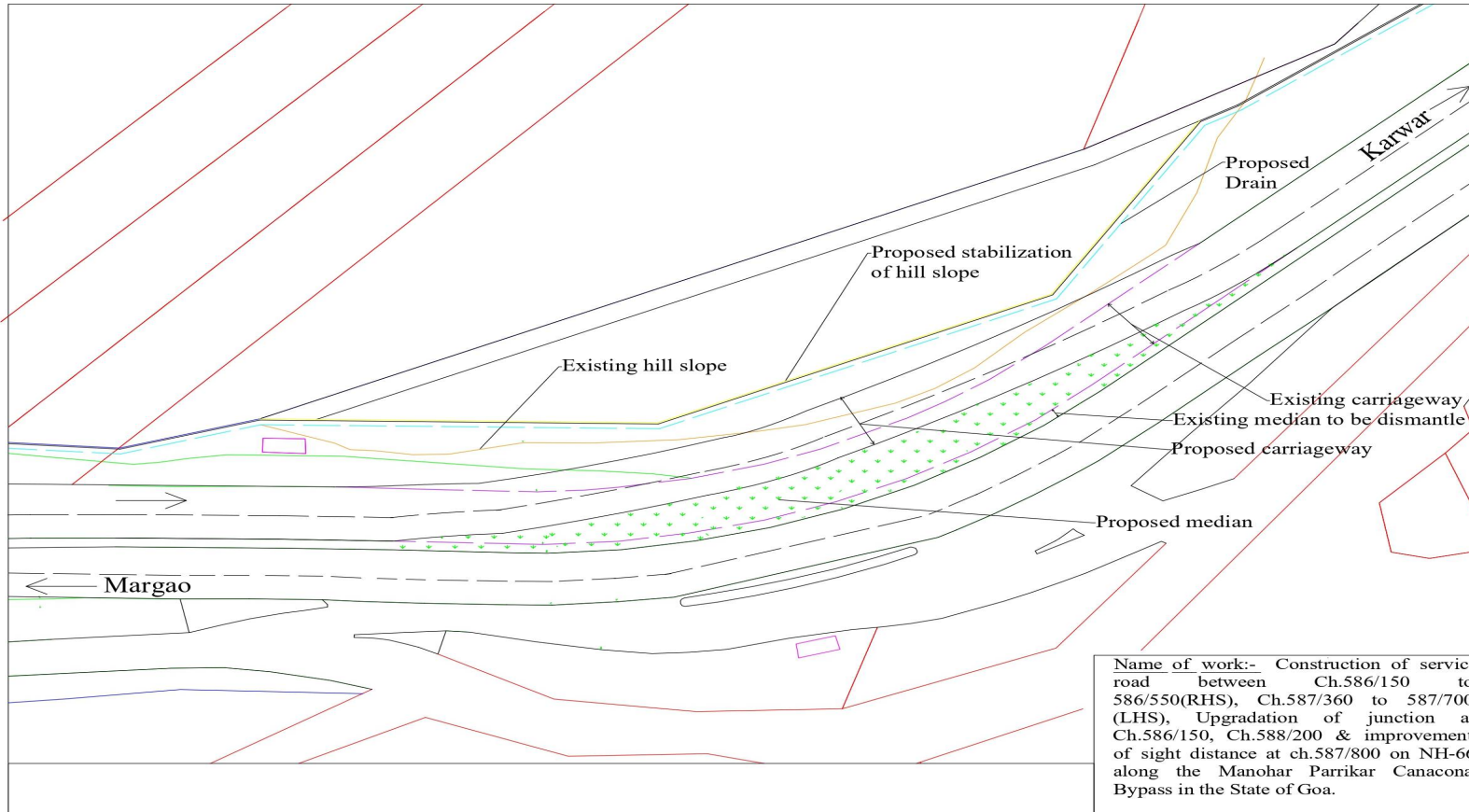

Improvement of curve at km.587.800 to km.587.900

Construction of service roads, improvement of junction and curves between km 585.600 to 593.340 km along Canacona bypass section of NH-66 in the State of Goa on EPC Mode.

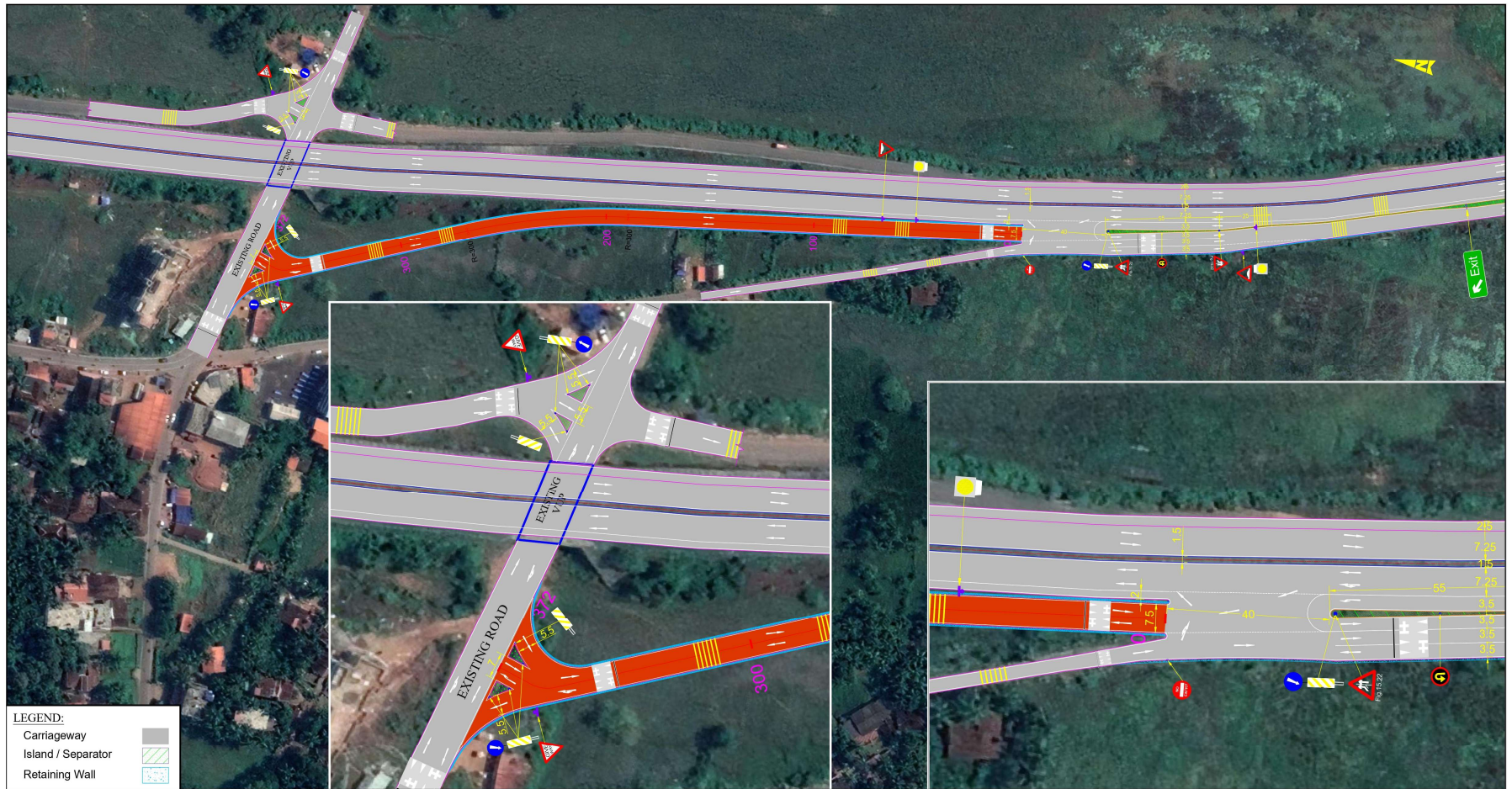

Junction Drawing - KM.586/150-KM.586/550

Construction of service roads, improvement of junction and curves between km 585.600 to 593.340 km along Canacona bypass section of NH-66 in the State of Goa on EPC Mode.

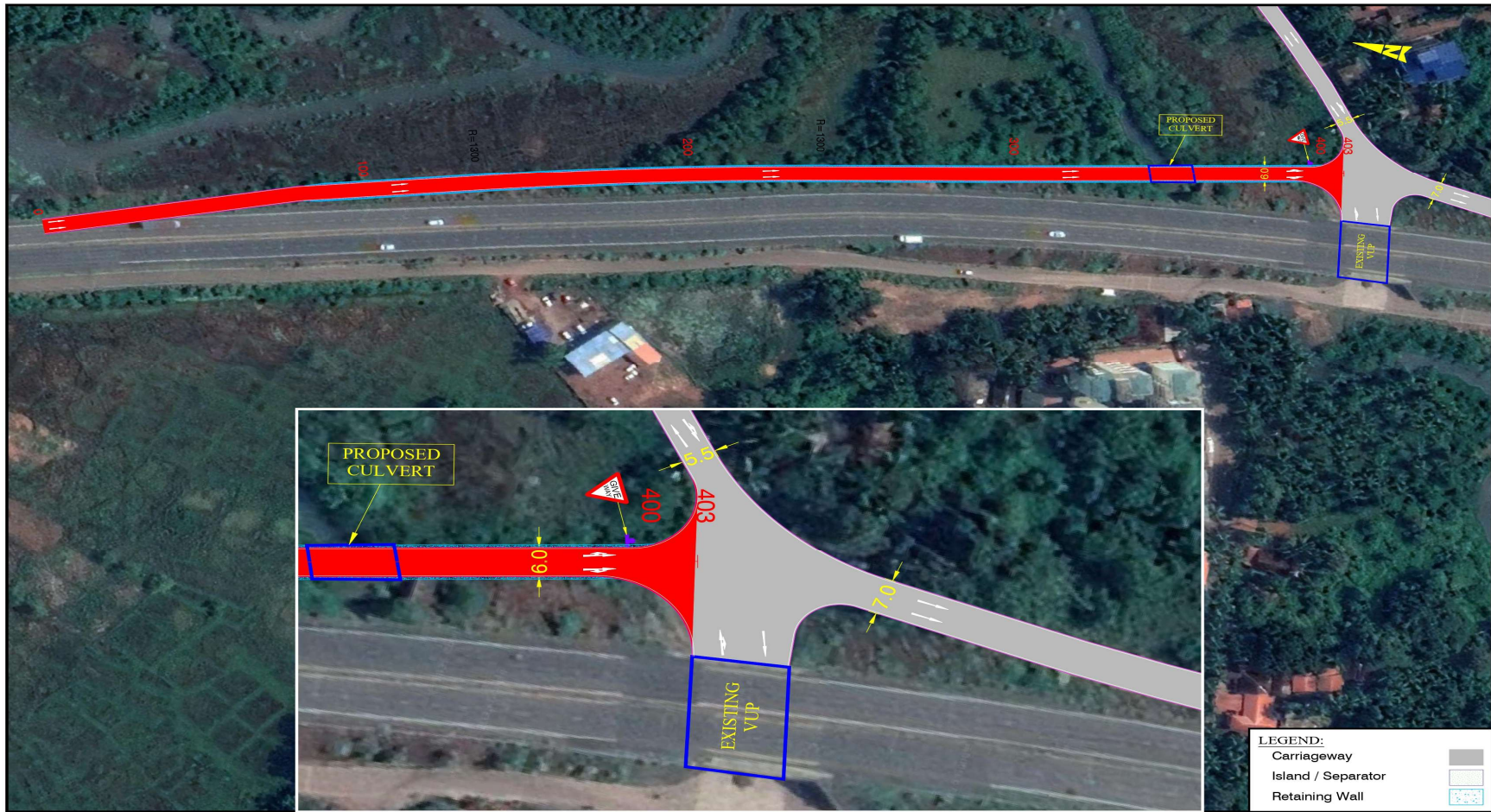

Junction Drawing - KM.587/700

Construction of service roads, improvement of junction and curves between km 585.600 to 593.340 km along Canacona bypass section of NH-66 in the State of Goa on EPC Mode.



Junction Drawing - KM.591/500

Construction of service roads, improvement of junction and curves between km 585.600 to 593.340 km along Canacona bypass section of NH-66 in the State of Goa on EPC Mode.

## Schedule - C

(See Clause 2.1)

### PROJECT FACILITIES

#### 1. Project Facilities

The Contractor shall construct the Project Facilities in accordance with the provisions of this Agreement. Such Project Facilities shall include:

- (a) Roadside furniture.
- (b) Pedestrian facilities.
- (c) ~~Highway lighting~~
- (d) Landscaping and Tree Plantation
- (e) Bus shelter
- (f) ~~Painting~~
- (g) Utility pipes

#### 2. Description of Project Facilities

Each of the Project Facilities is briefly described below:

**a) Roadside Furniture shall be provided as follows: -**

Traffic Signs, Solar blinkers and Pavement Markings:

Traffic signs and pavement markings shall include roadside signs, overhead signs, curve mounted signs and road marking along the project highway. Aluminium Composite Material (ACM) sheets shall be used for sign boards. Singage plan is enclosed for reference. The locations for these provisions shall be finalised in consultation with Authority and as per **IRC: 67 and IRC: 35** Standard. The detailed signage plan indicating places, direction, distances and other features marked on the change plan shall be prepared as per manual requirements, and the same shall be finalized in consultation with PWD as per site requirement.

Traffic Safety Devices shall be provided in consultation with Authority & Latest IRC standards.

Road studs, Flexible median markers, Roadway Delinators, reflective pavement markers, reflective stickers for the road side hazards (Trees, electrical poles, Buildings/shops/compound walls), convex mirrors, Solar Blinkers and Bollards shall be provided in accordance with Schedule-D.

Transverse Zebra Crossing Markings shall be provided at all crossroad junction as

per IRC: 35.

Hazard Markers as per IRC standards.

Solar Traffic blinker signal (L.E.D) and Convex mirrors shall be provided at intersections.

Existing Non standards sign boards shall be removed.

Table top crossings, transverse bar markings shall be provided at all crossroad junction as per IRC: 99.

#### **b) Pedestrian Facilities**

Pedestrian Facilities shall be provided in accordance with the Manual of Specifications and Standards as referred in Schedule D and IRC 103 2022.

Pedestrian Facilities include the provision of:

##### **i) Pedestrian Guard Rail:**

Pedestrian Guard Rails of Stainless steel shall be provided on minor bridge, footpath, each bus bay, bus shelter location, built-up sections and intersections as specified in the manual.

##### **ii) Pedestrian crossings:**

Pedestrian crossings shall be provided at built-up sections and intersections as specified in the manual.

The additional pedestrian facilities in the form of guard rails, footpath, lighting etc. shall be provided in built-up area. Raised Footpath shall be provided with paver blocks.

#### **c) ~~Highway Lighting~~**

~~Streetlight: Street lighting on decorative lamp post with LED /energy efficient lighting system of standard make with minimum 40 Lux capacity shall be provided for service road sections.~~

#### **Note: -**

- I) The above specified locations are minimum specified. If required, the Contractor shall provide high mast lighting wherever necessary in consultation with the Authority. However, this shall not be treated as Change of Scope.
- ii) Solar lights blinkers shall be provided at major junctions etc.
- iii) The lighting work shall be got done from the qualified specialised agency.
- iv) The scope includes providing entire lighting systems, trenching, underground / building in cabling, transformers etc. and obtaining electric supply / approval from concern Govt. department, if required.

**Note:** After construction, erection and energizing same shall be

maintained/replaced, if required, till maintenance period by the Contractor.

**d) Landscaping and Tree Plantation**

a) Landscaping/turfing of the highway shall be done for the at grade junctions as per IRC: SP: 21. Tree plantation for 600 nos. of tree.

b) Dismantling and reconstruction of kerbs on Center island and Splitter islands shall be done.

**e) Bus shelter**

Bus shelter shall be provided at the locations given below. Bus shelter shall be designed based on IRC: SP:84, Clause 12.7 and Figure 12.3.

S. No.	Design Chainage (Km)	Side	Location Name
1	586.150	RHS	On MDR Side
2	586.100	LHS	On service road
3	586.200	LHS	On service road

**Note:-** The locations of the Bus shelter are tentative & shall be approved / provided in consultation with the Authority / Authority's Engineer.

**f) ~~Painting:~~**

~~Mural painting shall be provided for RE walls, Girders and Abutments of VUPs located as per design, colour scheme, and specifications approved by the Authority.~~

**g) Utility pipes:**

PVC pipes or ducts are installed beneath the footpath to provide safe, protected routing for electricity cables, optical fiber cables, and water supply networks as per site-specific requirements and IRC/MORTH standards for highway utility corridors.

**H) Facilities to be provided to the Employer for Project Supervision/Monitoring:**

The Contractor shall provide a vehicle - Ertiga or equivalent, not more than five years old for the use of Office of the Executive Engineer, WD-XIV(NH), Fatorda, Goa for the period of one year from the date of appointment or for further extended period as directed by the Authority. This provision shall be incidental to the work and shall not be paid for extra.

## Schedule - D

(See Clause 2.1)

### SPECIFICATIONS AND STANDARDS

#### 1. Construction

The Contractor shall comply with the Specifications and Standards set forth in **Annex-I** of this **Schedule-D** for construction of the Project Highway.

#### 2. Design Standards

The Project Highway including Project Facilities shall conform to design requirements set out in the following documents:

- Manual of Specifications and Standards for Four Laning of Highways (IRC: SP: 84-2019) referred to herein as the Manual for 4-Lane project road.
- All materials, works & Construction operation shall conform to MORTH Specifications for Road and Bridge Works, IRC:58-2015 for Rigid Pavement Design, IRC:37-2018 for Flexible Pavement Design and other IRC codes based on design requirements.
- The provision of mandatory use of factory manufactured precast concrete elements in project within 100 km radius of the precast factory shall be governed by Ministry's Circular No. RW/NH-34049/01/2020-S&R(B) dated 08.04.2022. The minimum mandatory usage should be 25% of the total concrete volume other than the foundations and substructures of bridges/via duct/ ROB. Any relaxation may be granted by Authority only if the Contractor/Contractor is able to demonstrate that the manufacturer(s) is not able to provide such products matching to the works programme of the Contractor or the prices demanded by the manufacturer is more than the prices derived for cast-in-situ condition at the rates of SoR prevailing on 28th days before the bid due date.
- The use of fly ash in road/ flyover embankment construction on national highways work shall be governed by Ministry's Circular No. RW/NH-33044/01/2019-S&R(P&B) RSCE-Pt.1 dated 18.04.2022 and guidelines/ notification issued by MoEF& CC and MOP and applicable guidelines of Indian IRC & BIS.
- The use of UHPFRC shall be governed by Ministry's Circular No. RW/NH-33049/01/2020-S&R (B) Pt. dated 22.02.2022
- The use of manufactured aggregates in National Highway works shall be governed by Ministry's Circular No. RW/NH-34066/09/2017-S&R(B) dated 21.07.2020.
- Toll Plaza shall be governed by NHA Circular No. NHA/Policy Guidelines/Management of Plaza/2021, Policy Circular No. 17.5.82 Dated 24th May 2021.
- Circular No. RW/NH-34066/09/2017-S&R (B) dated 12.02.2021 on reinforcing

Construction of service roads, improvement of junction and curves between km 585.600 to 593.340 km along Canacona bypass section of NH-66 in the State of Goa.

- Steel Bars: Clause 100.9.3.1 of Ministry's Specifications for Road and Bridge Works and Circular No. RW/NH-34049/03/2020-S&R(B) dated 22.01.2021 on use of Stainless Steel in Bridges on National Highways to be constructed in marine Environment Susceptible to Severe Corrosion.

**Note:** -Latest revisions of all relevant codes published 28 days before NIT date shall be applicable for this tender.

Annex - I  
(Schedule-D)

**SPECIFICATIONS AND STANDARDS FOR CONSTRUCTION**

**1 Specifications and Standards**

All Materials, works and construction operations shall conform to the Manual of Specifications and Standards for Four Laning of Highway through PPP (IRC: SP: 84-2019) and MORTH Specifications for Road and Bridge Works. Where the specification for a work is not given, Good Industry Practice shall be adopted to the satisfaction of the Independent Engineer.

Following Manual or references shall be followed

Reference	Description
<b>Primary References</b>	
IRC:SP:88	Road Safety Audit Manual
IRC:SP:84	Manual of Specifications and Standards for Four Laning of Highways
IRC:SP:55	Guidelines on Traffic Management in Roads
IRC:103	Guidelines for Pedestrian Facilities
IRC:67	Code of Practice for Road Signs
IRC:35	Code of Practice for Road Markings
IRC: 99	Guidelines on Traffic Calming measures in Urban and rural Roads
IRC SP 63	Guidelines for the use of Interlocking concrete block pavement
<b>Other References</b>	
IRC:SP:44-1996	Highway Safety Code
MoRTH	Manual for Safety in Road Design
IRC:SP:32	Road Safety for Children (5-12 Years old)
IRC:SP:31	New Traffic Signs
IRC:119	Guidelines for Traffic Safety Barriers

Construction of service roads, improvement of junction and curves between km 585.600 to 593.340 km along Canacona bypass section of NH-66 in the State of Goa.

IRC:37	Guidelines for the Design of Flexible Pavements
IRC:SP-85	Guidelines for Variable Message Signs
IRC:73	Geometric Design Standards for Rural (Non-Urban) Highways
IRC:66	Recommended Practice for Sight Distance on Rural Highways
IRC:SP:23	Vertical Curves for Highways
IRC:53	Road Accident Forms A-1 and 4
MoRTH	National Road Safety Policy
MoRTH	Sundar Committee Report on Road Safety and Traffic Management
Additional References	
MoRTH Circular 602	Road Signs & Markings
MoRTH Circular 604	Highway Safety Railings
MoRTH Circular 605	Traffic Regulation
MoRTH Circular 606	Accidents
MoRTH Circular 607	Highway Patrolling
MoRTH Circular 1920	Safety measures
IRC:2	Route Marker Signs for National Highways
IRC:8	Type Designs for Highway Kilometer Stones
IRC:11	Recommended Practice for the Design and Layout of Cycle Tracks
IRC:31	Route Marker Signs for State Routes
IRC:62	Guidelines for Control of Access of Highways
IRC:64	Guidelines for Capacity of Roads in Rural Areas
IRC:79	Recommended Practice for Road Delineators
IRC:80	Type Designs for Pick-up Bus Stops on Rural (i.e., Non-Urban) Highways
IRC:93	Guidelines on Design and Installation of Road Traffic Signals

Construction of service roads, improvement of junction and curves between km 585.600 to 593.340 km along Canacona bypass section of NH-66 in the State of Goa.

IRC:SP:41	Guidelines on Design of At-Grade Intersections in Rural & Urban Areas
IRC 112	Guidelines on Practice for Concrete road bridges
IRC 6	Guidelines on standard specifications and code for road bridges
IRC SP 56	Guidelines for Steel Pedestrian Bridges
MoRTH	Type Designs for Intersections on National Highways, 1992
NBC/IS Codes	Relevant guidelines for Installation, inspection, Maintenance and Operation of Lifts and Escalators
References from other countries / practices	
AASHTO	Highway Safety Manual
AASHTO	Highway Safety Design and Operations Guide
AASHTO	AASHTO Safety Leadership Forum V – Toward Zero Deaths (TZD): Aggressive Plans to Meet Aggressive Goals .
AASHTO	AASHTO Strategic Highway Safety Plan -- A Comprehensive Plan to Substantially Reduce Vehicle-Related Fatalities and Injuries on the Nation's Highways

## 2 Deviations from the Manual

Notwithstanding anything to the contrary contained in the aforesaid Manual, the following Specifications and Standards shall apply to the Project Highway, and for purposes of this Agreement, the aforesaid Specifications and Standards shall be deemed to be amended to the extent set forth below:

S.no	Item	Clause in Manual	Provision as per Manual	Modified Provision
1	Typical Cross section	2.1 7	TCS as given in Fig. 2.2 to 2.3	As per modified TCS given in Schedule-B

Construction of service roads, improvement of junction and curves between km 585.600 to 593.340 km along Canacona bypass section of NH-66 in the State of Goa.

**IRC Codes: (Latest revision)**

- IRC:5-2015 Standard Specifications and Code of Practice for Road Bridges, Section I - General Features of Design
- IRC:6-2017 Standard Specifications and Code of Practice for Road Bridges, Section-II Loads and Combinations
- IRC:38 - Guidelines for Design of Horizontal Curves for Highways and Design Tables
- IRC:58-2015 Guidelines for the Design of Plain Jointed Rigid Pavements for Highways (Fourth Revision).
- IRC:37-2018 Guidelines for the Design of Flexible Pavements (Fourth Revision).
- IRC:83-2015 (Part I) Standard Specifications and Code of Practice for Road Bridges, Section IX- Bearings, Part I : Roller & Rocker Bearings
- IRC:83-2018 (Part II) Standard Specifications and Code of Practice for Road Bridges, Section IX - Bearings (Elastomeric Bearings), Part II
- IRC:83-2018 (Part III) Standard Specifications and Code of Practice for Road Bridges, Section IX - Bearings, Part III: POT-CUM-PTFE, PIN and Metallic Guide Bearings
- IRC:119 - 2015 - Guidelines for Traffic Safety Barriers
- IRC: SP:23 - Vertical Curves for Highways
- IRC: SP:42 - Guidelines on Road Drainage
- IRC: SP:84-2019 Manual of specifications & Standards for Four Laning of Highways with Paved Shoulders.
- IS: 6006-1983 (Reaffirmed 2008) - Specification for Uncoated Stress Relieved Strand for Pre-Stressed Concrete

The above latest version of IRC Codes and all other relevant latest IRC applicable as on 28 days prior to bid due date to be considered.