

(For non overlapping consecutive compressive test result any one alternate set of four samples shall be used for verification of compliance to clause no. 16.1.a of IS 456)

- b) The strength determined from any test result is not less than the specified characteristic strength less 0.3 N/mm^2

Table-5

(Refer Cl. 16.1 & 16.3 of IS 456)

Characteristic Compressive Strength Compliance Requirement

Specified Grade	Mean of the Group of 4 Non-Overlapping Consecutive Test Results in N/mm^2	Individual Test Results in N/mm^2
M15 or above	$\geq f_{ck} + 0.825 \times \text{established standard deviation}$ (rounded off to nearest 0.5 N/mm^2) or $\geq f_{ck} + 3 \text{ N/mm}^2$, Whichever is greater	$\geq f_{ck} - 3 \text{ N/mm}^2$
NOTE : 1) In the absence of established value of standard deviation, the values given in Table 8 of IS 456, Amendment No. 4, may be assumed, and attempt should be made to obtain results of 30 samples as early as possible to establish the value of standard deviation. 2) For concrete of quantity 30 m^3 (where the number of samples to be taken is less than four as per the frequency of sampling given in cl. 15.3.4, Table 4), the mean of test results of all such samples shall be $f_{ck} + 4 \text{ N/mm}^2$, minimum and the requirement of individual test results shall be $f_{ck} - 2 \text{ N/mm}^2$, minimum. However, when the number of sample is only one as per Table 4, the requirement shall be $f_{ck} + 4 \text{ N/mm}^2$.		

15.3.9.3 Quantity of Concrete Represented by Strength Test Results

The quantity of concrete represented by group of four consecutive test results shall include the batches from which first and last samples were taken together with all intervening batches. Acceptance of concrete shall be applicable for serially logged 30 samples. In case serially logged samples are less than 30 then standard deviation of adjoining previous sample sets will be used for establishing acceptance criteria as per clause 16.1.a of IS 456.

For the individual test result requirements given in col. 3 of Table-5 or in item (b) of 15.3.9.2, only the particular batch from which the sample was taken shall be at risk.

Where the mean rate of sampling is not specified, the maximum quantity of concrete that four consecutive test results represent shall be limited to 60 m^3 .

- 15.3.9.4 If the concrete is deemed not to comply pursuant to Cl. 15.3.9.1 or 15.3.9.2, the structural adequacy of the parts affected shall be investigated and any consequential action as needed shall be taken (Refer Cl. 16.0).

- 15.3.9.5 Concrete of each grade shall be assessed separately.

- 15.3.9.6 Concrete is liable to be rejected if it is porous or honey-combed, its placing has been interrupted without providing a proper construction joint, the reinforcement has been displaced beyond the tolerances specified, or construction tolerances have not been met. However, the hardened concrete may be accepted after carrying out suitable remedial measures and tests to the fullest satisfaction of the Engineer-in-Charge.

- 15.3.9.7 Tolerance in leveling of concrete surface at foundation/ pedestal top level where grouting is to be done:

Maximum Plan Dimension	$\leq 2\text{m}$	$>2\text{m but } \leq 4\text{m}$	$> 4\text{m}$
Tolerance in leveling	+ 10 mm	+ 10 mm	+ 10 mm
	- 10 mm	- 20 mm	- 25 mm

15.3.9.8 Tolerance in dimensions of pocket:

20 mm overall maximum tolerance on the size of pocket.

For pockets, chemically dissolvable moulds shall be preferred. Smooth removal of moulds without affecting the pocket size shall be ensured.

16.0 INSPECTION AND TESTING OF STRUCTURES

16.1 Inspection

To ensure that the construction complies with the design, an inspection procedure shall be set up by the contractor and duly approved by the Engineer-in Charge covering materials used, receipt of materials, their test results, records, workmanship and construction etc.

Contractor shall ensure that the surface which is to receive the grout is at proper level and so are the openings for pockets as per Cl. 15.3.9.7 & 15.3.9.8.

16.2 Immediately after stripping the formwork, all concrete shall be carefully inspected and any defective work or small defects either removed or made good before concrete has thoroughly hardened.

16.3 Testing

In case of doubt regarding the grade or soundness of concrete used, either due to poor workmanship or based on results of cube strength, compressive strength tests of concrete on the basis of clause 17.4 of IS 456 and/or load test as per clause 17.6 of IS 456 shall be carried out.

The Engineer-in-Charge shall be the final authority for interpreting the results of all tests and shall decide upon the acceptance or otherwise. The decision of the Engineer-in-Charge shall be final and binding on the contractor. In case the results of the tests are unsatisfactory, the Engineer-in-Charge may instruct the contractor to demolish and reconstruct the structure or part thereof without any extra cost to the Owner.

16.4 Members other than Flexural Members

Members other than flexural members like columns etc. shall be referred to the designer to investigate the structural adequacy. The decision of the designer shall be final and binding on the contractor.

16.5 Non-destructive Tests

Non-destructive tests using Ultrasonic Pulse Velocity and Rebound Hammer methods shall be resorted to for checking the soundness of concrete placed and shall be as per the directions of Engineer-in-Charge. The testing shall be based on IS 13311, Part-1. However, the Rebound Hammer test (IS 13311, Part-2) shall only be used in combination with other tests (Destructive or Non-Destructive) for checking the concrete quality.

17.0 FINISHING OF CONCRETE

17.1 On striking the formwork, all surface defects such as bulges, ridges and honey-combing etc. observed shall be brought to the notice of the Engineer-in-Charge. The Engineer-in-Charge may, at his discretion allow rectification by necessary chipping and packing or grouting with concrete or cement mortar. However, if honey-combing or sagging is of such extent as being undesirable, the Engineer-in-Charge may reject the work totally and his decision shall be binding. No extra payment shall be made for rectifying these defects, demolishing and reconstructing the structure. However, quantity of cement actually used for this purpose may

be considered for reconciliation of materials. All burrs and uneven faces shall be rubbed smooth with the help of carborundum stone.

The surface of non-shuttered faces shall be smoothed with a wooden float to give a finish similar to that of the rubbed down shuttered faces. Concealed concrete faces shall be left as from the formwork except that honey-combed surface shall be made good as specified above. The top faces of slabs not intended to be covered shall be levelled and floated to a smooth finish to the rises or falls shown on the drawings or as directed. The floating shall not be executed to the extent of bringing excess fine materials to the surface. The top faces of slabs intended to be covered with screed, granolithic or similar finishes, shall be left with a rough finish.

17.2 Repair and Replacement of Unsatisfactory Concrete

- 17.2.1 Repair shall be made as soon as possible after the forms are removed and before the concrete becomes too hard with prior permission from the Engineer-in-Charge, in writing. Stone pockets, segregation patches and damaged areas shall be chipped out and the edges undercut slightly to form a key. All loose material shall be washed out before patching. No excess water shall be left in the cavity, but the concrete shall be damp. A good bond between the patch and parent concrete shall be obtained by sprinkling dry cement on the wet surface or by throwing mortar with force on to the wetted concrete, or by brush in a coat of thick cement grout of about 1:1 (1 cement:1 sand) just before applying the patching material. Before this has dried, the remainder of the patch shall be filled with mortar or concrete, depending on the extent of the repair.
- 17.2.2 Cement concrete/mortar used in repair of exposed surfaces shall be made with cement from the same source as that used in concrete and blended with sufficient amount of white Portland cement to produce the same colour as in the adjoining concrete. The proportions of ingredients shall be same as those used in parent concrete. The mortar shall be as dry as possible and well compacted into the cavity. All filling shall be tightly bonded to the concrete and shall be sound, free from shrinkage cracks after the filling has been cured and dried.
- 17.2.3 For larger repairs to hardened concrete, necessary formwork bearing tightly at the edges of the cavity shall be provided. Concrete shall be chipped out to a depth of at least 100 mm and preferably 150 mm. Mortar shall be scrubbed into all surfaces with a wire brush before placing the concrete. Damaged reinforcement shall be adequately spliced with new steel so as to maintain the original strength. Additional reinforcement, if required in the patch, shall be provided as per the instructions of Engineer-in-Charge.
- 17.2.4 In case, in the opinion of the Engineer-in-Charge, defects in the concrete is excessive or beyond repair, the contractor shall either redo the structure or take other remedial measures as instructed by the Engineer-in-Charge. The decision of the Engineer-in-Charge shall be final and binding to all in this respect.
- 17.2.5 Approved epoxy formulation for bonding fresh concrete used for repairs with already hardened concrete shall be used by the Contractor if asked by the Engineer-in-Charge. Epoxy shall be applied in strict accordance with EIL Specification 6-68-0056 and the instructions of the manufacturer.
- 17.2.6 All repair works due to non-conformance or non-adherence to specification, if allowed by the Engineer-in-Charge, shall be carried out free of cost to the owner.

17.3 Curing of Patched Work

Immediately after patching is completed, the patched area shall be covered with an approved non-staining water saturated material which shall be kept wet and protected against sun and wind for a period of 12 hours. Thereafter, the patched area shall be kept continuously wet by a fine spray or sprinkling for not less than 10 days.

18.0 WATERPROOF CEMENT PAINT

Wherever specified, concrete elements (whether cast-in-situ or precast) exposed to atmosphere shall be provided with three coats of cement based waterproof paint as per IS 5410 provided these surfaces shall not contain any protective coating. Prior to application of the paint, the surface shall be prepared to remove all foreign particles, loose materials, extra deposited concrete lumps, etc. using appropriate mechanical/ manual means.

19.0 FORM WORK

19.1 General

19.1.1 Forms for concrete shall be of plywood conforming to IS 6461 (Part-5) or steel or as directed by the Engineer-in-Charge and shall give smooth and even surface after removal thereof.

19.1.2 If it is desired by Engineer-In-Charge, the Contractor shall prepare, before commencement of actual work, design and drawings for formwork and get them approved by the Engineer-in-Charge. For details regarding design, detailing etc., reference may be made to IS 14687.

19.1.3 Form work and its supports shall maintain their correct position and be to correct shape and profile so that the final concrete structure is within the limits of dimensional tolerances specified below, unless required otherwise, for functional/aesthetic reasons. The decision of the Engineer-in-Charge shall be final and binding in this regard.

- | | |
|--|--|
| (a) Deviation from specified dimensions of cross section of columns and beams. | - 5 mm to +10 mm |
| (b) Deviation from dimensions of footings (see Note below) | |
| i) Dimensions in plan | -10 mm to +50 mm |
| ii) Eccentricity | 0.02 times the width of the footing in the direction of deviation but not more than 50 mm. |
| iii) Thickness | -10 mm to +50 mm or ± 0.05 times the specified thickness, whichever is less |

Note: These tolerances apply to Cast-in-situ concrete dimensions only, not to positioning of vertical reinforcing steel or dowels.

- | | |
|---|-------------|
| (c) Deviation in length (major dimension of single unit) | |
| upto 3m | ± 6 mm |
| 3m to 4.5m | ± 9 mm |
| 4.5m to 6m | ± 12 mm |
| Additional deviation for every subsequent 6m. | ± 6 mm |
| (d) Deviation in straightness or bow (deviation from specified line) for a single or continuous member) e.g. beam, column or slab edge. | |
| upto 3m | 6 mm |
| 3m to 6m | 9 mm |
| 6m to 12m | 12 mm |
| additional for every subsequent 6m. | 6 mm |

- (e) Deviation in squareness shall be measured taking the longer of two adjacent sides as the base line.

The shorter side shall not vary in its distance from a perpendicular so that the difference between the greatest and shortest dimensions exceeds 6 mm. For this purpose, any error due to lack of straightness shall be ignored. Squareness shall be checked with respect to the straight lines that are most nearly parallel with the features being checked. When the nominal angle is other than 90 degree, the included angle between check lines shall be varied accordingly.

- (f) Deviation in twist shall be within a limit such that any corner shall not be more than the limit given below from the plane containing other three corners:

upto 600 mm wide and upto 6m in length	:	6 mm
over 600 mm wide and for any length	:	12 mm

- (g) Maximum deviation in flatness from a 1.5m straight edge placed in any position on a nominally plain surface shall not exceed 6 mm.

- (h) Tolerance in leveling of concrete surface at foundation/
pedestal top level where grouting is to be done : As per Cl. 15.3.9.7

19.2 Form Requirement

- 19.2.1 The formwork shall be true, rigid and adequately braced both horizontally as well as diagonally. The forms shall have smooth and even surface and be sufficiently strong to carry, without deformation, the dead weight of the green concrete, working load, wind load and also the side pressure exerted by the green concrete. As far as practical, clamps shall be used to hold the forms together. Where use of nails is unavoidable minimum number of nails shall be used. Projected part of nail shall not be bent or twisted for easy withdrawal.
- 19.2.2 Where through tie rods are required to be put to hold the formwork and maintain accurate dimension, they shall always be inserted through a precast concrete block (of same mix proportion as is to be used for concreting) with a through hole of bigger diameter. The Precast block shall tightly fit against in inner faces of formwork. The holes left after the withdrawal of tie rods shall be fully grouted with cement-sand mortar of same proportion as that used for concrete. However, use of such precast block shall in no case impair the desired appearance or durability of the structure. No such tie rods shall be used in any liquid retaining or basement structure.
- 19.2.3 Tie wires shall be permitted only upon approval of the Engineer-in-Charge and shall be cut off flush with the face of the concrete or counter sunk, filled and finished in the manner specified in clause 17.
- 19.2.4 Form joints shall not permit any leakage. The formwork shall be strong enough to withstand the effect of vibrations practically without any deflection, bulging, distortion or loosening of its components.
- 19.2.5 Forms for beams and slabs (span more than 6.0m) shall have camber of 1 in 500 so as to offset the deflection and assume correct shape and line after deposition of concrete. For cantilevers, the camber at free end shall be 1/100th of the projected length. Where architectural considerations and adjunctive work are critical, smaller form cambers shall be adopted as decided by the Engineer-in-Charge.

- 19.2.6 All vertical wall forms may be designed and constructed for the following minimum pressure. The pressures listed in Table-6 are intended as guide only and the Contractor shall ensure that the formwork is adequately strong and sturdy.

TABLE - 6
MINIMUM DESIGN PRESSURE FOR WALL FORMWORK

Rate of pour in meter/hour	Pressure in KN/m ²	
	at 10 ⁰ (in Celsius)	at 24 ⁰ (in Celsius)
0.6	36.0	29.0
0.9	40.0	32.0
1.2	44.0	35.0
1.5	46.0	37.0

All horizontal forms shall be designed and constructed to withstand the dead load of the green concrete, reinforcement, equipment, material, embedment and a minimum live load of 2.0 kN/m².

19.3 Inspection of Forms

Temporary openings shall be provided at the base of column and wall forms and other places necessary to facilitate cleaning and inspection. Before concrete is placed, all forms shall be carefully inspected to ensure that they are properly placed, sufficiently rigid and tight, thoroughly cleaned, properly treated and free from foreign material. The complete form work shall be inspected and approved by the Engineer-in-Charge before the reinforcement bars are placed in position. When forms appear to be unsatisfactory in any way, either before or during the placing of concrete, the work shall be stopped until the defects have been rectified as per the instructions of the Engineer-in-Charge.

19.4 Cleaning and Treatment of Formwork

The surfaces of forms that would come in contact with concrete shall be well treated with approved non-staining form release agents such as soft soap, oil, emulsions etc. Release agents shall be applied so as to provide a thin uniform coating to the forms without coating the reinforcement.

19.5 Chamfers and Fillets

All corners and angles shall be formed with 45 degree mouldings to form chamfers or fillets on the finished concrete. The standard dimensions of chamfers and fillets, unless otherwise detailed or specified shall be 25x25 mm. For heavier work chamfers or fillets shall be 50x50 mm. Care shall be exercised to ensure accurate mouldings. The diagonal face of the moulding shall be planed or surfaced to the same texture as the forms to which it is attached.

19.6 Reuse of forms

Before reuse, all forms shall be thoroughly scrapped, cleaned, examined and when necessary, repaired and retreated, before resetting. Formwork shall not be reused, if declared unfit or un-serviceable by the Engineer-in-Charge.

19.7 Removal of Forms/Stripping Time

In the determination of time for removal of forms, consideration shall be given to the location and character of the structures, the weather and other conditions including the setting and curing of the concrete and material used in the mix.

Forms and their supports shall not be removed without the approval of the Engineer-in-Charge. Forms shall not be released until the concrete has achieved a strength of at least twice the stress to which the concrete may be subjected at the time of removal. The formwork shall be removed without shock and methods of form removal likely to cause over stressing or damage to the concrete shall not be adopted. Supports shall be removed in such a manner as to permit the concrete to uniformly and gradually take the stresses due to its own weight.

In normal circumstances when average air temperature exceeds 15 degree Celsius during the period under consideration after pouring of concrete and where ordinary Portland cement is used, forms may generally be removed after expiry of following periods.

- | | |
|---|---|
| (a) Walls, columns and vertical faces of all structural members | 16 to 24 hours as may be decided by the Engineer-in-Charge. |
| (b) Slabs (props left under) | 3 days. |
| (c) Beam Soffits (props left under) | 7 days. |
| (d) Removal of props under slabs: | |
| Spanning upto 4.5m. | 7 days. |
| Spanning over 4.5m. | 14 days. |
| (e) Removal of props under beams and arches: | |
| Spanning upto 6m | 14 days. |
| Spanning over 6m | 21 days |
| (f) Cantilever Construction Formwork shall remain till structures for counter acting or bearing down have been erected and have attained sufficient strength (minimum 14 days). | |

Notes:

- i) For other cements, the stripping time recommended for ordinary Portland cement shall be suitably modified as per the instructions of the Engineer- in-Charge.
- ii) The number of props left under, their sizes, supporting arrangement, and disposition shall be such as to be able to safely carry the full dead load of the slab, beam or arch as the case may be together with any live load likely to occur during curing or further construction.
- iii) Where the shape of the element is such that the formwork has re-entrant angles, the form work shall be removed as soon as possible after the concrete has set, to avoid shrinkage cracking occurring due to the restraint imposed.
- iv) For rapid hardening cement, 3/7 of the above mentioned periods shall be considered subject to a minimum of 16 hours.
- v) For Portland pozzolana or low heat cement, 10/7 of the above mentioned periods shall be considered.

19.8 Staging/Scaffolding

- 19.8.1 Staging/Scaffolding shall be properly planned and designed by the Contractor. Use of only steel tubes is permitted for staging/scaffolding. The Contractor shall get it reviewed by Engineer-in-Charge before commencement of work. While designing and during erection of scaffolding/staging, the following measures shall be considered:

- (a) Sufficient sills or underpinnings in addition to base plates shall be provided particularly where scaffolding is erected on soft grounds.
- (b) Adjustable bases to compensate for uneven ground shall be used.
- (c) Proper anchoring of the scaffolding/staging at reasonable intervals shall be provided in each direction with the main structure wherever available.
- (d) Horizontal braces shall be provided to prevent the scaffolding/staging from rocking.
- (e) Diagonal braces shall be provided continuously from bottom to top between two adjacent rows of uprights.
- (f) The scaffolding/staging shall be checked at every stage for plumb line.
- (g) Wherever the scaffolding/staging is found to be out of plumb line it shall be dismantled and re-erected afresh and effort shall not be made to bring it in line with a physical force.
- (h) All nuts and bolts shall be properly tightened and care shall be taken that all clamps/couplings are firmly tightened to avoid slippage
- (i) Erection work of a scaffolding/staging under no circumstances shall be left totally to semi-skilled or skilled workmen and shall be carried out under the supervision of a technically qualified civil engineer of the Contractor.

19.8.2 For smaller works or works in remote areas, wooden ballies may be permitted for scaffolding/staging by the Engineer-in-Charge at his sole discretion. The contractor must ensure the safety and suitability of such works as described under clause 19.8.1 above.

20.0 EXPOSED/ARCHITECTURAL CONCRETE WORK

20.1 Form Work

Other things remaining same as per clause 19.0, formwork shall be of high quality. Care shall be taken to arrange the forms so that the joints between forms correspond with the pattern indicated in the drawings. The forms shall be butting with each other in straight lines, the corners of the boards being truly at right angles. The joints between the forms shall cross in the two directions at right angles. The size of forms shall be so selected as to exactly match with the pattern of forms impression on the concrete face indicated in the drawings. Maximum care shall be taken to make the form work watertight. Burnt oil shall not be used for treatment of forms. The Contractor shall be permitted reuse of forms brought new on the work place only if forms are properly cared for, stored and treated after each use.

The Engineer-In-Charge may, at his absolute discretion, order removal of any forms considered unsuitable for use in the work.

20.2 Finishing

Repairing to exposed concrete work shall be avoided. Rendering and plastering shall not be done. Minor repairing, if unavoidable shall be done as specified in clause 17.0 with the written permission of the Engineer-in-Charge.

21.0 REINFORCEMENT

21.1 The Contractor shall develop the bar bending schedule for all RCC structures/ structural parts at no extra cost to the Owner and shall get it reviewed by the Engineer-in-charge. Reinforcement shall be cut and bent to shape as per dimensions shown in the bar bending schedule/ drawings.

If protective fusion bonded epoxy coating is required to be applied on reinforcement bars, the same shall be done as per IS 13620. All repairs to applied protective coating required due to mishandling and/ or bending of reinforcement bars shall also be done as per relevant clauses of IS 13620.

21.2 Straightening, Cutting and Bending

Procedure for cutting and bending shall be as given in IS 2502. Bars shall be bent in a slow and regular movement to avoid fractures by mechanical means only. In case bars are supplied in coils, they shall be smoothly straightened without any kinks.

Cold twisted deformed bars shall be bent cold. Bars larger than 25 mm in size (except cold twisted deformed bars) may be bent hot at cherry red heat to a temperature not exceeding 850⁰ Celsius as per the instructions of the Engineer-in-Charge. The bars shall be allowed to cool gradually without quenching.

Bars shall be cut & bend in a Bar Bending Machine. Bars which develops cracks or splits after bending shall be rejected. A second bending of reinforcement bars shall be avoided but when reinforcement bars are bent aside at construction joints and afterwards bent back into their original position, care should be taken to ensure that at no time is radius of the bend less than 6 times bar diameter for high strength deformed bars. Care shall also be taken when bending back the dowel bars to ensure that concrete around the bars is not damaged. All bars shall be properly tagged for easy identification.

21.3 Placing and Fixing

All reinforcement shall be cleaned to ensure freedom from loose mill scale, loose rust, oil, form releasing agents, grease or any other harmful material before placing them in position. Reinforcement shall not be surrounded by concrete unless it is free from all such materials. Rough handling and dropping of reinforcement from a height shall be avoided.

All reinforcement shall be fixed in the correct position and shall be properly supported to ensure that displacement will not occur when the concrete is placed and compacted.

The uncoated reinforcement bars shall be tied at every intersection by two strands of 16 SWG black soft annealed binding wire. The Epoxy coated reinforcement bars shall be tied with 2 strands of PVC coated GI 18 SWG wire at every intersection. Crossing bars shall not be tack welded for assembly of reinforcement. The reinforcement bars shall be kept in position by using the following methods:

- In case of beam and slab construction, precast cover blocks (having the same sand contents as the concrete which shall be placed) of size 40 x 40 mm and thickness equal to the specified covers shall be placed firmly in between the bars and forms so as to secure and maintain the specified covers over the reinforcement.

When reinforcement bars are placed in two or more layers in beams, the vertical distance between the horizontal bars shall be maintained by introducing spacer bars at 1 to 1.2m centre to centre.

- b) In case of thick rafts & pile caps having two or multi layers of reinforcement, the vertical distance between the horizontal bars shall be maintained by introducing suitable chairs, spacers, etc.
- c) In case of columns and walls, the vertical bars shall be kept in position by means of timber templates with slots accurately cut in them. The templates shall be removed after the concreting has been done below it.
- d) Exposed portions of reinforcement bars shall not be subjected to impact or rough handling and workmen will not be permitted to climb on extending bars until the concrete has attained sufficient strength so that no movement of the bars in the concrete is possible.

21.4 Special requirements for Handling, Stacking, Placing of Epoxy coated Reinforcing bars.

Epoxy coated reinforcing bars shall be carefully handled and it shall be ensured that these do not rub on any hard surface or against another epoxy coated/uncoated reinforcing bar whether during conveying/transportation, stacking or placing.

During transportation and while stacking the epoxy coated reinforcing bars shall be placed on wooden planks not spaced farther than 600 mm. When placed in stacks the epoxy coated reinforcing bars shall be neatly tied in bundles using PVC binding material.

The cut ends of bars shall be touched up with special touch up material of specifications as provided by the coating agency. After cutting of the bar the application of touch up material shall be completed within four hours.

While bending the bars the pins of work bench(s) shall be provided with a PVC or plastic sleeve. Each bending operation on epoxy coated reinforcing bar shall be completed in time not less than 90 seconds.

Epoxy coated reinforcing steel bar shall not be directly exposed to sun rays or rain, and shall be protected with opaque polyethylene sheets or similar means as approved by the Engineer in Charge.

While doing concreting the workmen or machinery shall not rest or move on the epoxy coated reinforcing bars. Wooden planks shall suitably be placed to create proper gang-way.

21.5 Splicing/Overlapping

Only bars of full length shall be used as shown in the drawings. But where this cannot be done, overlapping of bars shall be done as directed by the Engineer-in-Charge. The overlapping bars shall be tied with two strands of 16 SWG black soft annealed binding wire. The overlaps shall be staggered for different bars and located at points along the span where neither shear nor bending moment is maximum.

21.6 Welded Joints

Welding of reinforcing bars shall not be permitted without the written permission of the Engineer-in-Charge. Where welding of reinforcing bars is permitted, it shall be in accordance with the recommendations of IS 2751 and IS 9417. Welded joints shall be located at suitable staggered positions. Tests shall be made as directed by the Engineer-in-Charge to prove that the joints are of the full strength of the bars. Maximum one welded joint shall be allowed per bar.

21.7 Mechanical Connections

The mechanical splices in reinforcement by means of couplers, clamps etc. shall be used (as per manufacturer's specifications) with the written approval of the Engineer-in-Charge. Following tests, at the minimum, shall be conducted in advance to prove efficiency of the coupled joint before putting them in actual use. This covers requirements of couplers to be used with bars conforming to grades less than & equal to Fe550D of IS 1786.

Name of the Test	Testing Requirement	Code of conformance
<p><u>Static Tensile test:</u></p> <p>1. Tensile strength</p>	<p>Each connection shall develop at least 125% of the specified yield strength of the reinforcing bar & 100% of the specified tensile strength.</p> <p>Bar break requirement shall be satisfied to avoid splice failure & to develop full tensile strength of the bar.</p>	<p>ASTM A370/ ACI 318/ AC 133/ ISO 15835/ IS 16172</p>
<p><u>Static Tensile test:</u></p> <p>2. Percentage elongation (Ductility)</p>	<p>The minimum percentage elongation (at maximum forces), in the reinforcing bar outside the length of the mechanical splice shall be minimum 3% before the failure of the test piece.</p>	<p>ISO 15835 IS 16172</p>
<p>Static compression test</p>	<p>Each connection shall develop atleast 125% of the specified yield strength of the reinforcing bar.</p>	<p>ASTM A370/ ACI 318/ AC 133</p>
<p>Permanent Elongation (Slip)</p>	<p>Permanent elongation across the coupled joint shall be less than 0.1 mm after loading at 60% of the yield strength of the reinforcing bar</p>	<p>BS 8110/ ISO 15835 IS 16172</p>
<p>Cyclic tensile test</p>	<p>Mechanical splice shall withstand 100 cycles of stress variation from 5% to 90% of the yield strength of reinforcing bar & without loss of static tensile strength capacity when compared with like specimen.</p>	<p>IS 16172</p>
<p>Moderate Oligocyclic (Seismic) Test (Cyclic Tension & Compression Test)</p> <p>(Refer note- 1)</p>	<p>Deformation across the coupled joint shall be less than 0.3 mm after subjecting the joint to a series of 20 cycles with 95% tension as well as 50% compression of the yield strength of the reinforcing bar & without loss of static tensile strength capacity when compared with like specimen.</p>	<p>ISO 15835/ ASTM A370/ ACI 318/ AC 133</p>
<p>Violent Oligocyclic (Seismic) Test (Cyclic Tension & Compression Test)</p> <p>(Refer note- 2)</p>	<p>The joint shall be subjected from zero strain upto twice the yield strain in tension followed by compression stress of 50% of yield strength of reinforcing bar for 4 cycles. Thereafter, from zero strain upto five times the yield strain in tension followed by compression stress of 50% of yield strength of reinforcing bar for 4 cycles. Deformation across the coupled</p>	<p>ISO 15835/ ASTM A370/ ACI 318/ AC 133</p>

Name of the Test	Testing Requirement	Code of conformance
	joint shall be less than 0.3 mm after 4 cycles & less than 0.6 mm after 8 cycles & without loss of static tensile strength capacity when compared with like specimen.	
Low cycle fatigue test (Refer note- 3)	Mechanical splice shall withstand 10,000 cycles of alternating tension & compression load from +173Mpa to -173Mpa & without loss of static tensile strength capacity when compared with like specimen.	IS 16172

Notes-

- 1) Moderate Oligocyclic (Seismic) test shall be performed for structures in seismic zone II.
- 2) Violent Oligocyclic (Seismic) test shall be performed for structures in seismic zone III, IV & V.
- 3) Low cycle fatigue test shall be performed for all structures except for concrete structures which are subjected to high cycle of fatigue like machine foundations etc.. For concrete structures which are subjected to high cycle of fatigue, High cycle fatigue test shall be performed as per IS 16172.

All operations relating to reinforcement coupling shall be done by using manufacturer's patented machine/ equipment in the presence of Engineer-in-Charge. Mechanical connections shall be placed away from points of high stress and shall be staggered.

21.8 Tolerances on Placing of Reinforcement

Unless otherwise directed by the Engineer-in-Charge, reinforcement shall be placed within the following tolerances:

- a) For effective depth 200 mm or less ± 10 mm
- b) For effective depth more than 200 mm ± 15 mm

21.9 Substitution

When indicated diameter of reinforcement bar is not available, the Contractor shall use other diameter of reinforcement bars on written approval of the Engineer-In-Charge.

21.10 Tolerance to Cover

The actual concrete cover shall not deviate from the required nominal cover by + 10 mm measured over the steel reinforcement including links.

22.0 PAYMENT

22.1 Plain and Reinforced Concrete

- 22.1.1 Payment for plain and reinforced cement concrete shall be made on cubic metre basis of the volume of the actual finished work done or as per approved construction drawings, whichever is less and shall be inclusive of providing pockets, openings, recesses of all sizes, chamfers, fillets, grooves, separation/ expansion/ isolation/ construction/ movement joints, curing by normal moist curing or using curing compound etc. as directed by Engineer-in-Charge etc. The rates shall be deemed to include complete cost of getting the

respective mix designs approved, making and testing concrete cubes and carrying out other tests including tests of various ingredients, as per specifications and as directed by Engineer-in-Charge. Payment shall, however, be separately made for tests on concrete cubes done by accelerated methods of curing as defined in IS 9013.

- 22.1.2 No separate payment shall be made for any additive/ admixture/ Plasticizer/ Fibres used by the contractor for accelerating or retarding the strength of concrete or for achieving specified workability. The rate quoted shall be deemed to be inclusive of all costs related to any such additive/admixture/ Plasticizer/ Fibres.
- 22.1.3 The rate shall however be exclusive of reinforcement, metal inserts, pipe sleeves, formwork, water stops and any filler material in expansion/isolation joints.
- 22.1.4 Where the strength of concrete mix as indicated by tests, lies in between the strengths of any two grades given in Table-1 and it is accepted by the Owner/Engineer-in-Charge, such concrete shall be classified as a grade belonging to the lower of the two grades between which it lies. In case the cube strength shows higher results than those specified for the particular grade of the concrete, it shall not be placed in the higher grade nor shall the Contractor be entitled for any extra payment on such account. The concrete giving lower strength than specified may be accepted at reduced rates after satisfying the safety of the structure by checking it with tests as specified or rejected entirely at the discretion of the Engineer-in- Charge. The rejected concrete shall be dismantled at no extra cost to the owner and no payment or extension of time shall be granted for the concrete so rejected and the formwork and reinforcement used for the same. Cost of any material supplied by the Owner free of cost shall be recovered from the Contractor at double the prevailing market rate. In case the concrete of lower strength can be improved by carrying out some strengthening measures entirely at the discretion of the Engineer-in-Charge, then the said measures including all related tests shall be carried out by Contractor at his own cost. If the Contractor is able to make up the strength to the required grade by such improvement measures to the entire satisfaction of Engineer-in-Charge, payment shall be made for the grade achieved. However, if the strength of concrete is not made up to the strength of required grade, payment shall be made only for the lower strength if such concrete is accepted by the Engineer-in-Charge.
- 22.1.5 Deductions for openings, pockets etc. shall be as specified in relevant parts of IS 1200.
- 22.1.6 The rate quoted for reinforced cement concrete, also includes single pour concreting wherever specified. The rate shall be inclusive of all extra cost related to labour, shuttering, staging and making all other arrangements for such continuous casting e.g. provisions for adequate movement and storage spaces, special gangways, scaffolding, additional construction equipments, adequate lighting and supervision while the work continues round the clock etc. The rate shall also be inclusive of all costs related to concreting in any thickness, shape and position and at any height or depth so as to avoid any cold joint between specified construction joints.
- 22.1.7 Form Work

Unless otherwise specified, payment for form work shall be on square metre basis of the actual area in contact with the concrete cast. The rates shall be inclusive of keeping the formwork for the full period as specified in the above clauses and removing the same after the period is over. No extra payment shall be made for providing scaffolding/ staging/ access/ stairways/ ladders etc.

The rates shall be inclusive of any provision to be made or kept in the formwork for providing dowels, inserts etc.

Superior quality formwork for exposed/architectural concrete work shall be measured and paid separately under the relevant item in the schedule of rates.

22.2 Reinforcement

- 22.2.1 Payment for plain round mild steel reinforcement bars, high strength deformed steel bars and epoxy coated reinforcing steel bar shall be on the basis of weight of bare steel irrespective of any coating applied in metric tons. The weight of the bar shall be derived from the sizes and corresponding nominal unit weight given in Table-1 of IS 1786. In case actual unit weight of the bars is less than nominal unit weight, but within permissible tolerances, the weight of reinforcement shall be calculated on the basis of actual unit weight. In case actual unit weight of the bars is more than nominal unit weight, the payment shall be made on the basis of nominal unit weight. Standard hook lengths, chairs, spacer bars and authorized laps only shall be included in the weight calculated. Binding wire shall not be weighed nor otherwise measured. Measurements for weight shall not include cutting allowance etc.
- 22.2.2 Rate quoted for reinforcement shall include cost of supplying, decoiling, straightening, cleaning, cutting, bending, placing, binding, welding (if required) and providing necessary cover blocks of concrete.
- 22.2.3 Payment for a mechanical threaded coupler/ clamp shall be made by measuring the Lap length of the respective rebar on which coupler/ clamp is used. The rate shall include supply of complete assembly, fixing, testing etc. all complete.

22.3 Water Stops/Water Bars & Expansion/Isolation Joints

- 22.3.1 Payment for water bars shall be made on running metre (RM) basis of the water stops provided in position. Rate shall include supplying, cutting, fixing, jointing by vulcanising or any other approved method, wastage, etc. complete.
- 22.3.2 Payment for filler materials in Expansion/Isolation joints shall be made on running metre basis of the joint provided. For boards provided at expansion/isolation joints, the measurement shall be made on square metre basis. Rate shall be inclusive of supply, cutting, fixing, jointing, wastage etc. complete.

22.4 Waterproof Cement Paint

- 22.4.1 Payment for waterproof cement paint as per Cl. 18.0 shall be made separately on Sqm basis.

मानक विनिर्देश
सिविल एवं संरचनात्मक कार्य

STANDARD SPECIFICATION
CIVIL & STRUCTURAL WORKS

संरचनात्मक इस्पात कार्य

STRUCTURAL STEEL WORKS

8	13.05.25	UPDATED & REISSUED	<i>Riya</i> RIYA	<i>Vikram</i> VIKRAM	<i>AS</i> AS	<i>Mandi</i> MN
7	13.01.20	UPDATED & REISSUED	TK	AJS	RS	RK TRIVEDI
6	26.08.14	UPDATED & REISSUED	SP	AS	PKM	S CHANDA
5	18.06.09	REAFFIRMED & REISSUED	AS	PKM	VINAY KUMAR	N. DUARI
4	18.04.00	UPDATED & REISSUED	DPN	RS	SCJ	MI
3	MAY'94	UPDATED & REISSUED	DPN	RS	GPL	A. SONI
Rev. No	Date	Purpose	Prepared by	Checked by	Standards Committee Convenor	Standards Bureau Chairman
Approved by						

Abbreviations:

AFC	:	Approved For Construction
AWS	:	American Welding Society
BIS	:	Bureau of Indian Standards
IS	:	Indian Standards

Structural Standards Committee:

Convenor: Mr. Anurag Sinha

Members: Mr. Virender Goel
Mr. Deepak Agrawal
Ms. Alpana Srivastava
Dr. Sudip Paul
Mr. Charanjit Singh (Projects)
Mr. Indrajit Neog (Construction)
Ms. Papia Mandal
Mr. Vikram Kumar Gupta

CONTENTS

1.0	SCOPE.....	4
2.0	REFERENCE	4
3.0	MATERIALS	4
4.0	FABRICATION DRAWINGS	5
5.0	FABRICATION	7
6.0	MARKING FOR IDENTIFICATION	16
7.0	SHOP ERECTION	16
8.0	INSPECTION & TESTING OF STRUCTURES.....	16
9.0	SHOP PAINTING	16
10.0	PACKING	17
11.0	TRANSPORTATION.....	17
12.0	SITE (FIELD) ERECTION	17
13.0	SAFETY & SECURITY DURING ERECTION	18
14.0	FIELD CONNECTIONS.....	18
15.0	GROUTING	18
16.0	SCHEME AND SEQUENCE OF ERECTION	19
17.0	PAYMENT.....	19
18.0	PAINTING AFTER ERECTION	20
	ANNEXURE-'A'.....	23
	ANNEXURE-'B'.....	25

1.0 SCOPE

This specification describes the information to be included in a Project Specification and also covers the requirements for material, storage, preparation of fabrication drawings, fabrication, assembly, tests/examinations, transportation, erection and painting of all types of bolted and/or welded structural steel works for general construction work. Fabrication of structures shall also include fabricating:

- (a) Built up sections/plate girders made out of rolled section and/or plates.
- (b) Compound sections made out of rolled sections.

2.0 REFERENCES

2.1.1 BIS Codes

IS 800, IS 808, IS 816, IS 819, IS 822, IS 919, IS 1024, IS 1261, IS 1323, IS 1477, IS 1852, IS 2074, IS 7205, IS 7215, IS 7307, IS 7310, IS 7318, IS 9595 and other relevant BIS Codes.

2.1.2 International Standard

AWS D1.1 Structural Welding Code - Steel

2.2 EIL Specifications

6-68-0002- Materials

6-79-0020 (or relevant Job Specification) – Surface preparation & protective coating

2.3 In case of conflict between the clauses mentioned in this specification and those in the Indian Standards, this specification shall govern. Any special provision as shown or noted on the design drawings or any project specific specification specified elsewhere shall govern over the provisions of this specification.

3.0 MATERIALS

3.1 General

All materials shall conform to their respective specifications given in EIL Specification no. 6-68-0002. The use of equivalent or alternative materials shall be permitted only in very special cases and for all such cases prior written approval of the Engineer-in-Charge shall be obtained.

3.2 Receipt & Storing of Materials

3.2.1 Each section shall be marked for identification and each lot shall be accompanied by manufacturer's quality certificate, chemical analysis and mechanical characteristics.

3.2.2 All sections shall be checked, sorted out and arranged by grade and quality in the store. Any instruction given by the Engineer-in-Charge in this respect shall be strictly followed.

3.2.3 All material shall be free from surface defects such as pitting, cracks, laminations, twists etc. Defective material shall not be used and all such rejected material shall be immediately removed from the store/site. The decision of the Engineer-in-Charge in this regard shall be final and binding.

- 3.2.4 Welding wires and electrodes (packed in their original cartons) shall be stored separately by quality and lots inside a dry and enclosed room in compliance with IS 9595 and as per the instructions given by the Engineer-in-Charge. Electrodes shall be kept perfectly dry to ensure satisfactory operation and weld metal soundness.
- 3.2.5 Each lot of electrodes, bolts, nuts etc. shall be accompanied by manufacturer's quality/test certificates.
- 3.2.6 All bolts (including nuts & washers) shall be checked, sorted out and arranged diameter-wise by grade and quality in the store.

3.3 Material Tests

- 3.3.1 The Contractor shall submit manufacturers' quality certificates for all the materials supplied by him. In case, quality certificates are not available or are incomplete or when material quality differs from standard specifications, such materials shall not be used in the construction. However, the Contractor shall get all appropriate tests conducted in approved test houses for such materials as directed by the Engineer-in-Charge, at no extra cost, and submit the same to Engineer-in-Charge for his approval. The Engineer-in-Charge may approve the use of such materials entirely at his discretion.
- 3.3.2 The Contractor shall ensure that all materials brought to site are duly approved by the Engineer-in-Charge. Rejected materials shall not be used and shall be removed from site forthwith. Any material of doubtful quality for which specific tests are to be carried out as per the instruction of the Engineer-in-Charge shall be separately stacked and properly identified and shall not be used. These shall be removed from site forthwith.

4.0 FABRICATION DRAWINGS

- 4.1 Fabrication and erection drawings shall be prepared by the Contractor on the basis of "Approved for Construction" (AFC) design drawings, EIL Standards issued to the Contractor. These drawings shall be prepared by Contractor or by an agency engaged by the contractor using TEKLA or AUTODESK Advance Steel or equivalent 3D Modeling software and approved by the Engineer-in-Charge.
- 4.2 Fabrication and erection drawings shall be thoroughly checked, stamped "Approved for Construction" and signed by the Contractor's own responsible Engineer irrespective of the fact that such drawings are prepared by the Contractor or his approved agency, to ensure accuracy and correctness of the drawings. Unchecked and unsigned drawings shall not be used for the purpose of proceeding with the work. The Contractor shall proceed with the fabrication and erection work only after thoroughly satisfying himself in this regard.
- 4.3 All fabrication and erection drawings shall be issued for construction by the Contractor directly to his work- site. Six copies of such drawings shall simultaneously be submitted to the Engineer-in-Charge who may check/ review some or all such drawings at his sole discretion and offer his comments for incorporation in these drawings by the Contractor.

However, the Contractor shall not proceed with the fabrication of such structures whose fabrication drawings are required to be reviewed before taking up the fabrication work as noted on "Approved for Construction (AFC)" design drawings issued to the Contractor or as conveyed by the Engineer-in-Charge. The fabrication of such structures shall be done only as per the reviewed fabrication drawings.

The review of such drawings by EIL shall be restricted to the checking of the following only:

- i) Structural layout, orientation and elevation of structures/members.
- ii) Sizes of members.
- iii) Critical joint details.

4.4 Fabrication drawings shall be drawn to scale and shall convey the information clearly and adequately. Following information shall be furnished on such drawings:

- i) Reference to design drawing number (along with revision number) based on which fabrication drawing has been prepared.
- ii) Structural layout, elevations & sections (with distinct erection marking of all members).
- iii) Framing plans, member sizes, orientation and elevations.
- iv) Layout and detailing of rain water pipes and gutters showing all necessary levels, connections and provisions wherever required.
- v) Detailing of shop/field joints, connections, splices, for required strength and erection.
- vi) Location, type, size and dimensions of welds and bolts.
- vii) Shapes and sizes of edge preparation for welding.
- viii) Details of shop and field joints/welds.
- ix) Bill of materials/D.O.D. Lists.
- x) Quality of structural steel, plates etc., welding electrodes, bolts, nuts and washers to be used.
- xi) Erection assemblies identifying all transportable parts and sub-assemblies with special erection instructions, if required.
- xii) Method of erection and special precautions to be taken during erection as required.
- xiii) Details of holes and fittings in components necessary for safe lifting and erection purpose.

4.5 The Contractor shall additionally ensure accuracy of the following and shall be solely responsible for the same:

- i) Provision for erection and erection clearances.
- ii) Marking of members
- iii) Cut length of members
- iv) Matching of joints and holes.

- v) Provision kept in the members for other interconnected members.
- vi) Bill of materials/D.O.D. Lists.
- 4.6 Connections, splices and other details where not shown on the design drawings shall be suitably designed and shown on the fabrication drawings based on good engineering practice developing full member strength. **Design calculations for such connections/splices shall be submitted to the Engineer-in-Charge along with the fabrication drawings.**
- 4.7 Any substitution or change in section shall be allowed only when prior written approval of the Engineer-in-Charge has been obtained. Fabrication drawings shall be updated incorporating all such substitutions/changes by the Contractor at no extra cost to the Owner.
- 4.8 In case during execution of the work, the Engineer-in-Charge on review of drawings considers any modifications/ substitutions necessary to meet the design parameters/ good engineering practice, these shall be brought to the notice of the Contractor who shall incorporate the same in the drawings and works without any extra cost to the owner. The Contractor will be totally responsible for the correctness of the detailed fabrication drawings and execution of the work.
- 4.9 Contractor shall incorporate all the revisions made in the design drawings during the course of execution of work in his fabrication drawings, and resubmit the drawings at no extra cost to the Owner. All fabrication shall be carried out only as per the latest AFC design drawings and corresponding fabrication drawings.
- 4.10 The Contractor shall supply two prints each of the final/as built drawings along with their native soft file to Engineer-in-Charge for reference and record. The rates quoted shall include for the same.
- 5.0 FABRICATION**
- 5.1 General**
- 5.1.1 Fabrication of structures shall be done strictly as per "Approved for Construction" fabrication drawings (prepared by the Contractor based on the latest design drawings) and in accordance with IS 800, 9595 & other relevant BIS Codes.
- 5.1.2 Prior to commencement of structural fabrication, undulations in the fabrication yard, if any, shall be removed and area levelled and paved by the Contractor.
- 5.1.3 Any defective material used in the work shall be replaced by the Contractor at his own expense. Necessary care and precautions shall be taken so as not to cause any damage to the structure during any such removal and replacement.
- 5.1.4 Any faulty fabrication pointed out at any stage of work by the Engineer-in-Charge, shall be made good or replaced by the Contractor at his own cost.
- 5.1.5 Tolerances for fabrication of steel structures shall be as per IS 7215.

5.2 Fabrication Procedure

5.2.1 Straightening & Bending

5.2.1.1 All materials shall be straight and, if necessary, before being worked shall be straightened and/or flattened (unless required to be of curvilinear form) and shall be free from twists.

5.2.1.2 Bending of rolled sections and plates shall be done by cold process to shape/s as shown on drawings.

5.2.1.3 After completion of bending or straightening, welds within the area of bending or straightening shall be thoroughly visually inspected. Nondestructive tests required to be carried out for such locations shall be done only after straightening or bending activity.

5.2.2 Clearances

The erection clearance for cleated ends of members shall be not greater than 2mm at each end. The erection clearance at ends of beams without web cleats and end plates shall be not more than 3mm at each end but where for practical reasons, greater clearance is necessary, suitably designed seatings approved by the Engineer-in-Charge shall be provided.

5.2.3 Cutting

5.2.3.1 Prior to cutting, all members shall be properly marked showing the requisite cut length/width, connection provisions e.g. location and dimensions of holes, welds, cleats etc. Marking for cutting shall be done judiciously so as to avoid wastages or unnecessary joints as far as practicable. Marking shall be done by placing the members on horizontal supports/pads in order to ensure accuracy. Marking accuracy shall be limited to + 1mm.

5.2.3.2 Cutting may be affected by shearing, cropping or sawing. Gas cutting by mechanically controlled torch shall be permitted for mild steel. Hand flame cutting may be permitted subject to the approval of the Engineer-in-Charge.

5.2.3.3 Except where the material is subsequently joined by welding, no loads shall be transmitted into metal through a gas cut surface.

5.2.3.4 Shearing, cropping and gas cutting shall be clean, square, free from any distortion & burrs, and should the Engineer-in-Charge find it necessary, the edges shall be ground afterwards, to make the same straight and uniform at no extra cost to the Owner.

5.2.4 Making Holes

5.2.4.1 Holes for bolts shall not be formed by gas cutting process.

5.2.4.2 Holes through more than one thickness of material of members such as compound stanchions and girder flanges shall, where possible, be drilled after the members are assembled and tightly clamped/bolted together. Punching may be permitted before assembly, provided the thickness of metal is less than 16mm and the holes are punched 3mm less in diameter than the required size and reamed, after assembly, to the full diameter. Punching shall not be adopted for dynamically loaded structures.

5.2.4.3 Holes may be drilled in one operation through two or more separable parts and burrs removed from each part after drilling.

- 5.2.4.4 Holes in connecting angles and plates, other than splices, also in roof members and light framing, may be punched full size through material not over 12mm thick, except where required for close tolerance bolts or barrel bolts.
- 5.2.4.5 All matching holes for black bolts shall register with each other so that a gauge of 2mm less in diameter than the diameter of hole shall pass freely through the assembled members in the direction at right angle to such members. Finished holes shall be not more than 2mm in diameter larger than the diameter of the black bolt passing through them, unless otherwise specified by the Engineer- in-Charge.
- 5.2.4.6 Holes for turned and fitted bolts shall be drilled to a diameter equal to the nominal diameter of the shank or barrel subject to H8 tolerance specified in IS 919. Parts to be connected with close tolerance or barrel bolts shall be firmly held together by tacking bolts or clamps and the holes drilled through all the thicknesses in one operation and subsequently reamed to size. Holes not drilled through all the thicknesses in one operation shall be drilled to a smaller size and reamed out after assembly. Where this is not possible, the parts shall be drilled and reamed separately. *
- 5.2.4.7 To facilitate grouting, holes shall be provided in column bases or seating plates exceeding 300mm in width for the escape of air.
- 5.2.4.8 To avoid accumulation of water in gusseted column bases of laced, battened or box type stanchions, suitable reverse U-type holes shall be provided at the junction of base plate and column section in the vertical gussets for draining out of any water.
- 5.2.4.9 Slotted holes shall be punched or formed by drilling two holes and completed by cutting.

5.2.5 Assembly

The component parts shall be assembled and aligned in such a manner that they are neither twisted nor otherwise damaged, and shall be so prepared that the required camber, if any, is provided. Proper clamps, clips, jigs and other fasteners (bolts and welds) shall be placed in a balanced pattern to avoid any distortion in the members and to ensure their correct positioning (i.e. angles, axes, nodes etc.). Any force fitting, pulling/stretching of members to join them shall be avoided. Proper care shall be taken for welding shrinkage & distortion so as to attain the finished dimensions of the structure shown on the drawings.

5.2.6 Welding

5.2.6.1 General

- All joints shall be welded unless noted otherwise on the design drawings.
- Welding shall be in accordance with IS 816, IS 819, IS 1024, IS 1261, IS 1323 and IS 9595 as appropriate.
- The Contractor shall make necessary arrangement for providing sufficient number of welding sets of the required capacity, all consumables, cutting and grinding equipment with requisite accessories/ auxiliaries, equipment & materials required for carrying out various tests such as dye penetration, magnetic particle, ultrasonic etc.
- Adequate protection against rain, dust, snow & strong winds shall be provided to the welding personnel and the structural members during welding operation. In the absence of such a protection no welding shall be carried out.

- e) It shall be the responsibility of the Contractor to ensure that all welding is carried out in accordance with the terms of this specification and relevant BIS codes. The Contractor shall provide all the supervision to fulfil this requirement.

5.2.6.2 Preparation of Member for Welding

a) Edge Preparation

Edge preparation/bevelling of fusion faces for welding shall be done strictly as per the dimensions shown in the drawings. In case, the same are not indicated, edges shall be prepared (depending on the type of weld indicated in the drawing) as per the details given in IS 9595. Bevelling of fusion faces shall be got checked and approved by the Engineer- in-Charge. The tolerances on limits of gap, root face & included angle shall be as stipulated in IS 9595.

b) Cleaning

Welding edges and the adjacent areas of the members (extending upto 20mm) shall be thoroughly cleaned of all oil, grease, scale and rust and made completely dry. Gaps between the members to be welded shall be kept free from all foreign matter.

c) Preheating

Preheating of members, shall be carried out as per IS 9595 when the base metal temperature is below the requisite temperature for the welding process being used. Preheating shall be done in such a manner that the parts, on which the weld metal is being deposited, are above the specified minimum temperature for a distance of not less than 75mm on each side of the weld line. The temperature shall be measured on the face opposite to that being heated. However, when there is access to only one face, the heat source shall be removed to allow for temperature equalization (1 minute for each 25mm of plate thickness) before measuring the temperature.

d) Grinding

- i) Column splices & butt joints of struts and compression members (depending on contact for load transmission) shall be accurately ground and close-butted over the whole section with a tolerance not exceeding 0.2mm locally at any place. In column caps & bases, the ends of shafts together with the attached gussets, angles, channels etc., shall be accurately ground so that the parts connected butt over minimum 90% surface of contact. In case of connecting angles or channels, care shall be taken so that these are fixed with such accuracy that they are not reduced in thickness by grinding by more than 2mm.
- ii) Ends of all bearing stiffeners shall be ground to fit tightly at both top and bottom. Similarly bottom of the knife edge supports along with the top surface of column brackets shall be accurately ground to provide effective bearing with a tolerance not exceeding 0.2mm locally at any place.
- iii) Slab bases and caps shall be accurately ground over the bearing surfaces and shall have effective contact with the ends of stanchions. Bearing faces which are to be grouted direct to foundations need not be ground if such faces are true & parallel to the upper faces.
- iv) Tack welding shall be thoroughly removed by grinding or gouging such that subsequent welding shall be done properly.

5.2.6.3 Welding Processes

Welding of various materials under this specification shall be carried out using one or more of the following processes.

- Manual Metal Arc Welding Process (MMAW)
- Submerge Arc Welding Process (SAW)
- Gas Metal Arc Welding Process (GMAW)
- Flux Cored Arc Welding Process (FCAW)

The welding procedure adopted and consumables used shall be specifically approved by the Engineer-in-Charge. A combination of different welding processes or a combination of electrodes of different classes/makes may be employed for a particular joint only after qualifying the welding procedures to be adopted and obtaining the written approval of the Engineer-in-Charge.

5.2.6.4 Approval & Testing of Welders

The Contractor shall satisfy the Engineer-in-Charge that the welders are suitable for the work upon which they will be employed. For this purpose, the welders shall have satisfied the relevant requirements of IS 7318 or AWS D1.1. If the welders will be working to approved welding procedures, they shall have satisfied the relevant requirements of IS 7310 or AWS D1.1.

Adequate means of identification shall be provided to enable each weld to be traced to the welder by whom it was made. The Contractor shall intimate the Engineer-in-Charge sufficiently in advance, the commencement of tests, to enable him to be present to witness the same.

5.2.6.5 Approval & Testing of Welding Procedures

The Contractor shall carry out procedure tests in accordance with IS 7307 or AWS D1.1 to demonstrate by means of a specimen weld of adequate length on steel representative of that to be used, that he can make welds with the welding procedure to be used for the work to the complete satisfaction of the Engineer-in-Charge. The test weld shall include weld details from the actual construction and it shall be welded in a manner simulating the most unfavourable instances of fit-up, electrode condition etc., which are anticipated to occur on the particular fabrication. Where material analysis is available, the welding procedure shall be carried out on material with the highest carbon equivalent value.

After welding, but before the relevant tests given in IS 7307 or AWS D1.1 are carried out, the test weld shall be held as long as possible at room temperature, but, in any case not less than 72 hours, and shall then be examined for cracking. The examination procedure shall be sufficiently rigorous to be capable of revealing significant defects in both parent metal and weld metal.

After establishing the welding method, the Contractor shall finally submit to the Engineer-in-Charge for his approval the welding procedure specification in standard format given in IS 9595 before starting the fabrication.

5.2.6.6 Sequence of Welding

- a) As far as practicable, all welds shall be made in a sequence that will balance the applied heat of welding while the welding progresses.
- b) The direction of the general progression in welding on a member shall be from points where the parts are relatively fixed in position with respect to each other towards points where they have a greater relative freedom of movement.
- c) All splices in each component part of a cover-plated beam or built up member shall be made before the component part is welded to other component parts of the member.
- d) Joints expected to have significant shrinkage shall be welded before joints expected to have lesser shrinkage.
- e) Welding shall be carried continuously to completion with correct number of runs.
- f) The Contractor shall choose the welding sequence after carefully studying each case such as to minimize distortion and shrinkage & submit the same to the Engineer-in-Charge for comments and approval.

5.2.6.7 Welding Technique

- a) After the fusion faces are carefully aligned and set with proper gaps, the root pass of butt joints shall be executed properly so as to achieve full penetration with complete fusion of the root edges.
- b) On completion of each run, all slag and spatters shall be removed and the weld and the adjacent base metal shall be cleaned by wire brushing and light chipping. Visible defects such as cracks, cavities and other deposition faults, if any, shall be removed to sound metal before depositing subsequent run of weld.
- c) All full penetration butt welds shall be completed by chipping/gouging to sound metal and then depositing a sealing run of weld metal on the back of the joints. Where butt welding is practicable from one side only, suitable backing steel strip shall be used and joint shall be arranged in such a way as to ensure that complete fusion of all the parts is readily obtained.
- d) While welding is in progress care shall be taken to avoid any kind of movement of the components, shocks, vibrations to prevent occurrences of weld cracks.
- e) Any deviation desired from the recommended welding technique and electrodes shall be adopted only after obtaining written approval of the Engineer-in-Charge.

5.2.6.8 Inspection & Testing of Welds

The method of inspection shall be according to IS 822 and extent of inspection and testing shall be in accordance with the relevant applicable standard or, in the absence of such a standard, as specified by the Engineer-in-Charge. Welds shall not be painted or otherwise obscured until they have been inspected, approved and accepted.

The Engineer-in-Charge or his representative shall have access to the Contractor's work at all reasonable times and the Contractor shall provide him with all facilities necessary for

inspection during all stages of fabrication and erection with, but not limited to, the following objectives.

- i) To check the conformity with the relevant standards and suitability of various welding equipments and their performance.
- ii) To witness/approve the welding procedure qualification.
- iii) To witness/approve the welders performance qualification.
- iv) To check whether shop/field welding being executed is in conformity with the relevant specifications and codes of practice.

Inspection and testing of all fabricated structures shall be carried out by the Contractor by any, or, a combination of all the following methods as directed by the Engineer-in-Charge and no separate payment shall be made, unless otherwise mentioned, for inspection and testing of welds/fabricated structures:

A. Visual Inspection

All finished welds (i.e. 100 percent) shall be visually inspected for identification of the following types of weld defects & faults.

- a) Weld defects occurring at the surface such as blow holes, exposed porosity, unfused welds etc.
- b) Surface cracks in the weld metal or in the parent metal adjacent to it.
- c) Damages to the parent metal such as undercuts, burning, overheating etc.
- d) Profile defects such as excessive convexity or concavity, overlapping, unequal leg lengths, excessive reinforcement, incompletely filled grooves, excessive penetration beads, root grooves etc.
- e) Distortion due to welding i.e., local shrinkage, camber, bowing, twisting, rotation, wariness etc.
- f) Linear eccentric, angular and rotational misalignment of parts.
- g) Dimensional errors.

B. Mechanical Tests

The mechanical testing (such as tensile load tests, bend tests, impact tests etc.) shall be done in accordance with the relevant standards and as per the instructions of the Engineer-in-Charge.

C. Magnetic Particle/Dye Penetration/Ultrasonic Examination

The examination shall be done at random as directed by the Engineer-in-Charge. Whenever such tests are directed, the tests shall be carried out on joints chosen by him. The tests shall be carried out by employing approved testing procedure in accordance with IS 822.

D. Radiographic Examination

Radiographic examination shall be carried out only in special cases for random joints as directed by the Engineer-in-Charge. The Contractor shall be paid extra for such examination except for penalty radiographic tests for which the cost shall be borne by him. The Contractor shall make necessary arrangement at his own expense for providing the radiographic equipment, films and all other necessary materials required for carrying out the examination. The tests shall be carried in the presence of the Engineer-in-Charge by employing approved testing procedure in accordance with IS 822. The Contractor shall fulfill all the statutory safety requirements while handling X-ray and Gamma-ray equipment and provide the Engineer-in-Charge all the necessary facilities at site such as dark room, film viewer etc., to enable him to examine the radiographs.

5.2.6.9 Repair of Faulty Welds

No repair of defective welds shall be carried out without proper permission of the Engineer-in-Charge and his approval for the corrective procedure.

Welds not complying with the acceptance requirements (as specified by BIS Codes & the Engineer-in-Charge), as revealed during inspection & testing of welds or erection or in-situ condition, shall be corrected either by removing & replacing or as follows:

- | | |
|--|--|
| a) Excessive convexity | - Reduced to size by removal of excess weld metal. |
| b) Shrinkage cracks, cracks in
in parent plates and craters | - Defective portions removed down to sound metal
and re-welded. |
| c) Under cutting. | - Additional weld metal deposited. |
| d) Improperly fitted/
misaligned parts. | - Welding cut & edges suitably prepared and parts. |
| e) Members distorted
by the heat of welding | - Member straightened by mechanical means or
careful application of limited amount of heat,
temperature of such area not to exceed 650 degree
Centigrade (dull red heat). |

In removing defective parts of a weld, gouging, chipping, oxygen cutting or grinding shall not extend into the parent metal to any substantial amount beyond the depth of weld penetration, unless cracks or other defects exist in the parent metal. The weld or parent metal shall not be undercut in chipping, grinding, gouging or oxygen cutting.

Any fabricated structure or its component which, in the opinion of Engineer-in-Charge, is defective and/or beyond any corrective action shall be removed forthwith from the site as instructed by the Engineer-in-Charge without any extra claim. The owner reserves the right to recover any compensation due to any loss arising out of such rejections.

5.2.7 Bolting

5.2.7.1 All bolts shall be provided such that no part of the threaded portion of the bolts is within the thickness of the parts bolted together. Washers of suitable thickness shall be used under the nuts to avoid any threaded portion of the bolt being within the thickness of parts bolted together.

5.2.7.2 The threaded portion of each bolt shall project through the nut at least one thread.

- 5.2.7.3 Flat washers shall be circular and of suitable thickness. However, where bolt heads/nuts bear upon the bevelled surfaces, they shall be provided with square tapered washers of suitable thickness to afford a seating square with the axis of the bolt.
- 5.2.7.4 Different bolt grades of the same diameter shall not be used in the same structure, except if agreed otherwise by the Engineer-in-Charge.
- 5.2.7.5 Bearing type bolts shall be used (unless noted otherwise) and tightened firmly by available means.
- 5.2.8 **Splicing**
- 5.2.8.1 Splicing of built up/compound/latticed sections shall be done in such a fashion that each component of the section is joined in a staggered manner.
- 5.2.8.2 Where no butt weld is used for splicing, the meeting ends of two pieces of joist/channel/built up section shall be ground flush for bearing on each other and suitable flange and web splice plates shall be designed and provided for the full strength of the flange/ web of the section and welds designed accordingly.
- 5.2.8.3 Where full strength butt weld is used for splicing (after proper edge preparation of the web and flange plates) of members fabricated out of joist/ channel/ angles/ built up section, additional flange and web plates shall be provided, over and above the full strength butt welds, to have 40% strength of the flange and web.
- 5.2.8.4 Where a cover plate is used over a joist/channel section the splicing of the cover plate and channel/joist sections shall be staggered by minimum 500mm. Extra splice plate shall be used for the cover plate and joist/channel section as per clause 5.2.8.2 or 5.2.8.3.
- 5.2.8.5 Prior approval shall be obtained by the Contractor for locations of splices where not shown on design drawings. For members upto a length of 7m, generally no splice shall be allowed but in exceptional cases one splice shall be allowed at approved location. Maximum two numbers of splices shall be allowed for members exceeding this length.
- 5.2.9 **Machining & Grinding**
- 5.2.9.1 All slab bases and slab caps shall be accurately machined over the bearing surfaces and shall be in effective contact with the ends of column sections (shafts).
- 5.2.9.2 For slab bases and slab caps, ends of column shafts shall be accurately machined. However, for gusseted bases and caps, the column shafts shall be ground flush for effective contact with parts connected together.
- 5.2.9.3 Gusseted bases and caps shall be ground flush for effective contact with ends of column sections.
- 5.2.9.4 End of all bearing stiffeners shall be machined or ground to fit tightly at top and bottom without any air gap.
- 5.2.9.5 While machining or grinding care shall be taken so that the length or thickness of any part does not get reduced by more than 2.0mm.
- 5.2.9.6 For all machining or grinding works for gusseted base and cap plates, the clearance between the parts joined shall not exceed 0.2mm at any location.

6.0 MARKING FOR IDENTIFICATION

- 6.1 Each component shall be distinctly marked (with paint) before delivery in accordance with the marking diagrams and shall bear such other marks as will facilitate erection. Components which are identical in all respects may have the same erection mark.
- 6.2 For small members which are delivered in bundles or crates, the required marking shall be done on small metal tags securely tied to the bundle.

7.0 SHOP ERECTION

The steel work shall be temporarily shop erected complete or as directed by the Engineer-in-Charge, so that the accuracy of fit may be checked before despatch.

8.0 INSPECTION & TESTING OF STRUCTURES

- 8.1 The Engineer-in-Charge (or his authorised representative) shall have free access at all times to those parts of the Contractor's works which are concerned with the fabrication of the steel work and shall be provided with all reasonable facilities for satisfying himself that the fabrication is being undertaken in accordance with the provisions of these specifications & other relevant BIS Codes.
- 8.2 Should any structure or part of a structure be found not to comply with any of the provisions of this specification (or relevant BIS Codes as referred to), it shall be liable to rejection. No structure or part of the structure, once rejected shall be resubmitted for inspection, exception cases where the Engineer-in-Charge or his authorised representative considers the defect as rectifiable.
- 8.3 Defects which may appear during/after fabrication/ erection shall be made good only with the consent of the Engineer-in-Charge and procedure laid down by him.
- 8.4 All necessary gauges and templates shall be supplied free to the Engineer-in-Charge by the Contractor whenever asked for during inspection. The Engineer-in-Charge, may at his discretion, check the test results obtained at the Contractor's works by independent tests at a test house, and the cost of such tests shall be borne by the Contractor.

9.0 SHOP PAINTING

- 9.1 All components and members of steel work shall be given one shop coat of primer, as specified in the tender, immediately after the surfaces have been properly prepared (i.e. degreased, derusted, descaled & cleaned) in accordance with the job specification or 6-79-0020, as applicable.

The primer coat shall be applied over completely dry surfaces (using brushes of good quality) in a manner so as to ensure a continuous and uniform film without "holidaying". Special care shall be taken to cover all the crevices, corners, edges etc. However, in areas which are difficult to reach by brushing, daubers/mops shall be used by dipping the same in paint and then pulling/ pushing them through the narrow spaces. The primer coat shall be air dried and shall have the thickness as per EIL Specification no. 6-79-0020 or the relevant job specification.

- 9.2 Surfaces which are inaccessible after shop assembly, shall receive the full specified protective treatment before assembly (this shall not apply to the interior of sealed hollow sections).
- 9.3 Steel surfaces shall not be painted within a suitable distance of any edges to be welded if the paint specified would be harmful to welders or impair the quality of the welds.
- 9.4 Welds and adjacent parent metal shall not be painted prior to deslagging, inspection and approval by the Engineer-in-Charge.
- 9.5 Parts to be encased in concrete shall have only one coat of primer and shall not be painted after erection.

10.0 PACKING

- 10.1 All items shall be suitably packed in case these are to be despatched from the fabrication shop to the actual site of erection so as to protect them from any damage/distortion or falling during transit. Where necessary, slender projecting parts shall be temporarily braced to avoid warping during transportation.
- 10.2 Small parts such as gussets, cleats etc., shall be securely wired on to their respective main members.
- 10.3 Bolts, nuts washers etc. shall be packed in crates.

11.0 TRANSPORTATION

Loading and transportation shall be done in compliance with transportation rules. In case, certain parts can not be transported in the lengths stipulated on the drawings, the position details of such additional splice joints shall be got approved by the Engineer-in-Charge.

12.0 SITE (FIELD) ERECTION

12.1 Plant & Equipment

The suitability and capacity of all plant and equipment used shall be to the complete satisfaction of the Engineer-in-Charge.

12.2 Storing & Handling

All steel work shall be so stored and handled at site so that the members are not subjected to surface abrasion, excessive stresses and any damage.

12.3 Setting Out

Prior to setting out of the steel work, the Contractor shall get himself satisfied about the correctness of levels, alignment, location of existing concrete pedestals/columns/brackets and holding down bolts/pockets provided therein. Any minor modification in the same including chipping, cutting and making good, adjusting the anchor bolts etc., if necessary, shall be carried out by the Contractor at his own expense. The positioning and levelling of all steel work including plumbing of columns and placing of every part of the structure with

accuracy shall be in accordance with the drawings and to the complete satisfaction of the Engineer-in-Charge.

12.4 Tolerances

Tolerances for erection of steel structures shall be as per Annexure 'A'

13.0 SAFETY & SECURITY DURING ERECTION

13.1 The contractor shall comply with IS 7205 for necessary safety and adhere to safe erection practices and guard against hazardous as well as unsafe working conditions during all stages of erection.

13.2 During erection, the steel work shall be securely bolted or otherwise fastened and when necessary, temporarily braced/guyed to provide for all loads to be carried by the structure during erection till the completion, including those due to the wind, erection equipment & its operation etc. at no extra cost to the owner. For the purpose of guying, the Contractor shall not use other structure in the vicinity without prior written permission of the Engineer-in-Charge.

13.3 No permanent bolting or welding shall be done until proper alignment has been achieved.

13.4 Proper access, platform and safety arrangement shall be provided for working and inspection, (at no extra cost to the owner) whenever required.

14.0 FIELD CONNECTIONS

14.1 Field Bolting

Field bolting shall be carried out with the same care as required for shop bolting.

14.2 Field Welding

All field assembly and welding shall be executed in accordance with the requirements for shop assembly and welding. Holes for all erection bolts - where removed after final erection shall be plugged by welding. Alternatively, erection bolts may be left and secured.

15.0 GROUTING

15.1 Prior to positioning of structural columns/girders/ trusses over the concrete pedestals/columns/brackets, all laitance & loose material shall be removed by wire brushing & chipping. The bearing concrete surfaces shall be sufficiently levelled, hacked with flat chisels to make them rough, cleaned (using compressed air) and made thoroughly wet. All pockets for anchor bolts shall also be similarly cleaned and any excess water removed. Thereafter, the structural member shall be erected, aligned & plumbed maintaining the base plates/shoe plates at the levels shown in the drawings, with necessary shims/pack plates/wedges.

15.2 After final alignment and plumbing of the structure, the forms shall be constructed around and joints made tight to prevent leakage. Grouting (under the base plates/shoe plates including grouting of sleeves & pockets) shall be done with non-shrink grout having compressive strength (28 days) not less than 40N/sq.mm. Non shrink grout shall be of free

flow premix type and of approved quality and make. It shall be mixed with water in proportion as specified by the manufacturer. Ordinary 1:2 cement/sand mortar grout shall be used only for small, isolated structures e.g. operating platforms not supporting any equipment, pipe supports, crossovers, stairs & ladders. The thickness of grout shall be as shown on the drawings. In case, not mentioned grout thickness shall not be less than 25mm nor more than 50mm in any case.

- 15.3 The grout mixture shall be poured continuously (without any interruption till completion) by grouting pumps from one side of the base plate and spread uniformly with flexible steel strips and rammed with rods, till the space is filled solidly and the grout mixture carried to the other side of the base plate.
- 15.4 The grout mixture shall be allowed to harden for a period as decided by the Engineer-in-Charge. At the end of this period, the shims/wedges/pack plates may be removed and anchor bolts tightened uniformly. The alignment of the structure shall now be rechecked and if found correct, the voids left by the removal of shims/wedges/pack plates (if removed) must be filled up with a similar mixture of grout. In case after checking, serious misalignment is indicated, the grout shall be removed completely and fresh grouting done after making appropriate correction of alignment.

16.0 SCHEME AND SEQUENCE OF ERECTION

The Contractor shall furnish the detailed scheme and sequence of erection to match with the project schedule and get the same approved by the Engineer-in-Charge. All necessary co-ordination and synchronization shall be done with the Civil contractor where Civil works are not included in the scope of structural contractor at no extra cost so as to match with the project schedule.

17.0 PAYMENT

This clause shall apply to Item Rate tender only.

- 17.1 Payment for structural steel works shall be made on the basis of admissible weight in metric tons (determined as described in clause 17.2 and 17.3) of the structure accepted by the Engineer-in-Charge. The rate shall include supplying (as per supply conditions given in the Tender) fabricating, erecting in position (at all levels & locations), testing/examining (excluding radiography only) of bolted and/or welded structural steel works of all types (including all built up/compound sections made out of rolled sections and/or plates) including all handling, transporting, storing, straightening if required, cutting, edge preparation, preheating, bolting and welding of joints (including sealing the joints of box sections with continuous welding), finishing edges by grinding/machining as shown, fixing in line & level with temporary staging & bracing and removal of the same after erection, grouting with non-shrink/ordinary grout as specified, preparation of fabrication & erection drawings, & erection schedule and getting them reviewed, preparation and submission of as built drawings, preparing the surfaces for painting, and applying the primer as specified after fabrication, return of surplus materials to owner's stores and material reconciliation in the case of materials supplied by the owner as per relevant contract conditions etc. all complete for all the operations mentioned in the foregoing clauses.
- 17.2 The weight for payment shall be determined from the fabrication drawings and respective bill of materials prepared by the Contractor. The bill of materials shall be checked and approved by the Engineer-in-Charge before making the payment. The Contractor shall prepare full scale template in order to supplement/verify the actual cutting dimensions

where so directed by the Engineer-in-Charge. The weight shall be calculated on the basis of BIS Hand Book wherever applicable. In case sections used are different from BIS sections, then Manufacturers' Hand Book shall be adopted. No allowance in weight shall be made for rolling tolerances.

- 17.3 Welds, bolts, nuts, washers, shims, pack plates, wedges, grout and shop painting shall not be separately measured. The quoted rate shall be deemed to include the same.
- 17.4 The rate shall include all expenses related to safety & security arrangements during erection and all plants & tools required for fabrication, transportation & erection.

18.0 PAINTING AFTER ERECTION

18.1 General

18.1.1 The scope of painting after erection shall be at the sole discretion of the Engineer-in-Charge and the Contractor shall obtain written instruction in this regard sufficiently prior to taking up any procurement of paint and execution of painting work after erection of steel structures.

18.1.2 The Contractor shall carry out the painting work in all respects with the best quality of approved materials (conforming to relevant EIL Specification no. 6-79-0020 or the job specification, as applicable) and workmanship in accordance with the best engineering practice. The Contractor shall furnish characteristics of paints (to be used) indicating the suitability for the required service conditions. The paint manufacturer's instructions supplemented by Engineer-in-Charge's direction, if any, shall be followed at all times. Particular attention shall be paid to the following:

- Proper storage to avoid exposure & extremes of temperature.
- surface preparation prior to painting.
- Mixing & thinning.
- Application of paint and the recommended limit on time intervals between consecutive coats.

18.1.3 Painting shall not be done in frost or foggy weather, or when humidity is such as to cause condensation on the surfaces to be painted.

18.1.4 Surface which shall be inaccessible after site assembly shall receive the full specified protective treatment before assembly.

18.1.5 Primers & finish coat paints shall be from the same manufacturer in order to ensure compatibility. Painting colour code shall be as per Annexure-'B' or the job specification.

18.2 Rub Down & Primer Application

The shop coated surfaces shall be rubbed down thoroughly with emery/abrasive paper to remove dust, rust, other foreign matters and degreased, if required, in accordance with EIL specification no. 6-79-0020 or the job specification, as applicable, cleaned with warm fresh water and air dried. The portions, from where the shop coat has peeled off, shall be touched up and allowed to dry.

Primer coat as per EIL specification no. 6-79-0029 or the job specification, as applicable, shall be applied by brushing/ spraying over the shop coat in a manner so as to ensure a continuous and uniform film throughout. Special care shall be taken to cover all the crevices, corners, edges etc. The final primer coat shall be air dried and shall have a

minimum film thickness as per EIL Specification no. 6-79-0020 or job specification after drying, as applicable.

In case different cleaning procedure & primer specifications are specified in the drawing/Tender, the same shall be adopted.

18.3 Final Paint Application

After the primer is hard dry, the surfaces shall be dusted off and the paint as per EIL specification no. 6-79-0020 or the job specification, as specified, shall be applied by brushing/spraying so that a film free from "holidaying" is obtained. The colour & shade of first coat of paint shall be slightly lighter than the second coat in order to identify the application of each coat. The second coat of paint shall be applied after the first coat is hard dry. The minimum thickness of each film shall be 20 microns ($\pm 10\%$ tolerance) after drying.

In case a different type of paint & painting procedure are specified in the drawing/tender, the same shall be adopted.

18.4 Inspection & Testing of Painting Works

18.4.1 All painting materials including primers & thinners brought to site by the Contractor for application shall be procured directly from reputed and approved manufacturers and shall be accompanied by manufacturer's test certificates. Paint formulations without certificates shall not be accepted.

18.4.2 The Engineer-in-Charge at his discretion may call for additional tests for paint formulations. The Contractor shall arrange to have such tests performance including batch wise test of wet paints for physical & chemical analysis. All costs shall be borne by the Contractor.

18.4.3 The painting work shall be subject to inspection by the Engineer-in-Charge at all times. In particular, the stage inspection will be performed and Contractor shall offer the work for inspection and approval at every stage before proceeding with the next stage. The record of inspection shall be maintained. Stages of inspection are as follows:

- (a) Surface preparation
- (b) Primer application
- (c) Each coat of paint

18.4.4 Any defect noticed during the various stages of inspection shall be rectified by the Contractor to the entire satisfaction of the Engineer-in-Charge before proceeding further. Irrespective of the inspection, repair and approval at intermediate stages of work the Contractor shall be responsible for making good any defects found during final inspection/guarantee period/defect liability period, as defined in General Conditions of Contract. Dry film thickness (DFT) shall be checked and recorded after application of each coat. The thickness shall be measured at as many locations as decided by the Engineer-in-Charge. The Contractor shall provide standard thickness measuring instrument such as elkometer (with appropriate range for measuring dry film thickness of each coat) free of cost to the Engineer-in-Charge whenever asked for.

18.5 Payment

Payment for painting of structural steel works shall be made on the basis of admissible weight in metric tons of the painted structures accepted by the Engineer-in-Charge.

The rate shall include supplying & applying the paint, specified in the tender, of approved quality and shade over the primer, specified in the tender, over the shop primer already applied to structural steel works of all types/shapes at all levels, locations & positions including storage, surface preparation, degreasing, cleaning, drying, touching up of shop primer coat, providing temporary staging, testing etc. all complete to the entire satisfaction of the Engineer-in-Charge.

ANNEXURE-'A'
(Clause 12.4)

Maximum Permissible Erection Tolerances

A. Columns

1. Deviation of column axes at foundation top level with respect to true axes.
 - i) In longitudinal direction ± 5 mm
 - ii) In lateral direction ± 5 mm
2. Deviation in the level of bearing surface of columns at foundation top with respect to true level ± 5 mm
3. Out of plumb (Verticality) of column axis from true vertical axis, as measured at top:
 - i) Upto and including 30m height whichever is less. $\pm H/1000$ or ± 25 mm
 - ii) Over 30m height $\pm H/1200$ or ± 35 mm whichever is less.
4. Deviation in straightness in longitudinal & transverse planes of column at any point along the height. $\pm H/1000$ or ± 10 mm whichever is less.
5. Difference in the erected positions of adjacent pairs of columns along length or across width of building prior to connecting trusses/beams with respect to true distance. ± 5 mm
6. Deviation in any bearing or seating level with respect to true level. ± 5 mm
7. Deviation in difference in bearing levels of a member on adjacent pair of columns both across & along the building. $+ 5$ mm

Note: 1. Tolerance specified under 3 should be read in conjunction with 4 & 5.

Note: 2. 'H' is the column height in mm.

B. Trusses

1. Shift at the centre of span of top chord member with respect to the vertical plane passing through the centre of bottom chord. $\pm 1/250$ of height of truss in mm at centre of span or ± 15 mm whichever is less.
2. Lateral shift of top chord of truss at the centre of span from the vertical plane passing through the centre of supports of the truss. $\pm 1/1500$ of span of truss in mm or ± 10 mm Whichever is less.
3. Lateral shift in location of truss from its true position. ± 10 mm

- | | | |
|--------------------------------------|---|---|
| 4. | Lateral shift in location of purlin from true position. | ± 5mm |
| 5. | Deviation in difference of bearing levels of truss from the true level. | ± 1/1200 of span of truss in mm or 20mm whichever is less. |
|
 | | |
| C. Gantry Girders & Rails | | |
| 1. | Shift in the centre line of crane rail with respect to centre line of web of gantry girder. | $\pm \left[\frac{\{\text{web thickness (mm)}\}}{2} + 2 \text{ mm} \right]$ |
| 2. | Shift of alignment of crane rail (in plan) with respect to true axis of crane rail at any point. | ± 5 mm |
| 3. | Deviation in crane track gauge with respect to true gauge. | |
| | i) For track gauge upto and including 15 m. | ± 5 mm. |
| | ii) For track gauge more than 15m.
Subject to maximum ± 10mm, where S in metres is true gauge. | ± [5 + 0.25 (S-15)] |
| 4. | Deviation in the crane rail level at any point from true level. | ± 10 mm. |
| 5. | Difference in level between crane track rails (across the bay) at | |
| | i) Supports of gantry girders | 15 mm. |
| | ii) Mid span of gantry girders | 20 mm. |
| 6. | Relative shift of crane rail surfaces (at a joining) in plan and elevation. | 2 mm. |

ANNEXURE-'B'
(Clause 18.1)

PAINTING COLOUR CODE FOR STRUCTURAL STEEL

1.	GANTRY GIRDER & MONORAIL	DARK GREEN
2.	GANTRY GIRDER & MONORAIL STOPPER SIGNAL	RED
3.	BUILDING STRUCTURAL STEEL COLUMNS, BRACKETS, BEAMS, BRACINGS, ROOF TRUSS, PURLINS, SIDEGIRTS, LOUVERS, STRINGERS	DARK ADMIRALITY GREY
4.	PIPE RACK STRUCTURE & TRESTLE	DARK ADMIRALITY GREY
5.	CHEQUERED PLATE (BOTH FACES)	BLACK
6.	GRATING	BLACK
7.	LADDER RUNGS	BLACK VERTICALS & CAGE RED
8.	HAND RAILING	
-	HANDRAIL, MIDDLE RAIL, TOE PLATE	SIGNAL RED
-	VERTICAL POST	BLACK

मानक विनिर्देशन
सिविल एवं संरचनात्मक कार्य

STANDARD SPECIFICATION
CIVIL & STRUCTURAL WORKS

संरचनात्मक इस्पात कार्य
(ट्यूबुलर/खोखले काट)

STRUCTURAL STEEL WORKS
(TUBULAR/HOLLOW SECTIONS)

8	13.05.25	UPDATED & REISSUED	RKA	VIKRAM	AS	M. NANDI
7	24.01.20	UPDATED & REISSUED	TK	AJS	RS	RK TRIVEDI
6	21.08.14	UPDATED & REISSUED	PM	AS	PKM	S.CHANDA
5	29.01.10	REAFFIRMED & ISSUED	AS	PKM	SCH	N. DUARI
4	18.04.00	UPDATED & REISSUED	DPN	RS	SCJ	MI
Rev. No	Date	Purpose	Prepared by	Checked by	Standards Committee Convenor	Standards Bureau Chairman
						Approved by

Abbreviations:

BIS : Bureau of Indian Standards
IS : Indian Standards

Structural Standards Committee

Convenor: Mr. Anurag Sinha

Members: Mr. Virender Goel
Mr. Deepak Agrawal
Ms. Alpana Srivastava
Dr. Sudip Paul
Mr. Charanjeet Singh (Projects)
Mr. Indrajit Neog (Construction)
Ms. Papia Mandal
Mr. Vikram Kumar Gupta

CONTENTS

1.0	SCOPE	4
2.0	REFERENCES	4
3.0	MATERIAL	4
4.0	FABRICATION DRAWINGS	5
5.0	FABRICATION	7
6.0	MARKING FOR IDENTIFICATION	8
7.0	SHOP ERECTION	8
8.0	INSPECTION AND TESTING	9
9.0	SHOP PAINTING, PACKING AND TRANSPORTATION	9
10.0	SITE (FIELD) ERECTION	9
11.0	SAFETY AND SECURITY DURING ERECTION	10
12.0	FIELD CONNECTIONS	10
13.0	GROUTING	10
14.0	SCHEME AND SEQUENCE OF ERECTION	11
15.0	PAINTING AFTER ERECTION	11
16.0	PAYMENT	11
17.0	PAYMENT	12
	ANNEXURE-'A'	13
	ANNEXURE-'B'	15

1.0 SCOPE

This specification covers the requirements for design (Refer Annexure 'A'), material, fabrication, modification, assembly, tests/ examinations, transportation, erection and painting preparation of fabrication drawings of bolted and/or welded structural steel works using tubular/ hollow sections for general construction work.

2.0 REFERENCES

2.1.1 BIS Codes

IS 800, IS 806, IS 816, IS 1161, IS 4923, IS 7205, IS 7215, IS 9595 & other relevant Codes.

2.1.2 International Standard

AWS D1.1 Structural Welding Code - Steel

2.2 EIL Specifications

6-68-0002 : Materials

6-68-0006 : Structural Steel Works

6-79-0020 : Standard specification for surface preparation and protective coating

2.3 In case of conflict between the clauses mentioned in this specification and those in the Indian Standards, this specification shall govern. Any special provision as shown or noted on the design drawings shall govern over the provisions of this specification.

3.0 MATERIAL

3.1 General

All materials shall conform to their respective specifications given in EIL Specification no. 6-68-0002. The use of equivalent or alternative materials shall be permitted only in very special cases and for all such cases prior written approval of the Engineer-in-Charge shall be obtained.

3.2 Receipt and Storing of Materials

3.2.1 Each section shall be marked for identification and each lot shall be accompanied by manufacturer's quality certificate, chemical analysis and mechanical characteristics.

3.2.2 All sections shall be checked, sorted out and arranged by grade and quality in the store. Any instruction given by the Engineer-in-Charge in this respect shall be strictly followed.

3.2.3 All material shall be free from surface defects such as pitting, cracks, laminations, twists etc. Defective material shall not be used and all such rejected material shall be immediately removed from the store/site. The decision of Engineer-in-Charge in this regard shall be final and binding.

3.2.4 Welding wires and electrodes (packed in their original cartons) shall be stored separately by quality and lots inside a dry and enclosed room in compliance with IS 9595 and as per instructions given by the Engineer-in-Charge. Electrodes shall be kept perfectly dry to ensure satisfactory operation and weld metal soundness.

3.2.5 Each lot of electrodes, bolts, nuts etc. shall be accompanied by manufacturer's quality test certificates.

3.2.6 All bolts (including nuts and washers) shall be checked, sorted out and arranged diameter-wise by grade and quality in the store.

3.3 Material Tests

3.3.1 The Contractor shall submit manufacturer's quality certificates for all the materials supplied by him. In case quality certificates are not available or are incomplete or when material quality differs from standard specifications, such materials shall not be used in the construction. However, the Contractor shall get all appropriate tests conducted in approved test houses for such materials as directed by the Engineer-in-Charge, at no extra cost to the owner and submit the same to the Engineer-in-Charge for his approval. The Engineer-in-Charge may approve the use of such materials entirely at his discretion.

3.3.2 The Contractor shall ensure that all material brought to site are duly approved by the Engineer-in-Charge. Rejected materials shall not be used and shall be removed from site forthwith. Any material of doubtful quality for which specific tests are to be carried out as per the instruction of the Engineer-in-Charge shall be separately stacked and properly identified.

4.0 FABRICATION DRAWINGS

4.1 Fabrication and erection drawings shall be prepared by the Contractor on the basis of "Approved for Construction" (AFC) design drawings, EIL Standards issued to the Contractor. These drawings shall be prepared by Contractor or by an agency engaged by the contractor using TEKLA or AUTODESK Advance Steel or equivalent 3D Modeling software and approved by the Engineer-in-Charge.

4.2 Fabrication and erection drawings shall be thoroughly checked, stamped "Approved for Construction" and signed by the Contractor's own responsible Engineer irrespective of the fact that such drawings are prepared by the Contractor or his approved agency, to ensure accuracy and correctness of the drawings. Unchecked and unsigned drawings shall not be used for the purpose of proceeding with the work. The Contractor shall proceed with the fabrication and erection work only after thoroughly satisfying himself in this regard.

4.3 All fabrication and erection drawings shall be issued for construction by the Contractor directly to his work site. Six copies of such drawings shall simultaneously be submitted to the Engineer-in-Charge who may check/ review some or all such drawings at his sole discretion and offer his comments for incorporation in these drawings by the Contractor.

However the contractor shall not proceed with the fabrication of such structures whose fabrication drawings are required to be reviewed before taking up the fabrication work as noted on "Approved for Construction" (AFC) design drawings issued to the contractor or as conveyed by the Engineer-in-Charge. The fabrication of such structures shall be done only as per the reviewed fabrication drawings.

The review of such drawings by EIL shall be restricted to the following only:

- a) Structural layout, orientation and elevation of structures/ members.
- b) Sizes of members
- c) Critical joint details

4.4 Fabrication drawings shall be drawn to scale and shall convey the information clearly and adequately. Following information shall be furnished on such drawings.

- a) Reference to design drawing number (along with revision number, if any) based on which fabrication drawing has been prepared.
- b) Structural layout, elevations & sections (with distinct erection marking of all members).
- c) Framing plans, member sizes, orientation and elevations.
- d) Layout and detailing of rain water pipes and gutters showing all necessary levels, connections and provisions wherever required.
- e) Detailing of shop/field joints/welds, connections, splices, for required strength and erection.
- f) Location, type, size and dimensions of welds and bolts.
- g) Shapes and sizes of edge preparation for welding.
- h) Details of shop and field joints/welds.
- i) Bill of materials.
- j) Quality of structural steel tubes, hollow sections, plates etc., welding electrodes, bolts, nuts and washers to be used.
- k) Erection assemblies identifying all transportable parts and sub-assemblies with special erection instructions, if required.
- l) Method of erection and special precautions to be taken during erection as required.
- m) Details of holes and fittings in components necessary for safe lifting and erection purpose.

4.5 The Contractor shall additionally ensure accuracy of the following and shall be solely responsible for the same:

- a) Provision for erection and erection clearances.
- b) Marking of members.
- c) Cut length of members.
- d) Matching of joints and holes.
- e) Provision kept in the members for other interconnected members.
- f) Bill of materials.

4.6 Connections, splices and other details where not shown on the design drawings shall be suitably designed and shown on the fabrication drawings based on good engineering practice developing full member strength. **Design calculations for such connections/ splices shall be submitted to the Engineer-in-Charge along with the fabrication drawings.**

4.7 Any substitution or change in section shall be allowed only when prior written approval of the Engineer-in-Charge has been obtained. Fabrication drawings shall be updated incorporating all such substitutions/changes by the Contractor at no extra cost to the owner.

- 4.8 In case during execution of the work, the Engineer-in-Charge on review of drawings considers any modifications/substitutions necessary to meet the design parameters/ good engineering practice, these shall be brought to the notice of the Contractor who shall incorporate the same in the drawings without any extra cost to the owner. The Contractor will be totally responsible for the correctness of the detailed fabrication drawings and execution of the work.
- 4.9 Contractor shall incorporate all the revisions made in the design drawings during the course of execution of work in his fabrication drawings, and resubmit the drawings at no extra cost to the owner. All fabrication shall be carried out only as per the latest AFC design drawings and corresponding fabrication drawings.
- 4.10 The Contractor shall supply two prints each of the final/as-built drawings along with their native soft files to Engineer-in-Charge for reference and record. The rates quoted shall include for the same.

5.0 FABRICATION

5.1 General

- 5.1.1 Fabrication of structures using tubular/hollow sections shall be done strictly as per "Approved For Construction" fabrication drawings (prepared by the Contractor based on the latest design drawings) and in accordance with IS 800, IS 806, IS 1161, IS 4923, IS 9595 and other relevant BIS Codes.
- 5.1.2 Prior to commencement of fabrication, undulations in the fabrication yard, if any, shall be removed and area levelled and paved by the Contractor.
- 5.1.3 Any defective material used in the work shall be replaced by the Contractor at his own expense. Necessary care and precautions shall be taken so as not to cause any damage to the structure during any such removal and replacement.
- 5.1.4 The components of the structure shall be assembled in such a manner that they are neither twisted nor otherwise damaged and be so prepared that the specified cambers, if any, are maintained.
- 5.1.5 Any faulty fabrication pointed out at any stage of work by the Engineer-in-Charge, shall be made good or replaced by the Contractor at his own cost.
- 5.1.6 Tolerances for fabrication of steel work shall conform to IS 7215.

5.2 Straightening & Bending

- 5.2.1 All materials before being assembled shall be straightened, if necessary (unless required to be of a curvilinear form) and shall be free from twist. Tubes shall not deviate from straightness by more than 1/600 of any length.
- 5.2.2 Bending of structural hollow or tubular sections shall be done by cold process to shapes as shown on drawings.

5.3 Cut Edges

Edges shall be dressed to a neat and workman like finish and be free from distortion.

5.4 Caps and Bases for Columns

The ends of all tubes and hollow sections for columns (transmitting loads through the ends) shall be ground flush and made true square to the axis of the member and shall be provided with caps and base plates as shown on the drawings.

5.5 Sealing of Tubes and Hollow Sections

When the end of member is not automatically sealed by virtue of its connection by welding to another member, the end shall be properly and completely sealed against ingress of moisture. Before sealing, the inside of the tubes and hollow sections shall be made dry.

5.6 Flattened Ends

In tubular construction, joints may be formed by flattening or splitting or otherwise formed shapes for welded or bolted connections. The change in section shall be gradual to avoid concentration of stresses and all flattening shall be done by cold process only.

5.7 Welding

Welding shall be strictly in accordance with IS 9595 and carried out by experienced welders only. For welding (including testing & examining of welds) relevant clauses of EIL Specification no. 6-68-0006 for Structural Steel Works shall be referred to the extent applicable.

5.8 Bolting

- 5.8.1 Washers shall be specially shaped where necessary to give the nuts and the heads of bolts a full bearing.
- 5.8.2 In all cases where the full bearing area of the bolt is to be developed, the threaded portion of the bolt shall not be within the thickness of parts bolted together, and washer(s) of appropriate thickness shall be provided to allow the nut to be completely tightened.
- 5.8.3 The threaded portion of each bolt shall project through the nut at least one thread.
- 5.8.4 Different bolt grades of the same diameter shall not be used in the same structure, except if agreed otherwise by the Engineer-in-Charge.
- 5.8.5 Bearing type bolts shall be used (unless noted otherwise) and tightened firmly by available means.

6.0 MARKING FOR IDENTIFICATION

Each component shall be distinctly marked before delivery, in accordance with the marking diagram and shall bear such other marks as will facilitate erection.

7.0 SHOP ERECTION

The steel work shall be temporarily shop erected complete or as directed so that accuracy of fit may be checked before dispatch.

8.0 INSPECTION AND TESTING

- 8.1 The Engineer-in-Charge (or his authorised representative) shall have free access at all times to those parts of the Contractor's Works which are concerned with the storing and fabrication of the steel work and shall be provided with all reasonable facilities for satisfying himself that fabrication is being undertaken in accordance with the provisions of these specifications and other relevant BIS Codes.
- 8.2 Should any structure or part of a structure be found not to comply with any of the provisions of these specifications and other relevant BIS Codes, it shall be rejected. No structure or part of the structure, once rejected shall be resubmitted for inspection, except in cases where the Engineer-in-Charge or his authorised representative considers the defect as rectifiable.
- 8.3 Defects which may appear during fabrication/erection shall be made good only with the consent of the Engineer-in-Charge and procedure laid down by him.
- 8.4 All necessary gauges and templates shall be supplied free to the Engineer-in-Charge by the Contractor whenever asked for during inspection. The Engineer-in-Charge may, at his discretion, check the test results obtained at the Contractor's works by independent tests at a test house, the cost of such tests shall be borne by the Contractor.

9.0 SHOP PAINTING, PACKING AND TRANSPORTATION

- 9.1 All components and members of steel work shall be given one shop coat of primer as specified in the tender, immediately after the surface have been properly prepared (i.e. degreased, derusted, descaled and cleaned) in accordance with EIL Specification No. 6-79-0020 or the job specification, as applicable.
- 9.2 All items shall be suitably packed in case they are to be dispatched from the fabrication shop to the actual site of erection so as to protect them from any damage or distortion during transit.

10.0 SITE (FIELD) ERECTION

10.1 Plant and Equipment

The suitability and capacity of all plant and equipment used shall be to the complete satisfaction of the Engineer-in-Charge.

10.2 Storing and Handling

All steel work shall be so stored and handled at site so that the members are not subjected to excessive stresses and any damage.

10.3 Setting out

Prior to setting out of the steel work, the Contractor shall get himself satisfied about the correctness of levels, alignment, location of existing pedestals/ columns and holding down bolts/ pockets provided therein. Any minor modification in the same including chipping, cutting and making good, adjusting the anchor bolts etc. if necessary, shall be carried out by the Contractor at his own expense. The positioning and levelling of all steel work including plumbing of columns and placing of every part of the structure with accuracy shall be in accordance with the drawings and to the complete satisfaction of the Engineer-in-Charge.

10.4 Tolerances

Tolerances for erection of steel structures shall be as per Annexure - 'B'.

11.0 SAFETY AND SECURITY DURING ERECTION

11.1 The Contractor shall comply with IS 7205 for necessary safety and adhere to safe erection practices and guard against hazardous and unsafe working conditions during all stages of erection.

11.2 During erection, the steel work shall be securely bolted or otherwise fastened, and when necessary, temporarily braced to provide for all loads to be carried by the structure during erection till the completion including those due to wind, erection equipment and its operation etc. For the purpose of guying the Contractor shall not use other structures in the vicinity without prior written permission of the Engineer-in-Charge.

11.3 No permanent bolting or welding shall be done until proper alignment has been achieved.

11.4 Proper access, platform and safety arrangement shall be provided for working and inspection at no extra cost whenever required.

12.0 FIELD CONNECTIONS

12.1 Field Bolting

12.1.1 Field bolting shall be carried out with the same care as required for shop bolting.

12.2 Field Welding

12.2.1 All field assembly and welding shall be executed in accordance with the requirements for shop. Holes for all erection bolts where removed after final erection shall be plugged by welding. Alternatively erection bolts may be left and secured. Proper access, platform and safety arrangements shall be provided for inspection whenever required.

13.0 GROUTING

13.1 Prior to positioning of structural columns/ girders/ trusses over the concrete pedestals/ columns/ brackets, all laitance & loose material shall be removed by wire brushing & chipping. The bearing concrete surfaces shall be sufficiently leveled, hacked with flat chisels to make them rough, cleaned (using compressed air) and made thoroughly wet. All pockets for anchor bolts shall be thoroughly cleaned and excess water, if any, shall be removed. Thereafter, the structural members shall be erected, aligned & plumbed maintaining the base plates/ shoe plates at the levels shown in the drawings, with necessary shims/ pack plates/ wedges.

13.2 After final alignment and plumbing of the structure, the forms shall be constructed around and joints made tight to prevent leakage. Grouting (under the base plates/ shoe plates including grouting of sleeves & pockets) shall be done with non-shrink grout having compressive strength (28 days) not less than 40 N/sq.mm. Non shrink grout shall be of free flow premix type of approved quality and made and mixed with water in proportion as specified by the manufacturer. Ordinary 1:2 cement/ sand mortar grout shall be used only for small, isolated structures e.g. operating platforms not supporting any equipment, pipe supports, cross overs, stairs & ladders. The thickness of grout shall be as shown on the

drawings. In case, not mentioned grout thickness shall not be less than 25mm nor more than 50mm in any case.

- 13.3 The grout mixture shall be poured continuously (without any interruption till completion) by grouting pumps from one side of the base plate and spread uniformly with flexible steel strips and rammed with rods, till the space is filled solidly and the grout mixture carried to the other side of the base plate.
- 13.4 The grout mixture shall be allowed to harden for a period as decided by the Engineer-in-Charge. At the end of this period, the shims/ wedges/ pack plates may be removed and anchor bolts tightened uniformly. The alignment of the structure shall now be rechecked and if found correct, the voids left by the removal of shims/ wedges/pack plates (if removed) must be filled up with a similar mixture of grout. In case after checking, serious misalignment is indicated, the grout shall be removed completely and fresh grouting done after making appropriate correction of alignment.

14.0 SCHEME AND SEQUENCE OF ERECTION

The Contractor shall furnish the detailed scheme and sequence of erection to match with the project schedule and get the same approved by the Engineer-in-Charge. All necessary co-ordination and synchronization shall be done with the civil contractor where civil works are not included in the scope of structural contractor at no extra cost so as to match with the project schedule.

15.0 PAINTING AFTER ERECTION

Painting of Structural Steel Works using (tubular/ hollow sections) shall be done in accordance with relevant clauses of EIL Specification no. 6-68-0006.

16.0 PAYMENT

(Where design and design drawings are excluded from the scope of the Contractor)

- 16.1 Payment for structural steel works fabricated and made out of tubular/ hollow sections shall be made on the basis of admissible weight in metric tons (determined as described in clause 16.2 to 16.3) of the structure accepted by the Engineer-in-Charge.

The rate shall include supplying (as per supply conditions given in the tender), fabricating, erecting in position (at all levels and locations), transporting, storing, testing/examining of bolted and/or welded structural steel works using (tubular/hollow sections) of all types of trusses, girders, purlins, side rails, columns, runners, beams, ties, portals, framework, bracings, brackets, sag rods etc., including all handling, straightening/bending, if required, cutting, edge preparation, welding and/or bolting of joints, providing temporary bracing, providing and fixing end caps, associated plates welded/ bolted to the tubular/ hollow sections (like gusset plates, stiffeners, fin plates, etc.), fixing in line and level with necessary temporary staging, grouting with premix, free flow, non-shrink grout as shown on drawings including preparation of detailed fabrication drawings and getting them reviewed, preparing the exposed surface for painting, surface cleaning, wire brushing, removal of mill scale, rust, oil or grease and applying the primer as specified after fabrication, return the surplus materials to the owner's stores and material reconciliation in the case of materials supplied by Owner as per relevant contract conditions etc. all complete for all the operations mentioned in the foregoing clauses.

16.2 The weight for payment shall be determined from the fabrication drawings and respective bill of materials prepared by the Contractor. The bill of materials shall be checked and approved by the Engineer-in-Charge before making the payment. The weight shall be calculated on the basis of BIS Handbook, wherever applicable. In case sections used are different from BIS sections, then Manufacturer's Handbook shall be adopted. No allowance in weight shall be made for rolling tolerances.

16.3 Welds, bolts, nuts, washers, shims, pack plates and grout shall not be measured. The quoted rate shall be deemed to include the same.

17.0 PAYMENT

(Where design and design drawings are also included in the scope of the Contractor).

17.1 All design and design drawings shall be prepared strictly in accordance with DESIGN SPECIFICATIONS attached with this specification as Annexure - 'A'.

17.2 Payment for structural steel works fabricated and made out of tubular/hollow sections shall be made on the basis of admissible weight in metric tons (determined as described in clause 17.3 to 17.4) of the structure accepted by the Engineer-in-Charge.

The rate shall include supplying, fabricating, erecting in position (at all levels and locations), transporting, storing, testing/examining of bolted and/or welded structural steel works using (tubular/hollow sections) of all types of trusses, girders, purlins, side rails, columns, runners, beams, ties, portals, framework, bracings, brackets, sag rods etc., including all handling straightening/bending if required, cutting, edge preparation, welding and/or bolting of joints, providing temporary bracing, providing and fixing end caps, associated plates welded/bolted to the tubular/ hollow sections (like gusset plates, stiffeners, fin plates, etc.) fixing in line and level with necessary temporary staging, grouting with premix, free flow, non-shrink grout as shown on drawings including preparation of detailed fabrication drawings and getting them reviewed, preparing the exposed surface for painting, surface cleaning, wire brushing, removal of mill scale, rust, oil or grease and applying the primer as specified after fabrication, return the surplus materials to the owner's stores and material reconciliation in the case of materials supplied by Owner as per relevant contract conditions etc. all complete for all the operations mentioned in the foregoing clauses.

17.3 The weight for payment shall be determined from the fabrication drawings and respective bill of materials prepared by the Contractor. The bill of materials shall be checked and approved by the Engineer-in-Charge before making the payment. The weight shall be calculated on the basis of BIS Handbook wherever applicable. In case sections used are different from BIS sections, then Manufacturer's Handbook shall be adopted. No allowance in weight shall be made for rolling tolerances.

17.4 Welds, bolts, nuts, washers, shims, pack plates and grout shall not be measured. The quoted rate shall be deemed to include the same.

ANNEXURE - 'A'
(Clause no. 1.0 & 17.1)

DESIGN SPECIFICATIONS

1.0 DESIGN AND DESIGN DRAWINGS

Design shall be done based on Engineering Design Basis or Scope of Work attached with Tender document. Wherever the same is not available, the following design specification shall be adopted:

- 1.1 The design and design drawings of the structure(s) shall be prepared by the Contractor on the basis of conceptual drawing(s) furnished to him. These (design and design drawings) shall be prepared in his own design office, or in case such facility is not available with the Contractor, by an approved and established agency. The names of agencies who may be considered for entrusting with this work shall be submitted along with the offer for approval of the Engineer-in-Charge. If none of the agencies so named is approved, the Contractor shall submit a fresh list for approval.
- 1.2 The design shall be done in accordance with IS 800, IS 801, IS 806, IS 1161 & IS 4923, and other relevant BIS Codes (latest revisions). The loads to be adopted in the design shall be in accordance with IS 875 & IS 1893 except otherwise specified. All design calculations and design drawings shall be prepared in metric units i.e. dimensions in millimetres and levels in metres.
- 1.3 The basic consideration for design of structural framework shall primarily be its stability, ease of fabrication and erection, overall economy satisfying the relevant BIS Codes of Practice and satisfactory performance. All structures shall be designed to withstand the worst combination of loading.
- 1.4 Structures, in general, shall be of welded construction. Roof trusses shall have a slope of 1:3 (1 vertical : 3 horizontal). Purlins shall be spaced in such a manner so as to achieve maximum economy in the use of roof sheets. Camber (span/500) shall be provided for trusses having span of 15 meters and above. The minimum thickness of gussets shall be 8mm.
- 1.5 All design calculations (supplemented with necessary explanatory sketches, computer outputs & explanatory notes) shall be done in a neat and systematic manner so as to facilitate review of the same. The design drawings shall include the following:
 - a) Structural layout, elevations, sections.
 - b) Sizes of members and tables showing forces in members under different loading conditions.
 - c) Proposed sizes of sheets and extent of sheeting (to be represented by chain dotted lines)
 - d) Blown up details of typical joints, connections, splices etc.
 - e) Size and type of welds/bolts
 - f) Quality of tubular/hollow sections and structural steel bolts etc.
 - g) Approximate quantity (Metric Tons)

- h) Chart/table showing loading (under different conditions) and fixing details at base (required for the design of supporting structure/foundations which shall be in the Owner's scope of work)
- 1.6 All design calculation sheets and design drawings shall be thoroughly checked, approved, stamped "Approved For Construction" and signed by a competent design engineer (engaged by the Contractor) prior to their submission to the Engineer-in-Charge for review. Unchecked and unsigned design calculations and design drawings shall not be accepted for review and shall be returned forthwith to the Contractor.
- 1.7 The Contractor shall submit the design calculations (3 sets) and design drawings (6 sets) for review to the Engineer-in-Charge. Any comments/ suggestions given by him shall be incorporated in the design/ design drawings (without any extra cost to the Owner) and resubmitted for review. However, it shall be clearly understood that review by the Engineer-in-Charge shall not relieve the Contractor of his responsibility for the correctness of design, drawings and execution of the works. Any defect observed either during construction/erection or till the defect liability period of works shall be rectified and removed by the Contractor without any cost implication.
- 1.8 The design calculations and design drawings for the building(s) shall be submitted by the Contractor in one lot so as to facilitate an overall systematic review by the Engineer-in-Charge.
- 1.9 The Contractor shall supply the all native soft files of all design calculations and design drawings at no extra cost to the Owner, for record.
- 1.10 **Based on the final design drawings, the Contractor shall prepare necessary fabrication drawings in conformity with clause 4.0 of EIL Specification no. 6-68-0007.**

ANNEXURE - 'B'
(Clause 10.4)

MAXIMUM PERMISSIBLE ERECTION TOLERANCES

A. COLUMNS.

1. Deviation of column axes at foundation top level with respect to true axes.
 - i) In longitudinal direction ± 5 mm
 - ii) In lateral direction ± 5 mm
2. Deviation in the level of bearing surface of columns at foundation top with respect to true level. ± 5 mm
3. Out of plumbness (verticality) of column axis from true vertical axis, as measured at top:
 - i) Upto and including 30 m height $\pm H/1000$ or ± 25 mm
(whichever is less)
 - ii) Over 30 m height $\pm H/1200$ or ± 35 mm
(whichever is less)
4. Deviation in straightness in longitudinal and transverse planes of column at any point along the height. $\pm H/1000$ or ± 10 mm
(whichever is less)
5. Difference in the erected positions of adjacent pairs of columns along length or across width of building prior to connecting trusses/beams with respect to true distance ± 5 mm
6. Deviation in any bearing or seating level with respect to true level ± 5 mm
7. Deviation in difference in bearing levels of a member on adjacent pair of columns both across and along the building ± 5 mm

Notes:

1. Tolerance specified under 3 should be read in conjunction with 4 & 5.
2. 'H' is the column height in mm.

B. TRUSSES:

- 1) Shift at the centre of span of top chord member with respect to the vertical plane passing through the centre of bottom chord. : $\pm 1/250$ of Height of truss in mm at the centre of span or ± 15 mm (whichever is less)
- 2) Lateral shift of top chord of truss at the centre of span from vertical plane passing through the centre of supports of the truss : $\pm 1/1500$ of span of truss in mm or ± 10 mm (whichever is less)
- 3) Lateral shift in location of truss from its true vertical position : ± 10 mm
- 4) Lateral shift in location of purlin from true position : ± 5 mm
- 5) Deviation in difference of bearing levels of truss from the true level : $\pm 1/1200$ of span of truss in mm or ± 20 mm (whichever is less)

मानक विनिर्देशन
सिविल एवं संरचनात्मक कार्य

STANDARD SPECIFICATION
CIVIL & STRUCTURAL WORKS

विभिन्न इस्पात कार्य

MISCELLANEOUS STEEL WORKS

9	11.12.25	REVISED & REISSUED	CK	AJS	AS	MN
8	18.04.25	REVISED & REISSUED	TK	AJS	AS	MN
7	27.08.18	REVISED & REISSUED	AS	AS	RS	RKT
6	24.01.14	REVISED & REISSUED	AJS	RS	PKM	SC
5	10.06.08	REVISED & REISSUED	PKB	PKM	VK	VC
Rev. No	Date	Purpose	Prepared by	Checked by	Standards Committee Convenor	Standards Bureau Chairman
						Approved by

Abbreviations:

AFC	:	Approved for Construction
BIS	:	Bureau of Indian Standards
DIN	:	Deutsches Institut für Normung (German Institute for Standardization)
EN	:	European Standards
IS	:	Indian Standard
ISO	:	International Organization for Standardization
MS	:	Mild Steel
PCC	:	Plain Cement Concrete
RCC	:	Reinforced Cement Concrete

Structural Standards Committee

Convenor: Mr. Anurag Sinha

Members: Mr. Virender Goel
Mr. Deepak Agrawal
Ms. Alpana Srivastava
Dr. Sudip Paul
Ms. Papia Mandal
Mr. Vikram Kumar Gupta
Mr. Charanjit Singh (Projects)
Mr. Indrajit Neog (Construction)

CONTENTS

1.0	GENERAL	4
2.0	REFERENCES	4
3.0	MATERIAL	4
4.0	ANCHOR BOLTS	4
5.0	METAL INSERTS	5
6.0	CHEQUERED PLATES	6
7.0	GRATINGS	7
8.0	TUBULAR HAND RAILING	8
9.0	MILD STEEL RUNGS	9
10.0	LIGHT GAUGE STEEL STRUCTURAL SECTIONS	9
11.0	MECHANICAL ANCHOR FASTENERS	10
12.0	CHEMICAL ANCHOR FASTENERS AND DOWELS	12

1.0 GENERAL

- 1.1 All materials supplied by the Contractor shall conform to specifications given in EIL Standard Specification No. 6-68-0002.
- 1.2 The Contractor shall furnish test certificates for all materials prior to their use in the works. Structural steel materials not supported by mill test certificates may be used after confirming their quality by carrying out appropriate tests in accordance with the method specified in IS 1608.
- 1.3 Other requirements not covered under this specification shall be in accordance with EIL Standard Specification No. 6-68-0006.

2.0 REFERENCES

As mentioned in the respective clauses.

3.0 MATERIAL

As mentioned in the respective clauses.

4.0 ANCHOR BOLTS

4.1 Material

Materials for anchor bolts, nuts, locknuts, washers, pipe sleeves and anchor plates shall conform to their respective clauses given in EIL Standard Specification No. 6-68-0002.

4.2 Fabrication

Fabrication of anchor bolts and their complete assemblies shall be strictly in compliance with the specifications and drawings/standards.

4.3 Placement

Anchor bolt assemblies shall be placed in position strictly as per drawings and securely held during pouring and vibrating of concrete with necessary templates and other dummy structures to prevent their dislocation.

4.4 Tolerances

Tolerances allowed for anchor bolts positioning shall be as below:

- For sleeved bolts, one tenth of the bolt nominal diameter.
- For bolts without sleeves, one twentieth of the bolt nominal diameter.

4.5 Protection

The exposed surfaces of bolts shall be properly covered (after greasing of bolts and packing of sleeves) with jute cloth so as to protect them from damage till final erection of structure/equipment is over.

4.6 Payment

- 4.6.1 Payment shall be made on the basis of actual weight in metric tons of the anchor bolt/anchor bolt assembly. The rate shall include supply (as per scope of supply conditions given in the

tender) of all materials, handling, transporting, fabrication, turning from available size to required diameter, threading, welding, fixing in position at all levels and locations, providing necessary templates, greasing, packing of sleeves, covering with jute cloth and other protective measures etc. all complete.

4.6.2 The rate shall cover bolt of any diameter and nomenclature.

4.6.3 Payment for fixing anchor bolt assembly (already fabricated and supplied by the Owner as free issue) in position shall be made on the basis of actual weight of anchor bolts/bolt assemblies in metric tons. The rate shall include handling, transporting, fixing in position at all levels and locations, welding if required, providing necessary templates, greasing, packing of sleeves, covering with jute cloth and other protective measures etc. all complete.

4.6.4 No separate payment shall be made for templates, dummy structures, supports etc. and the rate quoted shall be inclusive of all cost related to such provision required for correct and accurate installation of anchor bolts/anchor bolt assembly.

5.0 METAL INSERTS

5.1 Material

Materials required for fabricating metal inserts shall conform to their respective specification given in EIL Standard Specification No. 6-68-0002.

5.2 Fabrication

Fabrication of inserts shall be done strictly as per drawings/standards and in compliance with the requirements given in EIL Standard Specification No. 6-68-0006.

5.3 Placement

Metal inserts shall be correctly embedded (in plain concrete/ reinforced concrete) as per their location shown on the drawings. Care shall be taken that these are securely held in position and do not get disturbed during concreting. Where necessary, these may be welded to the reinforcement bars. Suitable templates, spacers, dummy structures and temporary staging shall be provided. Necessary cutting in the formwork and adjustment of reinforcement bars shall be done for the placement of metal inserts where required.

5.4 Painting

The exposed surfaces of metal inserts shall be cleaned and given one coat of primer as per EIL Standard Specification No. 6-79-0020 or job specification (wherever applicable), as specified, after fabrication.

5.5 Payment

Payment shall be made on the basis of actual weight in metric tons of the metal inserts. The rate shall include supply (as per supply conditions given in the tender) of all materials, handling, transporting, fabrication, welding, fixing in position at all levels and locations, providing necessary templates, spacers, dummy structures, adjusting the formwork and reinforcement, staging, preparation of surface for painting, applying one coat of primer as per EIL Standard Specification No. 6-79-0020 or job specification (wherever applicable), as specified, etc. all complete.

6.0 CHEQUERED PLATES

6.1 Material

Material required for chequered plates shall conform to the specifications given in EIL Standard Specification No. 6-68-0002. Chequering shall be closed or open-ended or of any other pattern as shown on drawings.

6.2 Fabrication Drawings

As per the requirements given in EIL Standard Specification No. 6-68-0006.

6.3 Fabrication

Chequered plates shall be fabricated as per the "Approved for Construction" fabrication drawings (prepared by the Contractor based on design drawings). These shall be perfectly flat and without any dents/deformations and shall be cut to the required size and shape. Holes/ notches/ openings of the required size, if any, shown on drawings shall be made. Nosing for staircase treads shall be made by cold bending of chequered plates. All edges shall be made smooth and even. All chequered plate units shall be given distinct erection marks in accordance with the marking drawings. Stiffeners of any description shall be welded with the chequered plates where shown on drawings.

6.4 Erection/Fixing

Chequered plates shall be fixed to the bearing members by welding/ bolting/ screwing as shown on drawings. All bolts/ screws shall be of counter-sunk type so that the heads remain flush with the top of plate. Where welding is used for fixing, stitch welds of minimum 50mm length with a pitch of 150 mm shall be used. Continuous sealing run of weld shall be provided along the junction of two consecutive chequered plates parallel to the span. For removable flooring, details as shown on drawings shall be followed.

6.5 Painting

Chequered plates shall be cleaned (both the surfaces) and given one coat of primer/ galvanization as per EIL Standard Specification No. 6-79-0020 or job specification, as specified, on both surfaces.

6.6 Payment

6.6.1 Payment shall be made on the basis of actual weight in metric tons of the chequered plate. If any stiffening sections are provided below the chequered plates for strengthening, the same shall be separately measured & paid under Structural Steel item (Refer EIL Standard Specification No. 6-68-0006).

6.6.2 The rate shall include supplying (as per supply conditions given in the tender), fabricating, erecting M.S. chequered plates including transporting, handling, straightening if required, cutting to required size and shape, making holes/ notches/ opening of required size and nosing, smoothening the edges, fixing by welding/bolting/screwing, at all levels and locations, preparing detailed fabrication drawings, surface cleaning, removal of rust, scale, grease and applying one coat of primer/ galvanization as per EIL Standard Specification No. 6-79-0020 or job specification (wherever applicable), as specified, etc. all complete.

6.6.3 Welds, bolts, nuts, screws, washers, clips shall not be measured. The quoted rate shall be deemed to include the same.

7.0 GRATINGS

7.1 Categories

Electroforged Carbon Steel/ Stainless Steel gratings shall be either Type-I or Type-II as per EIL Standard No. 7-68-0697 and shall be procured from approved manufacturers as per Departmental List of Approved Manufacturers.

7.2 Material

Materials for fabrication and fixing of Gratings shall conform to EIL Standard No. 7-68-0697 and EIL Specification No. 6-68-0002.

7.3 Fabrication Drawings

As per the requirements given in EIL Standard Specification No. 6-68-0006.

7.4 Fabrication

The gratings shall be manufactured by electroforging process strictly as per the "Approved for Construction" fabrication drawings prepared by the Contractor based on EIL standard. All units shall be given distinct erection marks in accordance with the marking drawing. The Contractor shall submit sample gratings for inspection and approval by the Engineer-in-Charge whenever asked for.

7.5 Erection/Fixing

Gratings shall be fixed to the bearing members by welding, clamping/ disc and bolting/ studs as indicated in the Standard.

7.6 Galvanisation

Carbon steel gratings and the fixing clamps, bolts, nuts shall be cleaned as per EIL Standard Specification No 6-79-0020 or job specification (wherever applicable), as specified and galvanisation shall be done as specified in accordance with IS 2629 and tested as per IS 2633 & IS 6745. Carbon Steel Disc & Stud shall either be hot dip galvanized or shall have a coating that can withstand neutral salt spray test of 2000H as per DIN EN ISO 9227.

7.7 Payment

7.7.1 Payment shall be made on the basis of actual weight in metric tons of the gratings manufactured in accordance with EIL Standard and accepted by the Engineer-in-Charge.

The weight for payment shall also include the weight of galvanization and welding.

7.7.2 The rate shall include supplying, fabricating, erecting electroforged Carbon steel/ Stainless steel gratings (of the specified category) including transporting, handling, cutting to required size and shape, making holes/ notches/ openings, smoothening the edges, fabricating clamps/discs, fixing by welding/ clamping/ bolting/ disc & stud, at all levels and locations, preparing detailed fabrication drawings, surface cleaning, removal of rust, scale, grease and carrying out galvanization on Carbon steel gratings, clamps, nuts & bolts and/or a coating on Carbon steel discs & studs that can withstand neutral salt spray test of 2000H as per DIN EN ISO 9227, repairing the damaged area of galvanized coating using cold galvanizing spray process for Carbon steel grating, chemical treatment of Stainless steel grating, etc. all complete.

7.7.3 Bolts, clamps/ discs, nuts/ studs and washers for both Carbon steel and Stainless steel gratings shall not be measured. The quoted rate shall be deemed to include the same.

8.0 TUBULAR HAND RAILING

8.1 Material

Materials for fabrication and fixing of Tubular Hand Railing shall confirm to specification given in EIL Standard Specification No. 6-68-0002.

8.2 Fabrication Drawings

As per the requirements given in EIL Standard Specification No. 6-68-0006.

8.3 Fabrication

8.3.1 Hand railing shall be fabricated strictly as per the "Approved for Construction" fabrication drawings prepared by the Contractor based on design drawings and standards. All tubes shall be straight and without any dents/ deformations. Tubes shall be cut and ends shall be prepared to a neat and workman-like finish. All elements shall be directly welded. All welded joints shall be cleaned and filed or ground smooth, if required, to have a smooth surface and aesthetically pleasant appearance. Splicing of top rail shall not be allowed. Tubes shall be cold bent to shape and curvature in case of discontinuous ends of handrails. Ripples, kinks and/ or dents at bends shall not be accepted.

8.3.2 Lower ends of vertical posts shall be cut and splayed (for grouting in pockets in the concrete members). For removable type of hand railing, suitable base plates (with provision for bolting) shall be welded to the lower end of vertical posts. All units shall be given distinct erection marks in accordance with the marking drawing.

8.4 Erection/ Fixing

Hand railing shall be fixed to the bearing members by welding/ bolting/ grouting as indicated on the drawings. Local notching shall be made in the floor plate/ grating to accommodate vertical posts/ their base plates which shall always be welded to the main supporting member. When the posts are to be fixed in concrete members, suitable pockets shall be made in concrete for grouting as shown on drawings/standards.

8.5 Painting

All hand railing components shall be cleaned and given one coat of primer/ galvanization as per EIL Standard Specification No. 6-79-0020 or job specification (wherever applicable), as specified, after fabrication.

8.6 Payment

8.6.1 Payment shall be made on the basis of measured length in meters (m) of top rail only (Horizontal and/or inclined lengths). The rate shall include preparation of fabrication drawings, supply of all materials, handling, transporting, straightening if required, cutting to required size, bending, welding, bolting, fixing in position at all levels and locations, grouting with 1:2 (cement: sand) mortar, surface cleaning, removal of rust, scale, grease and applying one coat of primer/ galvanization as per EIL Standard Specification no. 6-79-0020 or job specification (wherever applicable), as specified, after fabrication etc. all complete.

8.6.2 The rate shall include making suitable notches in floor plates/ gratings and pockets in concrete structures for fixing the vertical posts.

9.0 MILD STEEL RUNGS

9.1 Material

All materials shall conform to specifications given in EIL Standard Specification No. 6-68-0002.

9.2 Fabrication

Rungs shall be fabricated as per EIL standards/ drawings. Mild steel bars shall be straightened if required, cut, bent to shape and given one coat of primer and two coat of finish paints per EIL Standard Specification No. 6-79-0020 or job specification (wherever applicable) as specified, on exposed portions after fabrication.

9.3 Fixing

Rungs shall be fixed in position as per detailed drawing and firmly tied/welded with reinforcement to prevent their displacement during vibration of concrete.

9.4 Payment

Payment shall be made on the basis of actual weight in kilogram (Kg) of the M.S. rungs. The rate shall include supply of all materials, handling, transporting, straightening if required, cutting to required size, bending to shape, tying/welding with reinforcement bars, fixing at all levels and locations, adjustment of formwork, applying one coat of primer and two coats of finish paint as per EIL Standard Specification No. 6-79-0020 or job specification (wherever applicable), as specified, on the exposed portion of rungs etc. all complete.

10.0 LIGHT GAUGE STEEL STRUCTURAL SECTIONS

10.1 Material

All materials required for fabrication and fixing in position of Light Gauge Steel Structural Sections shall conform to EIL Standard Specification No. 6-68-0002.

10.2 Fabrication Drawings

As per the requirements given in EIL Standard Specification No. 6-68-0006.

10.3 Fabrication

10.3.1 Fabrication of members shall be done strictly as per the "Approved for Construction" fabrication drawings prepared by the Contractor based on the latest design drawings and in accordance with IS 800, IS 801 and other relevant BIS Codes.

10.3.2 All members shall be straight and free from any dents/deformations/ twists. Members shall be cut to the required sizes and ends prepared to a neat and workman like finish. Holes (for sag rods and cleat bolts) of appropriate size shall be drilled and all members/ components shall be given distinct erection marks in accordance with the marking drawings. Holes shall not be formed by gas cutting process.

10.4 Erection

Structural members shall be erected in proper sequence and aligned properly without causing any twist. Permanent bolting/ welding shall be done only after proper alignment has

been achieved. Proper access, working platforms and safety arrangements shall be provided by the Contractor for working and inspection.

10.5 Painting

All structural components shall be cleaned and given one coat of primer as per EIL Standard Specification No. 6-79-0020 or job specification (wherever applicable), as specified, after fabrication.

10.6 Payment

10.6.1 Payment shall be made on the basis of admissible weight in metric tons of the structure accepted by the Engineer-in-Charge. The weight for payment shall include all structural members, cleats, splices, gussets and sag rods and shall be determined from the fabrication drawings along with respective bill of materials prepared by the Contractor. The bill of materials shall be checked and approved by the Engineer-in-Charge before making the payment. The weight shall be calculated as per IS 808/ IS 1161. BIS Handbook/ Manufacturer's catalogues/ charts shall be adopted in case relevant weights of sections used are not covered in IS 808/ IS 1161. No allowance in weight shall be made for rolling tolerances. In case of any doubt, actual weight of the section shall be measured at site.

The rate shall include supplying, fabricating, erecting, at all levels and locations, testing of bolted and/ or welded Light Gauge structural steel works including cleats, crook bolts, splices/ sleeves, all other fixtures and accessories, straightening if required, cutting, edge preparation, welding and bolting of joints, fixing in line and level with temporary staging and removal of the same after final alignment, handling, transporting, storage, preparation of detailed fabrication drawings and getting them reviewed by the Engineer-in-Charge, surface cleaning, removal of scale, rust, oil or grease and applying one coat of primer as per EIL Standard Specification No. 6-79-0020 or job specification (wherever applicable), etc., all complete.

10.6.2 All welds, bolts, nuts, washers, fixtures and accessories shall not be measured. The quoted rate shall be deemed to include the same.

11.0 MECHANICAL ANCHOR FASTENERS

Design and testing of Mechanical Anchor Fasteners shall conform to IS 1946 Part-2 and Part-4 respectively or they shall be approved by European Organization for Technical Approval (EOTA) / Deutsches Institut für Bautechnik (DIBt)/ Factory Mutual Laboratories (FM)/ International Code Council- Evaluation Services (ICC-ES formerly ICBO-ES) for use in Cracked Concrete.

Design of post-installed Mechanical anchor fasteners shall be provided/ verified by the approved manufacturer with installation instructions and execution shall be done by an applicator trained by the approved manufacturer (preferably in the presence of manufacturer for critical applications/ structures).

11.1 Material

Mechanical Anchor Fasteners shall be of minimum grade 5.8 galvanised to at least 5 microns or Stainless Steel (SS304 or SS316) and shall be approved for use in cracked concrete.

Stainless steel Mechanical anchor fasteners shall be preferred for sites located in coastal areas or in high rainfall zone.

11.2 Classification

11.2.1 Mechanical anchor fasteners shall be of following types:

a) Wedge/ Expansion anchor fasteners

They are most commonly used anchor fasteners and shall be utilized in safety related installations, fixing of insert or base plate for beams & columns, jacking of column, staircase railing, handrails, racks, walkways, pipe supports, ladders, jacketing, platform supports, strengthening of structure, knee supports, fire sprinklers, concrete formwork, telecommunication equipments, etc.

b) Screw anchor fasteners

They shall be used for installation of door & window frames, fences, facade panels, cable trays, electrical fixtures, hangers, sill plates, Signages, temporary fabrications, formwork props, Tilt ups & Prefab connectors, etc.

c) Undercut anchor fasteners

They shall be used only for critical applications with prior design assistance from the manufacturer, like for fixing pumps, turbines, industrial exhaust fans, heavy pipes, crane rails, crash & safety barriers, industrial machines, heavy platform supports, knee brackets with heavy loads, supports subjected to cyclic/dynamic loadings (shock, seismic & fatigue), etc.

11.2.2 Mechanical anchor fasteners shall be designated as medium and heavy duty depending on their usage. The broad classification is given below for general guidance.

11.2.2.1 Medium Duty for:

- a) Ladders, balconies and stairs support.
- b) Cables and cable trays support.
- c) Electrical panels and fixtures.
- d) Hangers for pipes and cable trays
- e) Secondary & tertiary Pipe supports.
- f) Equipment Skids
- g) Formwork props, tilt ups and prefab connectors.
- h) Small Industrial equipments.

11.2.2.2 Heavy Duty for:

- a) Platform supports (beam and columns)
- b) Knee brackets for pipes/ multi tiers cable trays/ walkways etc.
- c) Foundation anchors for heavy equipment like boiler, silos, etc.
- d) Primary connection for erection of Beams & Columns for missing insert/ base plates
- e) Primary pipe supports, Industrial machines
- f) Safety barriers, Crash barriers, Crane rails, dorm structures
- g) Elevator tracks, Car hoists, roof & slab supports

11.2.3 Necessary support shall be taken from the Manufacturer while deciding the Mechanical anchor fasteners for following applications:

- a) Members supporting equipment and pipes subjected to vibrations.
- b) Cantilever connections designed to cater for effective cantilever spans greater than 1m and concentrated load of more than 10KN at the free end.

11.3 Selection

The Contractor shall procure the Mechanical anchor fasteners from the approved manufacturers as per Departmental List of Approved Manufacturers.

11.4 Testing

If so desired by the Engineer-in-Charge, the Contractor shall carry out all the requisite tests (pullout test, torque test etc.) of specimen Mechanical anchor fasteners (representative of those to be used) from approved laboratory/ test house and submit the report to him for approval. The decision of the Engineer-in-Charge regarding the adequacy of strength and load carrying capacity of Mechanical anchor fasteners shall be final and binding to all. The cost of all such tests shall be borne by the Contractor.

11.5 Installation

The Contractor shall install Mechanical anchor fasteners at their correct location (to suit the requirement of fixtures as shown in drawings) as per the procedure laid down by the manufacturer. Location of all holes shall be pre-marked on the concrete surfaces. Scanning before drilling shall be done with appropriate ferro scanner tool to avoid rebar hits and structural damage. The holes shall then be drilled carefully with an electric drill to the correct recommended size and depth. Holes shall be exactly round and true perpendicular to the concrete surface. Edge distance and pitch of fasteners shall be as recommended by the manufacturer. The contractor shall suitably shift the hole with the approval of the Engineer-in-Charge in case any reinforcement bar is encountered while scanning/ drilling the hole in RCC structure. Anchors shall preferably be driven with the help of setting tool, fixed at right embedment depth, by applying torque using calibrated impact wrench as per manufacturer's instructions. Necessary staging shall be provided for working and the Contractor shall take requisite safety precautions so as not to cause any damage to the existing structure/ equipment. Any damage done while executing the job shall be made good by the Contractor at his own cost.

11.6 Protection

The exposed surfaces of Mechanical anchor fasteners shall be properly greased & covered with jute cloth so as to protect them from damage.

11.7 Payment

Payment for installing rust proof Mechanical anchor fasteners shall be made on number basis (each). The rate shall include supply of complete assembly, handling, transporting, providing necessary temporary staging, installing (as per manufacturer's specifications) in PCC/ RCC structures, at all levels and locations, testing, scanning, drilling, cleaning, covering with jute cloth, relocating and re-drilling in case of any obstruction, making good any damage done to the structure, grouting the abandoned holes and any gap left between the contact surfaces of PCC/ RCC and fixtures to be added, design assistance from the Manufacturer (wherever required), etc. all complete.

12.0 CHEMICAL ANCHOR FASTENERS AND DOWELS (REBARS)

Design and testing of Chemical anchor fasteners including Adhesive (Chemical) shall conform to IS 1946 Part-2 & Part-3 respectively or they shall be approved by European Organization for Technical Approval (EOTA)/Centre Scientifique et Technique du Bâtiment (CSTB)/ Code Officials and Laboratory Accreditation (COLA)/ International Code Council-Evaluation Services (ICC-ES formerly ICBO-ES) for use in Cracked Concrete. They shall

have Seismic (Zone III & above equivalent), Fatigue, Shock and Fire approvals from European Technical Assessment (ETA) agency.

The adhesive (Chemical) shall have an ETA approval for 100 years of age testing and shall comply with EOTA Technical Report (TR 029)/ EN 1992-4 while using with Chemical anchor fasteners and EOTA Technical Report (TR 069) & European Assessment Document (EAD 332402-00-0601) while using with Dowels (Rebars).

Design of post-installed Chemical anchor fasteners and Dowels (Rebars) shall be provided/ verified by the approved manufacturer with installation instructions and execution shall be done by an applicator trained by the approved manufacturer (preferably in the presence of manufacturer for critical applications/ structures).

12.1 Material

Chemical anchor fasteners shall be of high tensile steel rods of minimum grade 5.8 galvanised to at least 5 microns or Stainless Steel (SS304 or SS316) and shall be approved for use in cracked concrete.

Stainless steel Chemical anchor fasteners shall be preferred for sites located in coastal areas or in high rainfall zone.

Rebars used as dowels shall be of grade as per General Notes of the project.

12.2 Selection

The Contractor shall select the chemical anchor fasteners based on the parameters such as Loads and rebars for dowels as specified in the AFC drawings/ documents. The chemical anchor fasteners shall be procured from the approved manufacturers as per Departmental List of Approved Manufacturers.

12.3 Testing

The Contractor shall carry out, at the work place, the requisite tests like pull out test, shear test, etc. for chemical anchor fasteners and pull out test for dowels (rebars). The chemical anchor fasteners shall withstand the load specified in the drawing/ documents and the Dowels (rebars) shall be tested for full tensile capacity of the rebars. The decision of the Engineer-in-Charge regarding the adequacy of strength and load carrying capacity of the anchor fasteners/ dowels (rebars) shall be final and binding to all. The cost of all such tests shall be borne by the Contractor.

12.4 Installation

The Contractor shall install the chemical anchor fasteners/ dowels (rebars) at their correct location (to suit the requirement of fixtures as shown in drawings) as per the procedure laid down by the manufacturer. Location of all holes shall be pre-marked on the concrete surfaces. Scanning before drilling shall be done with appropriate ferro scanner tool to avoid rebar hits and structural damage. The holes shall then be drilled carefully with an electric drill to the correct recommended size and depth. Holes shall be exactly round and true perpendicular to the concrete surface. Edge distance and pitch of fasteners shall be as recommended by the manufacturer. The contractor shall suitably shift the hole with the approval of the Engineer-in-Charge in case any reinforcement bar is encountered while scanning/ drilling the hole in RCC structure. The adhesive (chemical) shall preferably be dispensed with the help of battery operated dispenser gun & mixer nozzle to avoid over/ under dosing & void creation. Piston plugs and extension pipe shall be used for embedment depths beyond 300 mm. Anchors shall preferably be driven with the help of setting tool,

fixed at right embedment depth, by applying torque using calibrated impact wrench as per manufacturer's instructions. Necessary staging shall be provided for working and the Contractor shall take requisite safety precautions so as not to cause any damage to the existing structure/ equipment. Any damage done while executing the job shall be made good by the Contractor at his cost.

12.5 Payment

Payment for installing chemical anchor fasteners shall be made on number basis (each). The rate shall include supply of complete assembly i.e. chemical anchor fasteners along with adhesive (chemical) foils as per manufacturer specifications.

Payment for installing chemical dowels (rebars) shall be made on number basis (each). The rate shall include fixing of dowels (rebars) by drilling/ cleaning hole and injecting odourless adhesive (chemical) as per manufacturer specifications. Rebars used as dowels shall be paid separately under relevant SOR item.

For chemical anchor fasteners/ dowels (rebars), the rate shall be inclusive of handling, transporting, providing necessary temporary staging, installing (as per manufacturer's specifications) in PCC/ RCC structures to a required depth with a specified hole diameter, at all levels and locations, testing, scanning, drilling holes, cleaning, covering with jute cloth, relocating and re-drilling in case of any obstruction, making good any damage done to the structure, grouting the abandoned holes and any gap left between the contact surfaces of PCC/ RCC and fixtures to be added, design assistance from the Manufacturer (wherever required), etc. all complete.

मानक विनिर्देशन
सिविल एवं संरचनात्मक कार्य

STANDARD SPECIFICATION
CIVIL & STRUCTURAL WORKS

ईट की चिनाई

BRICK MASONRY

6	11.12.25	REVISED & REISSUED AS STANDARD SPECIFICATION	<i>Ch</i> Chandan	<i>Amye</i> Amarjeet	<i>AS</i> Anurag Sinha	<i>M.Nandi</i> M.Nandi
5	21.12.20	REVISED & REISSUED AS STANDARD SPECIFICATION	AS	RBS	AS	SM
4	10.03.16	REVISED & REISSUED AS STANDARD SPECIFICATION	MK	AJS	RS	S Chanda
3	14.05.10	REVISED & REISSUED AS STANDARD SPECIFICATION	YPC	PKM	SC	N Duari
2	06.04.00	REAFFIRMED & ISSUED	SBJ	SKP	SCJ	MI
Rev. No	Date	Purpose	Prepared by	Checked by	Standards Committee Convenor	Standards Bureau Chairman
						Approved by

Abbreviations:

ASTM	:	American Society for Testing and Materials
BIS	:	Bureau of Indian Standards
IS	:	Indian Standards

Structural Standards Committee:

Convener: Mr. Anurag Sinha

Members: Mr. Virender Goel
Mr. Deepak Agrawal
Ms. Alpana Srivastava
Dr. Sudip Paul
Ms. Papia Mandal
Mr. Vikram Kumar Gupta
Mr. Charanjit Singh (Projects)
Mr. Indrajit Neog (Construction)

CONTENTS

1.0	SCOPE.....	4
2.0	REFERENCES	4
3.0	MATERIALS	4
4.0	GENERAL REQUIREMENTS.....	4
5.0	CONSTRUCTION PROCEDURE.....	5
6.0	PAYMENT.....	9

1.0 SCOPE

This specification establishes the materials, dressing, laying, joining, curing, workmanship etc. for brick masonry works. Brick masonry shall also comply with all the requirements of IS 2212.

2.0 REFERENCES

2.1 Standards

S. No.	IS No.	Title
1.	IS 2212	Brick work- code of practice
2.	IS 2250	Code of practice for preparation and use of Masonry mortars
3.	IS 2750	Specification for Steel Scaffoldings
4.	ASTM C 1714	Standard Specification for Preblended Dry Mortar mix for unit masonry

2.2 EIL specification

6-68-0002: Materials

3.0 MATERIALS

Refer EIL Specification No. 6-68-0002.

4.0 GENERAL REQUIREMENTS

4.1 Cement Mortar

Cement mortar shall meet the requirements of IS 2250 and shall be prepared by mixing cement and sand by volume. Proportion of cement and sand shall be 1:6 (1 part of cement and 6 parts of sand), or as directed by the Engineer-in-Charge/shown on the drawing, for brick masonry of one brick thickness or more, while 1:4 cement mortar (1 part of cement and 4 parts of sand) shall be used for brick masonry of half brick thickness. The sand being used for mortar shall be sieved. The mortar shall be used as soon as possible after mixing and before it has begun to set and in any case within initial setting time of cement after water is added to the dry mixture. Mortar unused for more than initial setting time of cement, shall be rejected and removed from the site of work.

4.1.1 Proportioning

The unit of measurement for cement shall be a bag of cement weighing 50 Kg and this shall be taken as 0.035 cubic metre. Sand shall be measured in boxes of suitable size on the basis of its dry volume. In case of damp sand, its quantity shall be increased suitably to allow for bulkage.

4.1.2 Mixing

The mixing of mortar shall be done in a mechanical mixer operated manually or by power. The Engineer-in-Charge may, however, permit hand-mixing as a special case, taking into account the magnitude, nature and location of work. The Contractor shall take the prior

permission of Engineer-in-Charge, in writing, for using hand-mixing before the commencement of work.

4.1.2.1 Mixing in Mechanical Mixer

Cement and sand in specified proportions, by volume, shall be thoroughly mixed dry in a mixer. Water shall then be added gradually and wet mixing continued for atleast one minute. Care shall be taken not to add more water than that which shall bring the mortar to the consistency of stiff paste. Wet mix from the mixer shall be unloaded on water-tight masonry platform, made adjacent to the mixer. Platform shall be atleast 150 mm above the levelled ground to avoid contact of surrounding earth with the mix. Size of the platform shall be such that it shall extend atleast 300mm around the loaded wet mix area. Wet mix, so prepared, shall be utilised within initial setting time of cement after addition of water. Mixer shall be cleaned with water each time before suspending the work.

4.1.2.2 Hand Mixing

The measured quantity of sand shall be levelled on a clean water-tight masonry platform and cement bags emptied on top. The cement and sand shall be thoroughly mixed dry by being turned over and over, backward and forward, several times till the mixture is of uniform colour. The quantity of dry mix which can be consumed within initial setting time of cement shall then be mixed with just sufficient quantity of water to bring the mortar to the consistency of stiff paste.

4.2 Ready mix Preblended Mortar

Packaged ready to use preblended dry mortar mix conforming to ASTM C 1714 or equivalent shall also be used for joining the masonry units with prior approval of Engineer-in-Charge.

4.2.1 Ingredients

Ready mix preblended mortar package shall consist of cement, graded sand, flyash, additive polymers or a combination thereof as per manufacturer's specification.

4.2.2 Mixing

The dry ready mix mortar shall be added to an appropriate amount of potable water (not vice-versa) as per manufacturer's recommendation. Mixing shall be done slowly by using manual/ electrical stirrer to form a uniform paste free from lumps. The paste shall be kept undisturbed for few minutes as specified allowing ingredients to react properly. The paste shall then be applied in specified thickness within the time limit as per manufacturer's recommendation.

5.0 CONSTRUCTION PROCEDURE

5.1 Soaking of Bricks

Bricks shall be soaked in water before use for a period that is sufficient for the water to just penetrate the whole depth of bricks as well as to remove dirt, dust and sand. Proper soaking of bricks shall prevent the suction of water from the wet mortar as otherwise mortar will dry out soon and crumble before attaining any strength. The bricks shall not be too wet at the time of use as they are likely to slip on mortar bed and there will be difficulty in achieving the plumbness of wall as well as proper adhesion of bricks to mortar. The period of soaking shall be determined at site by a field test by immersing the bricks in water for different periods and then breaking the bricks to find the extent of water penetration. The least period

that corresponds to complete soaking, will be the one, to be allowed for in the construction work.

The soaked bricks shall be stacked over a clean place, wooden planks or masonry platforms to avoid earth, dirt being smeared on them. It shall be ensured that at the time of laying of soaked bricks, they are skin dry.

5.2 Laying

5.2.1 Brick Work (one or more brick thickness)

Brick work (one or more brick thickness) shall be laid in English Bond unless otherwise specified. Half or cut bricks shall not be used except when needed to complete the bond. In no case the defective bricks shall be used.

A layer of average thickness of 10mm of cement mortar shall be spread on full width over a suitable length of lower course or the concrete surface. In order to check and achieve uniformity in masonry, the thickness of bed joints shall be such that four courses and three joints taken consecutively shall measure equal to four times the actual thickness of the brick plus 30mm. Each brick with frog upward, shall be properly bedded and set in position by gently tapping with handle of trowel or wooden mallet. Its inside faces shall be buttered with mortar before the next brick is laid and pressed against it. After completion of the course, all vertical joints shall be filled from top with mortar.

All brick courses shall be taken up truly plumb; if battered, the batter is to be truly maintained. All courses shall be laid truly horizontal and vertical joints shall be truly vertical. The level and verticality of work in walls shall be checked up at every one metre interval.

The masonry walls of structures shall be carried up progressively, leaving no part one metre lower than the other. If this cannot be adhered to, the brick work shall be raked back according to bond (and not left toothed) at an angle not more than 45 degrees but raking back shall not start within 60 cm of a corner. In all cases returns, buttresses, counter forts, pillars etc. shall be built up carefully course by course, and properly bonded with the main walls. The brick work shall not be raised more than fourteen (14) courses per day.

At the junction of any two walls, the bricks shall at each alternate course, be carried into each of the respective walls so as to thoroughly unite the work.

The courses at the top of plinth and sills, at the top of the wall just below the soffit of the roof slab or roof beam and at the top of the parapet, shall be laid with bricks on edge. Brick on edge course shall be so arranged as to tightly fit under the soffit of the roof beam or roof slab, restricting the mortar layer thickness upto 12mm. However, any gap between the finished brick work and soffit of roof slab/beam shall be suitably sealed with the mortar.

5.2.2 Brick Work (half brick thickness)

For brick walls of half brick thickness, all courses shall be laid with stretchers. Wall shall be reinforced with 2 nos. - 6mm diameter mild steel bars, placed at every fourth course. The reinforcement bars, shall be straightened and thoroughly cleaned. Half the mortar thickness for the bedding joint shall be laid first and for steel reinforcement, one on each face of the wall, shall be embedded, keeping a side cover of 12mm mortar. Subsequently, the other half of the mortar thickness shall be laid over the reinforcement covering it fully.

The reinforcement bars shall be carried at least 150mm into the adjoining walls or RCC columns. In case the adjoining wall being of half brick thickness, the length of bars shall be

achieved by bending the bars in plan. During casting of reinforced concrete columns, 6mm dia. mild steel bars shall be placed at every fourth course of brick masonry. At the junction of two walls, the brick shall, at each alternate course, be carried into each of the respective walls so as to thoroughly unite the work. The brick masonry work shall not be raised more than 14 courses per day.

Brick course under the soffit of beam or slab, shall be laid by restricting the mortar thickness to 12mm. However, any gap between the finished brickwork and soffit of slab/beam, shall be suitably sealed with the mortar.

5.2.3 Cavity Walls

Brick work in cavity walls shall be similar to general brickwork. It shall consist of one wall of one or more brick thickness while the other wall shall be of half brick thickness at a clear gap of 50mm. The brick work on either side of cavity shall conform to the specifications already as stated in Cl. No. 5.2.1 and 5.2.2. At the base of the cavity wall, the walls shall be solidly constructed upto 300mm above the ground level. The cavity wall shall be terminated 300mm below the soffit of roof slab/beam and the courses over this shall be continued as solid brickwork.

Cavity should be continuous and free from obstructions. Mortar droppings shall be prevented from falling down the cavity by the use of laths or by hayhands which shall be drawn up the cavity as the work proceeds. Any mortar which may unavoidably fall on the wall-ties, shall be removed daily and temporary openings shall be provided to permit the daily removal of mortar droppings from the bottom of the cavity.

The outer and inner leaves shall be tied by means of wall ties. Ties shall be of tor steel bars of 8mm dia. 200 mm long with hooks at both the ends. These shall be placed not more than 750mm c/c horizontally and not more than 300mm vertically, and staggered. Additional ties shall be provided near the openings. There shall at least, be 5 ties per square metre of surface area of the wall. Ties shall be given a bituminous coat before placement, to protect them from corrosion.

In order to keep the cavity dry, air slots shall be provided in the cavity walls at bottom as well as top to the extent of 50 sq.cm area of vents to every 2.0 sq.metre area of the wall.

5.2.4 Circular Brick Work

The detailed specification for brick work covered under clauses 5.2.1 & 5.2.2 shall also apply for circular brickwork. Bricks forming skew backs, shall be dressed or cut so as to give proper radial bearing. Defects in dressing of bricks shall not be covered up by extravagant use of mortar, nor shall the use of chips etc. be permitted.

The circular brick work shall be carried up from both ends simultaneously and keyed in the centre. The bricks shall be flushed with mortar and well pressed into their positions so as to squeeze out a part of their mortar and leave the joints thin and compact. All joints shall be full of mortar and thickness of joints shall be between 5mm and 15mm.

5.3 Jointing

Joints shall be restricted to a width of 10mm with brickwork of any classification. All bed joints shall be normal to the pressure upon them i.e. horizontal in vertical walls, radial in circular brick masonry and at right angles to the face in the battered retaining walls. The vertical joints in alternate courses shall come directly one over the other and shall be truly vertical. Care shall be taken that all the joints are full of mortar, well flushed up. In case no pointing is to be done, cement mortar shall be neatly struck as the work proceeds. The joints

in faces which are to be plastered or pointed shall be squarely raked out to a depth of 12mm while the mortar is still green. The rake joints shall be brushed to remove loose particles. After the day's work, the faces of the brick work shall be cleaned on the same day with wire brush and all mortar droppings removed.

5.4 Curing

Green work shall be protected from rain or any other running water or accumulated water from any source, by suitable means. Masonry work with conventional cement mortar, as it progresses, shall be kept thoroughly wet by sprinkling water at regular intervals, on all faces. Curing shall be done after 24 hours of completion of day's work as per IS 2212.

Curing of masonry work with ready mix preblended mortar is generally not required as the mix contains self curing polymers. However, manufacturer's specification shall be followed.

5.5 Staging/Scaffolding

5.5.1 Staging/scaffolding shall be properly planned and designed by the Contractor. Use of only steel tubes is permitted for staging/scaffolding. Design of staging/scaffolding shall be submitted for approval of the Engineer-in-Charge, before commencement of work.

Single scaffolding having one set of vertical support, shall be used and other end of the horizontal scaffolding member shall rest in a hole provided in the header course. The support shall be sound and strongly clamped with the horizontal pieces over which the scaffolding planks shall be fixed. The holes left in the masonry work for supporting the scaffolding shall be filled and made good with plain cement concrete of grade 1:2:4 (M15) during plastering. Suitable access shall be provided to the working platform area. The scaffolding shall be strong enough to withstand all loads likely to come upon it and shall also meet the requirements specified in IS 2750.

Double scaffolding shall be provided for pillars less than one metre in width or for the first class masonry or for a building having more than two storeys.

Following measures shall also be considered during erection of the scaffolding/ staging:

- a) Sufficient sills or underpinning, in addition to base plates, shall be provided, particularly, where scaffoldings are erected on soft grounds.
- b) Adjustable bases to compensate for uneven ground shall be used.
- c) Proper anchoring of the scaffolding/staging at reasonable intervals shall be provided in each direction with the main structure wherever available.
- d) Horizontal braces shall be provided to prevent the scaffolding from rocking.
- e) Diagonal braces shall be provided continuously from bottom to top between two adjacent rows of uprights.
- f) The scaffolding/staging shall be checked at every stage for plumb line.
- g) Wherever the scaffolding/staging is found to be out of plumb line, it shall be dismantled and re-erected afresh. Efforts shall not be made to bring it in line with a physical force.
- h) All nuts and bolts shall be properly tightened and care shall be taken that all the clamps/couplings are firmly tightened to avoid slippage.

- i) Erection work of a scaffolding/staging, under no circumstance shall be left totally to semiskilled or skilled workmen and shall be carried out under the supervision of Contractor's technically qualified civil engineer.

5.5.2 For smaller works or works in remote areas wooden ballies may be permitted for scaffolding/staging by the Engineer-in-Charge at his sole discretion. The contractor must ensure the safety and suitability of such works as described under clause 5.5.1 above.

5.6 Embedment of Fixtures

All fixtures, pipes, conduits, holdfasts of doors and windows etc. required to be built in walls, shall be embedded in plain cement concrete block of grade 1:2:4 (M15), at the required positions, as the work proceeds.

6.0 PAYMENT

This clause shall apply to Item Rate tender only.

6.1 General

The payment of brick masonry shall be inclusive of all labour, material, scaffolding/staging sampling and testing, soaking of bricks, laying of bricks, raking of joints, cutting of bricks, providing recesses and making rectangular or round openings, sealing the gap between brick masonry and soffit of beam/slab with and including cement mortar/ ready mix preblended mortar, curing, making of masonry platform for unloading the wet mix/ paste, embedding the fittings/fixtures including providing PCC 1:2:4 (M15) etc, all as specified for all heights and depths. Deduction for rectangular or circular openings shall be done as per relevant BIS Codes.

- 6.1.1 Payment for brick masonry works of one or more brick thickness, including circular brickwork, shall be made on cubic metre basis of the work done.
- 6.1.2 Payment for half brick masonry work shall be made on square metre basis on the area of work done and shall also include the cost of supplying and fixing of reinforcement bars in position.
- 6.1.3 Payment for forming the cavity shall be in square metres and shall include the cost of laying of bitumen coated tor steel ties in position, labour required for keeping the cavity clear, providing air slots etc.

मानक विनिर्देशन
सिविल एवं संरचनात्मक कार्य
STANDARD SPECIFICATION
CIVIL & STRUCTURAL WORKS
गिराने एवं तोडने सम्बंधी कार्य
DEMOLITION AND DISMANTLING

6	03.04.25	REAFFIRMED & REISSUED	AD	MM	AS	MN
5	13.05.19	REAFFIRMED & REISSUED	TK	AS	RS	RKT
4	18.11.13	REVISED & ISSUED AS STANDARD SPECIFICATION	AJS	RS	PKM	SC
3	10.06.08	REAFFIRMED & REISSUED	PKB	PKM	VK	VC
2	25.04.01	REVISED & ISSUED AS STANDARD SPECIFICATION	SKP	RS	SCJ	MI
1	16.03.98	REVISED & ISSUED AS STANDARD SPECIFICATION	SARITA	SKP	SCJ	AS
0	AUG'89	ISSUED AS STANDARD SPECIFICATION		AKV	GPL	RCPC
Rev. No	Date	Purpose	Prepared by	Checked by	Standards Committee Convenor	Standards Bureau Chairman
Approved by						

Abbreviations:

C&D	:	Construction & Demolition
GI	:	Galvanized Iron
RA	:	Recycled Aggregates
RCC	:	Reinforced Cement Concrete
PCC	:	Plain Cement Concrete

Structural Standards Committee

Convenor : Mr. Anurag Sinha

Members : Mr. Virender Goel
Mr. Deepak Agrawal
Mr. VK Panwar
Mr. Amitabh Kishore
Mr. Gyasuddin
Mr. Ravindra Kumar (Const.)
Mr. Charanjit Singh (Proj.)

CONTENTS

1.0	SCOPE	4
2.0	GENERAL	4
3.0	SAFETY PRECAUTIONS	4
4.0	PROCEDURE	5
5.0	CLEANING & STACKING	5
6.0	DISPOSAL	5
7.0	C&D WASTE MANAGEMENT	6
8.0	PAYMENT	6

1.0 SCOPE

This specification covers the procedure and safety requirements for demolition and dismantling of masonry (Brick & Stone), concrete (Plain /Reinforced), structural steel (covered/ open) works.

2.0 GENERAL

- 2.1 Apart from this specification, the demolition and dismantling of structures (part or whole) shall be in compliance with all statutory safety regulations and any other special requirement as shown/ noted on the drawings and General Conditions of Contract. Prior consent and approval of the Engineer-in-Charge shall be obtained in writing before starting any dismantling works. Any restrictions imposed regarding working hours shall also be strictly followed by the Contractor.
- 2.2 All materials obtained from dismantling/demolition operations shall be the property of the Owner unless otherwise specified and shall be segregated as serviceable or unserviceable materials and kept in safe custody until handed over to the Engineer-in-Charge.
- 2.3 Contractor shall follow the principle of selective demolition by sequencing the demolition activities in such a way that the non-structural materials like window/ door frames, pipes, tiles, bricks, asphalt, ceramics, etc. shall be removed first before starting the main demolition activities.
- 2.4 Where it becomes necessary to disconnect any existing service line(s) (such as electrical, piping etc.) during dismantling/demolishing operation and where so required by the Engineer-in-Charge, suitable alternate arrangement shall be made by the Contractor to maintain the continuity and proper functioning of the affected service line(s) with the approval of the Engineer-in-Charge at no extra cost to the Owner.
- 2.5 Specification No. 6-68-0003 (Earthwork) shall be referred to the extent applicable.

3.0 SAFETY PRECAUTIONS

- 3.1 The Contractor shall adhere to safe demolishing/ dismantling practice at all stages of work to guard against accidents, hazardous and unsafe working procedures.
- 3.2 Necessary propping, shoring, strutting and/or underpinning shall be done for the safety of all surrounding structures (whose safety is likely to be endangered) before taking up the demolishing and dismantling works.
- 3.3 Temporary enclosures/ barricading made out of GI sheets, fencings, danger lights, warning tapes, etc. shall be provided by the Contractor and got approved by the Engineer-in-Charge before start of work to prevent accidents.
- 3.4 Contractor must ensure the availability of adequate fire fighting equipments/ arrangements before starting actual demolishing/ dismantling works. These facilities shall be made available throughout the entire operation of demolition and dismantling of structures.
- 3.5 All equipments, pipes, fittings and instruments, underground utilities etc. located in the vicinity shall be protected by suitable means, as decided by the Engineer-in-Charge, during demolishing/ dismantling operations.
- 3.6 Roads and working spaces shall be kept free of any debris/dismantled materials at the end of day's work.

- 3.7 Necessary measures shall be taken to keep the dust and noise nuisance to minimum levels.
- 3.8 Dismantled elements/components shall not be dropped from a height or thrown from a distance. Dismantling of elements fixed by screws/bolts/hooks etc. shall be done by taking out the fixtures with proper tools only. Such fixtures may be allowed to be cut by sawing or flame cutting, in the event of their being stuck up due to corrosion etc. However, the decision of Engineer-in-Charge in this regard shall be final and binding. Welds shall be removed by flame cutting. Tearing or ripping of elements shall not be resorted to under any condition.
- 3.9 Dismantling of equipments/ instruments and such other fixtures shall be done with utmost care with proper tools & tackles and shall be stacked separately. Their disposal or retainment shall be as per the directions of Engineer-in-Charge.

4.0 PROCEDURE

- 4.1 Entire work of demolishing & dismantling shall be meticulously planned. Prior to start of work, the Contractor shall thoroughly understand the scope and nature of the work, and then prepare and submit the proposed work execution plan of demolishing & dismantling to the Engineer-in-Charge for his review. Comments if any, shall be taken care by the contractor and execution of the work shall be done based on the revised execution plan.
- 4.2 Demolition and dismantling shall be restricted to the extent shown on drawings or as directed by the Engineer-in-Charge.
- 4.3 Necessary work permits (as applicable) shall be obtained prior to start of demolishing/ dismantling activities.
- 4.4 Demolition of any structure shall be carried out in the sequence reverse to that followed at the time of its construction.
- 4.5 Dismantling shall be done in a systematic manner. All elements including equipments/ instruments shall be carefully removed without causing any damage.
- 4.6 Blasting in any form shall not be permitted. However, techniques like pneumatic/ hydraulic breakers, diamond cutting, etc. shall be utilized to the maximum possible extent.
- 4.7 Chipping of concrete/grout shall be done with precision by chiseling. The finished surfaces shall be made true to the requisite size and shape.
- 4.8 Pockets/holes of specified size shall be made/ cut by drilling/ chiseling/ core cutting/ diamond cutting, etc.
- 4.9 Cut-outs in RCC Slab/ wall shall be made by vibration-less spark-free mechanical means like core-cutting, wet cutting by diamond wall saw system, etc.

5.0 CLEANING & STACKING

All demolished/dismantled serviceable materials such as bricks, stones, reinforcement bars, structural steel, sheeting etc. shall be separated out, cleaned and stacked in separate lots within the plant boundary as directed by the Engineer-in-Charge.

6.0 DISPOSAL

All unserviceable materials shall be disposed off in spoil heaps within or outside the plant boundary as per the directions of the Engineer-in-Charge. Areas required outside the plant boundary for dumping of disposed material shall be arranged by the contractor and got approved by the Engineer-in-Charge.

- 8.5.1** Payment for Pockets/ holes shall be made on the basis of number (Each) of pockets/ holes of sizes upto & inclusive of 200x200x500mm deep, made or cut in the concrete works at all depths & heights.
- 8.5.2** Payment for cut-outs in RCC slab/ wall shall be made in CuM on the basis of plan/ elevation area for a thickness upto & inclusive of 400mm at all depths & heights.
- 8.5.3** The rate for making pockets/holes and cut-outs shall include supply of all labour, tools & tackles, necessary safety measures, scaffolding, chiseling, drilling, core/ diamond cutting, diamond wall saw system, handling, cutting or relocating reinforcement bars, cleaning, disposal of all unserviceable material etc. all complete as directed.
- 8.6 Dismantling of Structural Steel Works**
- 8.6.1** Payment shall be made on the basis of weight (MT) of the structure/components being dismantled. Assessment of weight shall be done as per the specifications or as per the direction of Engineer-in-Charge.
- 8.6.2** The rate for dismantling shall include supply of all labour, tools and tackles, equipment, consumables, necessary safety measures, scaffolding, propping, handling, unbolting, cutting (by sawing or flame cutting) of gussets/ plates/ bolts/ hooks/ welds, cleaning, sorting out and stacking of all serviceable materials, disposal of all unserviceable material, etc. all complete as specified and directed.
- 8.7 Dismantling of Roof & Wall Sheeting**
- 8.7.1** Payment shall be made on the basis of dismantled sheeted area in square metres (sq.m.) of plan area in case of roof sheeting and area in elevation in case of side and louver sheeting.
- 8.7.2** The rate for dismantling shall include supply of all labour, tools and tackles, equipments, consumables, necessary safety measures, handling, scaffolding, unbolting, cutting (by saw or flame cutting) of hook bolts, removal of ridges, gutters, flashings, transporting, stacking of all serviceable materials, disposal of all unserviceable material, etc. all complete as directed.

मानक विनिर्देश
सिविल एवं संरचनात्मक कार्य
विविध मदें

STANDARD SPECIFICATIONS
CIVIL AND STRUCTURAL WORKS
MISCELLANEOUS ITEMS

6	13.03.25	REVISED & REISSUED	TARUN KAPOOR	AMARJEET	ANURAG SINHA	MAINAK NANDI
5	24.01.22	REVISED & REISSUED	TARUN	AMARJEET	ANURAG SINHA	S.MAZUMDAR
4	22.03.16	REVISED & REISSUED	MODITA	ALPANA	R.SRIVASTAVA	S.CHANDA
3	29.06.10	REISSUED	AS	PKM	SCH	N DUARI
2	26.04.01	UPDATED & REISSUED	SBJ	R SOOD	SC JAIN	MI
1	AUG 94	UPDATED & REISSUED	SBJ	R SOOD	GPL	A SONI
0	AUG 89	ISSUED AS STANDARD SPECIFICATION	-	AKV	GPL2	RPCP
Rev. No	Date	Purpose	Prepared by	Checked by	Standards Committee Convenor	Standards Bureau Chairman

Abbreviations:

BIS	:	Bureau of Indian Standards
DPC	:	Damp Proof Course
FGL	:	Finished Ground Level
IS	:	Indian Standard
RCC	:	Reinforced Cement Concrete

Structural Standards Committee

Convenor: Mr. Anurag Sinha

Members: Mr. Virender Goel
Mr. Deepak Agrawal
Ms. Alpana Srivastava
Dr. Sudip Paul
Ms. Papia Mandal
Mr. Vikram Kumar Gupta
Mr. Charanjit Singh (Projects)
Mr. Indrajit Neog (Construction)

CONTENTS

1.0	SCOPE	4
2.0	REFERENCES	4
3.0	MATERIALS	4
4.0	GENERAL REQUIREMENTS.....	4
5.0	PRE-CONSTRUCTIONAL ANTI-TERMITE TREATMENT	4
6.0	ANTI-CORROSIVE LAYER	6
7.0	DRESSING & TRIMMING.....	7
8.0	BREAKING PILE HEADS.....	7
9.0	BUILDING-UP PILE HEADS.....	7
10.0	HARD CORE	8
11.0	SAND FILLING IN PLINTH/FOUNDATIONS.....	9
12.0	DAMP PROOF COURSE (DPC)	9

1.0 SCOPE

The scope shall be as specified separately for different items below.

2.0 REFERENCES

2.1 BIS Codes

IS:73 : Paving bitumen - specification

IS:383 : Specification for coarse and fine aggregates from natural sources for Concrete

IS:6313 : Code of practice for Anti-termite measures in buildings

2.2 EIL specifications

6-68-0002: Materials

6-68-0004: Plain and Reinforced Cement Concrete

3.0 MATERIALS

The materials shall be as specified separately for different items below.

4.0 GENERAL REQUIREMENTS

The Contractor shall test the materials, wherever applicable, in approved laboratory as required by the Engineer-in-Charge and furnish test certificates for materials and obtain the approval of the Engineer-in-Charge prior to the use of such materials in the works. All tests shall be in accordance with relevant Indian Standards.

5.0 PRE-CONSTRUCTIONAL ANTI-TERMITE TREATMENT

5.1 Scope

This specification establishes the materials and method of accomplishing pre-constructional anti-termite treatment of soil for protection of buildings against attack by subterranean termites with the usage of chemical emulsions in accordance with the procedure laid down.

5.2 Materials

Refer EIL Specification No. 6-68-0002.

5.3 Procedure for Treatment

5.3.1 Anti-termite chemicals have an adverse effect upon health when absorbed through the skin, inhaled as vapours or spray mist or swallowed. Applicators shall wear appropriate Personal Protective Equipments (PPEs) and exercise due precautions in handling these chemicals while preparing solution and carrying out soil treatment.

The storage and application of anti-termite compounds shall be carried out by a trained professional agency possesses a valid license issued by the respective State/ Central government department of Agriculture as required under the Insecticides Act and the Rules framed thereunder. Necessary documents shall be submitted by the Contractor to the Engineer-in-Charge for review and approval.

Apart from this specification, the work shall be carried out in compliance with IS:6313. In case of any contradiction, this specification shall govern.

5.3.2 Site Preparation

Prior to start of Anti Termite treatment, area(s) shall be made free from logs, stumps, timber offcuts, leveling pegs, roots of plants/ trees etc. Soil treatment shall start when foundation trenches/ pits are ready to take concrete/ masonry in foundations and plinth area ready for laying the subgrade. Treatment shall not be carried out when it is raining or the subsoil water level is at the same or higher than the level of treatment. In the event of water-logging of foundations, the water shall be pumped out and the chemical emulsion applied when the soil is absorbent.

5.3.3 Treatment of the excavated pits/ trenches and backfill for Foundations

- a) The bottom surface and the lower 300 mm side surfaces of the excavated pits/ trenches for foundations of masonry works and RCC plinth beams supporting such masonry works, shall be treated with specified chemical emulsion @ 5 litres/m² of the surface area. However, no such treatment shall be required in case of pits/ trenches made for RCC foundations supporting RCC walls and/ or columns.
- b) On completion of construction of masonry foundations, the backfill in immediate contact with the substructure shall be treated in layers, of 300 mm, with emulsion @ 7.5 litres/m² of the vertical surface of the substructure (i.e. $7.5 \times 0.3 = 2.25$ litres/meter of perimeter) for each side. The treatment shall be given after ramming of each layer of soil, by rodding the earth at 150 mm centres close to the wall surface and working the rod backward and forward (parallel to the wall surface) and then spraying the specified dosage of emulsion. The emulsion shall be directed towards the masonry surfaces so that the soil in contact with these surfaces is well treated with the chemical. After the treatment, the soil shall be tamped back into place. This shall be done for full depth of the fill.
- c) For RCC walls and columns, the treatment as specified in (b) shall start from a depth 500 mm below the finished ground level, and shall be done upto the FGL.

5.3.4 Treatment of Plinth/ Basement and Apron

- a) The top surface of the consolidated earth below the non-suspended floor slabs and the peripheral aprons of widths upto 750 mm, the bottom surface and side surfaces of the excavated pits for the basements shall be treated with chemical emulsion @ 5 litres/m² of the surface area. Holes 50 mm to 75 mm deep at 150 mm centre, both ways, shall be made on the surface with 12 mm diameter mild steel rod and then emulsion shall be sprayed uniformly over the area. At expansion joint locations, anti-termite treatment shall be supplemented by treating through the expansion joint @ 2.0 litres per linear metre of joint after the sub-grade has been laid.
- b) Treatment of Junctions of plinth filling and wall/column faces shall be done after making a small channel 30 mm x 30 mm, by making rod holes 150 mm apart (upto the ground level) in the channel and then by moving the rod backward and forward to break up the earth. The chemical emulsion shall be poured along the channel @ 7.5 litres/m² of the vertical wall/column surface so as to soak the soil right to the bottom. The soil shall be tamped back into place after the treatment.

5.3.5 Treatment of Soil along External Perimeter of Building

After the building is complete, the earth along the external perimeter shall be rodded at intervals of 150 mm and to depth of 300 mm. The rod shall be moved backward and forward parallel to the wall to break up the earth and chemical emulsion poured along the

wall @ 7.5 litres/m² of vertical surface (i.e. 7.5 x 0.3 = 2.25 litres/metre of perimeter). After the treatment, the earth shall be tamped back into place.

5.4 Guarantee

A Guarantee of minimum 10 years shall be provided by the contractor against the performance of the Anti-termite treatment.

5.5 Payment

This clause shall apply to Item Rate tender only.

Payment for pre-constructural anti-termite treatment shall be made on square metre (sq.m.) basis of plinth area of the building at ground floor only.

The rate shall include supplying all materials, spray pumps, tools, tackles & other accessories, labour, site preparation, rodding, tamping, mixing, spraying the specified chemical emulsion at prescribed dosage, storage facilities, handling, transporting etc. all complete as directed & specified.

6.0 ANTI-CORROSIVE LAYER

6.1 Scope

This specification covers the requirement of materials, method of preparation and procedure for laying an anticorrosive layer over top surface of tank foundations for protection of bottom plates of steel tanks against corrosion attack.

6.2 Materials

6.2.1 Sand shall be clean, dry, coarse, hard, angular, free from coatings of clay, dust and mix of vegetable and organic matter and shall conform to IS:383 - Grade III.

6.2.2 Bitumen shall be of grade VG10 conforming to IS:73.

6.3 Mixing and Laying

The bitumen shall be heated till it melts. 3% kerosene may be added if required. Sand shall be thoroughly mixed with bitumen (8% to 10% by volume) in a mixing drum to give a uniform mixture and shall be laid over clean and dry surface of tank foundation to line, grade and levels as shown on the drawings and directed by the Engineer-in-Charge. Bitumen shall not be heated beyond the specified temperature limits. The layer shall be tamped to form hard mass of specified compacted thickness.

6.4 Payment

This clause shall apply to Item Rate tender only.

The payment shall be made on square metre (sq.m.) basis of the area covered with the anticorrosive layer.

The rate shall include supplying all materials, tools, plants, labour, transportation, handling, heating, mixing, laying, tamping etc. all complete as specified.

7.0 DRESSING & TRIMMING

7.1 Scope

This specification covers the procedure for dressing, trimming and paving with earth the peripheral area around the completed building/ structure.

7.2 Procedure

The ground all around the completed building/structure for 3 metres width or as specified by the Engineer-in-Charge, shall be cleaned and dressed to suitable slope. Over the prepared ground a layer of approved earth shall be spread, watered and well consolidated so as to achieve an average thickness of 75 mm.

7.3 Payment

This clause shall apply to Item Rate tender only.

Payment shall be made on square metre (sq.m.) basis of the actual area dressed and paved with earth.

The rate shall include supplying all materials, labour including cleaning, dressing the ground to required slope, spreading of earth, watering, ramming, consolidating etc. all complete as directed.

8.0 BREAKING PILE HEADS

8.1 Scope

This specification covers procedure for breaking pile heads of RCC piles.

8.2 Procedure

8.2.1 Head of already cast/ driven RCC piles shall be broken after 28 days of casting up to a length and elevation as shown on the drawing by chiseling or by approved mechanical means taking all necessary safety precautions. Care shall be taken that pile reinforcement is not cut or damaged during chiseling operation. All debris and loose or cracked concrete in the pile shall be removed and disposed off within the plant boundary as per the directions of the Engineer-in-Charge and site shall be left clean for casting of pile caps. The surface of reinforcement bars shall be cleaned, if required by wire brushing, so that no old concrete sticks to them.

8.3 Payment

This clause shall apply to Item Rate tender only.

Payment shall be made per pile basis for the actual number of pile heads broken.

The rate shall include supplying all tools and tackles, labour including disposal of debris, bending the pile reinforcements for proper anchorage within the pile cap etc. all complete as directed.

9.0 BUILDING-UP PILE HEADS

9.1 Scope

This specification covers requirements of materials and procedure for building-up of RCC Pile Heads.

9.2 Materials

9.2.1 Concrete shall be of the same grade & EIL specification shall be same as that for the pile.

9.2.2 Reinforcement shall be of the same grade as that for the pile.

9.2.3 Type of cement shall be same as that used for the pile.

9.3 Procedure

Concrete in existing piles shall be chiseled off minimum upto the lap-length of the reinforcements in the pile. In cases where reinforcements are longer than the concreted piles, the top concrete of the existing piles shall be chiseled or by approved mechanical means upto a length of 800 mm.

Concrete surface and reinforcement of pile shall be cleaned of any dirt, grease, debris etc. and concrete surface shall be made rough by hacking. Reinforcement shall be lapped/ welded as per the direction of the Engineer-in-Charge. Neat cement slurry shall be applied on top surface of concrete and using approved formwork, concreting shall be done upto the level shown on the drawing and as directed by the Engineer-in-Charge.

9.4 Payment

This clause shall apply to Item Rate tender only.

Payment shall be made on cubic metre basis for the total quantity of concrete actually poured for achieving the level as shown on drawings.

The rate shall include supply of all materials (except reinforcement which shall be paid separately as per respective item) labour, cleaning, welding, shuttering, vibrating, finishing, curing etc. all complete. Cutting of pile heads and excavation including backfilling shall be paid separately as per respective item.

10.0 HARD CORE

10.1 Scope

This specification covers the requirements of materials and procedure for laying of hard core.

10.2 Materials

Hard core shall consist of broken/ crushed stones of 150 mm and down size. Stones shall be sound, angular, hard and free from flakes, dust and other impurities.

10.3 Procedure

Hard core shall be laid to the grade, level and thickness as shown on the drawing. Broken stones of required height shall be vertically placed and blinded with approved murrum/ sand and consolidated with roller including watering, dressing etc. However, areas inaccessible by roller may be compacted by hand rammer.

10.4 Payment

This clause shall apply to Item Rate tender only.

The hard core shall be measured on the basis of volume in cubic metres (cu.m.) of the compacted hard core laid. The rate shall include all labour, materials, consolidation by rammer/ roller, watering, dressing etc. all complete.

11.0 SAND FILLING IN PLINTH/FOUNDATIONS

11.1 For specification of sand to be used for filling, reference shall be made to EIL Specification No. 6-68-0002.

11.2 Filling shall be carried out in layers not exceeding 150 mm and shall be compacted mechanically or by saturation to specified grade and level and to obtain 90% laboratory maximum dry density or as specified in schedule of rates.

11.3 Compaction by flooding may be accepted at the discretion of the Engineer-in-Charge, provided the required compaction is achieved.

11.4 The Contractor shall not commence filling in and around any work until it has been permitted by the Engineer-in-Charge.

11.5 Payment

This clause shall apply to Item Rate tender only.

Payment shall be made on cubic metre (cu.m.) basis of the finished compact volume. The rate shall include cost of sand for any compacted thickness, wastage if any, all handling, transport for all leads, tamping, watering, flooding, dressing etc. Any brick work required for ponding shall be paid separately under relevant item.

12.0 DAMP PROOF COURSE - (DPC)

12.1 All materials used for Damp Proof Course shall comply with EIL Specification No. 6-68-0002.

12.2 The 40 mm thick Damp Proof Course shall consist of plain cement concrete of minimum grade M20 (Nominal mix) with 10mm down aggregates.

12.3 Integral water proofing compound of approved make, conforming to IS:2645, shall be mixed with concrete as per manufacturer's specification.

12.4 The Damp Proof Course shall be laid at plinth level of masonry walls, flush with the floor surface and shall not be carried across doorways.

12.5 Before laying, the top surface of wall shall be thoroughly cleaned and watered. The DPC layer of 40mm thick shall be laid, retaining the edges vertical by necessary formwork and shall be well tamped and troweled to smooth finish. The layer shall be cured by keeping the surface wet for 40 hours and after it has dried, two coats of hot bitumen of grade VG10 conforming to IS:73 shall be applied over it at the rate of 1.7 kg/sqm for each coat. Over the layer of hot bitumen, dry sharp sand shall be sprinkled evenly before hardening of top coat of bitumen paint.

12.6 Payment

This clause shall apply to Item Rate tender only.

Payment shall be made on square metre (sq.m.) basis of the area laid with plain cement concrete. The rate shall be inclusive of formwork, providing and mixing Integral water proofing compound, curing, providing and laying bitumen, supplying and spreading sand over bitumen etc. all complete.

मानक विनिर्देशन
सिविल एवं संरचनात्मक कार्य

STANDARD SPECIFICATION
CIVIL AND STRUCTURAL WORKS

प्रीकास्ट कंक्रीट
PRECAST CONCRETE

Rev. No	Date	Purpose	Prepared by	Checked by	Standards Committee Convenor	Standards Bureau Chairman
2	17.05.2024	REVISED & REISSUED AS STANDARD SPECIFICATION	DB	RM	AS	MN
1	10.03.2019	REAFFIRMED & ISSUED AS STANDARD SPECIFICATION	AVM	AJS	RS	RKT
0	26.07.2013	ISSUED AS STANDARD SPECIFICATION	AK	VG/RS	PKM	DM

Approved by



Abbreviations:

IS: Indian Standard

Structural Standards Committee

Convenor: Mr. Anurag Sinha

Members: Mr. Virender Goel
Mr. Deepak Agrawal
Mr. VK Panwar
Mr. Amitabh Kishore
Mr. Gyasuddin
Mr. Charanjit Singh (Proj.)
Mr. Ravindra Kumar (Const.)

CONTENTS

1.0	GENERAL.....	4
2.0	QUALITY REQUIREMENTS.....	4
3.0	MANUFACTURE.....	4
4.0	CURING.....	5
5.0	MARKING.....	5
6.0	LIFTING, HANDLING, STORAGE & ERECTION.....	5
7.0	TRANSPORTATION.....	6
8.0	PAYMENT.....	6
9.0	ANNEXURE-I.....	7

1.0 GENERAL

This Specification defines the requirements for the manufacture of precast concrete units. Precast concrete units shall be designed and fabricated by an experienced and acceptable precast concrete manufacturer. The manufacturer shall have been regularly and continuously engaged in the manufacture of precast concrete units either RCC or PCC similar to that indicated in the project specifications or drawings for at least 7 years. The units to be precast shall take care of any special requirements specified in the "Contract Specific Requirements" or on the Drawings.

The precast units shall be manufactured in accordance with Specification No. 6-68-0004.

1.1 Reference Codes and Specifications

Apart from this specification, the construction of Precast concrete works shall be in accordance with the Indian Standard Code of Practice for "Building Design & Erection using Prefabricated Concrete" IS 15916 along with all amendments till date and other relevant codes mentioned therein.

2.0 QUALITY REQUIREMENTS

At a minimum, the Contractor's Quality Plan shall include the following documents, procedures and/or instructions:

- (a) Lifting methods (where not shown on the Drawings).
- (b) Erection methods including the erection sequence (where not shown on the Drawings).
- (c) Minimum concrete strength requirements prior to lifting (where not shown on the Drawings).
- (d) Where it is proposed to stack units, evidence to demonstrate the strength and stability of the stack.
- (e) Procedure/format of records keeping for precast works. (Refer Annexure -I).

This documentation shall be submitted at least 28 days prior to the commencement of site work, if not submitted beforehand.

3.0 MANUFACTURE

Formwork shall be of rigid construction and concrete vibration shall be such that intense concrete compaction will be achieved. This may require the use of form vibrators or vibrating tables on some large and/or complex-shaped units.

Formwork and embedded items shall not restrain movements nor damage precast units within the formwork due to the effects of shrinkage or steam curing.

The casting of the precast units shall be carried out on specially prepared casting beds which will prevent any distortion or misalignment of the forms during and after concreting. Each precast unit shall be cast in one continuous operation with no construction joints.

If the batch volume is less than 2 cubic metres, the sampling rate shall be reduced as follows:

- (a) Less than 2 cubic metres per batch : 50% rounded up

- (b) Less than 0.5 cubic metres per batch : 30% rounded up.

In any case a minimum of 1 test representing each member shall be undertaken. Test specimens, for the purpose of determination of adequate unit strength for lifting and handling, shall be subjected to the same curing regime as the unit they represent. The Contractor shall ensure that sufficient cubes are provided to enable the required testing to be undertaken.

4.0 CURING

Concrete shall be:

- (a) moist cured in accordance with Specification No. 6-68-0004 or
(b) membrane cured in accordance with Specification No. 6-68-0004

5.0 MARKING

For the purposes of unit curing, testing, location and orientation within the final structure, each batch of units, or if continuous production methods are used, each day's production, shall be clearly identified and indelibly marked to show:

- (a) Unit identification
(b) Date of manufacture.
(c) Marking of top and bottom surface to ensure correctness of the reinforcement.

Each unit shall be marked on a surface which is not visible in the final structure.

6.0 LIFTING, HANDLING, STORAGE AND ERECTION

Precast units shall not be lifted or handled before the concrete has attained a compressive strength of 10 MPa or strength required during lifting as per design requirement or as specified on the Drawings, whichever is greater.

The Contractor shall detail in the Quality Plan the measures to be taken to minimise handling stresses, in particular those due to de-moulding.

The Contractor shall carefully handle precast units by methods that will not damage them or their connections. Units shall be handled from the approved lifting points shown on the Drawings. Beams and slabs shall be lifted and supported with the top surfaces uppermost at all times, unless shown otherwise on the Drawings.

Units shall be stored clear of the ground and supported on non-staining timber bearers only at approved bearing points. The thickness and width of the bearers shall be compatible with the strength group of the timber used, the type of precast unit and the site. The bearers shall support the units over their full width at the specified lifting points. The ground or space between the bearers supporting the units shall be carefully cleared and leveled to prevent the unit from being supported at positions other than on the bearers. The bearers shall rest on a firm foundation and adequate precautions shall be taken to prevent subsidence.

If units are stacked in tiers, the bearers shall be placed directly over each other. The lowest unit shall not be overstressed.

Temporary props, if required, shall be used to hold the precast elements joints till it attain the required strength. After attaining the required strength, props shall be removed.

7.0 TRANSPORTATION

Unless stated otherwise on the Drawings, units shall not be transported until the concrete has reached its 28 day characteristic compressive strength and is at least 7 days old.

No unit shall be removed from the casting yard until a lot conformance package has been completed.

Submission of the lot conformance package prior to removal from the yard shall be required.

Units shall be securely fixed to the transporter by ties fitted with suitable tensioners. Provision shall be made to protect the units from damage caused by these ties.

Precast concrete units shall be delivered to the site in accordance with the delivery schedule to avoid excessive build-up of units in storage at the site. Upon delivery to the jobsite all precast concrete units shall be inspected by the Engineer-in-charge for quality and final acceptance.

8.0 PAYMENT

- 8.1 Payment for precast concrete members shall be made on cubic meter basis of the volume of the finished member. The rate quoted shall include cost of formwork, preparation of casting yard, finishing as specified, curing, marking, lifting, handling, storage, transportation to site of work, fixing in position etc. Reinforcement and pipe sleeves shall be paid separately under relevant items. Lifting hooks shall be paid on the same basis as reinforcement. Metal inserts shall be paid as per relevant clauses of Specification No. 6-68-0008 (Miscellaneous Steel Works).
- 8.2 The quoted rate shall be inclusive of providing pockets, openings, recesses of all sizes, chamfers, fillets grooves, holes, curing (hot, cold or by using curing compounds). The rate shall be deemed to include complete cost of taking and testing concrete cubes and carrying out other tests including tests of various ingredients as per specification and as directed by the Engineer-in-Charge.

ANNEXURE-I

Procedure/format of record keeping for precast works shall at least include the following:

I. PRE-POURING INSPECTION REPORT:

This shall include mould cleaning & oiling, inspection of shutter joints, reinforcement & cover check, prestressed strands check, inspection of lifting hooks, inserts, embedments, etc.

II. CONCRETE TESTING REPORT:

This shall include the strength attained by concrete at various stages i.e. de-shuttering, lifting transportation, erection, loading, with other structural components, grouting, etc.

III. POST POURING INSPECTION REPORT (PREDELIVERY / DISPATCH)

This shall include inspection of the size of precast element, honeycomb, cracks, exposed reinforcement, finishing works, etc.

मानक विनिर्देशन
सिविल एवं संरचनात्मक कार्य

बाईपोलर कंक्रीट अंतर्वेशित
क्षारण अंतर्अधिमिश्रण

STANDARD SPECIFICATION
CIVIL & STRUCTURAL WORKS

BIPOLAR CONCRETE PENETRATING
CORROSION INHIBITING ADMIXTURE

Rev. No	Date	Purpose	Prepared by	Checked by	Standards Committee Convenor	Standards Bureau Chairman
2	21.07.2025	UPDATED AND ISSUED AS STANDARD SPECIFICATION	AV	RM/SP	AS	MN
1	18.06.2019	UPDATED AND REISSUED	TK	AJS	RS	RKT
0	26.04.2012	ISSUED AS STANDARD SPECIFICATION	AJS	PKM	SC	DM

Approved by

ABBREVIATIONS:

AASHTO	:	American Association of State Highway and Transportation Officials
ASTM	:	American Society for Testing & Materials
CPCIA	:	Concrete Penetrating Corrosion Inhibiting Admixture
IS	:	Indian Standard
JIS	:	Japanese Industrial Standard
OPC	:	Ordinary Portland Cement
PPC	:	Portland Pozzolana Cement
PSC	:	Portland Slag Cement
SRC	:	Sulphate Resistant Cement

Structural Standards Committee:

Convener: Mr. Anurag Sinha

Members: Mr. Virender Goel
Mr. Deepak Agrawal
Ms Alpana Srivastava
Dr. Sudip Paul
Mr. Prasenjit Saha (SMMS)
Mr. Charanjit Singh (Project)
Mr. Indrajit Neog (Construction)
Ms Papia Mandal
Mr. Vikram Kumar Gupta

CONTENTS

1.0	SCOPE.....	4
2.0	REFERENCES	4
3.0	SAMPLING	4
4.0	TESTING REQUIREMENTS	4
5.0	HEALTH, SAFETY & ENVIRONMENT CONSIDERATIONS.....	5
6.0	PACKAGING.....	5
	ANNEXURE-A (SHORT TERM TESTS)	6
	ANNEXURE-B (LONG TERM TESTS)	7
	APPENDIX-I (MODIFIED ACCELERATED CORROSION TEST)	9
	APPENDIX-II (OPEN CIRCUIT POTENTIAL E_{corr} TEST)	10
	APPENDIX-III (REDUCTION IN CORROSION CURRENT I_{corr} TEST).....	12
	APPENDIX-IV (IMMERSION TEST).....	15
	APPENDIX-V (TEST FOR EFFECT ON COMPRESSIVE STRENGTH WITH CPCIA)....	16
	APPENDIX-VI (ELECTROCHEMICAL POLARIZATION TEST)	17
	APPENDIX-VII (CORROSION TEST)	18
	APPENDIX-VIII (CHLORIDE ION PENETRATION TEST)	19

1.0 SCOPE

This specification prescribes the requirements and test methods including performance test for evaluating the efficiency of Bipolar Concrete Penetrating Corrosion Inhibiting Admixture (CPCIA) for protecting steel reinforcement embedded in concrete from corrosion. Non-concrete penetrating, Nitrite & Nitrate corrosion inhibitors are excluded from the scope.

2.0 REFERENCES

2.1 Codes

ASTM G1-03, ASTM G3-14, ASTM G109, ASTM G180-04, ASTM C1202, JIS Z-1535, AASHTO T259, IS 2, IS 101(Part1/Sec.5), IS 456, IS 1202, IS 1448, IS 1786, IS 9103, etc.

2.2 EIL Specifications

6-68-0001 : General Scope
6-68-0002 : Materials

3.0 SAMPLING

3.1 The representative samples of the material shall be drawn as per the table given below:

No. of containers (Lot)	No. of containers to be selected for sampling (N)
Up to 50	1
51-100	2
101-300	3
301-500	4
501& Above	5 Plus 1 for every lot of 300 containers

4.0 TESTING REQUIREMENTS

4.1 The product shall comply with the requirements specified in Annexure-A (Short Term Tests) and Annexure-B (Long Term Tests). Both the tests shall be conducted in an approved laboratory.

4.2 Unless specified otherwise, all the tests under Indian tropical conditions shall be conducted at room temperature $27 \pm 2^\circ\text{C}$ and relative humidity at $65 \pm 5\%$ in a well ventilated chamber free from dust.

4.3 The contractor shall select the product from EIL approved vendor list and submit the Manufacturer Test Certificate to the Engineer-in-Charge. Approval for usage of product shall be given after satisfactory Short Term test results. Long Term tests are not mandatory for the products listed in EIL approved vendor list.

If the product is not from an EIL approved vendor, both Short term as well as Long term tests are mandatory. The contractor shall submit the Manufacturer Test Certificate to the Engineer-in-Charge and approval for usage of product shall be given after satisfactory Short Term test results. However, payment shall be released after the product complies with the requirements of Long Term test results.

5.0 HEALTH, SAFETY & ENVIRONMENT CONSIDERATIONS

- 5.1 The CPCIA shall not cause harm to applicators by mean of inhalation or skin contact. All precautionary measures shall be prescribed by the manufacturers along with instructions of usage. Application methodology shall be approved by the Engineer-in-Charge.
- 5.2 The waste shall be discharged in accordance with applicable Environmental laws of land.
- 5.3 CPCIA shall not degrade or damage the construction materials like concrete, aggregates, steel reinforcement, formwork/shuttering.

6.0 PACKAGING

The product shall be supplied in air tight containers and following information shall be labeled on each container:

- a) Name of the material
- b) Name of the manufacturer
- c) Volume/ weight of material
- d) Specification number
- e) Batch No. or Lot No. in bar code or otherwise
- f) Month and year of manufacture
- g) Ingredients & method of usage
- h) Instructions for safe usage

ANNEXURE-A

SHORT TERM TESTS

S. No.	Characteristics	Requirements	Methods of Tests
1.	Appearance	Brownish Liquid free from any visible residual deposits	Visually
2.	Odour	Mild Ammonical Odour	By smell
3.	Skin irritation	No irritation	By applying on reverse of the palm for 5 minutes.
4.	Ph i) As in supplied condition ii) 1% dilution ,w/w	i) 9.0-12.0 ii) 9.0-12.0	pH meter / Standard pH paper
5.	Specific Gravity at 27 ± 2°C	1- 1.1	IS 1448
6.	Viscosity of the material as in supplied condition, by Ford cup No 4, at 27 ± 2°C	10 - 20 sec.	IS 101(Pt.1/Sec.5)
7.	Accelerated Corrosion Test, for 21 hrs. i) Raw water without CPCIA ii) Raw water with CPCIA	i) Excessive corrosion spots. ii) There shall not be more than 1-2 corrosion spots.	Modified accelerated corrosion test based on Japanese standard JIS Z 1535 (Refer Appendix-I)
8.	Open circuit potential E _{Corr} Test	Minimum shift in potential by 120 mV upon addition of CPCIA	Modified ASTM G 69 (Refer Appendix-II)
9.	Reduction in Corrosion Current I _{Corr}	Minimum reduction by 15 times upon addition of CPCIA	Modified ASTM G 69 (Refer Appendix-III)
10.	Electrical resistivity (R)	R with CPCIA ≥ R without CPCIA	ASTM C1876

Notes:

- a) Tests of Sr. Nos. 7, 8, and 9 shall be performed from supplied material received at the site and witnessed by the owner's representative or Engineer in Charge.

ANNEXURE-B

LONG TERM TESTS
(Shall be performed in triplicate)

S. No .	Characteristics	Requirements		Methods of Tests
		Without CPCIA	With 1% CPCIA	
1.	Immersion test for 720 hrs. (Rebar weight loss method)	40.00 mpy, max.	2.00 mpy, max.	Immersion Test (Rebar weight loss test) as per ASTM G1-03 (Refer Appendix-IV)
2.	Effect of Concrete admixture on compressive strength	Concrete strength in sample with CPCIA* should be \geq concrete strength in sample without CPCIA*		Test for effect on compressive strength by addition of CPCIA as per IS 9103 (Refer Appendix-V)
3.	Polarization test by Tafel polarization with 3.5% Sodium Chloride, for 20 days: Rate of corrosion shall be	45 mpy, max.	9 mpy, max.	Electrochemical polarization test conducted on steel rebars embedded in concrete as per ASTM- G 3-14 & IS 9103 (Refer Appendix-VI)
4.	Effect of CPCIA* on corrosion of embedded steel rebars exposed to chloride environments after 09 cycles (14 days wetting and 14 days drying): Rate of corrosion shall be	25 Coulombs, max.	0.50 Coulombs, max.	Long term corrosion test as per ASTM G109 (Refer Appendix-VII)
5.	Chloride Migration profile properties of concrete (for all types of cements viz. OPC, PPC, PSC, SRC) i) Chloride % in concrete at 30mm depth after 90 days. ii) Ability to resist chloride ion penetration a) Concrete grade M-30, Water cement ratio: 0.45 b) Concrete grade M-40, Water cement ratio: 0.40	0.025%, max. 1650 Coulombs, max. 1550 Coulombs, max.	Nil 1000 Coulombs, max. 1000 Coulombs, max.	AASHTO T-259 (Refer Appendix-VIII) Chloride ion penetration (Salt ponding test) as per IS 456 Electrical indication of concrete ability to resist Chloride Ion Penetration (Rapid Chloride Permeability test) as per ASTM C1202

6.	Initial screening of CPCIA for Steel in Concrete	Meeting criteria as described in point number 8, "Interpretation of Results"	ASTM G180-04
----	--	--	--------------

Notes:

- a) CPCIA* : The CPCIA shall be used as 1% w/w of cement or as recommended by the manufacturer for conducting the tests mentioned in Annexure-B except Immersion test for 720 hrs. mentioned at S.No.1 where it shall be used as 1% w/w of water or as recommended by the manufacturer.
- b) Rebars conforming to IS 1786 shall be used for testing purposes

APPENDIX-I

MODIFIED ACCELERATED CORROSION TEST
(BASED ON JAPANESE STANDARD JIS Z 1535)

TEST PROCEDURE

Attach steel test pieces conforming to IS 1786 (of size approx. 15mm dia and 12mm thickness drilled from one side c/c to a dia of 10mm and a depth of 10 mm to hold the Aluminium pipe) after thorough cleaning to white metal by using 1000 grade grit paper and subsequently polishing with 3/0 grade and finally with 4/0 grade grit paper to the Aluminium pipe with the help of cello tape so that it is firmly attached. The Aluminium pipe is then slid upwards till the test piece rests in the slot provided in the rubber cork, as shown in the figure.

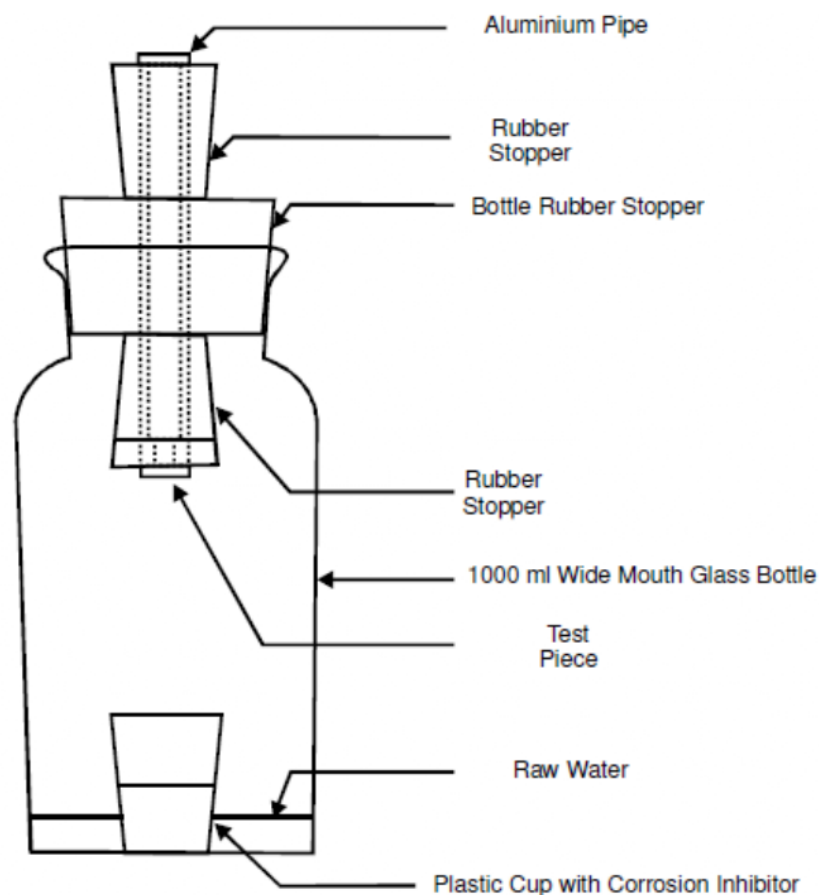

Assembly with Corrosion Inhibitor

Pour 100 ml of tap water in both the bottles. Fill the plastic cup with 25 ml CPCIA solution as in supplied condition. In one of the bottles place the plastic cup with the CPCIA solution so that the cup is placed in the tap water. Allow to remain for 18 hours at ambient temperature. After 18 hrs. add chilled water having temperature below 1.0 °C into the Aluminium pipes and allow to remain for 3 hrs. The temperature of the chilled water in the Aluminium pipes shall be maintained at 2.0 ± 0.5 °C by frequently changing the chilled water with the help of the pipette. Observe the steel test pieces after the experiments i.e. 18+3=21 hrs., for any corrosion spots.

APPENDIX-II

OPEN CIRCUIT POTENTIAL (E_{corr}) TEST

This test is intended to show a live demonstration of the reduction in corrosion potential of steel under 3.5 % NaCl water with the addition of corrosion inhibitor.

Test Apparatus & Consumables

- **Working Electrode** : Polished TMT steel sample (dia. 15 ± 2 mm) embedded in cast epoxy/polymer
- **Reference Electrode** : Saturated Calomel Electrode (SCE) with KCl inserted
- **Voltmeter** : High Input resistance Digital Multimeter
- **Electrolyte Medium** : 3.5 % NaCl water solution 250 ml (Temperature 25-28°C).
- **Water** : DM water or Potable water (Maximum TDS 200)
- **Salt** : Sodium chloride (lab grade) or table salt white powder
- **Test Temperature** : Ambient /At room temperature 23 to 35°C

Sample Preparation

(a) Working Electrode : A working electrode shall be prepared by selecting proper available size of TMT/Carbon steel rebar, a desirable diameter is 16 mm or 20 mm, steel cutting & turning longitudinally on lathe machine to achieve desired shape & size as given in Fig.1. After that, a strong joint connection should be made by soldering or brazing a flexible, shielded and approximately 1 feet long copper wire to the steel disk over the round flat surface to achieve good electrical continuity. For masking this steel & joint connection, use a strong two-pack adhesive (polymer or epoxy system). Choose a proper size of mould and cast this probe attached steel by keeping it in the center of polymer as shown in Fig. 1. The sealed electrode should not leak from any side. Before proceeding to open circuit potential (OCP) testing, a good electrical continuity must be ensured between the exposed steel surface and the copper wire end by checking through a continuity tester or multimeter.

(b) Surface Polishing Preparation: The exposed surface of the mounted sample, the working electrode, should be polished very neatly and systematically up to the mirror finish level without any scratch marks. Follow the stepwise procedure for the preparation:

1. For polishing, keep emery paper horizontal on a clean & plain surface and start polishing with a coarser grade of emery paper 200 grit, or if necessary, start with 100 grit & use subsequent finer grades, i.e., 200, 300, 400, 600, 800/1000, or 1200, & finally 02/04 grade.
2. Hold the sample tightly by hand & rub it on the exposed surface in full strokes in the forward direction and raise hand backward without rubbing on paper, similarly repeat the process until the complete grinding of the surface comes evenly in one direction.
3. To shift further to a finer grade turn the sample in perpendicular position (90 degrees) rather than previous direction & polish back and forth as in previous cycle. Continue this for subsequently every new paper and in addition to this before starting a new paper grade simultaneously wipe off surface with clean cloth or tissue paper using acetone / methanol solvent to remove any previous dirt picked up by the sample. Repeat the stepwise procedure systematically until a final mirror finish level is achieved without any scratch line mark.

Testing Procedure

1. Take a clean glass beaker of 500 ml capacity.
2. Fill the beaker with 3.5 % NaCl electrolyte water solution up to 250 ml.

3. Prepare a working electrode of 15 ± 2 mm dia. disk by cutting & grinding longitudinally TMT reinforced steel as per IS 1786 & solder it with a copper wire to edge of round section. It is completely bounded with epoxy/polymer casting, except the facing portion in exposed conditions. (refer Fig. 1a)
4. The exposed surface of steel must be hand polished with graded emery paper as explained in sample preparation.
5. Clean the polished surface with alcohol or any organic solvent & put the working electrode in the beaker containing the electrolyte solution.
6. For measuring E_{corr} of the polished steel surface in electrolyte solution, connect the other end (probe) of the copper wire to positive polarity of multimeter & turn the knob to the DC volt 2-5 mV range. Similarly connect the SCE banana pin to the -ve terminal of multimeter, after that immerse the SCE electrode near to exposed steel in the electrolyte solution up to the center of the exposed steel area (Refer figure 2), and ensure minimum gap between two electrodes.
7. Measure the reading. It must be more negative than -500 mV, or wait till it reaches between -500 to -550 mV (idle condition is > -550 mV w.r.t. SCE).
8. After showing $E_{corr} > -500$ mV by multimeter, now add 2% of corrosion inhibitor by volume of the total electrolyte solution. Stir the solution slowly & wait up to 15-20 minutes.
9. The E_{corr} of steel will shift towards the positive side as compared to the initial E_{corr} without the addition of corrosion inhibitor (a minimum shift of -120 mV in E_{corr} value is preferable for this test).

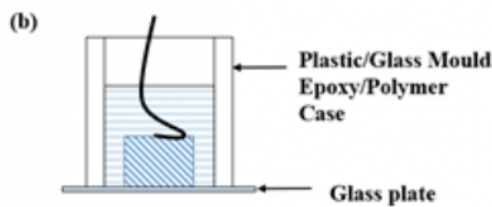
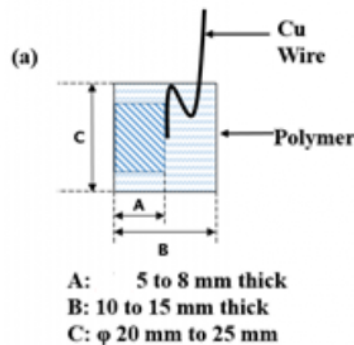

Figure 1.

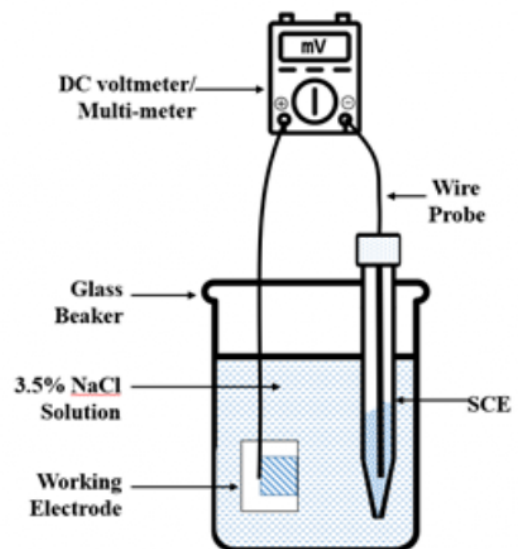

Figure 2.

Result Interpretation

Shifting of E_{corr} towards the positive side by min. 120 mV clearly indicates that the corrosion inhibitor is capable of inhibiting corrosion, which displaces the corrosive ion away & chemically generates an invisible passive film on the steel surface when the corrosion inhibitor is added to the electrolyte solution.

APPENDIX-III

INSTANT REDUCTION IN CORROSION CURRENT (I_{Corr}) AT FREE CORROSION POTENTIAL (E_{Corr}) ON SURFACE TREATED REINFORCED TMT/CARBON STEEL WITH CORROSION INHIBITOR

This test is intended to show a live demonstration of reduction in ongoing instant corrosion current when the surface attains near corrosion cell potential (E_{Corr}), which is measured by SCE reference electrode of TMT/Carbon Steel under 3.5 % NaCl water solution with the addition of corrosion inhibitor. This is a short term electrochemical test which can be carried out easily in the laboratory to measure the quality and performance evaluation of corrosion inhibitor directly against TMT/Carbon steel rebar for the corrosion protection of steel in the concrete in a very short duration at ambient temperature.

Test Apparatus & Consumables

- **Working Electrode** : Surface finished TMT or Carbon steel rod sample (dia .10 mm to 16mm) treated with shot blasting or acid pickling (bright or silver finishing level)
- **Reference Electrode** : Saturated Calomel Electrode (SCE) with KCl inserted
- **Voltmeter** : High input resistance digital multimeter
- **Ammeter** : Very low resistance ammeter/ multimeter in DC micro and milliamperere range
- **Counter Electrode** : Noble series metal (Nichrome/ Titanium/ SS 316 grade mesh)
- **Electrolyte Medium** : 3.5 % NaCl water solution 200 ml. (Temp. 25-28^oC).
- **Electrode support holder** : Non metallic or plastic disc having three hole around the disc
- **Water** : Clean potable water max. TDS 200
- **Salt** : Sodium chloride (lab grade) or table salt (white powder)
- **Test Temperature** : Ambient to 35 ^oC

Working electrode preparation

A surface treatment process like blasting or pickling should be carried out over the tempered martensite zone on the top of outer core surface of TMT rebar and it should be done completely free from rust & pit without any crevice marks or corrosion spots.

Since different surface treatment processes attributes significant variation in the corrosion potential and corrosion current of steel due to the intense degree of reaction taking place on the surface topography & profile across varying surface roughness as well as the rapid formation of active anodic and active cathodic cells on the metal surface when exposed to an electrolytic solution at a particular temperature, therefore the comparison shall be made between similar kinds of surface preparation treatments i.e. acid pickling, shot blasting, mechanical polishing or any other types in view to compare the inter and intra laboratory test results.

Counter electrode (CE): A counter electrode mesh made from a metal more noble than carbon steel must be used. The surface area of the CE should be at least 5 times or greater than that of the working electrode.

Testing Procedure

1. Take a clean glass beaker of 500 ml capacity.
2. Fill the beaker with 3.5 % NaCl electrolyte solution up to 350 ml.
3. Prepare the working electrode by selecting a suitable dia. of 12 mm TMT/reinforced steel up to 200 mm in length. The surface finish shall be prepared with fine shot blasting grit or acid pickling, & rinse with plenty of water prior to washing with alkaline solution.

4. The treated surface area of steel, i.e. the area under test in the electrolyte must be cleaned thoroughly with an organic solvent (acetone/methanol or alcohol) before placing it in the chloride solution.
5. Place the cylindrical-shaped mesh as the counter electrode (SS 316 or superior metal mesh) inside the glass beaker by covering circumferential touching the beaker & shall be over around the test steel working electrode. For measuring corrosion current, extend a sufficient portion of the mesh outside the beaker for making contact with the ammeter probe.
6. Now insert the TMT steel working electrode in the centre of the beaker through a suitable nonmetallic support cover & again insert the calomel ref. electrode in between mesh & working electrode location through the nonmetallic support 12.5 mm hole.
7. First for measuring E_{corr} by using voltmeter connect the (+) polarity probe at top side of TMT steel rebar & connect banana socket pin adjoining calomel electrode to the (-) terminal of socket on voltmeter range and switch on the voltmeter by keeping the knob on the 2 or 5 DC mV range. Measure the reading, it must be more negative than -550 mV or wait till it reaches in between -550 to -625 mV (idle condition is around -600 mV w.r.t. SCE).
8. In the meantime, make connection ready for connecting DC ammeter probe, connect one terminal of the probe to the counter mesh electrode, and connect other end to the DC current socket on the ammeter through a toggle switch by keeping DC current on more than 10 mA range, the second end of probe shall be maintained in standby mode to connect directly to the working electrode when it is required. Keep watching the voltmeter reading, when it is showing around -600 mV (± 10 mV), then note down the reading & immediately disconnect the TMT steel connection through the toggle switch connected with voltmeter & connect the ammeter probe to the TMT steel electrode promptly. Read out the current reading in mA range carefully and continuously. Note down the reading after 3 seconds time has elapsed right from the time of immediate connecting probe to the steel electrode. So, this current & voltage reading of TMT steel shall be considered the maximum value in 3.5 % chloride solution before the addition of the inhibitor.
9. Now add 3 % of bipolar corrosion inhibitor to the electrolyte solution & stir properly with a portable stirrer or spatula to mix the solution homogeneously. Disconnect the working electrode probe from the ammeter & connect it with the voltmeter probe. Continuously watch the E_{corr} reading, leave it in this position for 15 to 20 minutes. Finally, the E_{corr} reading will gradually decrease until maximum reduction is observed towards the positive side. At the moment when it reaches momentarily in stable condition and comes down to maximum 120 mV or more reduction in mV value versus previous E_{corr} reading then note down the final E_{corr} reading & disconnect the steel probe & immediately connect the ammeter probe to the steel electrode. Note down the current readings in microampere range after 3 seconds of visible reading at just moment of connecting probes as mentioned in point no. 8.

To avoid jumbled wire connections & simplify the operation during testing a user can conduct this test in a more comfortable and simple way by using a SPDT switch board with a multiple probe connection setup.

Result Interpretation

The E_{corr} of steel will shift towards positive side as compared to initial E_{corr} without addition of corrosion inhibitor. The current (I_{corr}) will also reduce instantly, and the preferable value of reduction in current is minimum 15 times lower than the value without addition of corrosion inhibitor in the chloride solution.

Remark

Shifting of E_{corr} towards the positive side along with ongoing current which is falling rapidly, clearly indicates that the corrosion inhibitor is capable of inhibiting corrosion by displacing the corrosive ions away & chemically generating an invisible passive film on the steel surface when added to the electrolyte solution.

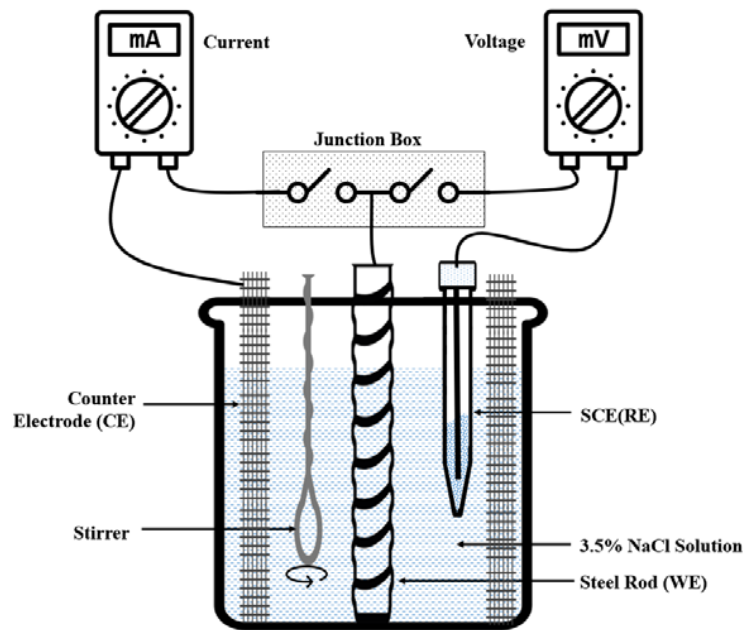

Pictures showing different surface treated TMT Steel reinforced bar

The results should include the following:

1. Type and size of rebar (diameter and length).
2. Types of surface treatment processes on steel in detail.
3. Max. E_{corr} & I_{corr} values just before the addition of the corrosion inhibitor.
4. Added dosage of corrosion inhibitor to the electrolytes.
5. Final values of reduced E_{corr} & I_{corr} measured after adding the bipolar corrosion inhibitor.
6. Lag time duration in seconds (waiting period in seconds) when taking corrosion current readings after switching on the ammeter.
7. Temperature of the electrolytic solution & the surrounding room temperature.

APPENDIX-IV

IMMERSION TEST (REBAR WEIGHT LOSS TEST)
(AS PER ASTM G 1)

TEST PROCEDURE

Take six pieces of Tor steel rebar conforming to IS 1786 of size approx. 40 mm length and 10 mm dia. Clean the rebar of any rust, mill scale etc., with the help of steel wire brush, till it has overall a shining surface. Now clean all the six pieces with solvent such as Benzene/Acetone to remove any loose rust /dust from the surface. Dry at 100 ± 2 °C for 15 minutes in an oven. Cool and take the weights of all the six pieces and record it.

Take six transparent glass/plastic bottles of approx. 150±10 ml with air tight caps. Clean all the bottles with tap water and then fill them with 100 ml of tap water so that the bottles are approx. three fourth filled. In three of the six bottles, add CPCIA 1%, w/w or as recommended by the manufacturer of the water in the bottle. Now put one cleaned and weighed rebar test piece completely immersed in water/water + CPCIA, in all the six bottles and close the cap.

After 30 days (720 hrs.), take out all the six test pieces and put them in Clark solution (prepared by dissolving 20 gms. of Antimony Trioxide and 50 gms of Stannous Chloride in 1000 ml of Conc. Hydrochloric acid, S.G. 1.18) so that corrosion products are dissolved. After complete removal of corrosion products (in 5 minutes approximate), take out the test pieces and wash in running water and finally with distilled water. Then wash the test pieces, with solvent such as Benzene/Acetone. Dry at 100 ± 2 °C for 30 minutes in an oven. Cool and take the weights of all the six pieces and record it.

Calculate the corrosion rate in mpy, by using the formula

$$\text{Corrosion rate (mpy)} = 534 (W1-W2) / DAT$$

Where W1-W2 is the weight loss in mg., D is the density of steel , A is the area in sq.inch and T is the time of exposure in hrs

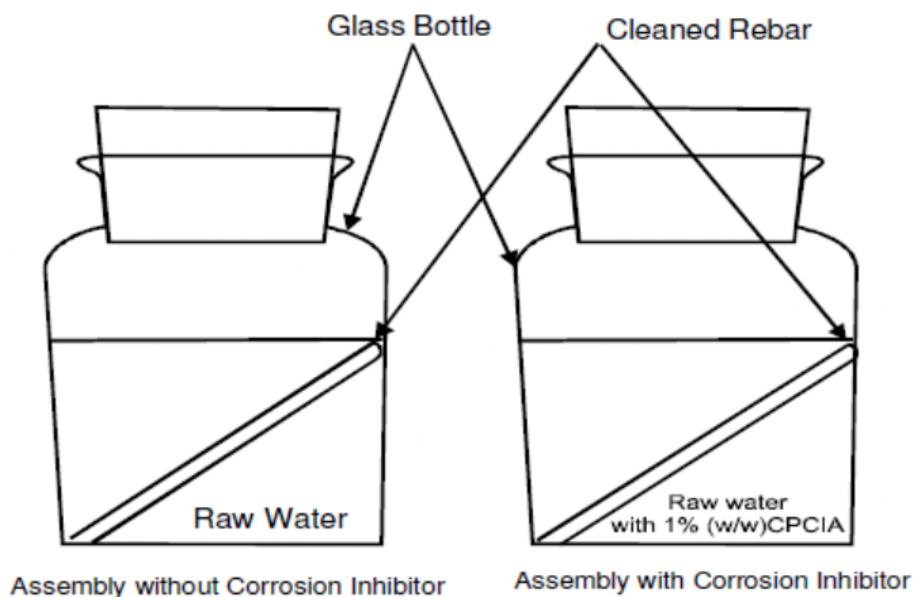

APPENDIX-V

TEST FOR EFFECT ON COMPRESSIVE STRENGTH BY ADDITION OF CPCIA

TEST PROCEDURE

Cast three concrete blocks of size 100mm x 100mm x 100mm each without and with CPCIA 1% (w/w) of cement or as recommended by the manufacturer, by casting the concrete of M20 grade as per Clause 6.2.3 of IS 9103.

The above casted blocks shall be demoulded after 24 hrs. These blocks shall be moist cured for 28 days. After completion of the curing period, the blocks of each type shall be tested for compressive strength in compression testing machine (Universal Tensile Machine) and data recorded.

APPENDIX-VI

**BRIEF OUTLINES OF ELECTROCHEMICAL POLARIZATION TEST CONDUCTED ON
STEEL REBARS EMBEDDED IN CONCRETE (AS PER ASTM G 3)**

TEST PROCEDURE

Cast three concrete cylinders, of size 75mm dia and 150mm length each without and with CPCIA 1% (w/w) of cement or as recommended by the manufacturer, by casting the concrete of M 20 grade as per Clause 6.2.3 of IS 9103, and placement of one cleaned rebar conforming to IS1786 of size 375mm length and 12mm dia (preferably cleaned by pickling in Hydrochloric acid 20% (v/v) approximately, till surface shines and washed in running water) in each block .

The above casted blocks shall be demoulded after 24 hrs. These blocks shall be moist cured for 28 days.

After completion of the curing period, the blocks shall be subjected for Polarization test for 20 days as per ASTM G-3 and observations recorded.

APPENDIX-VII

BRIEF OUTLINES OF LONG TERM CORROSION TEST
(AS PER ASTM G 109)

TEST PROCEDURE

Three specimens each of control concrete and that of CPCIA admixed concrete (1% w/w of cement or as recommended by the manufacturer) should be cast as per the size 280mmx150mmx115mm and with placement of three cleaned reinforcement bars conforming to IS 1786 (preferably cleaned by picking in Hydrochloric acid 20% (v/v) approx, till surface shines and washed in running water) of size 12mm and length 375mm as per the details shown in the figure. Admixture shall be added as per manufacturers recommended dosage. All the casted concrete samples shall be moist cured for 28 days.

Ponding of samples with 3% NaCl solution as shown in the figure to be continued and measuring of voltage across 100-ohm resistor to be continued beginning of the second week of ponding. Calculate the current IJ from the measured voltage and record. Also measure the corrosion potential of the bars against reference electrode. The experiment should be continued till the macrocell current reaches a value of 10 μ A. After the experiment break the specimens and examine the rebars for extent of corrosion, measure the corroded area and record.

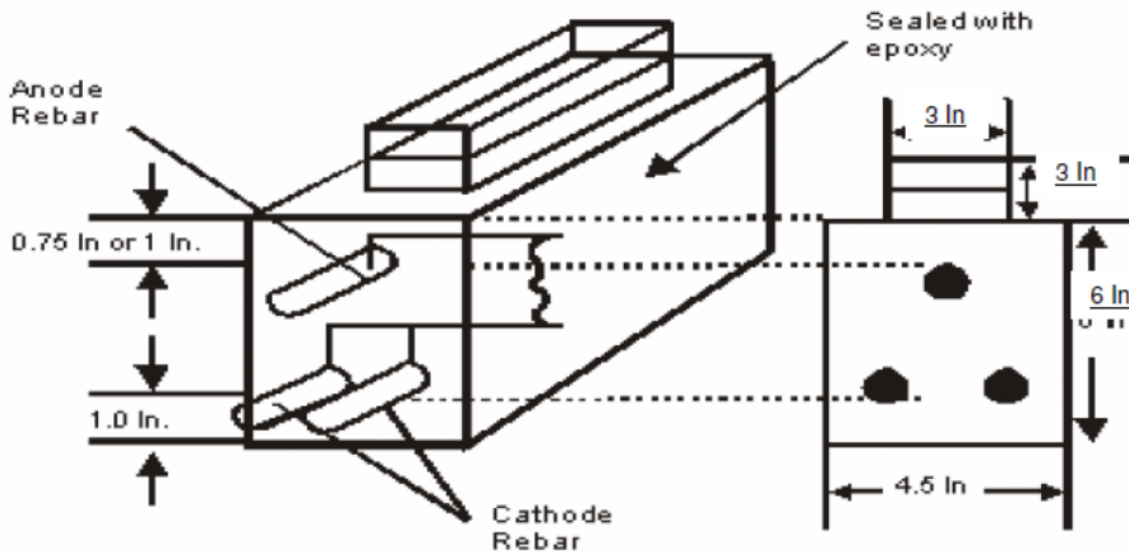

Note - All Measurements in In. (25.4 mm = 1 In.)

APPENDIX-VIII

BRIEF OUTLINES OF RESISTANCE OF CONCRETE TO MIGRATION OF
CHLORIDE ION TEST (AS PER AASHTO T259)

Part-A : Chloride Ion Penetration (Salt Ponding Test As per IS 456)

TEST PROCEDURE

Cast three concrete blocks of size 300mmx300mmx75mm each without and with CPCIA 1% (w/w) or as recommended by the manufacturer, by using the concrete mix as under:

S.No.	Material	M30 (Kg)	M40 (Kg)
i)	53 Grade Cement	50	50
ii)	Coarse Sand	104	87
iii)	Aggregate, passes through 20 mm and retained on 10 mesh	160	134
iv)	Water (subject to 55±5 slump)	24	20
v)	CPCIA	0.5*	0.5*
* as recommended by the manufacturer with each type of cement viz. Ordinary Portland Cement, Portland Pozzolana Cement, Portland Slag cement, Sulphate resisting Cement			

AASHTO T259 test (commonly referred to as the salt ponding test) is a long-term test for measuring the penetration of Chloride ions into concrete. Three slabs of 75 mm thick and having a surface area of 300 mm square shall be casted. These slabs are moist cured for 14 days and then stored in drying room at 50 percent relative humidity for 28 days. The sides of the slabs are sealed except for bottom and top face. After the conditioning period, a 3% NaCl solution is ponded on the top surface for 90 days, while the bottom face is left exposed to the drying environment (see figure below).

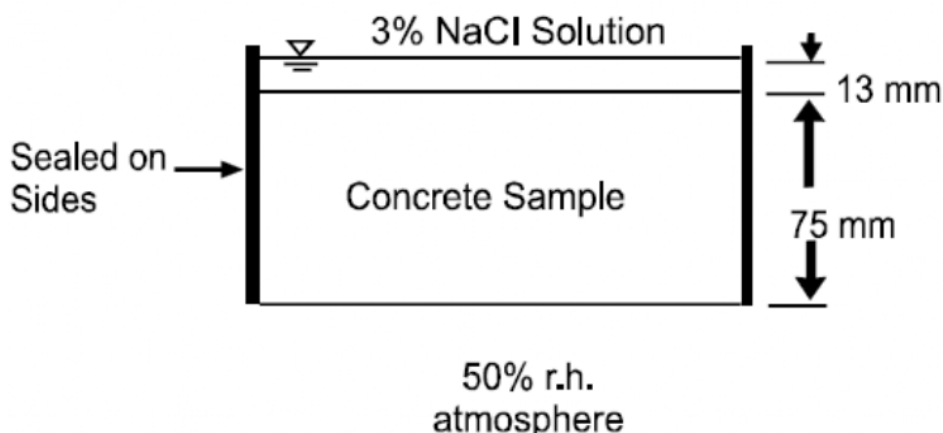

Figure: AASHTO T259 (Salt ponding) test setup

At the end of this time (90 days) the slabs are removed from the drying environment and the Chloride concentration of 10 mm thick slices is then determined (AASHTO T259). Two or three slices are taken at progressive depth. The salt ponding test does provide a crude one-dimensional chloride ion ingress profile. Test results should meet the requirements as stipulated in IS 456.

BRIEF OUTLINES OF RESISTANCE OF CONCRETE TO MIGRATION OF CHLORIDE ION TEST (AS PER AASHTO T259).....Contd.

**Part-B : Electrical Indication of Concrete's Ability to Resist Chloride Ion Penetration
(Rapid Chloride Permeability test As per ASTM C-1202)**

TEST PROCEDURE

Cast three concrete cylinders of size 50 mm thick, 100 mm diameter without and with CPCIA 1% (w/w) or as recommended by the manufacturer, by using the concrete mix as under:

S.No.	Material	M 30 (Kg)	M 40 (Kg)
i)	53 Grade Cement	50	50
ii)	Coarse Sand	104	87
iii)	Aggregate, passes through 20 mm and retained on 10 mesh	160	134
iv)	Water (subject to 55±5 slump)	24	20
v)	CPCIA	0.5*	0.5*
* as recommended by the manufacturer with each type of cement viz. Ordinary Portland Cement, Portland Pozzolana Cement, Portland Slag cement, Sulphate resisting Cement			

As per ASTM C-1202, water-saturated concrete specimen is subjected to a 60 V applied DC voltage for 6 hrs. using the apparatus shown in Figure below. In one reservoir is a 3.0% NaCl solution and in the other reservoir is a 0.3 M NaOH solution. The total charge passed is determined and this is used to rate the concrete's resistance to chloride ion penetration.

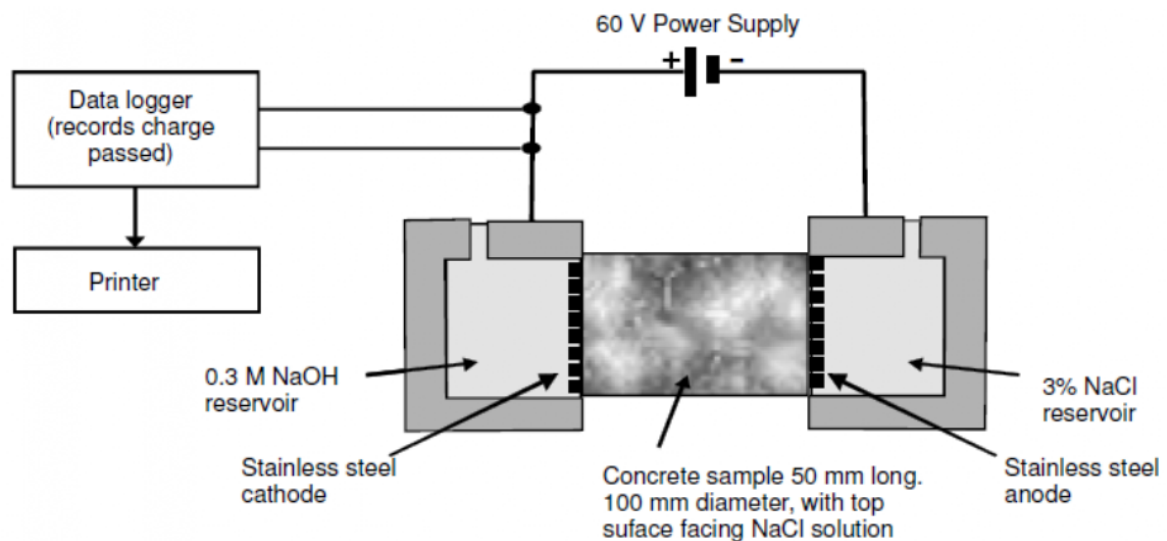

Figure: AASHTO T277 (ASTM C1202) test setup

मानक विनिर्देशन
सिविल एवं संरचनात्मक कार्य

STANDARD SPECIFICATION
CIVIL & STRUCTURAL WORKS

इपोकसी रेजिन प्रणाली द्वारा नई कंक्रीट को
पुरानी कंक्रीट से जोड़ना

BONDING FRESH CONCRETE TO
OLD CONCRETE BY EPOXY RESIN
BONDING SYSTEM

5	28.02.25	REVISED & REISSUED	Riya RIFA	Vikram VIKRAM	AS	MN
4	28.01.20	REAFFIRMED & REISSUED	IQBAL	ALPANA	RS	RKT
3	21.08.14	REAFFIRMED & REISSUED	AJS	AS	PKM	SC
2	30.06.09	REAFFIRMED & REISSUED	AS	SCH	VINAY KUMAR	N.DUARI
1	16.06.99	REISSUED AS STANDARD SPECIFICATION	RPM	RS	SCJ	A. SONI
Rev. No	Date	Purpose	Prepared by	Checked by	Standards Committee Convenor	Standards Bureau Chairman
						Approved by

Abbreviations:

ASTM : American Society for Testing & Materials

Structural Standards Committee

Convenor: Mr. Anurag Sinha

Members: Mr. Virender Goel
Mr. Deepak Agrawal
Ms. Alpana Srivastava
Dr. Sudip Paul
Mr. Charanjit Singh (Projects)
Mr. Indrajit Neog (Construction)
Ms. Papia Mandal
Mr. Vikram Kumar Gupta

CONTENTS

1.0	SCOPE.....	4
2.0	MATERIALS	4
3.0	SPECIAL REQUIREMENT	5
4.0	APPLICATION	5
5.0	APPROACH, WORKING PLATFORM & SCAFFOLDING.....	6
6.0	PAYMENT	6

1.0 SCOPE

- 1.1 This specification defines the material, constructional and other performance requirements for proper bonding of fresh concrete to old, hardened concrete by epoxy resin bonding system which is able to cure under humid conditions and bond to damp surfaces. Any special requirement as shown or noted on the drawings and directed by the Engineer-in-Charge shall govern over the provisions of this specification.
- 1.2 Actual working shall be carried out in accordance with this specification and recommendation of the manufacturer of the resin system to suit specific requirements for the particular site and other climatic conditions existing there. In case of any conflict, this specification shall govern.

2.0 MATERIALS

- 2.1 Epoxy resin system used for bonding fresh concrete to old hardened concrete shall consist of two components, viz. epoxy resin and hardener for combining immediately prior to use as per manufacturer's recommendations. Filler material shall be added, if required, as per manufacturer's specification. However, this shall be incorporated in any of the two components. The system shall cure under humid conditions and bond to damp surfaces.
- 2.2 The bonding material shall be compatible with the concrete to which it is to be applied and shall have the following minimum properties:

Compressive Yield Strength	55 N/mm ² (7 days)
Tensile Strength	40 N/mm ² (7 days)
Bond Strength	10 N/mm ² (14 days)
Flexure Strength	35 N/mm ² (7 days)
Shear Strength	10 N/mm ² (7 days)
Pot Life	45 minutes
Full Cure	7 days at 20°C to 35°C
Overlaying Time (open time)	1 hour at 20°C to 35°C

- 2.3 The resin and hardener shall be mixed in the proportion as specified by the manufacturer. The preparation, mixing and application of the resin system shall strictly be in accordance with the manufacturer's recommendations.
- 2.4 Certificate of test results of all the materials from BIS/NABL recognised laboratories duly authenticated by the approved manufacturer(s) shall be submitted to Engineer-in-Charge and got approved by him in writing prior to commencement of work. In the event of failure to submit such test results from the manufacturer for any material, the contractor shall carry the tests from an approved laboratory and submit the test results including the name(s) of manufacturer(s) to the Engineer-in-Charge and get approved by him in writing prior to commencement of work. All tests shall be in accordance with ASTM C881M (Type V) in case of non-availability of any specific Indian Standard.

2.5 Pot life and open time

Pot life is the period during which the resin system after mixing retains sufficient workability for proper use and the resin system must be applied to the prepared concrete surface within this period.

The 'open time' is the maximum period of time allowable between application of resin system and pouring of fresh concrete. Exceeding the 'open time' shall result in considerably reduced adhesion. The adhesive shall be applied to the prepared substrata as soon as the components have been mixed and fresh concrete shall be poured immediately before adhesive begins to gel. The bonding of fresh concrete to old concrete shall not to be done if the temperature is below 10°C.

3.0 SPECIAL REQUIREMENT

3.1 All works covered by this specification shall be carried out by experienced and approved agency having sufficient knowledge in epoxy resin treatment works. Only skilled and experienced operators shall be employed for the purpose.

4.0 APPLICATION

4.1 Preparation of Concrete Surface

4.1.1 Grease, oil, algae and other foreign substances likely to impair good bonding shall be thoroughly removed from the surface by scrubbing or using detergent and washing with clean water. All loose and spalling concrete pieces shall be removed. The surface to be bonded shall be made thoroughly rough by chiselling, taking off the skin of concrete and sharp edges of aggregate shall be exposed. The surface shall be washed, wetted cleaned and dried with dry compressed air. Exposed reinforcement shall be thoroughly cleaned with sand paper and wire brushes to remove all dust and sticking mortar.

4.2 Mixing

4.2.1 The resin and hardener shall be thoroughly mixed in a mixer. The approved resin system shall be prepared strictly as per manufacturer's recommendations. It shall not contain lumps and shall have uniform colour. Filler material shall be added if so specified by the manufacturer. Hand mixing shall be allowed for small quantity with prior permission of the Engineer-in-Charge.

4.3 Method of Application

4.3.1 The resin system shall be applied by spraying to the prepared surface. Manual application by using stiff nylon bristle brush may also be allowed with prior permission of the Engineer-in-Charge. The manufacturer shall specify the method of application suitable for the specified work.

4.4 Coverage

4.4.1 A minimum of half kilogram per square metre ($\frac{1}{2}$ kg/m²) or resin system shall be applied to prepared concrete surface. However, the covering capacity depends on the nature of surface over which the system is being applied and the contractor shall use additional quantity of the resin system as per the recommendation of the manufacturer.

4.5 Handling Precaution

- 4.5.1 Only skilled and experienced workers shall be entrusted with the application of epoxy system. The resin and hardener shall not be allowed to come into direct contact with the skin. Rubber or polythene gloves with cotton gloves underneath must be worn by the workers handling resin products. Parts of skin which have accidentally come into contact with resin or hardener shall immediately be washed with lukewarm water and a mild soap. Special cleaning creams or chemical shall be kept readily available and used as recommended by the manufacturer.

4.6 Cleaning and Maintenance of Equipment

- 4.6.1 Tools and mixing equipment shall be cleaned immediately after use by using scrapers and other solvents (e.g. toluene, xylene or acetone) as recommended by the manufacturer.

5.0 APPROACH, WORKING PLATFORM & SCAFFOLDING

- 5.1 The contractor shall arrange all approaches, stairways, ladders, working platform etc. for carrying out the entire operation safely. The working area shall be neatly maintained and all facilities required by the Engineer-in-Charge for proper supervision of the work shall be provided by the contractor.
- 5.2 All precautionary measures required for the safety of the structure during the progress of operation and till the successful completion and handing over shall be the responsibility of contractor. He shall carry out all such measures as directed by Engineer-in-Charge.

6.0 PAYMENT (applicable to item rate tenders only)

- 6.1 Payment shall be made by weight of resin system actually used in the work.
- 6.2 The rate quoted shall be inclusive of all labour and materials required for the successful completion of the work including all cleaning operation before and after the work, preparation of the old, hardened concrete surface as specified, mixing, application of epoxy resin and other safety measures including their removal after completion, all plants and tools etc. complete. Rate shall also be inclusive of all tests required to check the specific properties of materials.
- 6.3 Any test specified and directed to establish the soundness and monolithicity of bonding of fresh concrete to old concrete actually executed shall be paid separately unless such tests fail to meet the requirements of this specification. In case of failure, no such payment shall be made and the contractor shall repair/ rectify or re-do the work as directed by Engineer-in-Charge at no extra cost to the owner.
- 6.4 Underground work like excavation, backfilling, removal of surplus earth, keeping the pit dry by pumping/ bailing out subsoil water shall be paid separately as per relevant item in the contract.

मानक विनिर्देशन
सिविल एवं संरचनात्मक कार्य

STANDARD SPECIFICATION
CIVIL & STRUCTURAL WORKS

पाडं का डिजाईन
(आर सी सी बीम एवं स्लैब के लिए)

DESIGN OF SCAFFOLDING
(FOR RCC BEAM AND SLAB)

Rev. No	Date	Purpose	Prepared by	Checked by	Standards Committee Convenor	Standards Bureau Chairman	Approved by
2	02-09-2024	REVISED & ISSUED AS SPECIFICATION	AH	AH	AS	MN	<i>Handwritten signature</i>
1	27.08.2018	REVISED & ISSUED AS SPECIFICATION	MA	AS	RS	RKT	
0	27.03.2012	ISSUED AS SPECIFICATION	AH	PJS	SC	DM	



Abbreviations:

C/C	:	Centre to centre distance
IS	:	Indian Standards
NB	:	Nominal bore
RCC	:	Reinforced Cement Concrete
RCM	:	Resident Construction Manager/ Site-in-Charge

Structural Standards Committee

Convenor: Mr. Anurag Sinha

Members: Mr Virender Goel
Mr Sambhu Charan Maity
Mr Deepak Agrawal
Ms Alpana Srivastava
Dr Sudip Paul
Mr Prasenjit Saha *
Mr Charanjit Singh
Mr Ravindra Kumar

* For Fireproofing Specifications

CONTENTS

1.0	SCOPE OF WORK.....	4
2.0	CODES	4
3.0	MATERIAL FOR SCAFFOLDING.....	4
4.0	GENERAL ARRANGEMENT	4
5.0	CONNECTIONS & FITTINGS	5
6.0	DESIGN CONSIDERATION	5
6.1	LOADS	5
6.2	PERMISSIBLE STRESS.....	6
6.3	DEFLECTION.....	6
7.0	MANUFACTURER CERTIFICATE.....	6
8.0	SAFETY PRECAUTION	6
9.0	REUSE AND MAINTENANCE OF SCAFFOLDING	6
10.0	CHECKING OF SCAFFOLDING DURING CONSTRUCTION WORK.....	6
	ANNEXURE-I DETAILS OF SCAFFOLDING.....	6

1.0 SCOPE OF WORK

Purpose of this document is to provide guideline for design of steel scaffolding and staging generally used for supporting the members of formwork system for construction of RCC slab and beams. This document consists of:

- a) Guidelines for design of steel scaffolding (Props/ Staging)
- b) One set of schematic drawing of scaffolding

Contractor has to design the scaffolding arrangement to facilitate the construction. Structural design should be as per section 11 of IS 800 i.e. working stress design method. Design shall meet the specific requirement as mentioned in this document. Contractor has to submit the design calculation to EIL site office for review. However, in case to case basis, RCM/Site-in-Charge (From EIL) may refer the submitted document to EIL design office.

Contractor may follow attached arrangement drawing for scaffolding. In such case, submission of design shall be as per direction of RCM/ Site-in-Charge.

2.0 REFERENCES

2.1 Codes

- IS 226 : Specification for structural steel (Standard Quality).
IS 800 : Code of practice for general construction in steel
IS 806 : Code of practice for use of steel tubes in general building construction
IS 2750 : Specification for steel scaffoldings
IS 4014 (Part I and Part II) : Code of practice for steel tubular scaffolding
IS 14687 : Falsework for concrete structure-Guidelines

2.2 EIL Specifications

- 6-68-0001 : General Scope
6-68-0002 : Materials

3.0 MATERIAL FOR SCAFFOLDING

Steel tubes sections of NB40 conforming to requirement specified in clause No.4.1 of IS 2750 shall be used as vertical members and bracing. Standard available IS rolled section/prefabricated frames (like ACROSPAN or equivalent) shall be used as staging supporting arrangement. Prefabricated frame should conform to requirement as specified in clause No. 7.4 of IS 2750. Material properties of steel sections shall conform to IS 226.

Base plate as indicated in drawing may be used under vertical member. Equivalent alternative arrangement to suit at site may be adopted. Base plate and adjustable base plate arrangement shall conform to requirement specified in clause No. 7.3.11 and 7.3.12 of IS 2750.

4.0 GENERAL ARRANGEMENT

Preferably vertical supporting arrangement shall consist of towers as indicated in the attached drawing (Refer Annexure-I).

Single vertical pipes used as props may be alternative arrangement. Spacing of such props shall be based on design. In no case such spacing shall exceed 1.6 m. All vertical props shall be tied laterally with adjacent members in two orthogonal horizontal directions. C/C distance of such lateral tie member in vertical direction shall not exceed 1.6 m.

At least one bay in such case shall be braced by inclined member. Intention to use this member is to form triangulation, so that lateral force can be safely transferred to base. Inclination of this bracing members with horizontal plane must be $>30^\circ$ but $<55^\circ$. Bracing shall be installed along with progress of formwork to ensure strength and stability at every stage of progress.

Base under vertical support shall be rigid enough to cause uniform pressure distribution. In order to achieve that objective either base plate as shown in drawing or alternative arrangement to suit at site shall be adopted.

5.0 CONNECTIONS & FITTINGS

Connections to be used for height adjustment purpose (marked as adjustable parts in drawing), shall be pin/bolted type connection. Alternate arrangement which shall capable to provide mechanical locking type may also be adopted.

In case of alternative arrangement designed/purchased by contractor, steel Fitting (coupler, joint pin, and putlog etc.) shall conform the requirement mentioned in clause No. 7.3.1 to 7.3.10 and clause No. 4.2 of IS 2750.

6.0 DESIGN CONSIDERATION

6.1 Loads

In addition to clause No. 7.3 of IS 14687 loads and combination of loads as mentioned hereunder shall strictly be followed.

6.1.1 Dead Load

It includes self weight of formwork, and any ancillary temporary work connected or supported by formwork. Additional weight of fitting shall be included in the self weight calculation.

6.1.2 Imposed Load

Load during constructional operation shall constitute the imposed loads. Such load may occur due to construction person, plants and equipments, vibration and impacts of machine delivering concrete, concentrated load, storage of construction materials and unsymmetrical placement of concrete. In no case it shall be considered less than 2 KN/m^2 .

Load due to wet concrete shall be included under imposed load. Unit weight of wet concrete shall be considered as 26 KN/m^2 for load calculation purpose. Concrete should not be dropped from a free height greater than 1.1 m, nor should be allowed to accumulate on the formwork to a height more than three times the thickness of the slab, with a limit in area of 1 m^2 . For any such situation if it be necessary to exceed these limitations, allowances for the additional loading should be considered in design. Accumulation of fresh concrete during construction shall be allowed only at pre planned locations.

6.1.3 Environmental Load

These loads include Wind load, Earthquake load and Snow load. Load shall be calculated as per relevant code (IS: 875/IS: 1893). Lateral force due to wind or seismic force shall subject to a minimum horizontal load amounts to 3% of vertical load. Shrinkage and early thermal movements in the freshly placed concrete should be assessed and accommodated in the design of formwork.

Where supports cannot be fixed vertically due to any reason, the eccentricity of the loading so carried should also be taken into account as per clause No. 5.1.2 of IS 2750.

Design criteria as written in clause No. 5.1 to clause No. 5.2 of IS 2750 shall also be followed in addition to this clause.

6.2 Permissible stress

Permissible stresses shall be as per IS 800 in case of rolled section or IS 806 for tubular section. Bending and shear stress shall be checked for DL and combined action of DL, LL and environmental loads at all critical sections. In case of reusable components of steel, timber, etc, the values of permissible stresses shall be suitably reduced depending upon the number of uses and extent of deterioration as per guideline stipulated in clause No. 7.4.4 of IS 14687. Bearing Pressure on soil under base plate/ base shall not exceed 50 KN/m².

6.3 Deflection

In addition to deflection limit stipulated in clause No. 7.5 of IS 14687, vertical deflection (of members marked as ISMB150 or ISMC75 in drawing) should be limited to 12 mm or L/300, whichever is less (where L is the span length of the staging member).

7.0 MANUFACTURER CERTIFICATE

Manufacturer certificate with respect to steel tubes, fittings and prefabricated frames whenever asked by RCM/ Site- in- Charge shall be submitted as per guideline stipulated in clause No. 6 of IS 2750.

8.0 SAFETY PRECAUTIONS

Safety provisions should be considered as per clause No. 9.1 of IS 14687

9.0 REUSE AND MAINTENANCE OF SCAFFOLDING

Scaffolding which are to be reused shall be carefully cleaned and properly repaired between uses. Concrete or mortar film sticking to the form or the joining surface shall be completely removed after each use.

Formwork material shall be properly stored. The component shall be cleaned and painted periodically.

Threaded parts shall be oiled greased after thorough clearing and removal of dirt or slurry. Free movement of the telescopic components shall be ensured by periodic cleaning/oiling.

10.0 CHECKING OF SCAFFOLDING DURING CONSTRUCTION WORK

Formal checking as per clause No. 9.8 of IS 14687 should be exercised at site before and during concreting work. A filled watcher report as applicable to this specification as per Appendix-C of IS 14687 should be submitted by the contractor.

DETAILS OF SCAFFOLDING

ANNEXURE-I (Sh.1of 5)

- NOTES:-
1. ALL DIMENSIONS ARE IN MM.
 2. THIS ARRANGEMENT IS PREPARED FOR SLAB THICKNESS UPTO 200MM WITH LIFT HEIGHTS UPTO 10.000M.
 3. STAGING HAS BEEN DESIGNED ASSUMING BEARING CAPACITY OF FINISHED FLOOR/SUBGRADE/INFILL TO 5T/M. 2
 4. ERECTION OF STAGING SHALL START WITH CENTRE LINE OF BEAM.
 5. LOCATIONS WHERE ACCUMULATION OF CONCRETE IS EXPECTED DURING CONCRETING WORK THE SPACING OF CROSS BEAMS(MC75) SHALL BE REDUCED TO 250MM C/C.
 6. IN NO CASE HEIGHT OF ACCUMULATED CONCRETE SHALL BE MORE THAN 750mm.

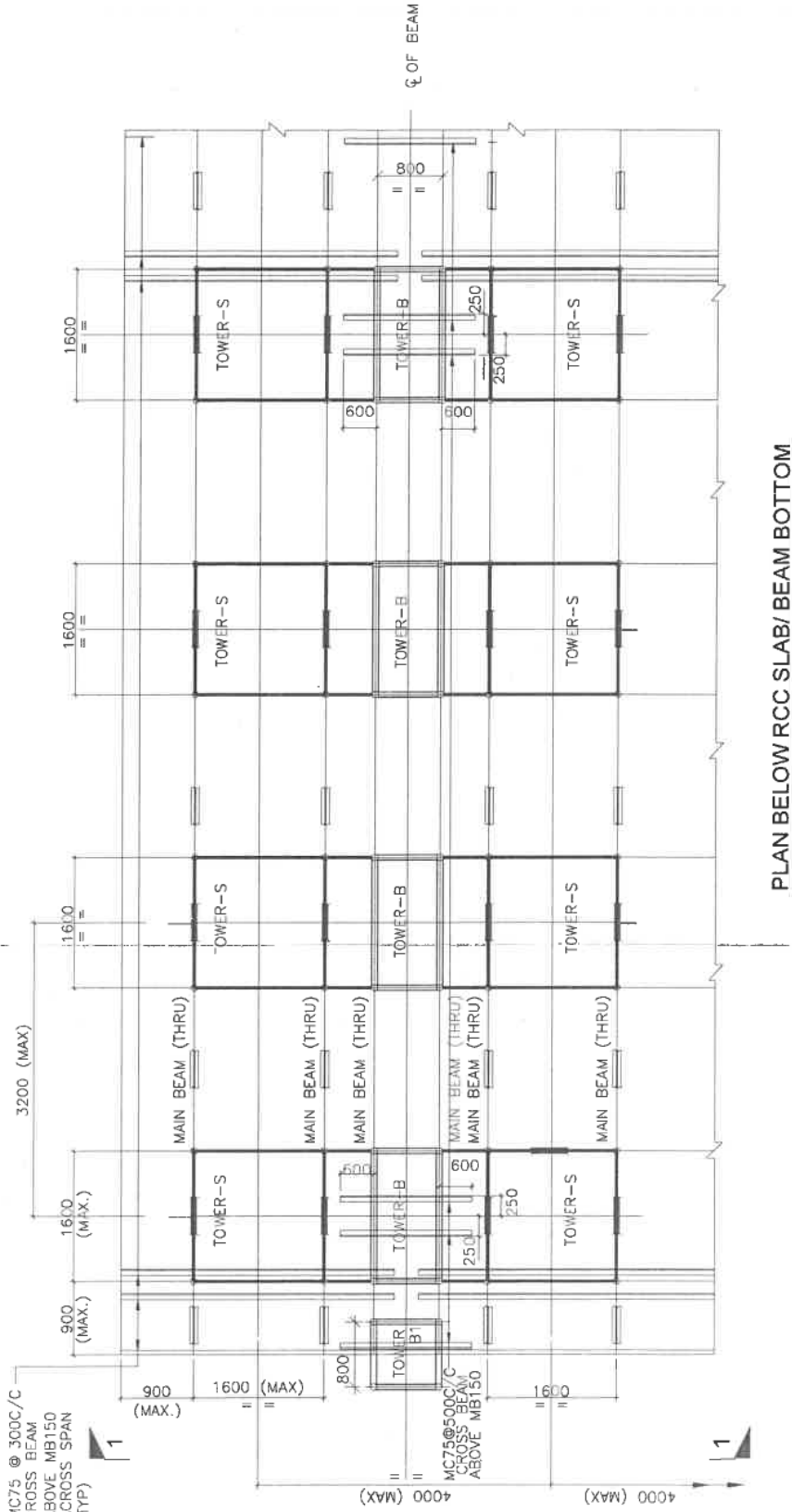

ANNEXURE-I (Sh.2 of 5)

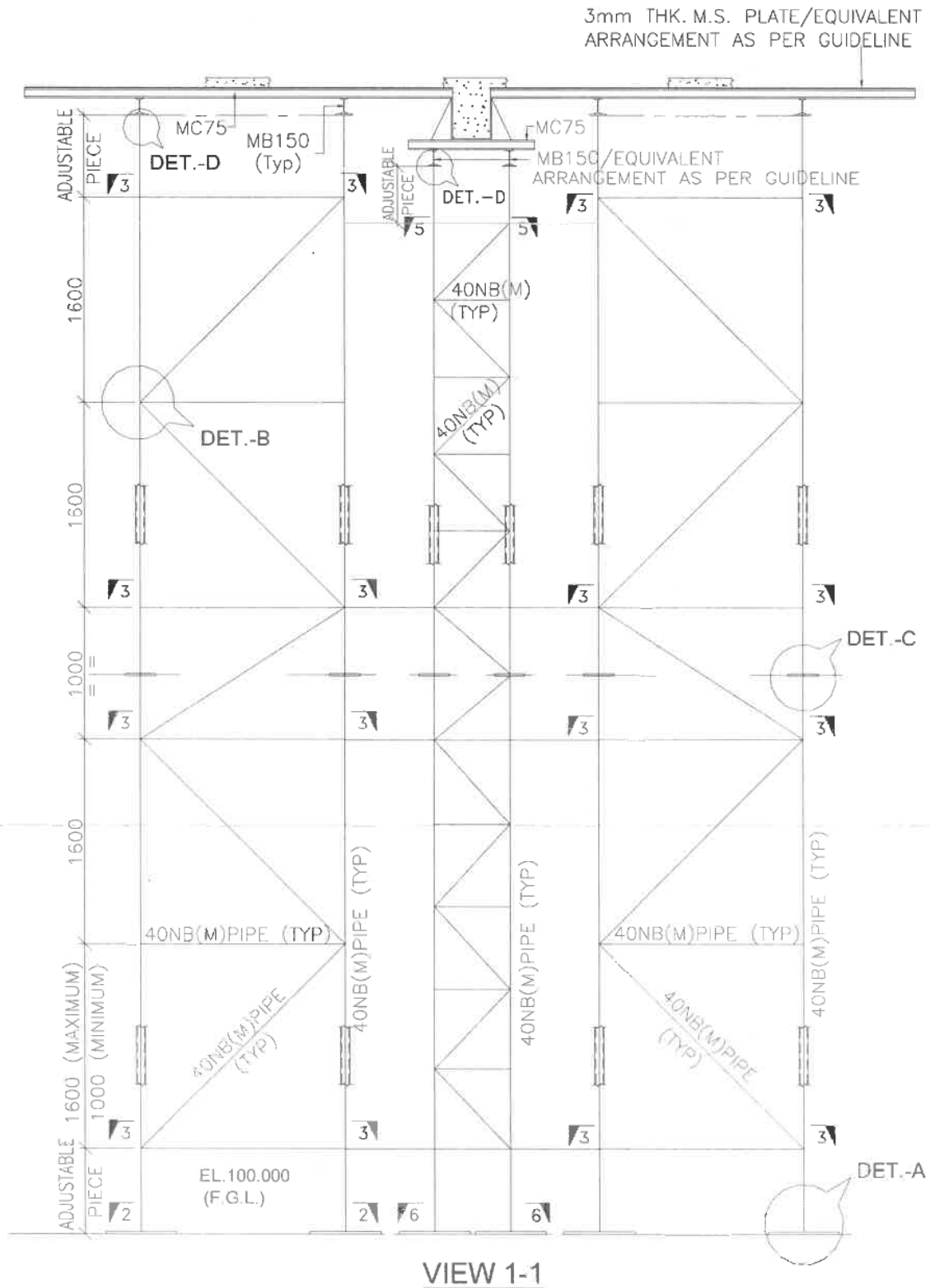

ANNEXURE-I (Sh.3 of 5)

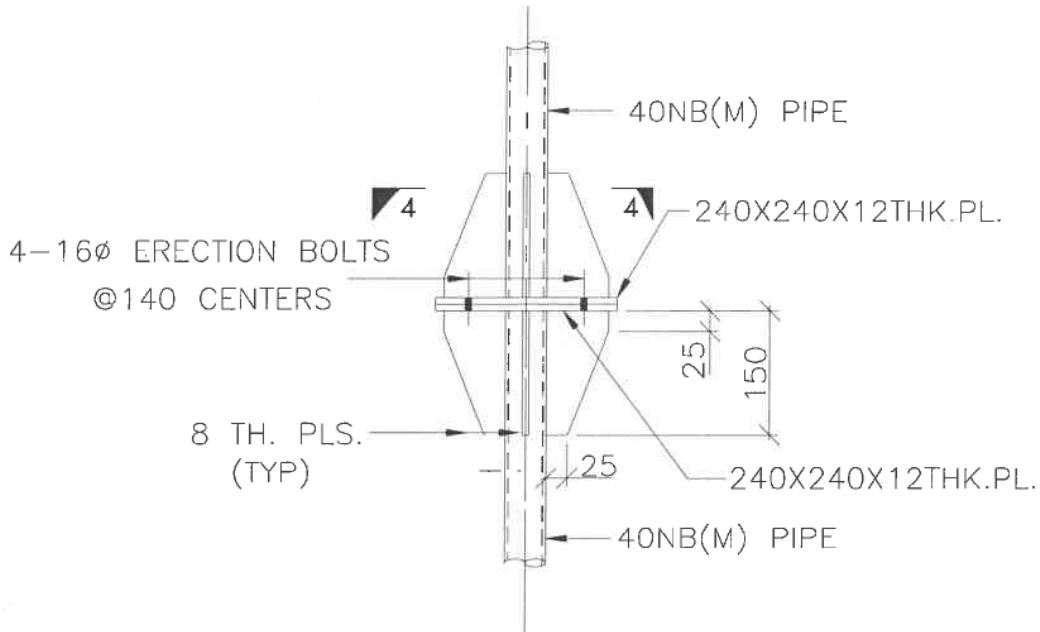

DETAIL-C

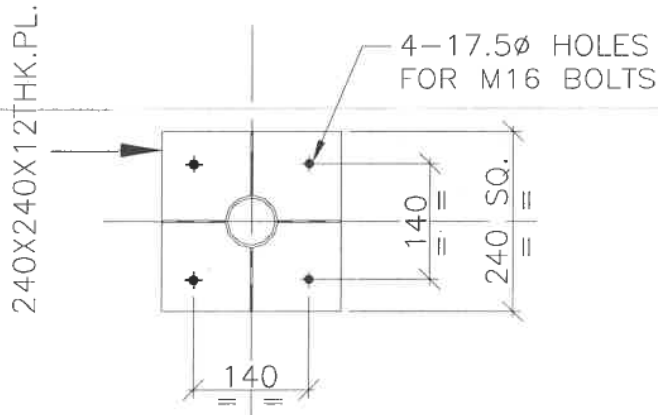

VIEW 4-4

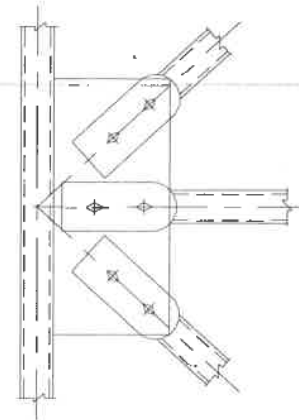

DETAIL-B

ANNEXURE-I (Sh.4 of 5)

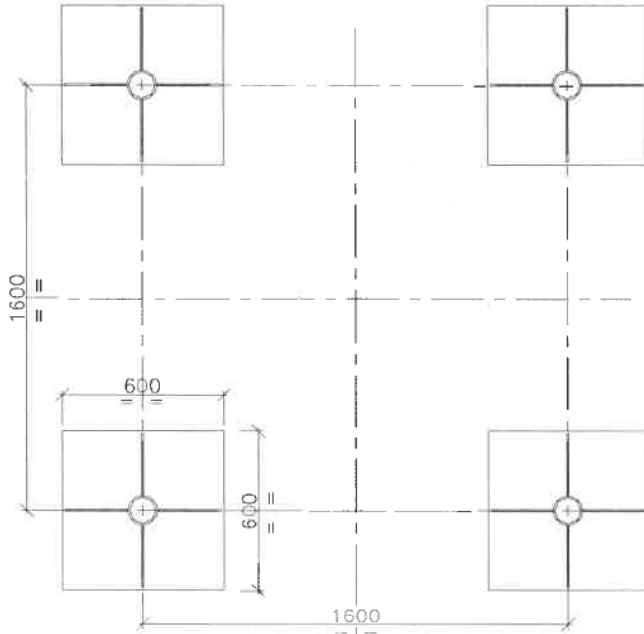

**VIEW 2-2
PLAN OF BASE PLATE**

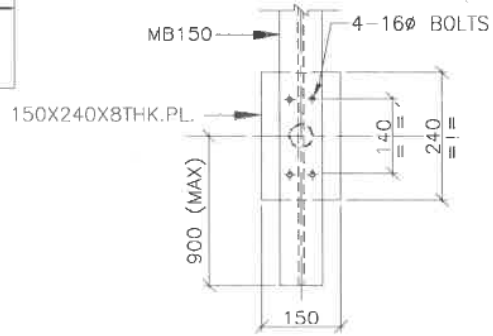

VIEW 7-7



VIEW 3-3

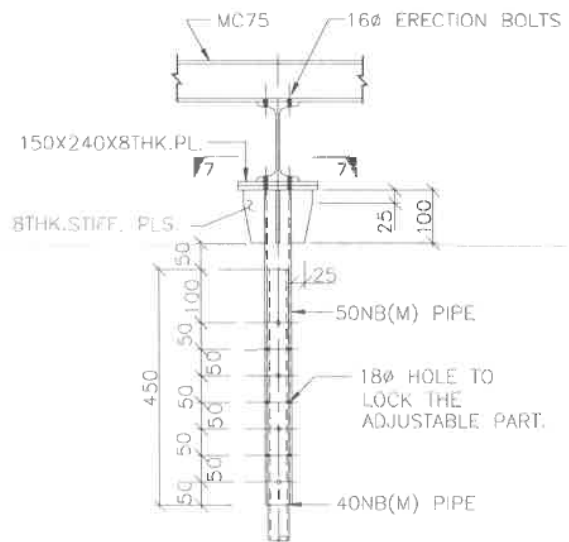

**DETAIL-D
SIMILAR FOR TOWER-S, B & B1**

ANNEXURE-I (Sh.5 of 5)

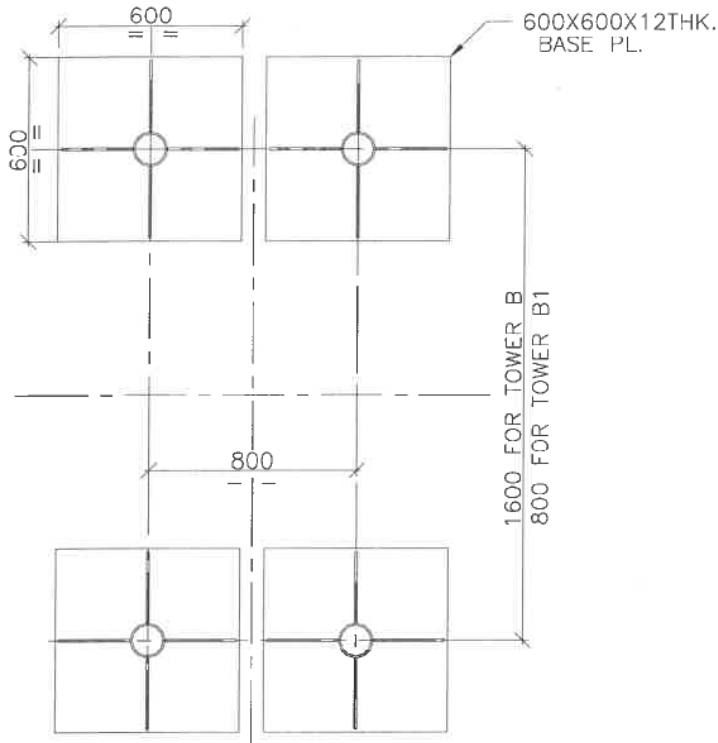

**VIEW 6-6
FOR TOWER B & B1**

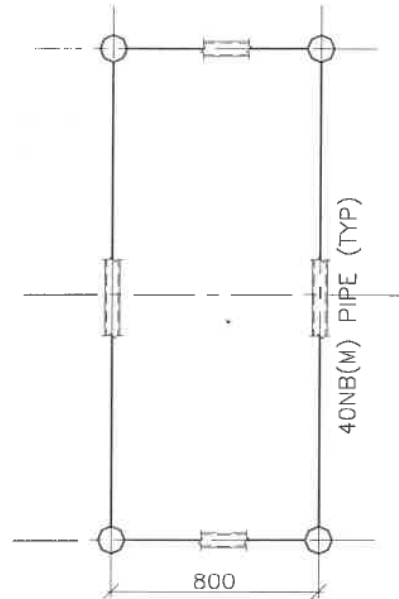

**VIEW 5-5
FOR TOWER B & B1**

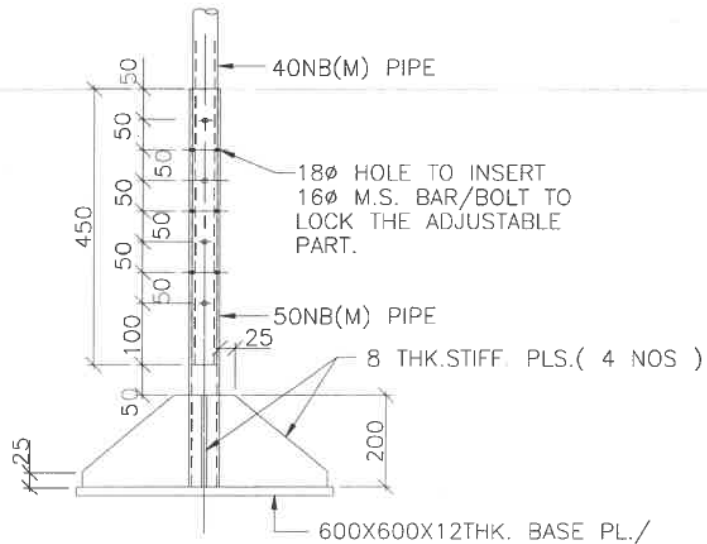

**DETAIL-A
SIMILAR FOR TOWER-S, B & B1**

वास्तुकला कार्या- के लिए
मानक विनिर्देश
सामान्य टिप्पणियाँ

STANDARD SPECIFICATIONS
FOR
ARCHITECTURAL WORKS
(GENERAL)

7	08.02.22	REAFFIRMED AND ISSUED AS STANDARD SPECIFICATION	ANISH MAHALA	ANISH KUNDU	SAMIR DAS	SANJAY MAZUMDAR
6	20.03.17	REAFFIRMED AND ISSUED AS STANDARD SPECIFICATION	PD	JS/ JKB	R. SRIVASTAVA	R.NANDA
5	15.03.12	REVISED AND ISSUED AS STANDARD SPECIFICATION	PD	SD	JKB	D. MALHOTRA
4	21.03.07	RENAMED & ISSUED AS STANDARD SPECIFICATION	SD	JKB	ARVIND KUMAR	V. CHATURVE
3	11.03.99	REAFFIRMED AS STANDARD SPECIFICATION	SD	MLB	SCJ	AS
Rev. No	Date	Purpose	Prepared by	Checked by	Standards Committee Convener	Standards Bureau Chairman
						Approved by

Abbreviations:

ASTM :	American Society for Testing and Materials
BS :	British Standards
BIS :	Bureau of Indian Standards

Structural Standards Committee

Convener: Mr. Samir Das

Members: Mr. Rajesh Gujral
Mr. Anish Kundu
Mr. Sandeep Sharma
Mr. Maitrayee Majumder (Strl)
Mr. Charanjeet Singh (Projects)
Mr. Ravindra Kumar (Construction)

CONTENTS

1.0	GENERAL.....	4
2.0	DEFINITIONS	4
3.0	CODES & SPECIFICATIONS	4
4.0	MANUFACTURER	4
5.0	CONFLICTS & CONTRADICTIONS	5
6.0	MATERIALS	5
7.0	WORKMANSHIP.....	6
8.0	PACKAGING, SHIPPING, DELIVERY & STORAGE	6
9.0	SUBMITTALS	6
10.0	MEASUREMENT.....	7

1.0 GENERAL

This specification establishes and defines various aspects of specifications of Architectural works such as codes, references, manufacturer, conflicts and contradictions, materials, workmanship, packaging, shipping, delivery and storage, testing, submittals and measurement etc. and shall be applicable for all the Architectural specifications.

2.0 DEFINITIONS

2.1 Contractor

The party which carries out all or part of the design, engineering, procurement, construction, commissioning or management of the Project. Contractor includes its approved Manufacturers, Vendors, Suppliers, and subcontractor's. Requirements of this specification shall be enforced at all levels of the Contractor's design, engineering, procurement, construction process.

2.2 Subcontractor

The party which is engaged by the "Contractor" and carries out all or part of the design, engineering, procurement, construction of the system (s).

2.3 Manufacturer/ Supplier/ Vendor

The party which manufactures and/or supplies equipment, materials, technical documents/ drawings and services to perform the duties specified by the "Contractor".

2.4 Shall

Indicates a mandatory requirement.

2.5 Should

Indicates a strong recommendation to comply with the requirements of this document.

3.0 CODES & SPECIFICATIONS

3.1 Codes and standards as indicated in the specifications form a part of specifications. When an edition date is not indicated for a code or standard, the latest edition and addendum or amendment in force at time of contract award shall apply.

3.2 Alternate codes and standards meeting the requirements of the referenced codes and standards may be used with the approval of the competent authority.

3.3 It shall be Contractor's responsibility to be, or to become, knowledgeable of the requirements of any referenced codes and standards.

4.0 MANUFACTURER

4.1 Name of the Manufacturers of products included in the tender documents are the acceptable Manufacturers for the particular product provided the products meet the requirements specified in the tender documents. Products by other Manufacturers which are of equal quality and performance and meet the specified requirements may be considered for approval upon review of information as required and submitted to the competent authority. However the contractor to ensure that the time schedule is adhered to in any case.

- 4.2 Product data sheet, specifications, performance data, installation instructions and other recommendations of such approved Manufacturers also form part of the specifications provided that these are not in contradiction with other specified requirements.
- 4.3 Materials, installation method and other requirements for execution of any item if required by Manufacturer's installation instructions, recommendations and requirements shall also form part of the specifications whether specified or not.
- 4.4 In case, name of particular Manufacturers are mentioned in specification/ drawing/ item descriptions etc. the purpose is to set example of desired quality of the product. Product of other manufacturers having similar quality (in the opinion of Engineer-in-Charge) may also be considered.

5.0 CONFLICTS & CONTRADICTIONS

- 5.1 Specifications, Scope of Work, Schedule of rates and drawings for a particular Tender shall be read in conjunction with each other. In case of conflicts/ contradictions amongst them, the clarification shall be obtained from the Engineer-In-Charge whose decision shall be final & binding. Following procedure shall be followed for the necessary clarification.
- 5.2 Item description shall prevail over specifications for item rate tenders when provisions therein are different from those in specifications. Whenever any requirement is not covered in item description but are covered in specifications, the specifications shall be followed in addition to the requirements of item description. No extra payment shall be made to the Contractor for executing such item as per specification.
- 5.3 Whenever drawings call for requirements different from or additional to those in item description and specification, the decision of the Engineer-In-Charge shall be obtained in writing. However no extra payment shall be made to the Contractor for executing any work incorporating requirements additional to those in item description and specification but covered in applicable drawings or standards attached to the tender.
- 5.4 Any conflict between drawing, item description, specification etc. shall be got resolved by the Contractor from the Engineer-In-charge in writing before execution.

6.0 MATERIALS

- 6.1 All materials shall be of standard quality conforming to the specifications and other requirements of tender document and shall be obtained from the approved Manufacturer.
- 6.2 The Contractor shall get the samples of materials approved by the Engineer-In-Charge before ordering & procurement. Such approved samples shall be properly marked/ identified as approved sample and shall be kept as record for future reference.
- 6.3 Contractor shall arrange the samples along with necessary documentation, test certificates etc. so that the compliance with the specifications etc. can be ascertained.
- 6.4 Contractor shall arrange mock-ups if asked by the Engineer-In-Charge to facilitate approval of the samples.
- 6.5 Samples shall be approved subjected to compliance with specifications etc. Finishing, colour, texture and other aesthetic aspects shall also be considered for finishing/ interior items.
- 6.6 Contractor shall get the materials tested from approved test house if and as asked by the Engineer-In-Charge & submit the test certificate at his own cost for which no extra payment shall be made to him.

6.7 The Engineer-In-Charge shall have the right to reject all or any of the materials intended to be used and such materials shall be immediately removed from the site by the Contractor at his own cost without any claim for compensation etc. due to such rejection.

7.0 WORKMANSHIP

7.1 Workmanship shall be in accordance with relevant codes or in accordance with Manufacturer's recommendations as approved by the Engineer-in-charge if not specified otherwise.

7.2 All work shall be executed to the complete satisfaction of the Engineer-in-charge. Necessary rectification etc. shall be done by the Contractor at no extra cost for works not accepted by the Engineer-in-charge until the work is accepted by him.

7.3 All works shall be done by qualified Contractors who have adequate equipment and skilled workers. All specialized items of work (e.g. Aluminium Doors and Windows, Waterproofing, Underdeck and Overdeck Insulation, roof sheeting/ cladding, False ceiling, False Flooring, Partitioning and Panelling, Expansion joint sealing, Fire Check Doors, Structural Glazing, Aluminium Composite Panels etc.) shall be got executed by the Contractor only through authorised applicators/ sub contractors of approved Manufacturer/ vendor or as approved by the Engineer-In-Charge.

7.4 All precaution and protection shall be taken during & after completion of work to prevent damages to work being done and other works. Any damages done shall be rectified by the Contractor at no extra cost.

7.5 Work area shall be cleaned after completion of each work and shall be kept clean and protected till final acceptance by the competent authority.

8.0 PACKAGING, SHIPPING, DELIVERY & STORAGE

8.1 All material shall be delivered in Manufacturer's original package bearing the name of the Manufacturer, product colour and pattern name, identification number and other related information.

8.2 All materials shall be stored, preserved and protected to safeguard against all adverse environments such as humidity, moisture, rain, dust, dirt, sand, mud, salt air, salt spray and sea water.

8.3 Specific requirement of packaging, shipping, storage and preservation and safety of materials/ items if any as per Manufacturer's recommendation shall also be ensured by Contractor.

8.4 Materials damaged in handling and storage shall not be used. In the event that any material for use deteriorates and become unusable due to inadequate and poor storage they shall be removed from site as instructed by Engineer-in-charge and replaced at the Contractor's expenses.

9.0 SUBMITTALS

If not mentioned otherwise, Contractor shall submit the following.

9.1 Samples

9.1.1 Samples of materials, components, accessories and complete range of finishing/ shades/ colours for verification as well as acceptance of pattern, colour and finish as applicable.

9.1.2 Samples shall be re-submitted until approved. Approved samples shall be retained as mentioned in clause 6.0

9.2 Test and BIS Certificates

9.2.1 All applicable tests shall be conducted by the Contractor at no extra cost. Test Certificates shall be submitted for review/ approval of the Engineer-in-charge.

9.3 Shop/ fabrication Drawings

9.3.1 Shop or fabrication drawings indicating large scale details, lay-out, connections, anchoring, fastening, bracing, finishes etc. as applicable for review/ approval.

9.3.2 These drawings shall be prepared to achieve the desired design and quality of work expressed in design, drawings and specifications etc..

9.4 Product Information and Manuals

- A. Product information (Technical).
- B. Manufacturer's recommended installation instructions.

9.5 List of applicators/ Sub contractors

Contractor shall submit list of applicators/ sub contractors of specialized items of works along with there past track report for review/ approval before execution of such items.

9.6 Maintenance manuals

In case of specialized items, contractor shall submit the Operation & maintenance manual including guarantee/warranty card and its validity document.

9.7 Deviations

9.7.1 Deviations if any shall be raised and processed in accordance with conditions mentioned in the tender document.

9.7.2 Deviations shall be submitted before procurement and execution. Procurement, execution and other related works shall be taken up only after the deviation is accepted by the Engineer-In-Charge. Post facto approval of deviation shall not be entertained and Contractor himself shall be responsible for any procurement/ execution of any work or any action which are deviations and for whose, prior approval is not obtained.

9.8 Sample mock-up work

Contractor shall prepare mock-up work of specialized items or systems as specified or asked by the Engineer-In- Charge. Mock-up shall include the complete item or system with all associated items.

10.0 MEASUREMENT

Mode of measurement is generally specified in each Specification. Whenever mode of measurement is not specified, IS: 1200 shall be applicable.

फ़र्श के परिष्करण के लिए
मानक विनिर्देश

STANDARD SPECIFICATION
FOR
FLOOR FINISHING

7	01.06.20	REVISED & ISSUED AS STANDARD SPECIFICATION	Anish Mahala	Samir Das	Rajanji Srivastava	Sunil Kumar Saxena
6	03.03.15	REVISED & ISSUED AS STANDARD SPECIFICATION	AM	SD	JKB	PKM (Addn GM) S CHANDA
5	06.07.10	REVISED & ISSUED AS STANDARD SPECIFICATION	GB	JS	JKB	VK N. DUARI
4	21.03.07	REVISED & ISSUED AS STANDARD SPECIFICATION	SD	JKB	ARVIND KUMAR	V. CHATURVEDI
3	12.03.99	REAFFIRMED AS STANDARD SPECIFICATION	SD	MLB	SCJ	AS
2	16.03.94	REVISED & ISSUED AS STANDARD SPECIFICATION	JS	JS	AKG	AS
Rev. No	Date	Purpose	Prepared by	Checked by	Standards Committee Convenor	GM (E) Approved by
						Standards Bureau Chairman



Abbreviations:

ASTM :	American Society for Testing and Materials
BS :	British Standards
IS :	Indian Standards
PVC :	Polyvinyl Chloride

Structural Standards Committee

Convener: Mr. Rajanji Srivastava

Members: Mr. Anurag Sinha
Mr. VK Panwar
Mr. Samir Das
Mr. Amitabh Kishore
Mr. Gyasuddin
Mr. Charanjit Singh (Projects)
Mr. Ravindra Kumar (Construction)

CONTENTS

1.0	GENERAL	4
2.0	CEMENT CONCRETE FLOORING.....	5
3.0	HEAVY DUTY CEMENT CONCRETE FLOORING.....	6
4.0	CEMENT PLASTER SKIRTING.....	6
5.0	CERAMIC & VITRIFIED TILE FLOORING.....	7
6.0	ACID OR ALKALI RESISTANT TILES.....	9
7.0	MARBLE STONE FINISH.....	10
8.0	KOTA STONE FINISH	12
9.0	GRANITE STONE FINISH.....	15
10.0	PVC FINISH	17
11.0	ABRASION RESISTANT EPOXY FLOOR COATING SYSTEM	18
12.0	ABRASION & IMPACT RESISTANT POLYURETHANE CONCRETE FLOOR COATING SYSTEM.....	20
13.0	CHEMICAL RESISTANT NOVOLAC EPOXY FLOOR COATING SYSTEM	23
14.0	CHEMICAL RESISTANT NOVOLAC EPOXY WALL COATING SYSTEM.....	26
15.0	MEASUREMENTS.....	28

1.0 GENERAL

This specification covers technical specification of various kind of floor finishes/ floorings to be used in building works.

1.1 Standards

Reference shall be made to the following Indian Standards for any further information etc. not covered in this specification.

IS: 2571	Code of practice for laying in situ cement concrete flooring.
IS: 3461	Specification for PVC asbestos floor tiles.
IS: 3462	Specification for unbaked flexible PVC flooring.
IS: 4441	Code of practice for use of resin type chemical resistant mortars.
IS: 4443	Code of practice for use of resin type chemical resistant mortars.
IS: 4457	Acid and/or alkali Resistant tiles.
IS: 4631	Code of practice for laying of epoxy resin floor toppings.
IS: 5318	Code of practice for laying of flexible PVC sheet and tile flooring.
IS: 5491	Code of practice for laying of in-situ granolithic concrete floor topping.
IS: 13630 (Part-1 to 15)	Methods of Testing of ceramic tiles, methods of test, sampling and basis for acceptance
IS 13712	Specification for ceramic tiles; definition, classification characteristic and marking.
IS 15622	Pressed ceramic tile - specification

Note: Wherever, codes other than IS codes are mentioned, equivalent IS codes are also acceptable.

1.2 Base/ sub base for floor finishing

Floor finishing shall be provided over base/ sub base of cement concrete or reinforced cement concrete (RCC) floor slab. In case of ground floor, the floor slab i.e. base/ sub base for floor finish shall be as per standard no. 7-67-0011 or as specified or as mentioned in drawings. For other upper floors, the floor slabs shall be the base/ sub base for floor finish.

1.3 Slope/ levelling of floor finishing

1.3.1 Finished floor shall be in slope towards drainage out-lets. Slope shall be ranging from 1: 48 to 60 or as directed by Engineer-In-Charge in Verandahs, Courtyards, Kitchen, Bath and other wet areas. Slope in Indian type water closet areas shall be 1:30 or as directed by Engineer-In-Charge. Further, necessary drop in flooring in bath, WC, kitchen near floor traps ranging from 6mm to 10mm will also be provided to avoid spread of water.

1.3.2 Necessary margin to accommodate these slopes and drops shall preferably be made in base/ sub base or base course of finishing layer.

1.3.3 Excepting above and if not mentioned specifically otherwise, top of floor finish of all areas/ rooms/ spaces in any particular floor shall be same throughout. If further filling on base floor slab is required for this purpose, the filling shall be done with cement concrete (1 cement: 2

coarse sand: 4 graded stone aggregate, 20mm nominal size which shall be carried out in accordance with workmanship mentioned in the specification of cement concrete flooring for base course of cement concrete flooring) or cement mortar (1 cement: 3 coarse sand) as directed by Engineer-In-Charge.

1.4 Skirting

Skirting shall be provided with floor finish. If not mentioned otherwise skirting shall be of same finish as that of the flooring.

2.0 CEMENT CONCRETE FLOORING

2.1 General

Cement concrete flooring shall consist of a base course of cement concrete (laid over sub base/ base concrete floor) and a finishing layer.

2.2 Base course

Base course shall be of 40mm thick cement concrete (1 cement: 2 coarse sand: 4 graded stone aggregate, 20mm nominal size).

2.3 Finishing layer

Finishing layer shall be a floating coat of neat cement, including cement slurry (@ 2 kg of cement for area of one square metre).

2.4 Workmanship

2.4.1 The surface of floor slab shall be roughened with steel wire brushes without disturbing the concrete, cleaned, and the laitance shall be removed. Immediately before laying the floor finish, the base shall be wetted and a coat of cement slurry @ 2 kg of cement spread over an area of one square metre so as to get a good bond between the floor slab and base course.

2.4.2 Floor finish of specified thickness shall be laid in the pattern including the border as given in the drawings or as directed by the Engineer-in-Charge. The border panels shall not exceed 450mm in width and the joints in the border shall be in line with panel joints. The panels shall be of uniform size and no dimension of a panel shall exceed 2 metre and the area of a panel shall not be more than 2 square metre. The joints of borders at corners shall be mitred for provision of strips.

2.4.3 Cement concrete floor finish shall be laid in one operation using glass/ aluminium/ PVC/ brass / stainless steel or any other strips (as specified or as per instructions of the Engineer-in-Charge) at the junction of two panels to ensure uniformity in colour of all the panels and straightness at the junction of the panels. The strips shall be fixed with their tops at proper level, giving required slopes.

If, type of strip is not specified anywhere, minimum 3mm thick PVC strips shall be provided.

2.4.4 Base course of cement concrete shall be placed in the panels and be levelled with the help of straight edge and trowel and beaten with thapy or mason's trowel. The blows shall be fairly heavy in the beginning but as consolidation takes place, light rapid strokes shall be given. Beating shall cease as soon as the surface is found covered with a thin layer of cream of mortar. The evenness of the surface shall be tested with straight edge. Surface of flooring shall be true to required slopes. While laying concrete, care shall be taken to see that the strips are not damaged/disturbed. The tops of strips shall be visible clearly after finishing with cement slurry.

2.4.5 The finishing layer of the floor finish shall follow immediately after the cessation of beating. The surface shall be left for some time, till moisture disappears from it or surplus water can be mopped up. Use of dry cement or cement and sand mixture stiffening the concrete to absorb excessive moisture shall not be permitted. Excessive trowelling shall be avoided. Fresh cement shall be mixed with water to form thick slurry and spread @ 2 kg of cement over an area of 1 sqm of flooring while the flooring concrete is still green. The cement slurry shall then be properly processed and finished smooth.

2.4.6 The junctions of floor with wall plaster, dado or skirting shall be rounded off.

2.4.7 The curing shall be done for a minimum period of ten days. Curing shall not be commenced until the top layer has hardened. Covering with empty gunnies bag shall be avoided as the colour of the flooring is likely to be bleached due to the remnants of cement dust from the bags.

3.0 HEAVY DUTY CEMENT CONCRETE FLOORING

3.1 General

Heavy duty cement concrete flooring shall consist of a base course of cement concrete (laid over sub base/ base concrete floor) and a finishing layer.

3.2 Base Course

Base course shall be of 40mm thick cement concrete (1 cement: 2 coarse sand: 4 graded stone aggregate, 20mm nominal size).

3.3 Finishing layer

Finishing layer shall be of 12mm thick cement hardener consisting of mix 1:2 (1 cement hardener mix: 2 graded stone aggregate 6mm nominal size) by volume laid over the base course.

Hardener/ hardening compound shall be mixed @ 2 litre per 50 kg of cement or as per Manufacturer's specifications.

3.4 Workmanship

3.4.1 Base course shall be laid in accordance with clause nos 2.4.1, 2.4.2, 2.4.3 & 2.4.4

3.4.2 The top surface of base course shall be roughened with brushes while the concrete is still green and the forms/strips shall be kept projecting up 12mm over the concrete surface, to receive finishing layer.

3.4.3 The topping shall be laid on base course within 2 to 4 hours of its laying, true to provide a uniform and even surface. It shall be firmly pressed into the bottom concrete so as to have good bond with it. After the initial set has started, the surface shall be finished smooth and true to slope with steel floats.

3.4.4 The junctions of floor with wall plaster, dado or skirting shall be rounded off.

3.4.4 The curing shall be done for a minimum period of ten days. Curing shall not be commenced until the top layer has hardened. Covering with empty gunnies bag shall be avoided as the colour of the flooring is likely to be bleached due to the remnants of cement dust from the bags.

4.0 CEMENT PLASTER SKIRTING

4.1 General

Cement plaster skirting shall be provided in cases of all types of cement concrete floorings if not mentioned otherwise.

Cement plaster skirting shall be with cement mortar 1:3 (1 cement: 3 coarse sand) finished with floating coat/ slurry of neat cement. The cement to be applied in the form of slurry for smooth finishing shall be at the rate of 2 kg of cement per litre of water applied over an area of 1 sqm.

Average thickness of cement plaster skirting shall not be less than 18mm.

If not mentioned otherwise, height of the skirting shall be 125mm.

4.2 Workmanship

4.2.1 The surface on which the skirting is to be applied shall be prepared for laying skirting. The joints shall be raked out to a depth of at least 15mm in masonry walls. In case of concrete walls, the surfaces shall be roughened by hacking. The surface shall be cleaned thoroughly, washed with water and kept wet before skirting is commenced.

4.2.2 Skirting shall be laid immediately after the surface is prepared. It shall be laid along with the border or adjacent panels of floor. The joints in skirting shall be kept true and straight in continuation of the line of joints in borders or adjacent panels. The skirting shall be finished smooth with top truly horizontal and joints truly vertical except where otherwise indicated.

4.2.3 The finishing of surface shall be done simultaneously with the borders or the adjacent panels of floor. Where skirting is flush with plaster, a groove 10mm wide and upto 5mm deep shall be provided in plaster at the junction of skirting with plaster.

4.2.4 Curing shall be commenced on the next day of plastering when the plaster has hardened sufficiently and shall be continued for a minimum period of 7 days.

5.0 CERAMIC & VITRIFIED TILE FLOORING

5.1 Ceramic Tile

5.1.1 Ceramic Tiles shall conform to IS 15622 and shall be of 1st quality, flat, true to shape and free from blisters crazing, chips, welts, crawling or other imperfections detracting from their appearance.

5.1.2 Classification and Characteristics of pressed ceramic tiles shall be as per IS 13712.

5.1.3 The tiles shall be tested as per IS 13630.

5.1.4 The tiles shall conform to table 10 of IS 15622 with water absorption 3 to 6% (Group BII).

5.1.5 The top surface of the tiles shall be glazed. Glaze shall be either glossy or matt as specified. The underside of the tiles shall not have glaze on more than 5% of the area in order that the tile may adhere properly to the base. The edges of the tiles shall be preferably free from glaze. However, any glaze if unavoidable, shall be permissible on only upto 50 per cent of the surface area of the edges.

5.1.6 The tiles shall be non-slip type for flooring application in wet areas and of colour and pattern as specified in drawings, Item descriptions, job specification, design basis or approved by Engineer-in-Charge.

5.1.7 If not mentioned elsewhere i.e. drawings, Item descriptions, job specification, design basis etc. sizes of the tiles shall be:

Flooring	: 300mm x 300mm
Dado	: 300mm x 450mm
Thickness	: As specified by the Manufacturer.

5.2 Vitrified Tiles

5.2.1 Specification of vitrified tiles shall be similar to 5.1 excepting following specifications which vitrified tiles shall conform.

5.2.2 The tiles shall conform to Table 12 of IS 15622 (Tiles with water absorption less than 0.08 per cent, Group BIa).

5.2.3 Sizes of the tiles shall be as per drawings/ Item descriptions/ job specification/ design basis etc. as directed by Engineer-In-Charge. Thickness shall be as specified by the Manufacturer.

5.2.4 If not mentioned elsewhere i.e. drawings, Item descriptions, job specification, design basis etc. 600mm x 600mm glazed tiles finished with digital printing shall be used.

5.3 Workmanship

The finished surface shall not sound hollow when tapped with a wooden mallet.

The tiles shall be laid in pattern as per drawing.

5.3.1 Base concrete or the RCC slab or plastered wall surface on which the tiles are to be laid shall be cleaned, wetted and mopped.

5.3.2 The tiles shall be laid over a coating of polymer modified, thin set, quick set tile adhesive conforming to IS 15477. The adhesive shall be thoroughly mixed with water and a paste of zero slump shall be prepared so that it can be used within 1.5 to 2 hours. It shall be spread over an area not more than one sqm at one time. Average thickness of adhesive shall be 3mm. The adhesive so spread shall be combed using suitable trowel. Tiles shall be pressed firmly in to the position with slight twisting action checking it simultaneously to ensure good contact gently being tapped with wooden mallet till it is properly backed with adjoining tiles. The tiles shall be fixed within 20 minutes of application of adhesive. The surplus adhesive from the joints, surface of the tiles shall be immediately cleaned.

5.3.3 The joints shall be kept as thin as possible and in straight lines or to suit the required pattern.

5.3.4 The surface of the flooring during laying shall be frequently checked with a straight edge about 2 m long, so as to obtain a true surface with the required slope. In bath, toilet W.C. kitchen and balcony/ verandah flooring, suitable tile drop or as shown in drawing will be given in addition to required slope to avoid spread of water. Further tile drop will also be provided near floor trap.

5.3.5 For vertical surfaces, the tiles shall be corrected to proper planes with joints truly vertical in required pattern and butt jointed. The fixing shall be done from bottom upward. The top of skirting and dado shall be truly horizontal.

5.3.6 If not mentioned specifically elsewhere such as design basis, item description, drawings, job specifications etc. the joints of tiles shall be cleaned off to a depth of 2-3mm and all dust, loose particles shall be removed and joints shall then be flush pointed with white cement added with pigment to match the colour of tiles.

5.3.7 If mentioned specifically elsewhere such as design basis, item description, drawings, job specifications etc. tiles shall be laid with 3mm thick PVC spacers at joints. When the laid tiles have set, the spacers shall be removed and the joints shall be filled and finished with approved quality food grade, stain & chemical resistant coloured epoxy grout matching with the colour of tiles.

5.3.8 The tiled floor shall then be kept wet for 7 days. After curing, the tiled surfaces shall be washed and finished clean

6.0 ACID OR ALKALI RESISTANT TILES

6.1 The Acid or Alkali Resistant tiles shall be of vitreous ware and free from deleterious substances. The iron oxide content allowable in the raw material shall not exceed two percent. The tiles shall be vitrified at the temperature of 1100 deg C and above and shall be kept unglazed. The finished, tile, shall appear fine grained in texture, dense and homogenous. The tiles shall be sound, true to slope, flat and free from flows and manufacturing defects affecting their utility.

The tiles shall conform to IS 4457.

The tiles shall be tested for water absorption, compressive strength, acid resistance as per IS 4457. Sampling procedure for acceptance tests and criteria for conformity shall be as per IS 4457.

The tiles shall be 10mm thick (tolerance: + 2 percent). The depth of the grooves on the underside of the tile shall not exceed 3mm.

The tiles shall be of required colour.

6.2 Workmanship

The finished surface shall not sound hollow when tapped with a wooden mallet.

6.2.1 Base concrete or the RCC slab on which the tiles are to be laid shall be cleaned, wetted and mopped.

6.2.2 The bedding for the tile shall be with acid/alkali resistant cement mortar 1:4 (1acid/alkali resistant cement: 4 coarse sand).

6.2.3 The average thickness of the bedding shall be 10mm for flooring and 12mm for skirting/ Dado while the thickness under any portion of the tiles shall not be less than 10mm.

6.2.4 Mortar shall be spread, tamped and corrected to proper levels and allowed to harden sufficiently to offer a fairly rigid cushion for the tiles to be set and to enable the mason to place wooden plank across and squat on it.

6.2.5 Over this mortar bedding neat grey acid/alkali resistant cement slurry of honey like consistency shall be spread at the rate of 3.3 kg of cement per square metre over an area up to one square metre.

6.2.6 Tiles shall be soaked in water washed clean and shall be fixed in this grout one after another, each tile gently being tapped with a wooden mallet till it is properly bedded and in level with the adjoining tiles. The joints shall be kept as thin as possible and in straight lines or to suit the required pattern.

- 6.2.7 For vertical surfaces, the tiles shall be corrected to proper planes with joints truly vertical in required pattern and butt jointed. The fixing shall be done from bottom upward. The top of skirting and dado shall be truly horizontal.
- 6.2.8 The surface of the flooring during laying shall be frequently checked with a straight edge about 2 m long, so as to obtain a true surface with the required slope.
- 6.2.9 Tiles which are fixed in the floor adjoining the wall shall enter not less than 10mm under the plaster, skirting or dado.
- 6.2.10 After tiles have been laid surplus cement slurry shall be cleaned off. The joints shall be cleaned off the cement slurry with wire/coir brush or trowel to a depth of 2mm to 3mm and all dust and loose mortar removed. Joints shall then be flush pointed with acid/alkali resistant cement added with pigment if required to match the colour of tiles.
- 6.2.11 The tiled floor shall then be kept wet for 7 days. After curing, the tiled surfaces shall be washed and finished clean.

7.0 MARBLE STONE FINISH

7.1 Marble Stone Slabs

The marble slabs shall be of specified size, thickness, type, grade and colour. The marble from which the slabs are made shall be of selected quality, hard, sound, dense, homogenous in texture, free from cracks, decay, weathering and flakes. The sample of marble stone slabs shall be got approved from the Engineer-in-Charge.

Marble stone shall be laid in desired pattern using stones of desired color.

If not mentioned elsewhere i.e. item description, drawings, job specifications etc. marble stone slab shall be second quality Makrana white.

This specification does not cover Marble stone wall cladding and veneering.

Dimensions:

Except for dimensions shown in drawing or cut sizes required to cover the balance areas along peripheries, dimensions of slabs shall be 600mm to 2500mm in length and 600mm to 1000mm in width as per drawing and as directed by Engineer-In-Charge.

Tolerance of + 3% shall be allowed for the thickness. In respect of length and breadth of slabs a tolerance of + 2% shall be allowed.

If not mentioned elsewhere i.e. i.e. item description, drawings, job specifications design basis etc. thickness shall be as below.

1. Thickness of stone slab in flooring and horizontal surfaces: 18mm.
2. Thickness of stone slab in skirting, dado and vertical surfaces: 12mm.

Marble stone in riser, tread of staircases, counter tops shall be of single piece upto 2000mm length. Nosing shall be provided in the treads & counter tops.

Physical properties:

Physical properties of Marble and method of testing shall be as follows:

Physical Property	Requirement	Method of test
Moisture absorption After 24 hours	Maximum 0.4%	IS: 1124

Immersion in cold water		
Hardness	Minimum 3	Mhos scale
Specific Gravity	Minimum 2.5	IS: 1122

7.2 Workmanship

The slabs shall be washed clean before laying. Due care shall be taken to match the grains of slabs which shall be selected judiciously having uniform pattern of veins/ streaks or as directed by the Engineer-In-Charge.

The finished surface shall not sound hollow when tapped with a wooden mallet.

7.2.1 Laying

Laying on floor and horizontal surfaces:

Base slab on which the slabs are to be laid shall be cleaned, wetted and mopped.

Marble slabs shall be laid over average 22mm thick cement mortar 1:4 (1 cement : 4 coarse sand) bedding.

Mortar of the specified mix shall be spread under the area of each slab, roughly to the average thickness specified in the item. The slab shall be washed clean before laying. It shall be laid on top, pressed, tapped with wooden mallet and brought to level with the adjoining slabs. It shall be lifted and laid aside. The top surface of the mortar shall then be corrected by adding fresh mortar at hollows. The mortar shall be allowed to harden a bit and cement slurry of honey like consistency shall be spread over the same at the rate of 4.4 kg of cement per sqm. The edges of the slab already laid shall be buttered with grey or white cement with or without admixture of pigment to match the shade of the marble slabs.

The slab to be laid shall then be lowered gently back in position and tapped with wooden mallet till it is properly bedded in level with and close to the adjoining slabs with as fine a joint as possible.

Subsequent slabs shall be laid in the same manner. After each slab has been laid, surplus cement on the surface of the slabs shall be cleaned off.

Slabs which are fixed in the floor adjoining the wall shall enter not less than 12mm under the plaster skirting or dado. The junction between wall plaster and floor shall be finished neatly and without waviness.

The surface of the flooring as laid shall be true to levels, and, slopes as instructed by the Engineer-in-Charge. Joint thickness shall not be more than 1mm.

Laying on vertical surfaces i.e skirting/ dado/ risers:

The joints shall be raked out to a depth of at least 15mm in masonry walls. In case of concrete surfaces, the surface shall be hacked and roughened with wire brushes. The base surface shall be cleaned thoroughly, washed with water and kept wet before laying is commenced.

In case of skirting, the wall surface shall be cut uniformly to the requisite depth so that the skirting face shall have the projection from the finished face of wall as shown in drawings or as required by the Engineer-in-Charge. In no case the skirting should project by more than thickness of stone.

The slabs shall be held in position by suitable temporary measure such as wooden/ bamboo supports, temporary hook etc. as approved by Engineer-In- Charge. The line of the slab shall be at such a distance from the wall that the average width of the gap shall be 12mm and at no place the width shall be less than 10mm, The outer face of the slabs shall be checked for plane and plumb and corrected. The joints shall be as fine as possible and shall be filled with neat cement paste/ grout with white cement and pigment to match the colour of the slabs. The joints shall thus be left to harden and then the rear gap between the slabs and backing surface shall be packed with average 12mm thick cement mortar 1:3 (1 cement : 3 coarse sand). Temporary supports shall be removed after the mortar filling in the gap has acquired sufficient strength.

The joints shall be as fine as possible but not more than 1mm. The top line of the skirting/ dado/ risers shall be truly horizontal and joints truly vertical.

7.2.2 Curing, Polishing and Finishing

The surface shall be kept wet for a minimum period of 7 days. The day after the slabs are laid, all joints shall be cleaned of the grout with a wire brush or trowel. The surface shall thereafter be grounded evenly using the following carborundum stones.

1st grinding — coarse grade stone (No. 60)

Second grinding — medium grade (No. 80)

Final grinding — fine grade (No. 120)

If desired appearance of the finished surface is not achieved, the surface shall be further polished using requisite carborundum stones (including finer grade) as directed by Engineer-In-Charge.

Visible top surfaces of skirting/ dado etc. and edges of nosing shall be polished.

Water shall be used profusely during grinding. After grinding the surface shall be thoroughly washed to remove all grinding mud, cleaned and mopped.

Each grinding shall be done one day after the previous grinding has been done.

After the final polish, oxalic acid shall be dusted over the surface at the rate of 33 gm per square metre sprinkled with water and rubbed hard with a 'namdah' block (pad of woollen rags).

The following day after the last grinding/ polishing, the surface shall be wiped with a moist rag and dried with a soft cloth and finished clean.

If any stone is disturbed or damaged, it shall be refitted or replaced and properly jointed and polished.

In case of pre-polished stones, any damage or unevenness on the surface shall be rectified.

8.0 KOTA STONE FINISH

8.1 Kota stone slabs

The Kota stone slabs shall be of specified size, thickness, selected quality and shade, hard, sound, dense, homogenous in texture, free from cracks, decay, weathering and flakes. These shall be machine cut to the requisite size and thickness and of the colour indicated in the drawings or as instructed by the Engineer-in-Charge. The sample of stone slabs shall be got approved from the Engineer-in-Charge. Kota stone shall be laid in desired pattern.

The slabs shall have the top (exposed) face polished before being brought to site, unless otherwise specified.

All angles and edges of the slabs shall be true, square and free from chippings and the surface shall be true and plane.

Dimensions:

The slabs shall be machine cut to the requisite dimensions.

Except for dimensions shown in drawing or cut sizes required to cover the balance areas along peripheries, dimensions of slabs shall be 600mm to 2500mm in length and 600mm to 1000mm in width as per drawing and as directed by Engineer-In-Charge.

Tolerance of ± 2 mm shall be allowed for the thickness. In respect of length and breadth of slabs Tolerance of ± 2 mm for machine cut slabs shall be allowed.

If not mentioned elsewhere i.e. item description, drawings, job specifications etc. thickness shall be as below.

1. Thickness of stone slab in flooring and horizontal surfaces: 25mm.
2. Thickness of stone slab in skirting, dado and vertical surfaces: 18mm.

Kota stone in riser, tread of staircases, counter tops shall be of single piece up to 2000mm length. Nosing shall be provided in the treads & counter tops.

8.2 Workmanship

The slabs shall be washed clean before laying.

The finished surface shall not sound hollow when tapped with a wooden mallet.

8.2.1 Laying

Laying on floor and horizontal surfaces:

Base slab on which the slabs are to be laid shall be cleaned, wetted and mopped.

Kota stone slabs shall be laid over average 15mm thick cement mortar 1:4 (1 cement: 4 coarse sand) bedding.

Mortar of the specified mix shall be spread under the area of each slab, roughly to the average thickness specified in the item. The slab shall be washed clean before laying. It shall be laid on top, pressed, tapped with wooden mallet and brought to level with the adjoining slabs. It shall be lifted and laid aside. The top surface of the mortar shall then be corrected by adding fresh mortar at hollows. The mortar shall be allowed to harden a bit and cement slurry of honey like consistency shall be spread over the same at the rate of 4.4 kg of cement per sqm. The edges of the slab already laid shall be buttered with grey or white cement with or without admixture of pigment to match the shade of the marble slabs.

The slab to be plaid shall then be lowered gently back in position and tapped with wooden mallet till it is properly bedded in level with and close to the adjoining slabs with as fine a joint as possible.

Subsequent slabs shall be laid in the same manner. After each slab has been laid, surplus cement on the surface of the slabs shall be cleaned off.

Slabs which are fixed in the floor adjoining the wall shall enter not less than 12mm under the plaster skirting or dado. The junction between wall plaster and floor shall be finished neatly and without waviness.

The surface of the flooring as laid shall be true to levels, and, slopes as instructed by the Engineer-in-Charge.

The edges of the slabs to be jointed shall be buttered with grey cement, with admixture of pigment to match the shade of the slab. The thickness of the joints should be minimum as possible. In any location, it shall not exceed 1mm.

Laying on vertical surfaces i.e skirting/ dado/ risers and vertical surfaces:

The joints shall be raked out to a depth of at least 15mm in masonry walls. In case of concrete surfaces, the surface shall be hacked and roughened with wire brushes. The base surface shall be cleaned thoroughly, washed with water and kept wet before laying is commenced.

In case of skirting, the wall surface shall be cut uniformly to the requisite depth so that the skirting face shall have the projection from the finished face of wall as shown in drawings or as required by the Engineer-in-Charge. In no case the skirting should project by more than thickness of stone.

The slabs shall be held in position by suitable temporary measure such as wooden/ bamboo supports, temporary hook etc. as approved by Engineer-In- Charge. The line of the slab shall be at such a distance from the wall that the average width of the gap shall be 12mm and at no place the width shall be less than 10mm, The outer face of the slabs shall be checked for plane and plumb and corrected. The joints shall be as fine as possible and shall be filled with neat cement paste/ grout with white cement and pigment to match the colour of the slabs. The joints shall thus be left to harden and then the rear gap between the slabs and backing surface shall be packed with average 12mm thick cement mortar 1:3 (1 cement : 3 coarse sand). Temporary supports shall be removed after the mortar filling in the gap has acquired sufficient strength.

The edges of the slabs to be jointed shall be buttered with grey cement, with admixture of pigment to match the shade of the slab. The thickness of the joints should be as minimum as possible. In any location, it shall not exceed 1mm. The top line of the skirting/ dado/ risers shall be truly horizontal and joints truly vertical.

8.2.2 Curing, Polishing and Finishing

The surface shall be kept wet for a minimum period of 7 days. The day after the slabs are laid, all joints shall be cleaned of the grout with a wire brush or trowel. The surface shall thereafter be grounded evenly using the following carborundum stones.

First grinding — medium grade (No. 80)

Final grinding — fine grade (No. 120)

If desired appearance of the finished surface is not achieved, the surface shall be further polished using requisite carborundum stones (including finer grade) as directed by Engineer-In-Charge.

Visible top surfaces of skirting/ dado etc. and edges of nosing shall be polished.



Water shall be used profusely during grinding. After grinding the surface shall be thoroughly washed to remove all grinding mud, cleaned and mopped.

Each grinding shall be done one day after the previous grinding has been done.

After the final polish, oxalic acid shall be dusted over the surface at the rate of 33 gm per square metre sprinkled with water and rubbed hard with a 'namdah' block (pad of woollen rags).

The following day after the last grinding/ polishing, the surface shall be wiped with a moist rag and dried with a soft cloth and finished clean.

If any stone is disturbed or damaged, it shall be refitted or replaced and properly jointed and polished.

In case of pre-polished stones, any damage or unevenness on the surface shall be rectified.

9.0 GRANITE STONE FINISH

The Granite stone shall be of specified size, thickness, type, and colour (such as jet black, cherry red, elite brown, cat eye etc.). They shall be of selected quality, hard, sound, dense, homogenous in texture, free from cracks, decay, weathering and flakes, machine cut and pre-polished/ of flamed finish. The sample of granite stone slabs shall be got approved from the Engineer-in-Charge.

Granite stone shall be laid in desired pattern using stones of desired color.

This specification does not cover Granite stone wall cladding and veneering.

Dimensions:

The slabs shall be machine cut to the requisite dimensions.

Except for dimensions shown in drawing or cut sizes required to cover the balance areas along peripheries, dimensions of slabs shall be 600mm to 2500mm in length and 600mm to 1000mm in width as per drawing and as directed by Engineer-In-Charge.

If not mentioned elsewhere i.e. item description, drawings, job specifications etc 18mm thick Granite slabs shall be provided.

Tolerance of + 1% shall be allowed for the thickness. In respect of length and breadth of slabs a tolerance of + 2% shall be allowed.

Granite stone in riser, tread of staircases, counter tops shall be of single piece upto 2000mm length. Nosing shall be provided in the treads & counter tops.

Finish:

If not mentioned elsewhere i.e item description, drawings, job specifications, design basis etc Granite stone shall be pre-polished finish.

Physical properties:

Physical properties of Granite and method of testing shall be as follows:

Physical Property	Requirement	Method of test
Moisture absorption After 24 hours	Maximum 0.5%	IS: 1124

Immersion in cold water		
Specific Gravity	Minimum 2.6	IS: 1122

9.2 Workmanship

The slabs shall be washed clean before laying.

The finished surface shall not sound hollow when tapped with a wooden mallet.

9.2.1 Laying

Laying on floor and horizontal surfaces:

Base slab on which the slabs are to be laid shall be cleaned, wetted and mopped.

Granite slabs shall be laid over average 22mm thick cement mortar 1:4 (1 cement: 4 coarse sand) bedding.

Mortar of the specified mix shall be spread under the area of each slab, roughly to the average thickness specified in the item. The slab shall be washed clean before laying. It shall be laid on top, pressed, tapped with wooden mallet and brought to level with the adjoining slabs. It shall be lifted and laid aside. The top surface of the mortar shall then be corrected by adding fresh mortar at hollows. The mortar shall be allowed to harden a bit and cement slurry of honey like consistency shall be spread over the same at the rate of 4.4 kg of cement per sqm. The edges of the slab already laid shall be buttered with grey or white cement with or without admixture of pigment to match the shade of the granite slabs.

The slab to be plaid shall then be lowered gently back in position and tapped with wooden mallet till it is properly bedded in level with and close to the adjoining slabs with as fine a joint as possible.

Subsequent slabs shall be laid in the same manner. After each slab has been laid, surplus cement on the surface of the slabs shall be cleaned off.

Slabs which are fixed in the floor adjoining the wall shall enter not less than 12mm under the plaster skirting or dado. The junction between wall plaster and floor shall be finished neatly and without waviness.

The surface of the flooring as laid shall be true to levels, and, slopes as instructed by the Engineer-in-Charge. Joint thickness shall not be more than 1mm.

Laying on vertical surfaces i.e skirting/ dado/ risers:

The joints shall be raked out to a depth of at least 15mm in masonry walls. In case of concrete surfaces, the surface shall be hacked and roughened with wire brushes. The base surface shall be cleaned thoroughly, washed with water and kept wet before laying is commenced.

In case of skirting, the wall surface shall be cut uniformly to the requisite depth so that the skirting face shall have the projection from the finished face of wall as shown in drawings or as required by the Engineer-in-Charge. In no case the skirting should project by more than thickness of stone.

The slabs shall be held in position by suitable temporary measure such as wooden/ bamboo supports, temporary hook etc. as approved by Engineer-In- Charge. The line of the slab shall be at such a distance from the wall that the average width of the gap shall be 12mm and at no place the width shall be less than 10mm, The outer face of the slabs shall be checked for plane

and plumb and corrected. The joints shall be as fine as possible and shall be filled with neat cement paste/ grout with white cement and pigment to match the colour of the slabs. The joints shall thus be left to harden and then the rear gap between the slabs and backing surface shall be packed with average 12mm thick cement mortar 1:3 (1 cement : 3 coarse sand). Temporary supports shall be removed after the mortar filling in the gap has acquired sufficient strength.

The joints shall be as fine as possible but not more than 1mm The top line of the skirting/ dado/ risers shall be truly horizontal and joints truly vertical.

9.2.2 Curing, Polishing and Finishing

The surface shall be kept wet for a minimum period of 7 days. The day after the slabs are laid, all joints shall be cleaned of the grout with a wire brush or trowel. The surface shall be wiped with a moist rag and dried with a soft cloth and finished clean.

If any stone is disturbed or damaged, it shall be refitted or replaced and properly jointed and polished.

Any damage unevenness of the stone surface shall be rectified.

10.0 PVC FINISH

10.1 PVC Roll/ Tiles

PVC roll/ tiles shall be homogenous, of approved texture, colour, pattern, with polyurethane surface protection and shall be of class-1 category for surface spread of flame when tested in accordance with BS 476, part-7.

PVC rolls shall conform to IS: 3462 and PVC tiles shall conform to IS: 3462.

Antistatic PVC roll/ tiles shall conform to B.S.2050, Table-2.

Thickness of PVC roll/ tiles shall be 2mm.

Size of tiles shall be 600mm x 600mm.

If not mentioned elsewhere i.e item description, drawings, job specifications, design basis etc. PVC floor finish shall be with PVC rolls.

PVC roll/ tiles shall be laid in desired pattern in accordance with drawing or as directed by Engineer-In-Charge.

10.2 Workmanship

The base floor on which PVC finish is to be laid shall be prepared in accordance with PVC tile/roll Manufacturer's recommendation.

The base floor shall be made permanently smooth, firm, free of cracks and dry. If required, suitable leveling compound as recommended and approved by PVC tile/roll manufacturer shall be applied over the base floor.

PVC rolls/tiles shall be brought to the temperature of the area in which it is to be laid and stacked suitably near the site in accordance with manufacturer's recommendation.

Laying of PVC roll/ tile shall be in accordance with manufacturer's recommendation using adhesive (Fevicol SR-505 or other adhesive as recommended by Manufacturer and approved by Engineer-In-Charge).

In case of rolls, minimum possible number of joints shall be provided.

PVC rolls shall be placed in position from one end onwards slowly without creation on any air pockets between roll and the base floor.

PVC rolls/tiles shall be placed only when the adhesive is set sufficiently for laying. After placing, the rolls/tiles shall be pressed suitably with a wooden roller weighing about 5 kg. The joint between adjacent rolls shall be thin hairline type.

PVC rolls in flooring shall be continued for skirting without any joints.

Joints, seams of the PVC flooring shall be sealed by thermo-welding the joints using PVC welding bar of matching colour.

Any excess adhesive squeezing out of the surface shall be wiped off immediately with a wet cloth. In case of such excess adhesive becoming hard, it shall be removed using suitable removing product.

After a minimum period of 24 hours after laying the rolls/tiles, the finished floor shall be cleaned with a wet cloth soaked in warm soap or detergent solution as per approved manufacturer's specifications.

11.0 ABRASION RESISTANT EPOXY FLOOR COATING SYSTEM

Abrasion resistant epoxy floor coating system shall consist of primer coat, levelling/ self smoothing screed and a top finishing coat. All components of the system shall be compatible to its under and top layer/coat and shall be of single Manufacturer.

11.1 Material

Primer, screed and top coat shall meet the requirements of the table below :

Requirement	Primer	Screed	Top Coat
Material	Solvent free Epoxy resin.	Shall comprise of resin base, resin hardener and fillers and shall be self-smoothing.	Shall comprise of resin base, resin hardener and aggregate/ fillers , shall be self-smoothing and of approved colour.
Dry film Thickness (Minimum)	200 micron	2000 micron	2000 micron
Material coverage	Material shall be applied in quantity worked out considering minimum coverage mentioned in the data sheet (authenticated by the Manufacturer) for intended surface area for specified thickness.		
Tensile strength (Minimum Value) Material shall meet minimum value corresponding to any test method mentioned below.			
ASTM D 638	-	08 MPa at 7 days	51Mpa at 7 days

ASTM C 307	-	-	25 MPa at 7 days
EN ISO 527	-	-	07 MPa at 7 days
BS 6319 Part-7	-	08 MPa at 7 days	10 MPa at 7 days
Compressive strength (Minimum Value) Material shall meet minimum value corresponding to any test method mentioned below.			
ASTM D695	-	40 MPa at 7 days	50 MPa at 7 days
ASTM C 579	-	-	40 MPa at 7 days
EN ISO 604	-	-	50 MPa at 7 days
BS 6319 Part-2	-	50 MPa at 7 days	50 MPa at 7 days
Abrasion resistance (Minimum Value)			
ASTM D 4060	-	-	45 Mg thickness loss/ 1000 cycle of CS 17 wheel
Shore D Hardness (Minimum Value)			
ASTM D 2240	-	75	75
Bond strength to concrete (Minimum Value) Material shall meet minimum value corresponding to any test method mentioned below.			
ASTM D 4541	1.5 MPa concrete failure	-	-
ASTMD 412	1.0 MPa concrete failure	-	-

11.2 Workmanship

The work shall be carried out by Applicator recommended by coating Manufacturer and approved by Engineer-In-Charge.

Waiting time between the coats i.e. primer, screed and top coat should be as recommended by Manufacturer.

Surface preparation:

Base concrete slab shall be grinded thoroughly (minimum upto 150-200 microns) to make the surface suitable for epoxy application and achieve desired surface profile.

Base concrete slab on which epoxy coating is to applied shall be cleaned and made free from oil, grease, foreign particles, dust, dirt, debris, loose epoxy coatings, paint, sealers etc. by using wire brushes or mechanical means.

Cutting of construction & control joints in concrete floor including Isolation joints in perimeter of column, Door & floor joint, Machine foundation should be done within 48 to 72 hours after the concrete floor is laid.

These joints in the concrete floor shall be filled with Poly-Urathane sealant (Having Shore A hardness more than 60 and Movement Accommodation Factor (MAF) more than 10%).

Any damage or pot holes in the concrete floor shall be rectified as directed by Engineer-In-Charge.

Primer coat:

Primer coat shall be applied when the prepared surface is ready for such application.

Primer coat as per specification shall be applied by brush and in accordance with recommendations by the coating manufacturer to specified thickness and using specified coverage.

The primer will be left for minimum seven hours or as recommended by manufacturer. to dry before the application of screed.

Screed:

Screed as per specification shall be applied over the primed surface using steel trowel, mixing the ingredients in right proportion and in accordance with recommendations by the coating manufacturer to specified thickness and using specified coverage.

Spike Rollers shall be used to remove air entrapment in the screed.

The screed shall be left to get air cured for minimum time as recommended by manufacturer so as to get the floor dry and hard to take care of walking movement. Further it will be cleaned and inspected for pin holes which shall be patched up suitably.

Top coat:

Top coat as per specification and of approved colour shall be applied over the screed using steel trowel, mixing the ingredients in right proportion and in accordance with recommendations by the coating manufacturer to specified thickness and using specified coverage.

Spike Rollers shall be used to remove air entrapment.

Any damage or incorrect work/finish shall be suitably rectified.

The finished surface shall be left to dry and cure for minimum 24 hours (for human movement), 72 hours (for light weight movement), 7 days (for heavy movement) or as recommended by manufacturer.

11.3 Submittals by Contractor

Contractor shall submit following:

1. Product Data Sheet authenticated (signed and stamped) by the Manufacturer.
2. Test certificates in support of specified properties/ values.

12.0 ABRASION & IMPACT RESISTANT POLYURETHANE CONCRETE FLOOR COATING SYSTEM

Abrasion & impact resistant Polyurethane (PU) concrete floor coating system shall consist of primer coat, screed or scratch-coat and a top finishing coat. All components of the system shall be compatible to it's under and top layer/coat and shall be of single Manufacturer.

12.1 Material

Primer, screed or scratchcoat and top coat shall meet the requirements of the table below :

Requirement	Primer	Screed or scratch-coat	Top Coat
Material	Waterborne Epoxy resin or other material compatible to other coats of the system.	Shall comprise of Polyurethane Resin base, resin hardener and fillers	Shall comprise of resin base, resin hardener and aggregate/ fillers , shall be self-smoothing, fast setting and of approved colour
Dry Film Thickness (Minimum)	50 micron	1000 micron	3000 micron
Material coverage	Material shall be applied in quantity worked out considering minimum coverage mentioned in the data sheet (authenticated by the Manufacturer) for intended surface area for specified thickness.		
Tensile strength (Minimum Value)			
Material shall meet minimum value corresponding to of any test method mentioned below.			
ASTM D 638	-	05 MPa at 28 days	05 MPa at 28 days
ASTM C 307	-	06 MPa at 28 days	06 MPa at 28 days
EN ISO R527	-	09 MPa at 28 days	09 MPa at 28 days
BS 6319 Part-7	-	06 MPa at 28 days	06 MPa at 28 days
Compressive strength (Minimum Value)			
Material shall meet minimum value corresponding to of any test method mentioned below.			
ASTM D695	-	40 MPa at 28 days	40 MPa at 28 days
ASTM C 579	-	40 MPa at 28 days	40 MPa at 28 days
BS 6319 Part-2	-	45 MPa at 28 days	45 MPa at 28 days
Abrasion resistance (Minimum Value)			
ASTM D 4060	-	-	50Mg thickness loss/ 1000 cycle of CS 17 wheel
Bond strength to concrete (minimum value)			
Material shall meet minimum value corresponding to of any test method mentioned below.			
ASTM D 4541	1.5 MPa concrete failure	-	-
ASTMD 412	1.0 MPa concrete	-	-

	failure		
Impact Resistance (minimum Value)			
ASTM D 2794	-	-	8 Joules for 3mm thickness

12.2 Workmanship

The work shall be carried out by Applicator recommended by coating Manufacturer and approved by Engineer-In-Charge.

Waiting time between the coats i.e. primer, screed and top coat shall be as recommended by Manufacturer.

Surface preparation:

Base concrete slab shall be grinded thoroughly (minimum upto 150-200 microns) to make the surface suitable for epoxy application and achieve desired surface profile.

Base concrete slab on which PU coating is to applied shall be cleaned and made free from oil, grease, foreign particles, dust, dirt, debris, loose epoxy coatings, paint, sealers etc. by using wire brushes or mechanical means.

Cutting of construction & control joints in concrete floor including Isolation joints in perimeter of column, Door & floor joint, Machine foundation should be done within 48 to 72 hours after the concrete floor is laid.

These joints in the concrete floor shall be filled with Poly-Urethane sealant (Having Shore A hardness more than 60 and Movement Accommodation Factor (MAF) more than 10%).

Any damage or pot holes in the concrete floor shall be rectified as directed by Engineer-In-Charge.

Primer coat :

Primer coat shall be applied when the prepared surface is ready for such application.

Primer coat as per specification shall be applied by brush and in accordance with recommendations by the coating manufacturer to specified thickness and using specified coverage.

The primer will be left for minimum seven hours or as recommended by manufacturer to dry before the application of screed.

Screed or Scratch coat:

Screed or Scratch-coat shall be applied over the primed surface using notched trowel, mixing the ingredients in right proportion and in accordance with recommendations by the coating manufacturer to specified thickness and using specified coverage.

Spike Rollers shall be used to remove air entrapment in the screed.

The screed shall be left to get air cured for 3-4 hours or as recommended by the Manufacturer to get the floor dry and hard to take care of walking movement. Further it will be cleaned and inspected for pin holes which shall be patched up suitably.

Top coat:

Top coat as per specification and of approved colour shall be applied over the screed or scratch coat using notched trowel, mixing the ingredients in right proportion and in accordance with recommendations by the coating manufacturer to specified thickness and using specified coverage.

Spike Rollers shall be used to remove air entrapment.

Any damage or incorrect work/finish shall be suitably rectified.

The finished surface shall be left to dry and cure for minimum 24 hours (for human movement), 72 hours (for light weight movement), 7 days (for heavy movement) or as recommended by the Manufacturer.

12.3 Submittals by Contractor

Contractor shall submit following:

1. Product Data Sheet authenticated (signed and stamped) by the Manufacturer.
2. Test certificates in support of specified properties/ values.

13.0 CHEMICAL RESISTANT NOVOLAC EPOXY FLOOR COATING SYSTEM

Chemical resistant Novolac Epoxy floor coating system shall consist of primer coat, levelling screed or scratch coat and chemical resistant top coat. All components of the system shall be compatible to it's under and top layer/coat and shall be of single Manufacturer.

13.1 Material

Primer, screed or scratch coat, coloured coat and final clear coat shall meet the requirements of the table below:

Note:

For chemical resistant top coat, any option (option 1 and option 2) mentioned in the table is acceptable.

Requirement	Primer	Screed or scratch coat	Top coat	
			Option1 – Top coloured coat over clear chemical resistance coat	Option 2 – Coloured chemical Resistance coat

Material	Solvent free Epoxy resin	Shall comprise of resin base, resin hardener and fillers and shall be self-smoothing	Top coloured coat shall comprise of resin base, resin hardener and aggregate/ fillers , shall be self-smoothing and of approved colour Clear chemical resistance coat shall comprise of resin, hardener and shall be self smoothing and shall be solvent free.	Shall comprise of resin, hardener and shall be self smoothing and shall be solvent free and of approved colour.
Dry Film Thickness (Minimum)	200 micron	2000 micron	Total 1000 micron (500 micron for both clear and coloured coat)	500 micron
Material coverage	Material shall be applied in quantity worked out considering minimum coverage mentioned in the data sheet (authenticated by the Manufacturer) for intended surface area for specified thickness.			
Tensile strength (Minimum Value)				
Material shall meet minimum value corresponding to of any test method mentioned below.				
ASTM D 638	-	08 MPa at 7 days	14 MPa at 7 days	14 MPa at 7 days
ASTM C 307	-	-	-	-
EN ISO 527	-	-	-	-
BS 6319 Part-7	-	08 MPa at 7 days	-	-
Compressive strength (Minimum Value)				
Material shall meet minimum value corresponding to of any test method mentioned below.				
ASTM D 695	-	40 MPa at 7 days	60 MPa at 28 days/	-
ASTM C 579	-	-	85 Mpa at 28 days	-
EN ISO 604	-	-	-	-
BS 6319 Part-2	-	50 MPa at 7 days	-	-

Abrasion resistance				
ASTM D 4060	-	45 Mg thickness loss/ 1000 cycle of CS 17 wheel	-	60 Mg thickness loss/ 1000 cycle of CS 17 wheel
ASTM D 4060	-	-	-	<0.10 Mg/ cycle of 1 Kg CS10 wheel
Shore D Hardness				
ASTM D 2240	-	70	70	70
Bond strength to concrete				
Material shall meet minimum value corresponding to any test method mentioned below.				
ASTM D 4541	1.5 MPa Concrete failure	-	-	-
ASTMD 412	1.0 MPa concrete failure	-	-	-

13.2 Workmanship

The work shall be carried out by Applicator recommended by coating Manufacturer and approved by Engineer-In-Charge.

Waiting time between the coats i.e. primer, screed or scratch coat, top coloured coat and top clear coat shall as recommended by Manufacturer.

Surface preparation:

Base concrete slab shall be grinded thoroughly (minimum upto 150-200 microns) to make the surface suitable for epoxy application and achieve desired surface profile.

Base concrete slab on which epoxy coating is to applied shall be cleaned and made free from oil, grease, foreign particles, dust, dirt, debris, loose epoxy coatings, paint, sealers etc. by using wire brushes or mechanical means.

Cutting of construction & control joints in concrete floor including Isolation joints in perimeter of column, Door & floor joint, Machine foundation should be done within 48 to 72 hours after the concrete floor is laid.

These joints in the concrete floor shall be filled with Poly-Urathane sealant (Having Shore A hardness more than 60 and Movement Accommodation Factor (MAF) more than 10%).

Any damage or pot holes in the concrete floor shall be rectified as directed by Engineer-In-Charge.

Primer coat:

Primer coat shall be applied when the prepared surface is ready for such application.

Primer coat as per specification shall be applied by brush and in accordance with recommendations by the coating manufacturer to specified thickness and using specified coverage.

The primer will be left for minimum seven hours or as recommended by manufacturer. to dry before the application of screed.

Screed:

Screed as per specification shall be applied over the primed surface using steel trowel, mixing the ingredients in right proportion and in accordance with recommendations by the coating manufacturer to specified thickness and using specified coverage.

Spike Rollers shall be used to remove air entrapment in the screed.

The screed shall be left to get air cured for 7 hours or as recommended by the Manufacturer to get the floor dry and hard to take care of walking movement. Further it will be cleaned and inspected for pin holes which shall be patched up suitably.

Top coat:

Top coat as per specification and of approved colour shall be applied over the screed using steel trowel, mixing the ingredients in right proportion and in accordance with recommendations by the coating manufacturer to specified thickness and using specified coverage.

Chemical resistance top coat should be immediately applied to the prepared surface ensuring a continuous coating of uniform thickness. Stiff nylon brush or short nap roller is recommended for such application.

Chemical resistant, clear coating (option-1) shall be applied over cured top coloured coat using roller, mixing the ingredients in right proportion and in accordance with recommendations by the coating manufacturer to specified thickness and using specified coverage.

Spike Rollers shall be used to remove air entrapment.

Any damage or incorrect work/finish shall be suitably rectified.

The finished surface shall be left to dry and cure for minimum 24 hours (for human movement), 72 hours (for light weight movement), 7 days (for heavy movement) or as recommended by the Manufacturer.

13.3 Submittals by Contractor

Contractor shall submit following:

1. Product Data Sheet authenticated (signed and stamped) by the Manufacturer.
2. Test certificates in support of specified properties/ values.

14.0 CHEMICAL RESISTANT NOVOLAC EPOXY WALL COATING SYSTEM

Chemical resistant Novolac epoxy wall coating system shall consist of primer coat and a top coloured coat All components of the system shall be compatible to it's under and top layer/coat and shall be of single Manufacturer.

14.1 Material

Primer and top coat shall meet the requirements of the table below :

Note :

For chemical resistant top coat, any option (option 1 and option 2) mentioned in the table is acceptable.

Requirement	Primer	Top coat	
		Option 1- Top coloured coat over chemical resistant clear coat	Option 2- Chemical Resistance coloured top coat
Material	Solvent free Epoxy resin	Chemical resistant clear coat shall comprise of resin, hardener and shall be self smoothing. Coloured coat shall comprise of resin base, resin hardener and shall be of approved colour	Shall comprise of resin, hardener and shall be self smoothing of approved colour.
Dry film Thickness (Minimum)	200 micron	Chemical resistant clear coat : 300 micron Coloured coat: 100 micron	400 micron
Material coverage	Material shall be applied in quantity worked out considering minimum coverage mentioned in the data sheet (authenticated by the Manufacturer) for intended surface area for specified thickness.		
Tensile strength (Minimum Value)			
Material shall meet minimum value corresponding to of any test method mentioned below.			
ASTM D 638	-	10 Mpa at 7 days	30 MPa at 7 days

14.2 Workmanship

The work shall be carried out by Applicator recommended by coating Manufacturer and approved by Engineer-In-Charge.

Waiting time between the coats i.e. primer, screed and top coat shall be as recommended by Manufacturer.

Surface preparation:

Base wall shall be grinded lightly or rubbed with a sand paper thoroughly to make the surface suitable for application and achieve desired surface profile.

Base on which coating is to applied shall be cleaned and made free from oil, grease, foreign particles, dust, dirt, debris, loose epoxy coatings, paint, sealers etc. using wire- brushes or mechanical means.

Putty may be applied to the base wall surface depending upon the existing condition of the surface and as directed by Engineer-In-Charge

Any damage or holes or cracks in the wall shall be rectified as directed by Engineer-In-Charge.

Primer coat:

Primer coat shall be applied when the prepared surface is ready for such application.

Primer coat as per specification shall be applied by brush and in accordance with recommendations by the coating manufacturer to specified thickness and using specified coverage.

The primer will be left for minimum seven hours or as recommended by manufacturer to dry before the application of screed.

Top coat:

Top coat as per specification and of approved colour shall be applied over the screed using steel trowel, mixing the ingredients in right proportion and in accordance with recommendations by the coating manufacturer to specified thickness and using specified coverage.

Chemical resistance top coat should be immediately applied to the prepared surface ensuring a continuous coating of uniform thickness. Stiff nylon brush or short nap roller is recommended for such application.

Chemical resistant, clear coating (option-1) shall be applied over cured top coloured coat using roller, mixing the ingredients in right proportion and in accordance with recommendations by the coating manufacturer to specified thickness and using specified coverage.

Spike Rollers shall be used to remove air entrapment.

Any damage or incorrect work/finish shall be suitably rectified.

14.3 Submittals by Contractor

Contractor shall submit following:

1. Product Data Sheet authenticated (signed and stamped) by the Manufacturer.
2. Test certificates in support of specified properties/ values.

15.0 MEASUREMENTS

For measurement of floor finishing, skirting, wall finishing etc. mentioned in this specification, actual finished surface shall be measured.

No deduction shall be done for cutting or wastage of materials.

स्टील/अलुमिनियम दरवाजे, खिडकियों
एवं रोशनदान का मानक विनिर्देशन

**STANDARD SPECIFICATION
FOR STEEL/ALUMINIUM DOORS,
WINDOWS AND VENTILATORS**

8	19.10..23	REVISED & ISSUED AS STANDARD SPECIFICATION	<i>PDe</i> PIYALEE DAS	<i>Atul</i> ATUL GUPTA	<i>W.D.</i> SAMIR DAS	<i>J.K.</i> SANJAY MAZUMDAR
7	04.06.18	REVISED & ISSUED AS STANDARD SPECIFICATION	AG	SD	RS	R.K.TRIVEDI
6	03.03.14	REVISED & ISSUED AS STANDARD SPECIFICATION	AG	SD	JKB	S.CHATURVEDI S.CHANDA
5	03.03.11	REVISED & ISSUED AS STANDARD SPECIFICATION	GJK	SD	JKB	VK D. MALHOTRA
Rev. No	Date	Purpose	Prepared by	Checked by	Standards Committee Convenor	Standards Bureau Chairman
						Approved by