

- a. Complaints
- b. Compliances on safety defects / shortfalls
- c. Suggestions
- d. Proposals for changes & improvements
- e. HSE Reports (including near-miss reports)

### 3.3.21 Confined Space Entry

The contractor shall generate a work permit (Format No. HSE -7) before entering a confined space. People, who are permitted to enter into confined space, must be medically examined & certified by registered doctor, confirming their 'medical fitness for working in confined space'. All necessary precautions mentioned therein shall be adhered to. An attendant shall be positioned outside a confined space for extending help during an emergency. Effective communication shall be maintained between personnel in confined space and outside by combination of visual/voice or portable radio. Compressed gas cylinders shall not be taken into confined space. Entry Register for confined space to be maintained with the name and time of entry/exit. All appropriate PPEs and air quality parameters shall be checked before entering a confined space. It shall be ensured that the piping of the equipment which has to be opened is pressure-free by checking that blinds are in place, vents are open and volume is drained. Inside confined space works, only electrical facilities / installations of 24V shall be permitted. Contractor shall ensure usage of safe & suitable arrangement of oxygen supply for individual workmen (during the course of work in confined space), if oxygen concentration is found to be less than 19.5% (v/v) there. All persons must be made aware of the risk associated with Nitrogen & all precautionary measures shall be taken when vessel/sphere/pipelines etc. are being purged with nitrogen.

Rescue arrangement must be readily available at workplace to fulfill requirement of the emergency situation.

### 3.3.22 Heavy Lifts

- a) The contractor shall submit detailed rigging study/ plan for EIL/ Owner approval prior to lifting equipment requiring a crane of approx. 100 MT capacity or more due to constraints of its dimensions, location of foundation height, approach & weight.
- b) Contractor shall generate the format no. HSE-15 "Permit for heavy lift/critical erection"
- c) The Safe Working Load (SWL) and manufacturer's serial numbers shall be clearly marked on the slings and the lifting gears, either by tagging, stamping, engraving or embossing.
- d) Prior to actual lifting activities, contractor shall check the validity of the crane inspection certificate issued by statutory/ competent authority. This requirement shall also apply to all rigging equipment's utilized for the job.
- e) The contractor shall, at all times, be responsible for all rigging activities.
- f) The Contractor shall ensure medical fitness of all workmen who are engaged / involved in erection of equipment's, vessels etc. and such fitness checks shall be carried-out every six months interval with the help of a registered medical practitioner & record shall be maintained
- g) Adequate safety measures such as positive barricading, usage of appropriate PPEs, permit to work, etc. shall be taken during all heavy or critical lifts.
- h) Ground condition should be suitable to sustain the Ground Bearing Load of the Crane with full load condition.
- i) For lifting any material (irrespective of shape, size or volume), at any height, it is always advisable to prepare a Plan of Erection (PoE) taking into consideration hazards & risks associated therein – this can enable people to put their own experiences of various natures & side-by-side establish a practical method for risk-free erection / lifts. The contractor shall

prepare PoE & shall document the same, when risks are identified as “medium” or “high” and the same shall be approved by its competent / qualified engineer.

### 3.3.23 Key Performance Indicators

The contractor shall measure an activity in both leading & trailing indicators for statistical and performance measurement. The activities pertaining to key performance indicators are covered in Monthly HSE Report (Format No. HSE-5). The contractor shall try to achieve a statistically fair record and strive for its continual improvement.

Leading Indicators viz:-:

- Number of Safety Inductions carried-out at site (for workmen & staff members)
- Number of HSE inspections carried out
- Number of “Safety Walk Through” carried-out by site-head.
- Number of HSE shortfalls / lapses identified per contractor & closed-out in time.
- Number of Safety Meetings conducted (in-house / with contractors)
- Number of HSE Audits made (internal & external) vis-à-vis non conformances raised
- Number of HSE Awareness / Motivational program conducted by contractors
- Number of HSE Trainings conducted at site for supervisors & workmen
- Study of Near miss case reported
- Encouragements / Awards / Recognitions to workmen, job supervisors & field engineers.
- Suggestions for improvement

Trailing Indicators viz:-:

- Calculation of HSE statistics viz frequency rate, severity rate, LTA free man hours etc.
- Analysis of incidents / accidents (nature, severity, types etc.)
- Study of Incident / Accident with respect to :-
  - Variety
  - Period of the year / project span
  - Timings of the incident / accident
  - Age profile of victims
  - Body parts involved
  - Penalty levied for causing incident / accident

### 3.3.24 Unsuitable Land Conditions

Contractor shall take appropriate measures and necessary work permits/clearances if work is to be done in or around marshy areas, river crossings, mountains, monuments, etc. The Contractor shall make right assessment and take all necessary action for developing work areas to make them safe & suitable for crane operations or other vehicular movement before carrying out any project related activity / operation. Contractor shall take all necessary actions to make the surroundings of its site establishments (site office, stores, lay-down area etc.) work-worthy safe and secure.

### 3.3.25 Under Water Inspection

Contractor shall ensure that boats and other means used for transportation, surveying & investigation works shall be certified seaworthy by a recognized classification society. It shall be equipped with all life saving devices like life jackets, adequate fire protection arrangement and shall possess communication facilities like cellular phones, wireless, walkie-talkie. All divers used for seabed surveys, underwater inspections shall have required authorized license, suitable life-saving kit. Number of hours of work by divers shall be limited as per regulations. EIL/ Owner shall have the right to inspect the boat and scrutinize documents in this regard.

### 3.3.26 Excavation

The Contractor shall obtain permission from competent authorities prior to excavation wherever required.

The Contractor shall locate the position of buried utilities (water line, cable route, etc.) by referring to project / plant drawing / in consultation with EIL/Owner. The Contractor shall start digging manually to locate the exact position of buried utilities & thereafter use mechanical means.

In case of non-availability of sufficient data/drawings, underground services i.e. underground cable/ pipe shall be checked by cable detector/pipe locator by the contractor.

The Contractor shall keep soil heaps at least 1.5 M away from edge or a distance equal to depth of pit (whichever is more)

All excavated pits greater than 10 Sq.M plan area and depth more than 1.5M shall have at least two access routes for ingress and egress. Also, additional access routes shall be provided such that distance between any two access routes shall not be more than 20M.

The Contractor shall maintain sufficient "angle of repose" during excavation – shall also provide slope or suitable bench as decided by EIL / Owner.

The Contractor shall arrange "battering" or "benching" wherever required for preventing collapse of edge of excavations.

Avoid vertical wall of less than 2mtrs between two adjacent deep excavated pit/area. Further deep excavation should not be kept open for a longer duration.

The Contractor shall identify & arrange de-watering pump or well-point system to prevent earth collapse due to heavy rain / influx of underground water.

The Contractor shall arrange protective fencing/hard barricading with warning signal around excavated pits, trenches, etc. along with minimum 2 (two) entries, exits / escape ladders.

The Contractor must avoid "underpinning" / under-cutting to prevent collapse of chunk of earth during excavation.

The Contractor shall use "stoppers" to prevent over-run of vehicle wheels at the edge of excavated pits / trenches. Vehicles movement should be restricted to minimum three meters away from the excavated pit.

The Contractor shall arrange strengthening of "shoring" & "strutting" proactively to avoid collapse of earth / edges due to vehicular movement in close proximity of excavated areas / pits/ trenches, etc.

### 3.4 Tool Box Talks (TBT)

Contractor shall conduct daily TBT with workers prior to start of work and shall maintain proper record of the meeting. A suggested format is given below. The Job specific TBT is to be conducted by the immediate supervisor of the workers.

The Contractor shall conduct TBT before start of every morning or evening shift or night shift activities, for alerting the workers on specific hazards and their appropriate dos & don'ts. The Contractor shall provide sufficient rests to the site workmen and their foremen to avert fatigue & thereby endangering their lives during the course of site works.

TOOLBOX TALK RECORDING SHEET

Date & Time		
Work Location		
Subject (Nature of work)		
Presenter		
Hazards involved		
Precautions to be taken		
Worker's Name	Signature	Section
Remarks, in any		

The topics during TBT shall include

- Hazards related to work assigned on that day and precautions to be taken.
- Any forthcoming HSE hazards/events/instruction/orders, etc.

The above record can be kept in local language, which workers can read. These records shall be made available to EIL/ Owner whenever demanded.

### 3.5 Training & Induction Programme

- a) Initial induction of workers into Construction oriented activities and appraising them about the methodology of works and how to carry-out safely and the same should not be inter mixed with Tool Box Talks or HSE Training. In this regard careful action should be made& maintained for imparting HSE induction to every individual, irrespective of his task/designation/level of employment, whereas, HSE Training should be imparted to specific person/group of people who are to carry-out that specific task more than once – for example, Riggers must be trained for working at heights, welders must be trained for work in confined space, fitters/carpenters, mesons must be trained for work at heights, etc. Contractor shall arrange suitable facilities (e.g training room/place, audio visual facilities etc.) for organizing such training on HSE.
- b) Contractor shall conduct Safety induction programme on HSE for all his workers and maintain records. Sticker for “Safety Induction” shall be pasted on the safety helmet of the site personnel. The Gate Pass shall be issued only to those workers who successfully qualify the Safety induction programme. Contractor to conduct effective safety induction program at work site by making efforts to arrange Video film/Virtual Reality (VR) technology pertaining to the escape routes, assembly points, risks involved in the event of an emergency etc while imparting safety induction.
- c) The Contractor brief the visitors about the HSE precautions which are required to be taken before their proceeding to site and make necessary arrangements to issue appropriate PPEs like Aprons, hard hats, ear-plugs, goggles & safety shoes etc., to his visitors. The Contractor shall always maintain relevant acknowledgement from visitor on providing him brief information on HSE actions.
- d) Contractor shall submit job specific training schedule for approval of EIL/Owner &ensure that all his personnel possess appropriate training to carry out the assigned job safely. The training should be imparted in a language understood by them and should specifically be trained about
  - Potential hazards to which they may be exposed at their workplace

- Measures available for prevention and elimination of these hazards

The topics during training shall cover, at the minimum: -

- Why safety should be considered during work - explanation
  - Education about hazards and precautions required
  - Employees' duties & responsibilities
  - Emergency and evacuation plan
  - HSE requirements during project activities
  - Fire fighting and First-Aid
  - Use of PPEs
  - Occupational health issues – dos & don'ts
  - Local laws on intoxicating drinks, drugs, smoking in force
  - Common environmental subjects – lighting, ventilation, vibration, smoke/fumes etc.
- e) Records of the training shall be kept and submitted to EIL/ Owner.
- f) The Contractor shall make regular program for conducting Safety Training on various topics related to various activities & their safe-guarding utilizing experienced persons / outside agency / faculty. A program for Safety Training (indicative list as per Appendix –F) shall be furnished by the Contractor in its HSE Plan.
- g) For offshore and jetty jobs, contractor shall ensure that all personnel deployed have undergone a structured sea survival training including use of lifeboats, basket landing, use of radio communication etc. from an agency acceptable to Owner/EIL.

### 3.6 ADDITIONAL SAFETY REQUIREMENTS FOR WORKING INSIDE A RUNNING PLANT

As a minimum, the contractor shall ensure adherence to following safety requirements while working in or in the close vicinity of an operating plant:

- a) Contractor shall obtain permits for Hot work, Cold work, Excavation and Confined Space from Owner in the prescribed format.
- b) The contractor shall monitor record and compile list of his workers entering the operational plant/unit each day and ensure & record their return after completing the job.
- c) Contractor's workers and staff members shall use designated entrances and proceed by designated routes to work areas only assigned to them. The workers shall not be allowed to enter units' area, tanks area, pump rooms, etc. without work authorization permit.
- d) Work activities shall be planned in such a way so as to minimize the disruption of other activities being carried out in an operational plant/unit and activities of other contractors.
- e) The contractor shall submit a list of all chemicals/toxic substances that are intended to be used at site and shall take prior approval of the Owner.
- f) Specific training on working in a hydrocarbon plant shall be imparted to the work force and mock drills shall be carried out for Rescue operations/First-Aid measures.
- g) Proper barricading/cordoning of the operational units/plants shall be done before starting the construction activities. No unauthorized person shall be allowed to trespass. The height and overall design of the barricading structure shall be finalized in consultation with the Owner and shall be got approved from the Owner.
- h) Care shall be taken to prevent hitting underground facilities such as electrical cables, hydrocarbon piping during execution of work.

- i) Barricading with water curtain shall be arranged in specific/critical areas where hydrocarbon vapors are likely to be present such as near horton spheres or tanks. Positioning of fire tenders (from owner) shall also be ensured during execution of critical activities.
- j) Emergency evacuation plan shall be worked out and all workmen shall be apprised about evacuation routes. Mock drill operations may also be conducted.
- k) Flammable gas test shall be conducted prior to any hot work using appropriate measuring instruments. Sewers, drains, vents or any other gas escaping points shall be covered with flame retardant tarpaulin.
- l) Respiratory devices shall be kept handy while working in confined zones where there is a danger of inhalation of poisonous gases. Constant monitoring of presence of Gas/Hydrocarbon shall be done.
- m) Clearance shall be obtained from all parties before starting hot tapping, patchwork on live lines and work on corroded tank roof.
- n) Positive isolation of line/equipment by blinding for welding/cutting/grinding shall be done. Closing of valve will not be considered sufficient for isolation.
- o) Welding spatters shall be contained properly by using fire retardant blanket and in no case shall be allowed to fall on the ground containing oil. Similar care shall be taken during cutting operations. Fire watcher to be deployed to ensure the same.
- p) The vehicles, cranes, engines, etc. shall be fitted with spark arresters on the exhaust pipe and got it approved from Safety Department of the Owner.
- q) Plant air should not be used to clean any part of the body or clothing or use to blow off dirt on the floor.
- r) Gas detectors should be installed in gas leakage prone areas as per requirement of Owner's plant operation personnel.
- s) Flame proof electrical distribution board, plug and socket shall be used for electrical appliances.
- t) Experienced full time safety personnel shall be exclusively deployed to monitor safety aspects in running plants.

### 3.7 Self-Assessment and Enhancement

The contractor shall develop a method of check & balance through self-assessment & enhancement techniques and shall explore the opportunities for continual improvement in the HSE system.

### 3.8 HSE Promotion

The contractor shall encourage his workforce to promote HSE efforts at workplace by way of organizing workshops/seminars/training programs, celebrating HSE awareness weeks & National Safety Day, conducting quizzes & essay competitions, distributing pamphlets, posters & material on HSE, providing incentives for maintaining good HSE practices and granting incentives/ bonus for completing the job without any lost time accident.

### 3.9 Lock Out and Tag Out (LOTO) for Isolation of Energy Source

- a) Contractor shall follow the LOTO/Isolation procedure of owner for all energy source isolations installed/under purview by /of owner i.e. "Brown field"
- b) For all the other energy source (not under purview of client/owner) i.e. "Green field" Contractor shall develop a system to ensure the isolation of equipments, pipelines, Vessel, electrical panels from the energy source covering following as minimum:-

- Identification of all energy source viz electrical, mechanical, hydraulic, pneumatic, chemical, thermal, gravitational, radiation and other forms of stored or kinetic energy.
  - Establishing the energy isolation devices viz manually operated electrical circuit breakers, disconnection switches, blind flanges, etc.
  - Installation of Lock Out devices for preventing the inadvertent release of stored energy and Tag Out devices (“Danger”, “Do Not operate” or Do not Remove”tags) to indicate that testing, maintenance or servicing is underway and the device cannot be operated until the tag out device is removed.
  - Lock Out and Tag out log book
  - Permit for isolation and de-isolation of energy source as per format No.: HSE-16
  - Availability of competent persons like experienced operators at substations, pump house, units etc. supervisors etc.
- c) Contractor shall ensure that all the sources are locked out and tagged properly before giving clearance to start the job.
- d) After the completion of job, contractor shall ensure all tools and tackles are removed and nobody is present in the working area and signing on LOTO log book.
- e) Only on confirmation of above the contractor will remove their lock and tag from the isolation points and give instructions for energizing the same. Only the person carrying out the task shall himself carry the key for the lock in /Lock out.

#### 4.0 DETAILS OF HSE MANAGEMENT SYSTEM BY CONTRACTOR

##### 4.1 On Award of Contract

The Contractor shall submit a comprehensive Health, Safety and Environmental Plan or programme for approval by EIL/Owner prior to start of work. The Contractor shall participate in the pre-start meeting with EIL/Owner to finalize HSE Plans which shall including the following:

- HSE policy & Objectives
- Job procedure to be followed by the Contractor for construction activities including handling of equipment's, scaffolding, electric installations, etc. describing the risks involved, actions to be taken and methodology for monitoring each activity. Indicative list of procedures is enclosed as Annexure-H
- EIL/Owner review/audit requirement.
- Organization structure along with responsibility and authority, on HSE activities.
- Administrative & disciplinary steps involving implementation of HSE requirements
- Emergency evacuation plan/ procedures for site and labour camps
- Procedures for reporting & investigation of accidents and near misses.
- HSE Inspection
- HSE Training programme at project site
- HSE Awareness program at project site
- Reference to Rules, Regulations and statutory requirements.
- HIRAC
- Environment Aspect Impact Register
- Legal Register
- HSE documentation viz reporting, analysis & record keeping.

##### 4.2 During Job Execution

Contractor shall implement approved Health, Safety and Environment management plan or programme including but not limited to as brought out under para 3.0. Contractor shall also ensure:

- a) to arrange workmen compensation insurance, registration under ESI Act, third party liability insurance, registration under BOCW Act etc., as applicable.

- b) to arrange all HSE permits before start of activities (as applicable), like permits for hot work, working at heights (Refer Format No. HSE-6), confined space (Refer Format No. HSE-7), Radiation Work Permit (Refer Format No. HSE-8), Demolishing/ Dismantling Work Permit (Refer Format No. HSE-9), Permit for erection/modification & dismantling of scaffolding (Refer Format No: HSE-14), Permit for heavy lift/critical erection (Refer Format No: HSE-15), Permit for energy Isolation & De-isolation” (HSE-16), storage of chemical/explosive materials & its use and implement all precautions mentioned therein. In this regard, requirements of *Oil industry Safety Directorate Standard No. Std -105 "Work Permit Systems"* shall be complied with while working in existing Oil or Gas processing plants. List of the persons involved shall be maintained as annexure to the work permit issued for a particular activity.
- c) to submit, timely, the completed checklist on HSE activities in Format No. HSE-1, Monthly HSE report in Format No. HSE-5 (use of web based package ([www.eil.co.in/conthse](http://www.eil.co.in/conthse)) is compulsory wherever the facility is available else a hard copy is to be submitted), accident/incident reports, investigation reports etc. as per EIL/Owner requirements. Compliance of instructions on HSE shall be done by Contractor and informed urgently to EIL/Owner.
- d) that his top most executive at site attends all the Safety Committee/HSE meetings arranged by EIL/Owner and carries out safety walk regularly. Only in case of his absence from site that a second senior most person shall be nominated by him, in advance, and communicated to EIL/Owner for performing the above tasks.
- e) display at site office and at prominent locations HSE Policy, caution boards, list of hospitals, emergency services available, safety signs like Men at work, Speed Limits, Hazardous Area, various do's & don'ts, etc.
- f) provide posters, banners for safe working to promote safety consciousness.
- g) identify, assess, analyze & mitigate the construction hazards & incorporate relevant control measures before actually executing site works. (HIRAC = Hazard Identification, Risk Analysis and Control).
- h) identify, assess, analyze & mitigate the environmental impact & incorporate relevant control measures through Environmental Aspect Impact Register
- i) Identify and comply to all applicable HSE related legal requirements by preparing and maintaining a Legal register.
- j) To maintain & monitor the level of legal compliance at site, a committee shall be formed comprising of contractor's RCM as Head and lead representatives as member(s) from HR/Legal, HSE and discipline engineer(s) (Civil, Mechanical, Electrical, Instrumentation) as applicable. Committee shall review the applicable legal requirements during periodical meetings and monitor the compliance status.
- k) arrange testing, examination, inspection of own as well as borrowed construction equipment's/ machinery (stationary & mobile) before being used at site and also at periodical interval, through own resources and also by 3<sup>rd</sup> party competent agencies (as deemed fit in statutes). Records of such test, examination etc. shall be maintained & shall be submitted to EIL/Owner as & when asked for.
- l) carryout audits/inspection (internal & external) at his works as well as sub-contractor works as per approved HSE plan/procedure/programme & submit the compliance reports of identified shortfalls for EIL/Owner review.
- m) Arranging HSE training for site workmen (of his own & subcontractors) through internal or external faculty at periodical intervals.
- n) Assistance & cooperate during HSE audits by EIL/Owner or any other 3<sup>rd</sup> party and submit compliance report.
- o) Generate & submit of HSE records/report as per this specification.
- p) Contractor shall arrange minimum 100 lux. illumination level at construction site for night works & record shall be maintained.

- q) Mobile phones shall not be permitted in operational area of the Project Site. However, intrinsically safe mobile phone can be permitted on approval from EIL/Owner. Alternatively, telephone booth(s) may be set up by the contractor after obtaining approval from EIL/Owner. Use of mobile phone shall also be restricted during construction activities such as height work, erection of material, confined space and Pre-commissioning & Commissioning activities at all project sites.
- r) The contractor shall assign responsible person as in charge for night works and it shall be informed to owner/EIL.
- s) Appraise EIL/Owner on HSE activities at site regularly.
- t) Carry-out all dismantling activities safely, with prior approval of EIL/Owner representative.
- u) The Contractor shall ensure that "Hot works" and painting works do not continue at the same place/ location at project site for which chance or probability of "fire" incident exists.

#### 4.3 During Short Listing of the Sub-Contractors

The contractor shall review the HSE management system of the sub-contractors in line with the requirements given in this specification. The contractor shall be held responsible for the shortcomings observed in the HSE management system of the sub-contractor(s) during execution of the job.

#### 5.0 RECORDS

At the minimum, the contractor shall maintain/ submit HSE records in the following reporting formats:

Safety Walk Through Report	HSE-1
Accident/ Incident Report	HSE-2
Supplementary Accident/ Incident Investigation report	HSE-3
Near Miss Incident Report	HSE-4
Monthly HSE Report	HSE-5
Permit for working at height	HSE-5
Permit for working in confined space	HSE-7
Permit for radiation work	HSE-8
Permit for demolishing/ dismantling	HSE-9
Daily Safety checklist	HSE-10
Housekeeping Assessment & compliance	HSE-11
Inspection of temporary electrical booth/installation	HSE-12
Inspection for scaffolding	HSE-13
Permit for erection/modification & dismantling of scaffolding	HSE-14
Permit for heavy lift/critical erection.	HSE-15
Permit for Energy isolation and de-isolation.	HSE-16
Permit for Excavation	HSE-17
Environmental Aspect Impact Register	HSE-18
HIRAC Register	HSE-19
Checklist for Tower Crane	HSE-20
Crane Inspection Checklist	HSE-21
Hydraulic Mobile Crane Inspection Checklist	HSE-22
Hydraulic Rig Inspection Checklist	HSE-23



Boom Lift Inspection Checklist	HSE-24
Inspection reports of Equipment/tools/tackles	*
Report of Toolbox Talks	As indicated in specification
PPE issue report/register	*
Site inspection reports	*
Training records	*

(\* ) The formats shall be developed by contractor in consultation with EIL/Owner.

APPENDIX-A  
(Sheet 1 of 2)

A. IS CODES ON HSE

SP: 53	Safety code for the use, Care and protection of hand operated tools.
IS: 838	Code of practice for safety & health requirements in electric and gas welding and cutting operations
IS: 1179	Eye & Face precautions during welding, equipment etc.
IS: 1860	Safety requirements for use, care and protection of abrasive grinding wheels.
IS: 1989 (Pt -II)	Leather safety boots and shoes
IS: 2925	Industrial Safety Helmets
IS: 3016	Code of practice for fire safety precautions in welding & cutting operation.
IS: 3043	Code of practice for earthing
IS: 3764	Code of safety for excavation work
IS: 3786	Methods for computation of frequency and severity rates for industrial injuries and classification of industrial accidents
IS: 3696	Safety Code of scaffolds and ladders
IS: 4083	Recommendations on stacking and storage of construction materials and components at site
IS: 4770	Rubber gloves for electrical purposes
IS: 5121	Safety code for piling and other deep foundations
IS: 5216 (Pt-I)	Recommendations on Safety procedures and practices in electrical works
IS: 5557	Industrial and Safety rubber lined boots
IS: 5983	Eye protectors
IS: 6519	Selection, care and repair of Safety footwear
IS: 6994 (Pt-I)	Industrial Safety Gloves (Leather & Cotton Gloves)
IS: 7293	Safety Code for working with construction Machinery
IS: 8519	Guide for selection of industrial safety equipment for body protection
IS: 9167	Ear protectors
IS: 11006	Flash back arrestor (Flame arrestor)
IS: 11016	General and safety requirements for machine tools and their operation
IS: 11057	Specification for Industrial safety nets
IS: 11226	Leather safety footwear having direct moulded rubber sole
IS: 11972	Code of practice for safety precaution to be taken when entering a sewerage system
IS: 13367	Code of practice-safe use of cranes
IS: 13416	Recommendations for preventive measures against hazards at working place

APPENDIX-A  
(Sheet 2 of 2)

B. INTERNATIONAL STANDARDS ON HSE

Safety Glasses	:	ANSI Z 87.1, ANSI ZZ 87.1, AS 1337, BS 2092, BS 1542, BS 679, DIN 4646/ 58311
Safety Shoes	:	ANSI Z 41.1, AS 2210, EN 345
Hand Gloves	:	BS 1651
Ear Muffs	:	BS 6344, ANSI S 31.9
Hard Hat	:	ANSI Z 89.1/89.2, AS 1808, BS 5240, DIN 4840
Goggles	:	ANSI Z 87.1
Face Shield	:	ANSI Z 89.1
Breathing Apparatus	:	BS 4667, NIOSH
Welding & Cutting	:	ANSI Z49.1
Safe handling of compressed:P-1		(Compressed Gas Association Gases in cylinders 1235 Jefferson Davis Highway, Arlington VA 22202 - USA)
Full body harness	:	EN-361
Lanyard	:	EN-354
Karabiner	:	EN-362 and EN-12275

APPENDIX-B

DETAILS OF FIRST AID BOX

SL. NO.	DESCRIPTION	QUANTITY
1.	Small size Roller Bandages, 1 Inch Wide (Finger Dressing small)	6 Pcs.
2.	Medium size Roller Bandages, 2 Inches Wide (Hand & Foot Dressing)	6 Pcs.
3.	Large size Roller Bandages, 4 Inches Wide (Body Dressing Large)	6 Pcs.
4.	Large size Burn Dressing (Burn Dressing Large)	4 Pkts.
5.	Cotton Wool (20 gms packing)	4 Pkts.
6.	Antiseptic Solution Dettol (100 ml.) or Savlon	1 Bottle
7.	Mercurochrome Solution (100 ml.) 2% in water	1 Bottle
8.	Ammonia Solution (20 ml.)	1 Bottle
9.	A Pair of Scissors	1 Piece
10.	Adhesive Plaster (1.25 cm X 5 m)	1 Spool
11.	Eye pads in Separate Sealed Pkt.	4 pcs.
12.	Tourniquet	1 No.
13.	Safety Pins	1 Dozen
14.	Tinc. Iodine/ Betadine (100 ml.)	1 Bottle
15.	Polythene Wash cup for washing eyes	1 No.
16.	Potassium Permanganate (20 gms.)	1 Pkt.
17.	Tinc. Benzoine (100 ml.)	1 Bottle
18.	Triangular Bandages	2 Nos.
19.	Band Aid Dressing	5 Pcs.
20.	Iodex/Moov(25 gms.)	1 Bottle
21.	Tongue Depressor	1 No.
22.	Boric Acid Powder (20 gms.)	2 Pkt.
23.	Sodium Bicarbonate (20 gms.)	1 Pkt.
24.	Dressing Powder (Nebasulf) (10 gms.)	1 Bottle
25.	Medicinal Glass	1 No.
26.	Duster	1 No.
27.	Booklet (English& Local Language)	1 No. each
28.	Soap	1 No.
29.	Toothache Solution	1 No.
30.	Vicks (22 gms.)	1 Bottle
31.	Forceps	1 No.
32.	Snake –Bite Lancet	1No.
33.	Note Book	1 No.
34.	Splints	4 Nos.
35.	Lock	1 Piece
36.	Life Saving/Emergency/Over-the counter Drugs	As decided at site

Box size: Suitable size first aid box to be used for first aid items

Note : The medicines prescribed above are only indicative. Equivalent medicines can also be used. A prescription, in this regard, shall be required from a qualified Physician.

APPENDIX-C

TYPE OF FIRES VIS-A-VIS FIRE EXTINGUISHERS

Fire Extinguisher → Fire ↓	Water	Foam	CO <sub>2</sub>	Dry Powder	Multi purpose (ABC)
Originated from paper, clothes, wood	✓	✓	can control minor surface fires	can control minor surface fires	✓
Inflammable liquids like alcohol, diesel, petrol, edible oils, bitumen	×	✓	✓	✓	✓
Originated from gases like LPG, CNG, H <sub>2</sub>	×	×	✓	✓	✓
Electrical fires	×	×	✓	✓	✓

LEGEND : ✓ : CAN BE USED

× : NOT TO BE USED

**Note:** Fire extinguishing equipment must be checked atleast once a year and after every use by an authorized person. The equipment must have an inspection label on which the next inspection date is given. Type of extinguisher shall clearly be marked on it.

APPENDIX-D

**List of Statutory Acts & Rules Relating to HSE**

- The Indian Explosives Act and Rules
- The Motor Vehicle Act and Central Motor Vehicle Rules
- The Factories Act and concerned Factory Rules
- The Petroleum Act and Petroleum Rules
- The Workmen Compensation Act
- The Gas Cylinder Rules and the Static & Mobile Pressure Vessels Rules
- The Indian Electricity Act and Rules
- The Indian Boiler Act and Regulations
- The Water (Prevention & Control & Pollution) Act
- The Water (Prevention & Control of Pollution) Cess Act
- The Mines & Minerals (Regulation & Development) Act
- The Air (Prevention & Control of Pollution) Act
- The Atomic Energy Act
- The Radiation Protection Rules
- The Indian Fisheries Act
- The Indian Forest Act
- The Wild Life (Protection) Act
- The Environment (Protection) Act and Rules
- The Hazardous Wastes (Management & Handling) Rules
- The Manufacturing, Storage & import of Hazardous Chemicals Rules
- The Public Liability Act
- The Building and Other Construction Workers (Regulation of Employment and Condition of Service) Act
- Other statutory acts Like EPF, ESIS, Minimum Wages Act.

APPENDIX-E(Sheet 1 of 12)

CONSTRUCTION HAZARDS, THEIR EFFECTS & PREVENTIVE MEASURES

ACTIVITY	TYPE OF HAZARD	EFFECT OF HAZARD	PREVENTIVE MEASURES
(A) EXCAVATION  Pit Excavation upto 3.0m	Falling into pit	Personal injury	Provide guard rails/ barricade with warning signal Provide atleast two entries/ exits. Provide escape ladders.
	Earth Collapse	Suffocation/ Breathlessness Buried	Provide suitable size of shoring and strutting, if required. Keep soil heaps away from the edge equivalent to 1.5m or depth of pit whichever is more. Don't allow vehicles to operate too close to excavated areas. Maintain atleast 2m distance from edge of cut. Maintain sufficient angle of repose. Provide slope not less than 1:1 and suitable bench of 0.5m width at every 1.5m depth of excavation in all soils except hard rock. Battering/benching the sides.
	Contact with buried electric cables Gas/ Oil Pipelines	Electrocution Explosion	Obtain permission from competent authorities, prior to excavation, if required. Locate the position of buried utilities by referring to plant drawings. Start digging manually to locate the exact position of buried utilities and thereafter use mechanical means.
Pit Excavation beyond 3.0m	Same as above plus Flooding due to excessive rain/ underground water	Can cause drowning situation	Prevent ingress of water Provide ring buoys Identify and provide suitable size dewatering pump or well point system
	Digging in the vicinity of existing Building/ Structure	Building/Structure may collapse Loss of health & wealth	Obtain prior approval of excavation method from local authorities. Use under-pining method Construct retaining wall side by side.
	Movement of vehicles/ Equipments close to the edge of cut.	May cause cave-in or slides. Persons may get buried.	Barricade the excavated area with proper lighting arrangements Maintain at least 2m distance from edge of cut and use stop blocks to prevent over-run Strengthen shoring and strutting

APPENDIX-E: (Sheet 2 of 12)

CONSTRUCTION HAZARDS, THEIR EFFECTS & PREVENTIVE MEASURES (...Contd.)

ACTIVITY	TYPE OF HAZARD	EFFECT OF HAZARD	PREVENTIVE MEASURES
Narrow deep excavations for pipelines, etc.	Same as above plus Frequent cave-in or slides	May cause severe injuries or prove fatal	Battering/benching of sides Provide escape ladders
	Flooding due to Hydro- static testing	May arise drowning situation	Same as above plus Bail out accumulated water Maintain adequate ventilation.
Rock by excavation blasting	Improper handling of explosives	May prove fatal	Ensure proper storage, handling & carrying of explosives by trained personnel. Comply with the applicable explosive acts & rules.
	Uncontrolled explosion	May cause severe injuries or prove fatal	Allow only authorized persons to perform blasting operations. Smoking and open flames are to be strictly prohibited
	Scattering of stone pieces in atmosphere	Can hurt people	Use PPE like goggles, face mask, helmets etc:
Rock excavation by blasting (Contd)	Entrapping of persons/ animals.	May cause severe injuries or prove fatal	Barricade the area with red flags and blow siren before blasting.
	Misfire	May explode suddenly	Do not return to site for atleast 20 minutes or unless announced safe by designated person.
Piling Work	Failure of pile-driving equipment	Can hurt people	Inspect Piling rigs and pulley blocks before the beginning of each shift.
	Noise pollution	Can cause deafness and psychological imbalance.	Use personal protective equipment's like ear plugs, muffs, etc.
	Extruding rods/casing	Can hurt people	Barricade the area and install sign boards Provide first-aid
	Working in the vicinity of 'Live-Electricity'	Can cause electrocution/ Asphyxiation	Keep sufficient distance from Live-Electricity as per IS code. Shut off the supply, if possible Provide artificial/rescue breathing to the injured
(B) CONCRETING	Air pollution by cement	May affect Respiratory System	Wear respirators or cover mouth and nose with wet cloth.
	Handling of ingredients	Hands may get injured	Use gloves & other PPE.
	Protruding reinforcement rods.	Feet may get injured	Provide platform above reinforcement for movement of workers or provide end caps for protection on reinforcement bars.

APPENDIX-E :(Sheet 3 of 12)

CONSTRUCTION HAZARDS, THEIR EFFECTS & PREVENTIVE MEASURES (...Contd.)

ACTIVITY	TYPE OF HAZARD	EFFECT OF HAZARD	PREVENTIVE MEASURES
	Earthing of electrical mixers, vibrators, etc. not done.	Can cause electrocution/ asphyxiation	Ensure earthing of equipments and proper functioning of electrical circuit before commencement of work.
	Falling of materials from height	Persons may get injured	Use hard hats Remove surplus material immediately from work place. Ensure lighting arrangements during night hours
	Continuous pouring by same gang	Cause tiredness of workers and may lead to accident.	Insist on shift pattern Provide adequate rest to workers between subsequent pours.
	Revolving of concrete mixer/ vibrators	Parts of body or clothes may get entrapped.	Allow only mixers with hopper Provide safety cages around moving motors Ensure proper mechanical locking of vibrator.
Super-structure	Same as above plus Deflection in props or shuttering material	Shuttering/props may collapse and prove fatal	Avoid excessive stacking on shuttering material Check the design and strength of shuttering material before commencement of work Rectify immediately the deflection noted during concreting.
	Passage to work place	Improperly tied and designed props/planks may collapse	Ensure the stability and strength of passage before commencement of work. Do not overload and stand under the passage.
(C) REINFOR-CEMENT	Curtailement and binding of rods	Persons may get injured	Use PPE like gloves, shoes, helmets, etc. Avoid usage of shift tools
	Carrying of rods for short distances/at heights	Workers may get injured their hands and shoulders.	Provide suitable pads on shoulders and use safety gloves. Tie up rods in easily liftable bundles Ensure proper staging.
	Checking of clear distance/ cover with hands	Rods may cut or injure the fingers	Use measuring devices like tape, measuring rods, etc.
	Hitting projected rods and standing on cantilever rods.	Persons may get injured and fell down	Use safety shoes and avoid standing unnecessarily on cantilever rods Avoid wearing of loose clothes

APPENDIX-E:(Sheet 4 of 12)

CONSTRUCTION HAZARDS, THEIR EFFECTS & PREVENTIVE MEASURES (...Contd.)

ACTIVITY	TYPE OF HAZARD	EFFECT OF HAZARD	PREVENTIVE MEASURES
	Falling of material from height	May prove fatal	Use helmets Provide safety nets.
	Transportation of rods by trucks/ trailers	Protruded rods may hit the persons	Use red flags/lights at the ends Do not protrude the rods in front of or by the side of driver's cabin. Do not extend the rods 1/3 <sup>rd</sup> of deck length or 1.5m whichever is less
(D)WELDING AND GAS CUTTING	Welding radiates invisible ultraviolet and infra-red rays	Radiation can damage eyes and skin.	Use specified shielding devices and other PPE of correct specifications. Avoid thoriated tungsten electrodes for GTAW
	Improper placement of oxygen and acetylene cylinders	Explosion may occur	Move out any leaking cylinder Keep cylinders in vertical position Use trolley for transportation of cylinders and chain them Use flashback arrestors
	Leakage/ cuts in hoses	May cause fire	Purge regulators immediately and then turn off Never use grease or oil on oxygen line connections and copper fittings on acetylene lines Inspect regularly gas carrying hoses Always use red hose for acetylene & other fuel gases and black for oxygen
	Opening-up of cylinder	Cylinder may burst	Always stand back from the regulator while opening the cylinder Turn valve slowly to avoid bursting Cover the lug terminals to prevent short circuiting
	Welding of tanks, container or pipes storing flammable liquids	Explosion may occur	Empty & purge them before welding Never attach the ground cable to tanks, container or pipe storing flammable liquids Never use LPG for gas cutting

APPENDIX-E:(Sheet 5 of 12)

CONSTRUCTION HAZARDS, THEIR EFFECTS & PREVENTIVE MEASURES ...(Contd.)

ACTIVITY	TYPE OF HAZARD	EFFECT OF HAZARD	PREVENTIVE MEASURES
(E) RADIOGRAPHY	Ionizing radiation	Radiations may react with the skin and can cause cancer, skin irritation, dermatitis, etc.	Ensure Safety regulations as per BARC/AERB before commencement of job. Cordon off the area and install Radiation warning symbols Restrict the entry of unauthorized persons Wear appropriate PPE and film badges issued by BARC/AERB
	Transportation and Storage of Radiography source	Same as above	Never touch or handle radiography source with hands Store radiography source inside a pit in an exclusive isolated storage room with lock and key arrangement. The pit should be approved by BARC/AERB. Radiography source should never be carried either in passenger bus or in a passenger compartment of trains. BARC/AERB has to be informed before source movement. Permission from Director General of Civil Aviation is required for booking radio isotopes with airlines.
	Loss of Radio isotope	Same as above	Try to locate with the help of Survey Meter. Inform BARC/AERB (*)
(F) ELECTRICAL INSTALLATION AND USAGE	Short circuiting	Can cause Electrocution or Fire	Use rubberized hand gloves and other PPE Don't lay wires under carpets, mats or door ways. Allow only licensed electricians to perform on electrical facilities Use one socket for one appliance Ensure usage of only fully insulated wires or cables Don't place bare wire ends in a socket Ensure earthing of machineries and equipment's Do not use damaged cords and avoid temporary connections Use spark-proof/flame proof type field distribution boxes.

(\*) Atomic Energy Regulatory Board (AERB),  
Bhabha Atomic Research Centre (BARC)  
Anushakti Nagar, Mumbai – 400 094

APPENDIX-E:(Sheet 6 of 12)

CONSTRUCTION HAZARDS, THEIR EFFECTS & PREVENTIVE MEASURES (...Contd.)

ACTIVITY	TYPE OF HAZARD	EFFECT OF HAZARD	PREVENTIVE MEASURES
			Do not allow open/bare connections Provide all connections through 30mAELCB Protect electrical cables/equipments from water and naked flames Check all connections before energizing
	Overloading of Electrical System	Bursting of system can occur which leads to fire	Display voltage and current ratings prominently with 'Danger' signs. Ensure approved cable size, voltage grade and type Switch off the electrical utilities when not in use Do not allow unauthorized connections. Ensure proper grid wise distribution of Power
	Improper laying of overhead and underground transmission lines/cables	Can cause electrocution and prove fatal	Do not lay un armoured cable directly on ground, wall, roof of trees Maintain atleast 3m distance from HT cables All temporary cables should be laid atleast 750 mm below ground on 100 mm fine sand overlying by brick soling Provide proper sleeves at crossings/ inter-sections Provide cable route markers indicating the type and depth of cables at intervals not exceeding 30m and at the diversions/termination
(G) FIRE PREVENTION AND PROTECTION	Small fires can become big ones and may spread to the surrounding areas	Cause burn injuries and may prove fatal	In case a fire breaks out, press fire alarm system and shout "Fire, Fire". Keep buckets full of sand & water/ fire extinguishing equipment near hazardous locations. Confine smoking to 'Smoking Zones' only. Train people for using specific type of fire fighting equipments under different classes of fire. Keep fire doors/shutters, passages and exit doors unobstructed. Maintain good housekeeping and first-aid boxes (for details refer Appendix-B). Don't obstruct access to Fire extinguishers. Do not use elevators for evacuation during fire. Maintain lightning arrestors for elevated structures. Stop all electrical motors with internal combustion.

APPENDIX-E :(Sheet 7 of 12)

CONSTRUCTION HAZARDS, THEIR EFFECTS & PREVENTIVE MEASURES (...Contd.)

ACTIVITY	TYPE OF HAZARD	EFFECT OF HAZARD	PREVENTIVE MEASURES
			Move the vehicles from dangerous locations. Remove the load hanging from the crane booms Remain out of the danger areas.
	Improper selection of Fire extinguisher	It may not extinguish the fire	Ensure usage of correct fire extinguisher meant for the specified fire (for details refer Appendix-C). Do not attempt to extinguish Oil and electric fires with water. Use foam cylinders/CO <sub>2</sub> /sand or earth.
	Improper storage of highly inflammable substances	Same as above	Maintain safe distance of flammable substances from source of ignition. Restrict the distribution of flammable materials to only min. necessary amount. Construct specifically designed fuel storage facilities. Keep chemicals in cool and dry place away from heat. Ensure adequate ventilation. Before welding operation, remove or shield the flammable material properly. Store flammable materials in stable racks, correctly labeled preferably with catchment trays. Wipe off the spills immediately
	Short circuiting of electrical system	Same as above Can cause Electrocutation	Don't lay wires under carpets, mats or door ways Use one socket for one appliance. Use only fully insulated wires or cables. Do not allow open/bare connections. Provide all connections through 30mAELCB. Ensure earthing of machineries and equipments.
(H) VEHICULAR MOVEMENT	Crossing the Speed Limits (Rash driving)	Personal injury	Obey speed limits and traffic rules strictly. Always expect the unexpected and be a defensive driver. Use seat belts/helmets. Blow horn at intersections and during overtaking operations. Maintain the vehicle in good condition. Do not overtake on curves, bridges and slopes.
	Adverse weather condition	Same as Above	Read the road ahead and ride to the left. Keep the wind screen and lights clean. Do not turn at speed. Recognize the hazard, understand the defense and act correctly in time.

APPENDIX-E :(Sheet 8 of 12)

CONSTRUCTION HAZARDS, THEIR EFFECTS & PREVENTIVE MEASURES (...Contd.)

ACTIVITY	TYPE OF HAZARD	EFFECT OF HAZARD	PREVENTIVE MEASURES
	Consuming alcohol before and during the driving operation	Same as above	Alcohol and driving do not mix well. Either choose alcohol or driving. If you have a choice between hitting a fixed object or an on-coming vehicle, hit the fixed object Quit the steering at once and become a passenger. Otherwise take sufficient rest and then drive. Do not force the driver to drive fast and round the clock. Do not day dream while driving
	Falling objects/ Mechanical failure	May prove fatal	Ensure effective braking system, adequate visibility for the drives, reverse warning alarm. Proper maintenance of the vehicle as per manufacturer instructions
(I) PROOF TESTING (HYDROSTATIC/PNEUMATIC TESTING)	Bursting of piping Collapse of tanks Tanks flying off	May cause injury and prove fatal	Prepare test procedure & obtain EIL/owner's approval. Provide separate gauge for pressurizing pump and piping/equipment. Check the calibration status of all pressure gauges, dead weight testers and temperature recorders. Take dial readings at suitable defined intervals and ensure most of them fall between 40-60% of the gauge scale range. Provide safety relief valve (set at pressure slightly higher than test pressure) while testing with air/ nitrogen. Ensure necessary precautions, stepwise increase in pressure, tightening of bolts/nuts, grouting, etc. before and during testing. Keep the vents open before opening any valve while draining out of water used for hydro-testing of tanks. Pneumatic testing involves the hazard of released energy stored in compressed gas. Specific care must therefore be taken to minimize the chance of brittle failure during a pneumatic leak test. Test temperature is important in this regard and must be considered when the designer chooses the material of construction.

APPENDIX-E :(Sheet 9 of 12)

CONSTRUCTION HAZARDS, THEIR EFFECTS & PREVENTIVE MEASURES (...Contd.)

ACTIVITY	TYPE OF HAZARD	EFFECT OF HAZARD	PREVENTIVE MEASURES
			A pressure relief device shall be provided, having a set pressure not higher than the test pressure plus the lesser of 345 KPa (50 psi) or 10% of the test pressure. The gas used as test fluid, if not air, shall be nonflammable and nontoxic.
(J) WORKING AT HEIGHTS	Person can fall down	May sustain severe injuries or prove fatal	Provide guard rails/barricade at the work place Use PPE like full body harness, life line, helmets, safety shoes, etc. Obtain a permit before starting the work at height above 2 meters Fall arrest and safety nets, etc. must be installed Provide adequate working space(min. 0.6 m) Tie/weld working platform with fixed support Use roof top walk ladder while working on a slopping roofs Avoid movement on beams
		May hit the scrap/material stacked at the ground or in between	Keep the work place neat and clean Remove the scrap immediately
	Material can fall down	May hit the workers working at lower levels and prove fatal	Same as above plus Do not throw or drop materials or equipment from height. i.e. do not <i>bomb</i> materials All tools to be carried in a tool-kit Bag or on working uniform Remove scrap from the planks Ensure wearing of helmet by the workers working at lower levels. Multiple activities at same location to be avoided.
(K) CONFINED SPACES	Suffocation/ drowning	Unconsciousness, death	Use respiratory devices, if reqd. Avoid overcrowding inside a confined space Provide Exhaust fans for ventilation Do not wear loose clothes, neck ties, etc. Fulfill conditions of the permit

APPENDIX-E:(Sheet 10 of 12)

CONSTRUCTION HAZARDS, THEIR EFFECTS & PREVENTIVE MEASURES (...Contd.)

ACTIVITY	TYPE OF HAZARD	EFFECT OF HAZARD	PREVENTIVE MEASURES
			Check for presence of hydrocarbons, O <sub>2</sub> level Obtain work permit before entering a confined space Ensure that the connected piping of the equipment which is to be opened is pressure free, fluid has been drained, vents are open and piping is positively isolated by a blind flange
	Presence of foul smell and toxic substances	Inhalation can pose threat to life	Same as above plus Check for hydrocarbon and Aromatic compounds before entering a confined space Depute one person outside the confined space for continuous monitoring and for extending help in case of an emergency
	Ignition/ flame can cause fire	Person may sustain burn injuries or explosion may occur	Keep fire extinguishers at a hand distance Remove surplus material and scrap immediately Do not smoke inside a confined space Do not allow gas cylinders inside a confined space Use low voltage (24V) lamps for lighting Use tools with air motors or electric tools with max. voltage of 24V Remove all equipment's at the end of the day
(L) HANDLING AND LIFTING EQUIPMENTS	Failure of load lifting and moving equipment's	Can cause accident and prove fatal	Avoid standing under the lifted load and within the operating radius of cranes. Check periodically oil, brakes, gears, horns and tyre pressure of all moving machinery. Check quality, size and condition of all chain pulley blocks, slings, U-clamps, D-shackles, wire ropes, etc. Allow crane to move only on hard, firm and leveled ground. Allow lifting slings as short as possible and check gunny packings at the friction points. Do not allow crane to tilt its boom while moving Install Safe Load Indicator. Ensure certification by applicable authority.

APPENDIX-E :(Sheet 11 of 12)

CONSTRUCTION HAZARDS, THEIR EFFECTS & PREVENTIVE MEASURES (...Contd.)

ACTIVITY	TYPE OF HAZARD	EFFECT OF HAZARD	PREVENTIVE MEASURES
	Overloading of lifting equipments	Same as above	Safe lifting capacity of derricks and winches written on them shall be got verified The max. safe working load shall be marked on all lifting equipments Check the weight of columns and other heavy items painted on them and accordingly decide about the crane capacity, boom and angle of erection Allow only trained operators and riggers during crane operation.
	Overhead electrical wires	Can cause electrocution and fire	Do not allow boom or other parts of crane to come within 3m reach of overhead HT cables Hook and load being lifted shall preferably remain in full visibility of crane operators.
(M) SCAFFOLDING, FORMWORK AND LADDERS	Person can fall down	Person May sustain severe injuries and prove fatal	Provide guard rails for working at height. Face ladder while climbing and use both hands. Ladders shall extend about 1m above landing for easy access and tying up purpose. Do not place ladders against movable objects and maintain base at 1/4 unit of the working length of the ladder. Suspended scaffolds shall not be less than 500 mm wide and tied properly with ropes. No loose planks shall be allowed. Use PPE, like helmets, safety shoes etc.
	Failure of scaffolding material	Same as above	Inspect visually all scaffolding materials for stability and anchoring with permanent structures. Design scaffolding for max. load carrying capacity. Scaffolding planks shall not be less than 50X250 mm full thickness lumber or equivalent. These shall be cleated or secured and must extend over the end supports by at least 150mm and not more than 300mm. Don't overload the scaffolds. Do not splice short ladders to make a longer one. Vertical ladders shall not exceed 6m.
	Material can fall down	Persons working at lower level gets injured	Remove excess material and scrap immediately. Carry the tools in a tool-kit bag only. Provide safety nets.

APPENDIX-E:(Sheet 12 of 12)

CONSTRUCTION HAZARDS, THEIR EFFECTS & PREVENTIVE MEASURES (...Contd.)

ACTIVITY	TYPE OF HAZARD	EFFECT OF HAZARD	PREVENTIVE MEASURES
(N) STRUC- TURAL WORKS	Personal negligence and danger of fall	Can cause injury or casualty	Do not take rest inside rooms built for welding machines or electrical distribution system. Avoid walking on beams at height. Wear helmet with chin strap and full body harness while working at height. Use hand gloves and goggles during grinding operations. Cover or mark the sharp and projected edges. Do not stand within the operating radius of cranes.
	Lifting/ slipping of material	Same as above	Do not stand under the lifted load. Stack properly all the materials. Avoid slippage during handling. Control longer pieces lifted up by cranes from both ends. Remove loose materials from height. Ensure tightening of all nuts & bolts.
(O)PIPELIN E WORKS	Erection/ lowering failure	Can cause injury	Do not stand under the lifted load. Do not allow any person to come within the radii of the side boom handling pipes. Check the load carrying capacity of the lifting tools & tackles. Use safe Load Indicators (SLI). Use appropriate PPEs.
	Other	Same as above	Wear gum boots in marshy areas. Allow only one person to perform signaling operations while lowering of pipes. Wedges to be provided below the pipe to prevent spool/pipe roll out. Provide night caps on pipes. Provide end covers on pipes for stoppage of pigs while testing/ cleaning operations.
(P) GRIT BLASTING	Pollution in neighboring area, hit by grit sand high pressure air	Can cause personal injury	Ensure the blasting is done in enclosed shed. Keep safe distance while blasting operations. Wear positive pressure blast hood or helmet with view-window, ear-muff/plug, gloves, overall or leather coat /apron, rubber shoes.

APPENDIX-F

TRAINING SUBJECTS / TOPICS

(For contractors' personnel)

1. The Law & Safety – Statutory Requirement / Applicable statutes / Duties of employer / employee.
2. Policy & Administration – Why HSE? / Duties & Responsibilities of Safety Personnel at project site / Effect of incentive on accident prevention.
3. HSE & Supervision – Duties of Supervisor / HSE integrated supervision / Who should be held responsible for site accidents?
4. Safety Budget / Cost of Accidents – Direct costs / Indirect costs.
5. Hazard Identification / Type of hazards / HIRAC.
6. Behavioral Safety & Motivation.
7. Housekeeping – Storage / Stacking / Handling of materials / Hydraulic Mobile Crane handling.
8. Occupational Health in Construction sector.
9. Personal Protective Equipment's – Respiratory & Non- respiratory.
10. Electricity & Safety – ELCB / Fuse / Powered tools / Project illumination.
11. Handling of Compressed Gas – Transportation / Storage / FBAs / Fire prevention.
12. Machine Safety – Machine guarding / Maintenance.
13. Transportation – Hazards & risks in transp. of materials / ODC consignments.
14. Cranes & Other Lifting machinery – Legal requirements vis-à-vis essential safety requirements.
15. Communication – HSE Induction / TBTs / Safety Committee / Safety meeting / Safety propaganda / Publicity.
16. Excavation – Risks & Dangers / Safety measures.
17. Working at Heights – Use of ladder / Work on roofs / Scaffolds / Double harness lanyards / Life-line / Fall arrester / Safety Nets / Floor openings.
18. Hazards in Welding & important safety precautions.
19. Gas Cutting – Hazards & safety measures.
20. Fire prevention & fire protection.

APPENDIX - G

CONSTRUCTION POWER BOARD(typ)

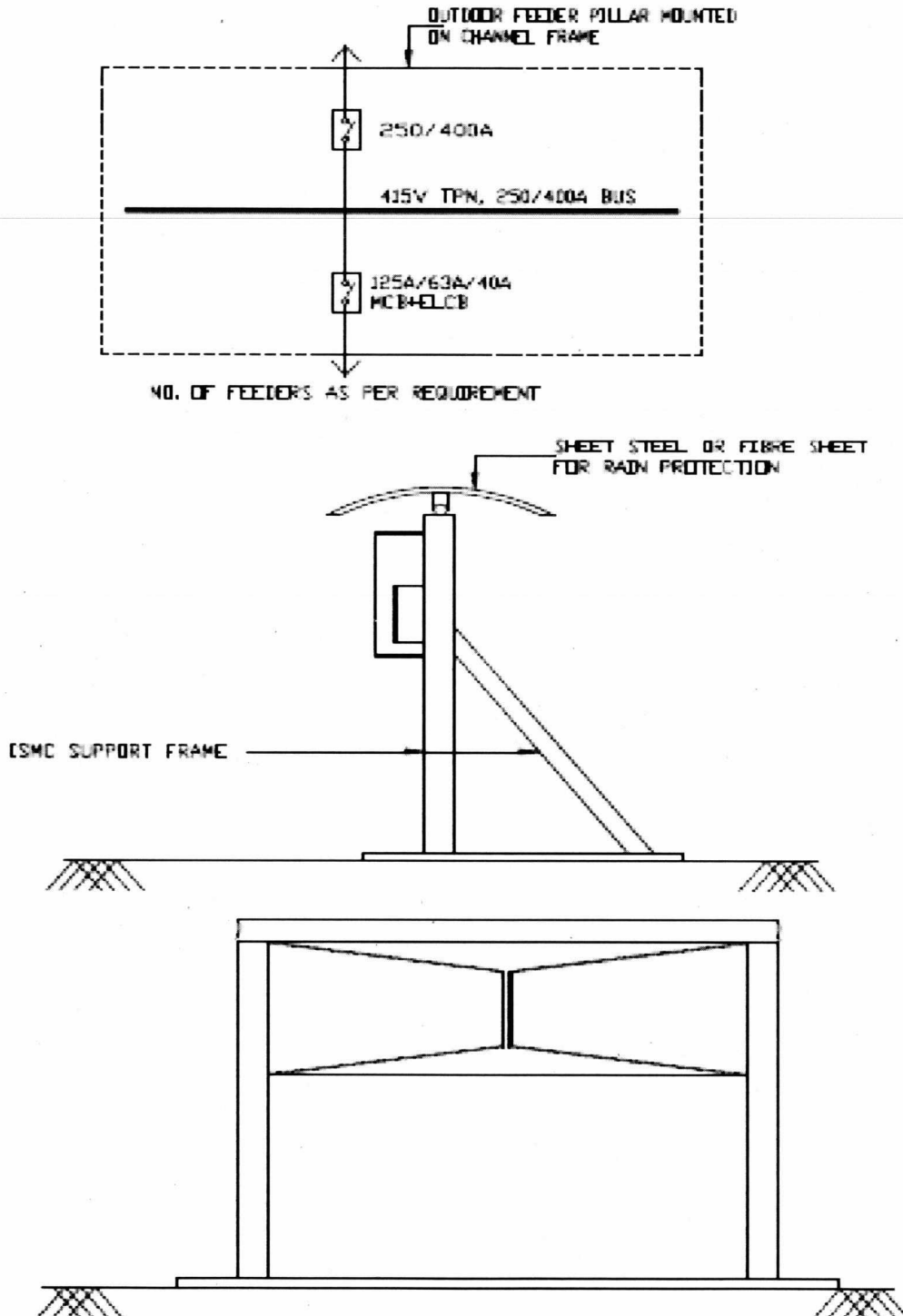

NOTES-

1. CONTRACTOR TO INSTALL TEMPORARY CONST. POWER BOARD AS SHOWN IN THE DRG. ITS LOCATION SHALL BE EASILY ACCESSABLE.
2. POWER DISTRIBUTION BOARD SHALL BE EARTHED AT TWO POINTS BY MINIMUM 40X5MM GI STRIP FROM THE AVAILBLE GRID. OR DIRECTLY CONNECTED TO TWO DIRECTLY DRIVEN EARTH ELECTRODES.
3. DISTRIBUTION BOARD SHALL BE FABRICATED BY USING 14MM CRCA SHEET STEEL WITH HINGED DOORS AND ALL COMPONENT MOUNTED IN IT.
4. ALL INCOMING AND OUTGOING CABLES SHALL HAVE BOTTOM ENTRY.

## APPENDIX-H

### LIST OF PROCEDURES (MINIMUM) TO BE FORMING PART OF HSE PLAN:-

A. HSE Management Procedures:

- HSE Risk Management (including HIRA)
- HSE Legal Compliance and Other Requirements
- HSE Objectives & Performance
- HSE Training and Competence (including Induction)
- HSE Motivation & Award Scheme
- HSE Audits
- HSE Sub Contractor Management
- HSE Emergency Management
- HSE Incidents Reporting and Management
- HSE procedure for Behaviour based Safety
- First Aid & Management
- Roles, Responsibility, accountabilities and Authorities

B. Job procedures/Safe Operating procedures

- Setting Up Site & Signages
- Working at Height
- Confined Space Entry
- Permit to Work (including hot works)
- Housekeeping
- Transportation of materials including Manual Handling
- Earthmoving Operations & excavation
- Scaffolding
- Fire Prevention/Protection
- Hazardous Substance handling & Storage
- Personal Protective Equipment

APPENDIX-I

LIFE SAVING RULES

<p><b>Bypassing Safety Controls</b></p> <p><b>Obtain authorisation before overriding or disabling safety controls</b></p>  <ul style="list-style-type: none"> <li>I understand &amp; use safety-critical equipment and procedure which apply to my task</li> <li>I obtain authorization before: <ul style="list-style-type: none"> <li>disabling or overriding safety equipment</li> <li>deviating from procedures</li> <li>crossing a barrier</li> </ul> </li> </ul>	<p><b>Confined Space</b></p> <p><b>Obtain authorisation before entering a confined space</b></p>  <ul style="list-style-type: none"> <li>I confirm energy sources are isolated</li> <li>I confirm the atmosphere has been tested and is monitored</li> <li>I check and use my breathing apparatus when required</li> <li>I confirm there is an attendant standing by</li> <li>I confirm rescue plan is in place</li> <li>I obtain authorization to enter</li> </ul>	<p><b>Driving</b></p> <p><b>Follow safe driving rules</b></p>  <ul style="list-style-type: none"> <li>I always wear a seatbelt</li> <li>I do not exceed the speed limit, and reduce my speed for road conditions</li> <li>I do not use phones or operate devices while driving</li> <li>I am fit, rested and fully alert while driving</li> <li>I follow journey management requirements</li> </ul>	
<p><b>Energy Isolation</b></p> <p><b>Verify isolation and zero energy before work begins</b></p>  <ul style="list-style-type: none"> <li>I have identified all energy sources</li> <li>I confirm that hazardous energy sources have been isolated, locked and tagged</li> <li>I have checked there is zero energy and tested for residual or stored energy</li> </ul>	<p><b>Hot Work</b></p> <p><b>Controls flammables and ignition sources</b></p>  <ul style="list-style-type: none"> <li>I identify and control ignition sources</li> <li>Before starting any hot work: <ul style="list-style-type: none"> <li>I confirm flammable material has been removed or isolated</li> <li>I obtain authorization</li> </ul> </li> <li>Before starting hot work in a hazardous area I confirm: <ul style="list-style-type: none"> <li>a gas test has been completed</li> <li>gas will be monitored continually</li> </ul> </li> </ul>	<p><b>Line of Fire</b></p> <p><b>Keep yourself and others out of the line of fire</b></p>  <ul style="list-style-type: none"> <li>I position myself to avoid: <ul style="list-style-type: none"> <li>moving objects</li> <li>vehicles</li> <li>pressure releases</li> <li>dropped objects</li> </ul> </li> <li>I establish and obey barriers and exclusion zones</li> <li>I take action to secure loose objects and report potential dropped objects</li> </ul>	
<p><b>Safe Mechanical Lifting</b></p> <p><b>Plan lifting operations and control the area</b></p>  <ul style="list-style-type: none"> <li>I confirm that the equipment and load have been inspected and are fit for purpose</li> <li>I only operate equipment that I am qualified to use</li> <li>I establish and obey barriers and exclusion zones</li> <li>I never walk under a suspended load</li> </ul>	<p><b>Work Authorization</b></p> <p><b>Work with a valid permit when required</b></p>  <ul style="list-style-type: none"> <li>I am authorised to perform the work</li> <li>I understand the permit</li> <li>I have confirmed that hazards are controlled and it is safe to start</li> <li>I stop and reassess if conditions change</li> </ul>	<p><b>Work at Height</b></p> <p><b>Protect yourself against a fall when working at height</b></p>  <ul style="list-style-type: none"> <li>I inspect my fall protection equipment before use</li> <li>I secure tools and work materials to prevent dropped objects</li> <li>I tie off 100% to approved anchor points while outside a protected area</li> </ul>	<p><b>Excavation</b></p> <p><b>Follow safe excavation procedure</b></p>  <ul style="list-style-type: none"> <li>Before starting any excavation: <ul style="list-style-type: none"> <li>I confirm availability of underground utilities</li> <li>I obtain authorization</li> <li>I take adequate precautions to prevent collapse of soil</li> </ul> </li> </ul>

FORMAT NO. : HSE-1 REV 1

(Sheet 1 of 6)

**SAFETY WALK-THROUGH REPORT**

(Name & signature of walk through performer to be inserted at the bottom of each page)

Project : \_\_\_\_\_ Report no. : \_\_\_\_\_  
 Date : \_\_\_\_\_ Contractor : \_\_\_\_\_  
 Inspection by : \_\_\_\_\_ Owner : \_\_\_\_\_  
 Frequency : Monthly Job no. : \_\_\_\_\_

Note : Write 'NA' wherever the item is not applicable

SL. NO.	ITEM	Satisfactory/ Yes	Non satisfactory/ No	Remarks	Action
1.	HOUSEKEEPING				
a)	Waste containers provided and used				
b)	Sanitary facilities adequate and Clean				
c)	Passageways and Walkways Clear				
d)	General neatness of working areas				
e)	Other				
2.	PERSONNEL PROTECTIVE EQUIPMENT				
a)	Goggles; Shields				
b)	Face protection				
c)	Hearing protection				
d)	Foot protection				
e)	Hand protection				
f)	Respiratory Masks etc.				
g)	Full body harness conforming to CE, EN 361				
h)	Hard hat (HDPE)				
i)	Other				
3.	EXCAVATIONS/OPENINGS				
a)	Openings properly covered or barricaded				
b)	Excavations shored				
c)	Excavations barricaded				
d)	Overnight lighting provided				
e)	Other				

Safety walk-through performer (Name & Signature).....

FORMAT NO. : HSE-1 REV 1

(Sheet 2 of 6)

SL. NO.	ITEM	Satisfactory/ Yes	Non satisfactory/ No	Remarks	Action
4.	WELDING & GAS CUTTING				
a)	Gas cylinders chained upright				
b)	Cables and hoses not obstructing				
c)	Screens or shields used				
d)	Flammable materials protected				
e)	Live electrode bits contained properly				
f)	Fire extinguisher (s) accessible				
g)	Other				
5.	SCAFFOLDING & BARRICADING				
a)	Fully decked platforms				
b)	Guard and intermediate rails in place				
c)	Toe boards in place				
d)	Adequate shoring				
e)	Adequate access				
f)	Positive barricading for critical activities				
g)	Installation of warning signs				
h)	Other				
6.	LADDERS				
a)	Extension side rails 1 m above				
b)	Top of landing				
c)	Properly secured				
d)	Angle + 70° from horizontal				
e)	Other				

Safety walk-through performer (Name & Signature).....

FORMAT NO. : HSE-1 REV 1

(Sheet 3 of 6)

SL. NO.	ITEM	Satisfactory/ Yes	Non satisfactory/ No	Remarks	Action
7.	HOISTS, CRANES AND DERRICKS				
a)	Condition of cables and sheaves OK				
b)	Condition of slings, chains, hooks and eyes O.K.				
c)	Inspection and maintenance log-books maintained				
d)	Outriggers used				
e)	Reverse horn installed / active / coupled with gear				
f)	Signs/barricades provided				
g)	Signals observed and understood				
h)	Qualified operators				
i)	Other				
8.	MACHINERY, TOOLS AND EQUIPMENT				
a)	Proper instruction				
b)	Safety devices				
c)	Proper cords				
d)	Inspection and maintenance				
e)	Other				
9.	VEHICLE AND TRAFFIC				
a)	Rules and regulations observed				
b)	Inspection and maintenance				
c)	Licensed drivers				
d)	Other				

Safety walk-through performer (Name & Signature).....

FORMAT NO. : HSE-1 REV 1

(Sheet 4 of 6)

SL. NO.	ITEM	Satisfactory/ Yes	Non satisfactory/ No	Remarks	Action
10.	TEMPORARY FACILITIES				
a)	Emergency instructions posted				
b)	Fire extinguishers provided				
c)	Fire-aid equipment available				
d)	Secured against storm damage				
e)	General neatness				
f)	In accordance with electrical requirements				
g)	Other				
11.	FIRE PREVENTION				
a)	Personnel trained & instructed to make use of facility				
b)	Fire extinguishers checked periodically & record maintained				
c)	No smoking in Prohibited areas.				
d)	Fire Hydrants not obstructed				
e)	Regular fire drill conducted				
12.	ELECTRICAL				
a)	Use of 3-core armored cables everywhere				
b)	Usage of 'All insulated' or 'double-insulated' electrical tools				
c)	All electrical connection are routed through ELCB				
d)	Natural Earthing at the source of power (Main DB)				
e)	Continuity and tightness of earth conductor				
f)	Effective covering of junction boxes, panels and other energized wiring places				
g)	Ground fault circuit interrupters provided				
h)	Prevention of tripping hazards maintained				
f)	DCP extinguishers arranged & licensed electrician engaged at site				

Safety walk-through performer (Name & Signature).....

FORMAT NO. : HSE-1 REV 1

(Sheet 5 of 6)

SL. NO.	ITEM	Satisfactory/ Yes	Non satisfactory/ No	Remarks	Action
13.	HANDLING AND STORAGE OF MATERIALS				
a)	Safely stored or stacked				
b)	Passageways clear / free from obstructions				
c)	Fire fighting facility in place				
14.	FLAMMABLE GASES AND LIQUIDS				
a)	Containers clearly identified / protected from fire				
b)	Safe storage & transportation arrangement made				
c)	Fire extinguishers positioned nearby				
d)	Facilities kept away from electric spark, hot spatters & ignition source.				
15.	WORKING AT HEIGHT				
a)	Approved Erection plan and work permit in place				
b)	Safe access, Safe work platform & Safety nets provided				
c)	Life lines, Fall arrester, Full body harness with double lanyards used;				
d)	Health Check record available for workers going up?				
e)	Protective handrails arranged around floor openings				
16.	CONFINED SPACE				
a)	Work Permit obtained from requisite authority				
b)	Test for toxic gas and sufficient availability of oxygen conducted & status				
c)	Supervisor present at site & at least one person outside the confined space for monitoring deputed				
d)	Availability of safe means of entry, exit and ventilation (register for entry & exit maintained)				
e)	Fire extinguisher and first-aid facility ensured				
f)	Lighting provision made by using 24V Lamp				
g)	Proper usage of PPEs ensured				
17.	RADIOGRAPHY				
a)	Proper storage and handling of source as per BARC/ AERB guidelines (authorized radiographer available)				
b)	Work permit obtained				

Safety walk-through performer (Name & Signature).....

FORMAT NO. : HSE-1 REV 1

(Sheet 6 of 6)

SL. NO.	ITEM	Satisfactory/ Yes	Non satisfactory/ No	Remarks	Action
c)	Cordoning of the area done				
d)	Use of appropriate PPE's ensured				
e)	HSE training to workers/supervisors imparted during the fortnight (indicate topic)				
f)	Minimum occupancy of workplace ensured				
18.	HEALTH CHECKS				
a)	All Workers medically examined and found be fit for working at heights (slinging, rigging, painting etc.) in confined space in excavation / trenching in shot blasting				
b)	Availability of First Aid box with contents				
c)	Proper sanitation at site, office and labour camps				
d)	Arrangement of medical facilities.				
e)	Measures for dealing with illness at site & labour camps.				
f)	Availability of Potable drinking water for workmen & staff.				
g)	Provision of crèches for children.				
h)	Stand by vehicle / ambulance available for evacuation of injured				
i)	Adherence to Govt. Guidelines/procedures during epidemic and pandemic (as applicable).				
19.	ENVIRONMENT				
a)	Chemical and Other Effluents properly disposed				
b)	Cleaning liquid of pipes disposed off properly				
c)	Seawater used for hydro-testing disposed off as per agreed procedure				
d)	Lubricant Waste/Engine oils properly disposed				
e)	Waste from Canteen, offices, sanitation etc. disposed properly				
f)	Disposal of surplus earth, stripping materials, Oily rags and combustible materials done properly				
g)	Green belt protection				

Safety walk-through performer (Name & Signature).....

FORMAT NO. : HSE-2 REV 0

(Sheet 1 of 3)

**ACCIDENT REPORT**

(To be submitted by Contractor after every Accident within 24 hours to EIL/ Owner)

Report No.: \_\_\_\_\_ Date: \_\_\_\_\_

Project site: \_\_\_\_\_ Name of work: \_\_\_\_\_

Contractor's name: \_\_\_\_\_ Contractor's Job Engineer (name) \_\_\_\_\_

Non-disabling injury (Non-LTI)	Hospitalized but resumed duty before end of 48 hrs of accident	
Disabling injury (other LTI)	Hospitalized & failed to resume duty within next 48 hrs	
Fatal (LTI):	Death / Expiry	
First Aid case	Resume duty after first aid	

Name of the injured: \_\_\_\_\_ Father's name of victim: \_\_\_\_\_

Sub Contractor's Name: .....

Gate Pass No.: ..... Age: \_\_\_\_\_ Yrs. Victim's medical fitness exam. (Pre-empl.) date: - \_\_\_\_\_

Date & time of Accident / Incident: \_\_\_\_\_

Names of Witnesses: (1) \_\_\_\_\_ (2) \_\_\_\_\_ (3) \_\_\_\_\_

**Profession of victim:**

Bar bender		Carpenter		Meson	
Fitter		Helper		Gas cutter	
Grinder		Welder		Electrician	
Driver		Rigger		M/c.operator	
Engineer		Manager		Other/specify	

**Qualification**

No formal education		Non-Matriculate		Matriculate	
Graduate		Post- grad		Other/specify	

**Job Experience**

NIL		Less than 2 yrs		2-5 yrs	
5-10 yrs		11-15 yrs		15 years and above	

Location where the incident happened: \_\_\_\_\_

\_\_\_\_\_

FORMAT NO. : HSE-2 REV 0

(Sheet 2 of 3)

Activity / Works that were continuing during incident / accident: -

Excavation		Demolition		Concrete carrying	
Concrete pouring		Transportation of materials (manually)		Transportation of materials (mechanically)	
Work on or adjacent to water		Work at height (+2.0 mts)		Scaffold preparation	
Scaffold dismantling		Piling works		Welding	
Grinding		Gas-cutting		Pipe fit-ups & fabrication	
Structural fabrications		Machine works		Hydro-testing works	
Electrical works		Erection activities		Other/specify	

What exactly the victim was doing just before the incident / accident? .....

.....  
.....

Nature of injury:

Bruise or Contusion		Abrasion (superficial wound)		Sprains or strains	
Cut or Laceration		Puncture or Open wound		Burn	
Inhalation of toxic or Poisonous fumes or gases		Absorption		Amputation	
Fracture		Other/specify			

Parts of body involved in incident / accident

Head		Face		Eyes	
Throat		Arm (above wrist)		Hand (including wrist)	
Fingers		Trunk (Abdomen / Back / Chest / Shoulder)		Throat	
Leg (above ankle)		Foot (incl. ankle)		Toes	
Multiple				Other/specify	

Accident type:

Struck against		Struck by		Fall from Elevation	
Fall on same level		caught in		caught under	
caught in between		Rubbed or abraded		Contact with (Electricity)	
Contact with (Temp./ extremes)		Contact with chemicals oils		Vehicle accident	
Other/specify					

FORMAT NO. : HSE-2 REV 0

(Sheet 3 of 3)

**Medical Aid provided:-**(indicate specific aids / treatment etc.)-

.....  
 .....  
 -----

**Actions taken to prevent recurrence of similar incident / accident:**.....

.....  
 .....  
 .....  
 .....  
 .....

**Intimation to local authorities** (Dist. Collector / Local Police Station / ESI authority): Yes / No / NA.

If yes, to whom .....

Safety Officer  
 (Signature and Name)  
 Stamp of Contractor

Site Head / Resident Construction Manager  
 (Signature and Name)

- To : Owner  
 : RCM/Site-in-charge EIL (3 copies)
- Nodal Officer HO through RCM (In case of major accident)
  - Divisional Head (Constn) through RCM
  - Project Manager, EIL, through RCM

FORMAT NO. : HSE-3 REV 0

(Sheet 1 of 5)

**SUPPLEMENTARY ACCIDENT INVESTIGATION REPORT**  
**TICK THE APPROPRIATE ONEAS APPLICABLE (furnish within 72 hours)**

Supplementary to Incident / Accident Report No: \_\_\_\_\_ (Copy enclosed)

Report No.: \_\_\_\_\_ Date: \_\_\_\_\_

Project site: \_\_\_\_\_ Name of work: \_\_\_\_\_

Contractor's name: \_\_\_\_\_ Contractor's Job Engineer (name) \_\_\_\_\_

<b>Non-disabling injury (Non-LTI)</b>	Hospitalized but resumed duty before end of 48 hrs of accident.	
<b>Disabling injury (other LTI)</b>	Hospitalized & failed to resume duty within next 48 hrs.	
<b>Fatal (LTI)</b>	Death / Expiry	
<b>First Aid case</b>	Resume duty after first aid	

Name of the injured: \_\_\_\_\_ Father's name of victim: \_\_\_\_\_

Sub Contractor's Name: .....

Gate Pass No.:..... Age: \_\_\_\_\_ Yrs. Victim's medical fitness exam. (Pre-empl.) date: - \_\_\_\_\_

**Date & time of Accident / Incident:** \_\_\_\_\_

Names of Witnesses: (1) \_\_\_\_\_ (2) \_\_\_\_\_ (3) \_\_\_\_\_

**Profession of victim:**

Bar bender		Carpenter		Meson	
Fitter		Helper		Gas cutter	
Grinder		Welder		Electrician	
Driver		Rigger		M/c. operator	
Engineer		Manager		Other/specify	

**Qualification**

No formal education		Non-Matriculate		Matriculate	
Graduate		Post- grad		Other/specify	

**Job Experience**

NIL		Less than 2 yrs.		2-5 yrs.	
5-10 yrs.		11-15 yrs.		15 years and above	

**Location where the incident happened:** \_\_\_\_\_

\_\_\_\_\_

FORMAT NO. : HSE-3 REV 0

(Sheet 2 of 5)

Activity / Works that were continuing during incident / accident: -

Excavation		Demolition		Concrete carrying	
Concrete pouring		Transportation of materials (manually)		Transportation of materials (mechanically)	
Work on or adjacent to water		Work at height (+2.0 mts)		Scaffold preparation	
Scaffold dismantling		Piling works		Welding	
Grinding		Gas-cutting		Pipe fit-ups & fabrication	
Structural fabrications		Machine works		Hydro-testing works	
Electrical works		Erection activities		Other/specify	

What exactly the victim was doing just before the incident / accident? .....

.....  
.....

Particular of tools & tackles being used and condition of the same after incident/accident:

.....  
.....

Description of Incident/Accident (How the incident was caused) : .....

.....  
.....  
.....

Nature of injury:

Bruise or Contusion		Abrasion (superficial wound)		Sprains or strains	
Cut or Laceration		Puncture or Open wound		Burn	
Inhalation of toxic or Poisonous fumes or gases		Absorption		Amputation	
Fracture		Other/specify			

Parts of body involved in incident / accident

Head		Face		Eyes	
Throat		Arm (above wrist)		Hand (including wrist)	
Fingers		Trunk (Abdomen / Back / Chest / Shoulder)		Throat	
Leg (above ankle)		Foot (incl. ankle)		Toes	
Multiple				Other/specify	

FORMAT NO. : HSE-3 REV 0

(Sheet 3 of 5)

**Accident type:**

Struck against		Struck by		Fall from Elevation	
Fall on same level		caught in		caught under	
caught in between		Rubbed or abraded		Contact with (Electricity)	
Contact with (Temp./ extremes)		Contact with chemicals or oils		Vehicle accident	
Other/specify					

Name & Designation of person who provided First-Aid to the victim: \_\_\_\_\_

Name & Telephone number of Hospital where the victim was treated \_\_\_\_\_

Mode of transport used for transporting victim – Ambulance / Private car / Tempo / Truck / Others

How much time taken to shift the injured person to Hospital \_\_\_\_\_

In case of FATAL incident, indicate clearly the BOCW Registration No. of the victim/Company.....

...

Comments of Medical Practitioner, who treated / attended the victim/injured (attached / described here) \_\_\_\_\_

What actions are taken for investigation of the incident, please indicate clearly – (Video film / Photography / Measurements taken etc. ....)

**Immediate cause** (Please tick the right applicable) –

Hazardous methods or procedures inadequately guarded		Poor housekeeping		Inadequate or improper PPE	
Environmental hazards (excess noise/ space constraint/ inadequate ventilation)		improper illumination/Moving on oval surface		Working on dangerous equipment	

FORMAT NO.: HSE-3 REV 0

(Sheet 4 of 5)

Failure to secure		Horse-play		Failure to use PPE	
Inattention to surroundings		Improper use of hands & body-parts		By-passing safety devices	
Unsafe mixing or placement of tools & tackles		Bypassing standard procedures		Failure in communication	
Operating without authority		Improper use of equipment or tools & tackles		drug or alcoholic influence	
excessive haste		Others(specify)			

**Basic cause**

Over confidence		Impulsiveness		over-exertion	
Faulty judgement or poor understanding		Failing to keep attention constantly		Nervousness & Fear	
Fatigue		Defective vision		Ill health or sickness	
Slow reaction		Others(specify)			

**Root cause**

Inadequate Engg.		Improper Design		Inadequate Planning & organization	
Inadequate knowledge		Inadequate skill		Inadequate training	
Inadequate supervision		Improper work procedure		Inadequate compliance with standard	
Substandard performance		Inadequate maintenance		Improper inspection	
Others(specify)					

Loss of man days and impact on site works, (if any) –

**Remarks from Contractor's Safety Officer/ Engineer –**

Was the victim performing relevant tasks for which he was engaged /employed? Yes / No  
 Was the Supervisor present on work-site during the incident? Yes / No  
 Have the causes of incident rightly identified? Yes / No  
 Cause of Accident was \_\_\_\_\_

FORMAT NO. : HSE-3 REV 0

(Sheet 5 of 5)

Remedial measures recommended by **Safety Officer of Contractor** for avoiding similar incident in future

: .....

.....

.....

.....

.....

.....

.....

**Intimation to local authorities** (Dist. Collector / Local Police Station / ESI authority): Yes / No / NA.

If yes, to whom .....

Safety Officer  
 (Signature and Name)

Site Head / Resident Construction Manager  
 (Signature and Name)  
 Stamp of Contractor

To : Owner  
 : RCM/ Site-in-charge of EIL (3 copies)  
 Nodal Officer HO through RCM (In case of major accident)  
 Divisional Head (Constn.) through RCM  
 Project Manager EIL, through RCM

FORMAT NO. : HSE-4 REV 0

**NEAR MISS INCIDENT/ DANGEROUS OCCURRENCE REPORT PROFORMA**  
(to be submitted within 24 hours)

Report No.: \_\_\_\_\_

Name of Site: \_\_\_\_\_

Date: \_\_\_\_\_

Name of work: \_\_\_\_\_

Contractor: \_\_\_\_\_

Incident reported by :

Date & Time of Incident :

Location :

Brief description of incident

Probable cause of incident

Suggested corrective action

Steps taken to avoid recurrence

Yes

No

Safety Officer

Site Head / Resident Construction Manager

(Signature and Name)

(Signature and Name)

Stamp of Contractor

Note:

- **Near Miss:** Human injury escaped & no damage to property, equipment or interruption to work.
- **Dangerous Occurrence:** Occurrences as mentioned below shall be considered as "Dangerous occurrences"
  - a. collapse or failure of lifting appliances or hoist or conveyors or other similar equipment for handling building or construction material or breakage or failure of rope, chain or loose gears; overturning of cranes used in building or other construction work; falling of objects from height;
  - b. collapse or subsidence of soil, any wall, floor, gallery, roof or any other part of any structure, platform, staging, scaffolding or any means of access including formwork;
  - c. collapse of transmission tower;
  - d. fire and explosion causing damage to property at Construction site.
  - e. spillage or leakage of hazardous substances and damage to their container;
  - f. Collapse, capsizing, toppling or collision of transport equipment;
  - g. Leakage or release of harmful toxic gases at the construction site.

To : Owner

:RCM/Site-in-charge EIL (3 copies)

Divisional Head (Const.) through RCM  
Project Manager EIL, through RCM

} (Applicable for Dangerous Occurrence only)

FORMAT NO. : HSE-5 REV 0  
MONTHLY HEALTH, SAFETY & ENVIRONMENTAL (HSE) REPORT  
(To be submitted by each Contractor)

Actual work start Date: \_\_\_\_\_ For the Month of: \_\_\_\_\_

Project: \_\_\_\_\_ Report No: \_\_\_\_\_

Name of the Contractor: \_\_\_\_\_ Status as on: \_\_\_\_\_

Name of Work: \_\_\_\_\_ Job No : \_\_\_\_\_

(Contractor in consultation with EIL shall generate the reports through web based package (www3.eil.co.in/eilhse)only.

ITEM	UPTO PREVIOUS MONTH	THIS MONTH	CUMULATIVE
1) Average number of Staff & Workmen (average daily headcount, not man days)			
2) Total Man-hours worked			
3) Number of site personnel undergone HSE Induction			
4) Number of HSE meetings organized at site			
5) Number of HSE awareness programmes conducted at site			
6) Number of Tool Box Talks conducted			
7) Number of Loss Time Injuries (LTI)	Fatalities		
	Other LTI		
8) Number of Non disabling injury (Non-LTI)			
9) Number of First Aid Cases			
10) Number of Near Miss Incidents			
11) Number of Dangerous Occurrences			
12) No. of unsafe acts/ practices detected			
13) No. of disciplinary actions taken against staff/ workmen			
14) Man-days lost due to injury			
15) LTI Free man-hours i.e. LTI free man-hours counted from the Last LTI (enter date: .....)			
16) Frequency Rate (No. of reportable LTI per 10lacs man-hours worked)			
17) Severity Rate (No. of man days lost due to LTI per 10lacs man-hours worked)			
18) No. of activities for which HIRAC Completed			
19) No. of incentives/ awards given			
20) No. of occasions on which penalty imposed by EIL/ Owner			
21) No. of Audits conducted			
22) No. of pending NCs in above Audits			
23) Compensation cases raised with Insurance			
24) Compensation cases resolved and paid to workmen			
25) No of Vehicular Accident cases			
26) No of fire/Explosion cases			
27) Whether workmen compensation policy taken		Yes	No
28) Whether workmen compensation policy is valid		Yes	No
29) Whether workmen registered under ESI Act, as applicable		Yes	No
30) Whether HIRAC Register prepared and updated		Yes	No
31) Whether Environment Aspect Impact Register prepared and updated		Yes	No
32) Whether Legal Register prepared and updated		Yes	No
Remarks, if any			

Date:

Prepared by Safety Officer Approved by Site Head / Resident Construction Manager  
(Signature and Name)(Signature and Name)

To: -  
- RCM EIL

FORMAT NO. : HSE-6 REV 1

**PERMIT FOR WORKING AT HEIGHTS (ABOVE 2.0 METER)**

(In duplicate to be issued daily for site and for office)

Permit No..... Name of Main Contractor.....  
 Name of work executing agency / sub agency / vendor:.....  
 Date..... Exact Location of work.....  
 Nature of work .....Duration of work (from) ..... (to) .....  
 Number of workers covered within this permit.....  
 (List enclosed with name & gate pass numbers.)

Sl. No.	Items / Subjects	Status of compliance (Yes / No)
1	Work areas / Equipment's inspected	
2	Work area cordoned off	
3	Adequate lighting is provided	
4	Precautions against public traffic taken	
5	Concerned persons in & around have been alerted & cautioned	
6	Hazards / risks involved in routine / non-routine task assessed and control measures have been implemented at specific task	
7	ELCB provided for electrical connection & found working	
8	Ladder safely attached / fixed	
9	Scaffoldings are checked and TAGs are found used correctly	
10	Working platforms are provided and are found sound /safe for use	
11	Safe access & egress arrangements (e.g. ladders, fall arresters, life-lines etc.) are satisfactorily incorporated	
12	a. Openings on platform / floors are effectively cordoned / covered	
	b. Safety Nets are provided wherever required	
13	Use of following safety gadgets by people working at area under this permit, is checked and found satisfactory -	
	Safety helmet	
	Safety harness (full body) with double lanyard	
	Safety Shoes	
	Safety gloves	
14	Housekeeping of work area found satisfactorily tidy / clean & clear	
15	Adequate measures have been taken for works being continued at the ground level, when simultaneous works are permitted overhead at that very location.	
16	Materials are not thrown from heights on to ground	
17	Medical examination of workers are made & found satisfactory	
18	Responsible job engineer / supervisor found physically present at work spot for overall administration of work as well as safety of people.	

Above items have been checked & compliance has been found in place. Hence work is permitted to start / continue at the above-mentioned location. Work shall not start till identified lapses are rectified.

Additional Precautions, if any .....

Work Permit Receiver                      Verification By                      Work Permit issuer  
 Contractor Job Supervisor              Contractor Safety Officer              Contractor Engineer/RCM

**AT THE END OF THE DAY/WORK:**

All works at height are completed & workmen have returned safely from work location at (time)..... (date).....

(Sig. Contractor Engineer)

FORMAT NO. : HSE-7 REV 1

**CONFINED SPACE ENTRY PERMIT**

Project site \_\_\_\_\_ Sr. No. \_\_\_\_\_  
 Name of the work \_\_\_\_\_ Date \_\_\_\_\_  
 Name of Contractor \_\_\_\_\_ Nature of work \_\_\_\_\_  
 Exact location of work \_\_\_\_\_

Safety Requirements POSITIVE ISOLATION OF THE VESSEL IS MANDATORY								
<b>(A) Has the equipment been ?</b>								
Y NR				Y NR				Y NR
<input type="checkbox"/> <input type="checkbox"/>	Isolated from power/steam/air	<input type="checkbox"/> <input type="checkbox"/>	water flushed &/or steamed	<input type="checkbox"/> <input type="checkbox"/>	radiation sources removed	<input type="checkbox"/> <input type="checkbox"/>		
<input type="checkbox"/> <input type="checkbox"/>	isolated from liquid or gases	<input type="checkbox"/> <input type="checkbox"/>	Man ways open & ventilated	<input type="checkbox"/> <input type="checkbox"/>	proper lighting provided	<input type="checkbox"/> <input type="checkbox"/>		
<input type="checkbox"/> <input type="checkbox"/>	depressurized &/or drained	<input type="checkbox"/> <input type="checkbox"/>	cont. inert gas flow arranged	<input type="checkbox"/> <input type="checkbox"/>		<input type="checkbox"/> <input type="checkbox"/>		
<input type="checkbox"/> <input type="checkbox"/>	blanked/ blinded/ disconnected	<input type="checkbox"/> <input type="checkbox"/>	adequately cooled	<input type="checkbox"/> <input type="checkbox"/>		<input type="checkbox"/> <input type="checkbox"/>		
<b>(B) Expected Residual Hazards</b>								
<input type="checkbox"/> <input type="checkbox"/>	lack of O <sub>2</sub>	<input type="checkbox"/> <input type="checkbox"/>	combustible gas/ liquid	<input type="checkbox"/> <input type="checkbox"/>	H <sub>2</sub> S / toxic gases	<input type="checkbox"/> <input type="checkbox"/>		
<input type="checkbox"/> <input type="checkbox"/>	corrosive chemicals	<input type="checkbox"/> <input type="checkbox"/>	pyrophoric iron / scales	<input type="checkbox"/> <input type="checkbox"/>	electricity / static	<input type="checkbox"/> <input type="checkbox"/>		
<input type="checkbox"/> <input type="checkbox"/>	heat/ steam / frost	<input type="checkbox"/> <input type="checkbox"/>	high humidity	<input type="checkbox"/> <input type="checkbox"/>	ionizing radiation	<input type="checkbox"/> <input type="checkbox"/>		
<input type="checkbox"/> <input type="checkbox"/>		<input type="checkbox"/> <input type="checkbox"/>		<input type="checkbox"/> <input type="checkbox"/>		<input type="checkbox"/> <input type="checkbox"/>		
<b>(C) Protection Measures</b>								
<input type="checkbox"/> <input type="checkbox"/>	gloves	<input type="checkbox"/> <input type="checkbox"/>	ear plug / muff	<input type="checkbox"/> <input type="checkbox"/>	goggles / face shield	<input type="checkbox"/> <input type="checkbox"/>		
<input type="checkbox"/> <input type="checkbox"/>	protective clothing	<input type="checkbox"/> <input type="checkbox"/>	dust / gas / air line mask	<input type="checkbox"/> <input type="checkbox"/>	personal gas alarm	<input type="checkbox"/> <input type="checkbox"/>		
<input type="checkbox"/> <input type="checkbox"/>	grounded air duct/blower /AC	<input type="checkbox"/> <input type="checkbox"/>	attendant with SCBA/air mask	<input type="checkbox"/> <input type="checkbox"/>	rescue equipment/team	<input type="checkbox"/> <input type="checkbox"/>		
<input type="checkbox"/> <input type="checkbox"/>	Fire fighting arrangements	<input type="checkbox"/> <input type="checkbox"/>	safety harness & lifeline	<input type="checkbox"/> <input type="checkbox"/>	communication equipment	<input type="checkbox"/> <input type="checkbox"/>		
<input type="checkbox"/> <input type="checkbox"/>		<input type="checkbox"/> <input type="checkbox"/>		<input type="checkbox"/> <input type="checkbox"/>		<input type="checkbox"/> <input type="checkbox"/>		
Authorization / Renewal (It is safe to enter the confined space)								
	No. of persons allowed	Name of persons allowed	Signature			Time		Signature
			Work Permit Receiver(Contractor Supervisor)	Verification by Contractor Safety officer	Work permit issuer Contractor Engineer/RCM	From	To	Workman
<b>Permit Closure :</b>								
(A) Entry <input type="checkbox"/> was closed <input type="checkbox"/> stopped <input type="checkbox"/> will continue on ...								
(B) <input type="checkbox"/> Site left in a safe condition <input type="checkbox"/> Housekeeping done								
(C) Multi lock <input type="checkbox"/> removed <input type="checkbox"/> key transferred								
<input type="checkbox"/> Ensured all men have come out <input type="checkbox"/> Man-ways barricaded								
Remarks, if any:								

FORMAT NO. : HSE-8 REV 0

**RADIATION WORK PERMIT**

Project : Sr. No. :  
 Name of the work : Date :  
 Name of site contractor : Job No.:

Location of work :

Source strength :

Cordoned distance (m) :

Name of Radiography agency : Approved by Owner/EIL

No. of workers engaged :  
 (List enclosed with name & gate pass numbers.)

The following items have been checked & compliance shall be ensured during currency of the permit:

S. No.	Item description	Done
	Safety regulations as per BARC/AERB ensured while source in use/in transit & during storage	<input type="checkbox"/>
	Area cordoned off / safe working platform provided	<input type="checkbox"/>
	Lighting arrangements for working during nights ensured	<input type="checkbox"/>
	Warning signs/ flash lights installed	<input type="checkbox"/>
	Cold work permit taken (if applicable)	<input type="checkbox"/>
	PPEs like film badges, dosimeters used	<input type="checkbox"/>

Additional precautions, if any \_\_\_\_\_

(Radiography Agency's BARC/AERB authorized Supervisor)

Permission is granted.

Permit is valid from \_\_\_\_\_ AM/PM \_\_\_\_\_ Date to \_\_\_\_\_ AM/PM \_\_\_\_\_  
 Date

(Signature of permit issuing authority-RCM of contractor)

Name : Designation: Date:

Permit renewal:

Permit extended up to		Additional precautions required, if any	Sign of issuing authority with date (of site contractor)
Date	Time		

Work completed/ stopped/ area cleared at \_\_\_\_\_ Hrs of Date \_\_\_\_\_

(Sign. of permit issuing authority)  
 Name & Signature of site contractor:

FORMAT NO. : HSE-9 REV 1  
DEMOLISHING/DISMANTLING WORK PERMIT

Project : Sr.No. :  
Name of the work : Date :  
Name of contractor : Job No. :

Name of sub-contractor : No. of workers to be engaged:  
(List enclosed with name & gate pass numbers.)

Line No./ Equipment No./ Structure to be dismantled :

Location details of dismantling/ demolition with sketch : (clearly indicate the area)

The following items have been checked & compliance shall be ensured during currency of the permit:

S. No.	Item description	Done	Not Applicable
	Services like power, gas supply, water, etc. disconnected	<input type="checkbox"/>	<input type="checkbox"/>
	Dismantling/ Demolishing method reviewed & approved	<input type="checkbox"/>	<input type="checkbox"/>
	Usage of appropriate PPEs ensured	<input type="checkbox"/>	<input type="checkbox"/>
	Precautions taken for neighboring structures	<input type="checkbox"/>	<input type="checkbox"/>
	First-Aid arrangements made	<input type="checkbox"/>	<input type="checkbox"/>
	Fire fighting arrangements ensured	<input type="checkbox"/>	<input type="checkbox"/>
	Precautions taken for blasting	<input type="checkbox"/>	<input type="checkbox"/>

Work Permit Receiver  
(Contractor's Supervisor/Engineer)

Verification by Contractor  
(Contractor's Safety Officer)

Permission is granted.

(Work Permit issuer-Client)

Name :  
Date :

Completion report:

Dismantling/ Demolishing is completed on \_\_\_\_\_ Date at \_\_\_\_\_ Hrs.

Materials/ debris transported to identified location  Tagging completed (as applicable)

Services like power, gas supply, water, etc. restored

(Permit issuing authority-Client)

CONTRACTOR'S NAME

FORMAT NO. : HSE-10 REV 0

**DAILY SAFETY CHECKLIST**

(To make use of before start of day's work)

Project : Sr.No. :  
Name of the work : Date :  
Name of contractor : Job No. :

Description of Job decided to perform : -

- Use of PPE / Safety Gadgets

Sl. No	PPEs	Compliance (Yes / No)	Sl. No	PPEs	Compliance (Yes / No)
1	Safety Helmets		6	Face Shield	
2	Safety Shoes		7	Full body harness	
3	Hand Gloves		8	Fall Arrest System	
4	Dust Musk		9	Safety net	
5	Safety Goggles		10	Horizontal life-line made of steel wire, (dia not less than 8.0 mm.)	

(Serial No. 1 & 2 are compulsory for everyone. Specify & ensure use of other safety gadgets as required for the job)

- Identify following important unsafe conditions: -

Sl. No	Conditions	Yes / No
1	Access to work site / emergency escape clear	
2	Soil / Loose earth kept away from excavated pit / slope / ladder provided	
3	Electrical wire / welding lead lying entangled on ground / welding m/c. booth accessible	
4	Elevated work platform / open ends are protected	
5	Ground area cordoned off before lifting works or erection at height / ground area checked & cordoned-off before start of height works	
6	Structural members / erected pipes / wooden boards/pieces etc. are safely anchored at heights and are not likely to fall down on people when working beneath	
7	Ladders tied-up on tall steel structures, long before are removed to get rid of their use	
8	Any Other	

- Indicate actions taken, if status of any of the above items is found "No"  
.....
- Specific Safety guidelines / precautions, if any (communicated thro' TBT)  
.....
- Above conditions and PPE compliances are checked by undersigned and correct status are indicated after verification

Prepared by  
Contractor Site Engineer

Verification By  
Contractor Safety Officer

FORMAT NO. : HSE-11 REV 0

(Sheet 1 of 2)

HOUSEKEEPING ASSESSMENT & COMPLIANCE

Project : Sr.No. :  
Name of the work : Date :  
Name of contractor : Job No. :  
Name of contractor : Fortnightly

Sl. No.	Subjects of Review	Satisfactory/ Yes	Non satisfactory/No	Remarks	Action
1.	Cleanliness at the Main entry / access of site				
2.	Ground condition / floor areas free from water-logging / oil spillage				
3.	Ground & elevated floors free from rubbish / wastes / accumulated debris / scraps.				
4.	Manholes / openings are covered / fenced				
5.	Trenches are barricaded / walkways are in place				
6.	Drains are cleaned / not choked / not occupied by dumped materials				
7.	Sufficient CAUTION boards / instructions displayed				
8.	Construction machinery are maintained & parked in orderly manner.				
9.	Movement of site people are not obstructed because of dumping / storing of construction materials				
10.	Access / egress to Electrical Distribution Boards / Panels clear from wires / cables / earth-strips etc.				
11.	Electrical panel rooms / sheds / MCC / Control rooms / Substations etc. are clean & tidy and not used for storing dress / clothes, tiffin-box or bicycles.				
12.	Passage behind Elec. panels are free for access				
13.	Fire extinguishers / fire-buckets are accessible without any difficulty.				
14.	Stair-steps, platforms & landings are clear & tidy				
15.	Sheds / rooms & work areas have got sufficient illumination as well as ventilation				
16.	Cables / Wires / welding leads are routed / hanged appropriately & are not creating unsafe condition.				
17.	Stacking / storing of insulation materials or their packing.				
18.	Removal or cleanliness of left-over sand, concrete, brick-bats, insulation-materials, excess earth, wastes etc.				
19.	Storing / stacking of sand, metal chips, re-bars, steel pipes, valves, fittings etc.				
20.	One escape route at ground & minimum two escape routes at elevation available,				

FORMAT NO. : HSE-11 REV 0

(Sheet 2 of 2)

Sl. No.	Subjects of Review	Satisfactory/ Yes	Non satisfactory/No	Remarks	Action
21.	Captions / Posters / Slogans on various safety instructions are displayed legibly in local language				
22.	Cable trenches are water-free or regular arrangement for taking out accumulated water exists.				
23.	Windows of rooms / offices are regularly cleaned				
24.	Facilities for cycle sheds, drinking water, washing, rest-rooms etc. are maintained in tidy manner.				
25.	Toilet, Urinals, Canteen / kitchen / pantry etc. are maintained & free from obnoxious smell.				
26.	Construction tools / tackles are stored systematically - the items are tagged / tested / certified by competent third party.				
27.	Sufficient numbers of Dust-bins / Waste-bins found at site and are regularly emptied.				

Additional remarks, if any -

.....  
.....  
.....

Inspected by  
Contractor Engineer

Verification By  
Contractor Safety Officer

FORMAT NO. : HSE-12 REV 0

**INSPECTION OF TEMPORARY ELECTRICAL BOOTH / INSTALLATION**

Project : Sr.No. :  
Name of the work : Date :  
Name of contractor : Job No. :  
Sub Station No./Booth No : Location:

SL NO	SUBJECTS	OBSERVATION (YES /NO)	ACTION TAKEN
1	Switchboards installed properly are in order and protected from rain & water-logging.		
2	Adequate illumination provided for switchboard operation during night hours & the lamps are protected from direct human contact.		
3	Voltage ratings, DANGER signs, Shock-Treatment-Chart displayed in the installation / booth		
4	Fire extinguisher (DCP or CO <sub>2</sub> ) & Sand Bucket kept in close vicinity of Switchboards		
5	Valid License & Competent Electrician / Wireman available & name/ license no. displayed at booth / installation.		
6	General housekeeping in & around booth / installation found in order.		
7	Cable-route-markers for U/G cables provided.		
8	Monthly inspection report of Electrical hand tools available in booth / installation.		
9	Electrical Panel door to be in closed condition and Insulated Mat to be provided in front of panel.		
10	Rubber hand gloves available/ used by Electricians		
11	Availability of CAUTION boards for shutdown & / or repairing works.		
12	All incoming & outgoing feeders have proper MCCB / HRC fuses / Switches.		
13	Switchboards "earthed" at two distinctly isolated locations.		
14	Switchboards have adequate operating space at the front face & at the rear face too.		
15	All connections provided through 30mA ELCB.		
16	Testing records of all ELCBs available at site		
17	Only industrial type plugs & sockets are used.		
18	Temporary connections are 3-core double insulated & free from cuts & joints and 3 <sup>rd</sup> core is earthed at both ends		
19	Socket boards are properly mounted on stand & protected from water ingress.		
20	Electrical equipments operating above 250V have two earthing / double earthing.		
21	All incoming / outgoing cables are properly glanded& terminated with "lugs".		
22	Switch-boards are of industrial variety / type.		
23	Sketch for installation / connection (SLD) made & pasted& other safety labels/display boards		
24	Labeling of incoming / outgoing feeders made.		
25	All hand lamps are protected from direct contact.		
26	All electrical cable / joints are in safe condition		

Inspected by  
Contractor Engineer

Verification By  
Contractor Safety Officer

FORMAT NO. : HSE-13 REV 0

(Sheet 1 of 2)

INSPECTION FOR SCAFFOLDING

Project : Sr.No. :  
Name of the work : Date :  
Name of contractor : Job No. :

Sl. No	Description	Yes	No	N.A.	Actions taken
1	Whether work permit is obtained to take up work at height above 1.5 Mts?				
2	Whether atmospheric condition is "stormy" or "raining" and works at heights have been permitted?				
3	Whether steel pipes scaffoldings are used for units /off-site areas?				
4	Whether scaffolding has been erected on rigid/firm/leveled surfaces / ground? Whether "foot-seals" or "base-plates" are used beneath the up-rights (vertical steel pipes)				
5	Whether scaffold construction is as per IS specification with toe-board and hand-rails (top-rail as well as mid-rail)?				
6	Whether distance between two successive up-rights are less than 2.5 Mts (height of scaffold & load carrying capacity governs the distance between two uprights)				
7	Whether all uprights are extended at least 900 mm above the top most working platform (to enable fitting of handrails)?				
8	Whether vertical distance of two successive ledgers is satisfactory? (varying between 1.3 Mts. To 2.1 Mts)				
9	Whether the peripheral areas of working at height are cordoned-off? (for avoiding accident to people arising out of dropped / deflected materials)				
10	Whether platform is provided? Is it safely approachable?				
11	Whether end of scaffold platform / board are extended beyond transoms? (125mm to 150 mm)				
12	Whether CE / IS approved quality and worthy conditioned full-body safety harness (with double lanyard & karabiners) are used while working at heights?				
13	Whether life-line of safety harness is anchored to an independent secured support capable of withstanding load of a falling person?				
14	Whether the area around the scaffold is cordoned off to prohibit the entry of unauthorized person / vehicle?				
15	Whether clamps used are of good condition, of adequate strength and free from defects?				
16	Whether ladder is placed at secured and leveled surface?				
17	Whether water-pass and oil-spills are avoided around the scaffold structure?				
18	Whether ladder is extended 1.5mts. above the landing point at height?				
19	Whether more than one access/egress provided to the scaffold?				
20	Whether ladder used are of adequate length and overlapping of short ladders avoided?				
21	Whether metallic ladders are placed much away from near-by electrical transmission line?				
22	Whether rungs of ladder are inspected and found in good order?				
23	Whether fall-arresters provided on both the access/egress routes?				
24	Whether diagonal (cross) bracings are provided at regular interval on the scaffold?				
25	Whether working platform on the scaffold has been made free from "jolt" or "gap"?				
26	Whether tools or materials are removed after completion of the day's job at heights?				
27	Whether a valid Permit for Work (PFW) is obtained before taking up work over asbestos or fragile roof?				
28	Whether sufficient precaution is taken while working on fragile roof?				

FORMAT NO. : HSE-13 REV 0

(Sheet 2 of 2)

Sl. No	Description	Yes	No	N. A	Actions taken
29	Whether provision is made to arrange duck ladder, crawling board for working on fragile roof?				
30	Whether scaffold has been inspected by qualified civil engineers prior to their use?				
31	Whether the scaffolding has been designed for the load to be borne by the same?				
32	Whether the erection and dismantling of the scaffolding is being done by trained persons and under adequate supervision?				
33	Whether safety net with proper working arrangement and life-line has been provided?				
34	Whether TAGS (Green for acceptable and Red for incomplete/unsafe scaffolds) are used on scaffolds?				
35	Whether sufficient illumination is provided in and around the scaffold and access?				
36	Whether emergency rescue / response arrangements are made in place				

Inspected by  
Contractor Engineer

Verification By  
Contractor Safety Officer

FORMAT NO. : HSE-14 REV 1

(sheet 1 of 2)

**PERMIT FOR ERECTION / MODIFICATION & DISMANTLING OF SCAFFOLDING**

Project : Sr.No. :  
Name of the work : Date :  
Name of contractor : Job No. :  
Nature of activities : Duration: From.....To.....

SL. No.	SUBJECTS / ITEMS	DONE	NOT DONE	REMARKS
1	Specific task of Erection / Modification / Dismantling of scaffolds, identified & TAGGED accordingly (before as well as after carrying-out jobs).			
2	People engaged in doing the job are identified & are certified by Job Engineer of Main Contractor as experienced / trained.			Names to be noted
3	Concerned persons are alerted by the Job Engineer of Main Contractor in connection with possible hazards & what the workmen MUST do / MUST not do.			
4	Verification by Job Engineer of Main Contractor made for confirming that all persons permitted to carry-out the jobs are making use of Helmet, Safety Shoes, Goggles, Gloves & Double lanyard safety harness and other relevant PPEs.			
5	Area of work is effectively cordoned-off / barricaded / illuminated.			
6	For taking-up / lowering down Scaffolding members / clamps / couplings etc. appropriate ropes / pulleys/ chains etc. have been arranged for use (not to throw any item) & the same have been verified as "fit for purpose".			
7	Items / members of scaffold, being lowered are removed from the area & stacked correctly.			
8	Ropes, chains, pulley blocks etc. being used for lifting or lowering scaffold items, are inspected by the Job Engineer & their certifications as well as physical conditions have been found O.K. before signing this PERMIT.			
9	Safety Net / Life-line / Fall Arresters etc. are arranged in position and Job Engineer has found working conditions favorable for activities to start.			
10	Scaffold erection or dismantling tasks are being supervised by Experienced Engineer / Competent person.			
11	Only competent & experienced people have been selected / engaged in Scaffolding erection, modification or dismantling tasks.			
12	Adequate & effective actions for traffic and movement of people around the cordoned-off area taken to avoid inadvertent incident			
13	Working platforms are protected with handrails & toe-boards.			
14	Access & Exit (for reach & escape) are safe for use by people.			
15	Tools, tackles to be used for above jobs are verified by job Engineers of Main contractor as genuinely good and tied-up at height (to prevent their fall).			
16	Site important Telephone Nos. are made known to everyone			
17	SOP (Safe Operating Procedure) for the specific task is made & followed too.			
18	Emergency vehicle has been arranged at work locations.			

- This permit for work shall be available at specific work location all the time.
- After completion of work, permit shall be returned to safety cell of main contractor, without fail.
- This Permit shall be issued maximum upto (Monday to Sunday).
- Additional Precautions, if any

.....  
 • **ACCORD OF PERMISSION** (to be ticked) - YES ( ) / NO ( )  
 Work Permit Receiver Verification By Work Permit issuer Contractor Job Supervisor  
 Contractor Safety Officer Contractor Engineer/RCM

FORMAT NO. : HSE-14 REV 1

(sheet 2 of 2)

Everyday Site working conditions & performance of workmen shall be assessed / checked by Contractor Site Engr. and Safety Officer shall verify the same.

	Name / Sign.	MONDAY	TUESDAY	WEDNESDAY	THURSDAY	FRIDAY	SATURDAY	SUNDAY
Site Engr.								
Safety Off.								

FORMAT NO. : HSE-15 REV 1

**PERMIT FOR HEAVY LIFT/CRITICAL ERECTION**

Project : Sr. No. :  
 Name of the work : Date :  
 Name of contractor : Job No. :  
 Nature of activities : Duration: From..... To.....  
 Location of work : Name /Type of crane :  
 Equipment/Structure to be erected: Wt. of equipment/ structure to be erected

SL. NO.	Description of Item	COMPLIANCE STATUS			Remarks
		Yes	No	Not applicable	
1)	Is the crane type suitable for lift or as per erection procedure?				
2)	Is the crane have the correct number of counterweights fitted?				
3)	Availability of Load Certification of crane from authorized agency.				
4)	Is the load chart of crane available in crane cabin/or with Crane operator?				
5)	Is the device to check the Wind speed in crane is working? Is the safety features in crane are working?				
6)	Availability of Load certification of slings and other accessories from authorized agency				
7)	Availability of Licensee/certificate for crane operator from authorized agency.				
8)	Availability of approved HIRAC for the subject activities.				
9)	Availability of approved erection/rigging procedures.				
10)	Availability of temporary gratings/ platforms for critical lifting(as applicable)				
11)	Tool Box conducted before erection?				
12)	Has the area been cordoned off?				
13)	Are the authorized persons during erection are identified?				
14)	Does each person identified for erection understand their roles and responsibilities?				
15)	Is the ground on which crane will rest or outrigger support are correct?				
16)	Is hard stand requirement (if any) complied?				
17)	Is the communication system (viz walkie-talkies, etc. are working properly?				
18)	If more than one crane is lifting the load, is an Intermediate rigger will supervise the lift?				
19)	If there is other obstruction within the operating radius of the crane, have correct precautions been taken to prevent collision?				
20)	All the persons are wearing the requisite PPE?				

Work Permit Receiver : Verification By : Work Permit issuer Contractor Job Supervisor  
 Contractor Safety Officer : Contractor Engineer/RCM



FORMAT NO. : HSE-17 REV 1

PERMIT FOR EXCAVATION (depth 2m and above)

(Sheet 1 of 2)

Project : Sr.No. :  
Name of the work : Date :  
Name of contractor : Job No. :  
Job Description : Location :  
Size of excavation :

SL. NO.	Description of Item	COMPLIANCE STATUS			Remarks
		Yes	No	Not applicable	
1)	Suitable and sufficient risk assessments and method statements has been carried to ensure that the work shall be undertaken in accordance with specification and standard.				
2)	Are plans/details of underground services available and the same has been reviewed?				
3)	Has survey done to locate the services/obstacles etc.				
4)	Has the live services (electrical, water line, air line, telephone line, etc)has been disabled for carrying out the job.				
5)	Is adequate barriers/fences to protect the excavation are in place?				
6)	Is Adequate warning signs are in place?				
7)	Is Assessment of ground conditions done and remedial action(if any) taken?				
8)	Safe access / egress (e.g. ramp / steps / ladders etc.) provided for site workmen & supervisors.				
9)	Is the excavation work being undertaken in proximity of structure, etc. ?If Yes, it's effect is considered?				
10)	Availability of competent person for supervising the excavation work?				
11)	Adequate safe arrangement to prevent collapse of edges (e.g. shoring / strutting / benching / sloping etc.) made at site.				
12)	Hard barricades (at least 1.0M away from edge & for excavation near site access roads) with warning signs/caution boards are provided				
13)	Accumulation / passage-ways of water at periphery of excavation / trench stopped/ restricted.				
14)	Is the equipment being used for excavation has been checked for adequacy and is in good working condition having all the safety features?				
15)	Age & fitness of workmen ensured by medical test before engagement in job ?				
16)	Arrangement of Monitoring of possible oxygen deficiency or obnoxious gases done & action taken?				

PERMIT GRANTED - Yes / No

(List enclosed with name & gate pass numbers.)

Name & Signature of Site Engr.

Name & Signature of Area – In charge/RCM of

Contractor (Receiver)

Contractor (Issuer)

Verification by Contractor Safety Officer

FORMAT NO. : HSE-17 REV 1

**PERMIT FOR EXCAVATION**

(Sheet 2 of 2)

**NOTES: -**

1. Slopes or benches for excavation beyond 2.0M depth shall be designed & approved by Contractor's site head.
2. Excavated earth to be kept at least 1.5M away from edges
3. Safety helmets, Safety shoes or gum-boots, gloves, goggles, Face shield, Safety Harness shall be essential PPEs.
4. Permit shall be made in **duplicate** and original shall be available at site of work.
5. Permit shall be issued for maximum **one week** only (Monday to Sunday)
6. After completion of works, permit shall be closed & preserved for record purpose

**GRANT OF PERMIT AND EXTENSIONS**

Sl. No.	Validity period From ____ To ____	Working Time From ____ To ____	Receiver (site Engr. of Main Contractor)	Issuer(Area In charge/RCM of Main Contractor)	Review by EIL / Owner (Remarks with date
1.					
2.					
3.					
4.					
5.					
6.					
7.					

Additional safety instructions if any: -

- 1.
- 2.
- 3.

FORMAT NO. : HSE-18 REV 0

(Sheet 1 of 2)

**IDENTIFICATION OF ENVIRONMENTAL ASPECTS, IMPACT ASSESSMENT AND CONTROL MEASURES**

S.No	Activity	Environmental Aspect	N/A/E	Environment Impact	Control Measures	Consequences						Risk Level	Significant	Gaps/ Recommendations
						A	B	C	D	E	F	G	Yes/No	

(Sheet 2 of 2)

INITIAL ENVIRONMENT REVIEW TECHNIQUE

Environmental Impacts	AP = Air Pollution	WP = Water Pollution	LC = Land Contamination	DNR = Depletion of Natural Resources	NP = Noise Pollution
-----------------------	--------------------	-------------------------	-------------------------	---	----------------------

Scale	Quantity (A)	Occurrence (B)	Severity of Impact (C)	Detection (D)	Control (E)	Legal and other requirements (F)
1	Negligible	Very Rare	Negligible visual impact	Immediately	Available & effective at place	In compliance or not applicable
2	Low	Once a month or less	Causes Discomfort or Nuisance	Within 1 hour	Has in-built Secondary control	
3	Moderate	Once a day	Resource Depletion	Within 8 hours	Needs human Intervention	
4	High	Several times a Day	Affects Aquatic Life, flora, fauna or global issue	Within 24 hours	Mechanism in place but not reliable	
5	Excessive	Continuous	Human health effect	More than 24 hours	Absent or no effective control	Not in compliance

Risk Level - G : A x B x C x D x E x F

Aspects with score of **100 and above** are considered as significant.  
Also, Irrespective of the score, all legal noncompliance's to be considered as significant

Condition	
N	NORMAL
A	ABNORMAL
E	EMERGENCY

FORMAT NO. : HSE-19 REV 0 HIRAC

Risk Identification						Desired Controls & Existing Gaps, If Any		Risk Assessment				Recommended Control Actions To Reduce The Risk Level	Action By	Remarks
SN	Activity	Activity Type (R/NR)	Hazards	Condition(N/AN/E)	Associated Risk	Desired Control Measures	Gaps If Any	Probability(P)	Impact (I)	Risk R= P*I	Risk Classification			

**Likelihood** – Possibility of occurrence of risks based on present gaps (technological / operational / competence / measurement and monitoring);

**UL:** Unlikely, **L:** Likely, **VL:** Very Likely, **FR:** Frequent, **C:** Continuous

**Impact** –

**SI:** Slight Injury, **MI:** Minor Injury, **MJ:** Major Injury, **SF:** Single Fatality, **MF:** Multiple Fatalities

**Level of consequence** – Refer Guidance criteria for this i.e. possible degree of damage;

**Condition-** **N:** Normal, **AN:** Abnormal, **E:**Emergency

**Activity Type:** **R-** Routine, **NR-** Non Routine

**RISK** –

**L:** Low Risk, **M:** Moderate Risk, **H:** High Risk

FORMAT NO.: HSE-20 REV 0

### Inspection of Tower Crane

Name of Contractor:

Project:

Name of Work:

Job No:

Vehicle Identification/Registration No:

Date:

Sr. No.	Description	Observation	Remarks & Suggestions
1	Serial number plate & SWL marking		
2	Valid TPI Certificate		
3	Valid Insurance		
4	Safe access and egress are provided to the crane operator.		
5	Front glass of Operator cabin		
6	Operator crane cabin is provided with a locking mechanism so as to prevent unauthorised entry.		
7	A safety bar is fitted across the operator's cabin window where there is likelihood of the operator falling through it.		
8	Manufacturer Operating Manual and Maintenance Manual are made available.		
9	An updated Operation and Maintenance log book is available in the operator cabin.		
10	All mounting bolts are in good condition.		
11	Load chart provided		
12	SLI available		
13	Crane hooks have got smooth surface and no dent		
14	Hook-latch / Dog-clamp in hook is effective		
15	Over hoist limit switch		
16	Double body earthing of Tower Crane		
17	Jib angle indicator is provided (For Luffing Jib Tower Crane).		
18	Emergency stop button, which will terminate the operation of the crane engine, is installed in the operator cabin and correctly identified.		
19	Effective braking mechanisms for Hoisting, Derricking, Slewing, Trolley Travelling maintained:		
20	Trolley Travelling limiter to prevent over-travelling of trolley is functional.		
21	Limit switches to prevent over-derricking and over-lowering of jib (For Luffing Jib Tower Crane) is functional.		
22	Slewing limiter to restrict slewing of crane is functional.		
23	Over load Limiter to prevent overloading of crane is functional.		
24	Load Moment Limiter to prevent over-turning moment is functional.		
25	Anti-collision devices are tested to stop the tower crane's operation such that the crane-to-crane interference must be maintained at not less than 3 m.		
26	Condition of boom		
27	Counter weight placement and pins		
28	Winches, pulleys and wire ropes are in good working condition.		
29	Colour coding		
30	Leakage in hydraulic cylinder		



31	Fire Extinguisher		
32	Tower crane is adequately grounded or protected against lightning.		
33	Wind anemometer is installed and is in good working condition.		
34	Aviation lamp is functional (Reqd. for 30mt and above)		
35	Pre Medical Check-up & Periodic Medical check-up (every 6 months) including vision test for Operator		
36	Safety Induction for Operator		
37	Others		

Signature & Name of  
Operator:

Signature and name of Job  
Engineer

Signature & Name of Contractor's Safety Officer

FORMAT NO. : HSE-21 REV 0

**Crane Inspection Checklist**

Name of Contractor:

Project:

Name of

Work:

Job No:

Vehicle Identification/Registration No:

Date:

Sr. No.	Description	Observation	Remarks & Suggestions
1	Crane hooks have got smooth surface and no dent		
2	Hook-latch / Dog-clamp in hook is effective		
3	Over hoist limit switch		
4	Over Load Indicator		
5	Over Boom limit switch		
6	Boom angle indicator		
7	Colour coding		
8	Condition of boom		
9	Condition of wire rope		
10	Rope drum / sheaves are in good working condition		
11	Swing break & lock		
12	Swing Alarm		
13	Over hoist break & lock		
14	Boom break & lock (For Telescopic Boom)		
15	Leakage in hydraulic cylinder		
16	Condition of Outrigger (For Tyre Mounted Crane)		
17	Outrigger fully extended Marking (For Tyre Mounted Crane)		
18	Condition of Tyre (For Tyre Mounted Crane)		
19	Wheel chokes are present and are used whenever required (For Tyre mounted)		
20	Battery & lamps		
21	Moving & rotating parts guarded		
22	Load chart provided		
23	Reverse horn (For Tyre Mounted Crane)		
24	Body Condition of crane		
25	Front glass of Operator cabin		
26	Both side Mirror		
27	Number Plate (For Tyre Mounted Crane)		
28	Fire Extinguisher		
29	Horn		
30	Windshield and wipers		
31	Working of light & Indicator		
32	SLI		
33	Spark Arrestor( For Running Refinery/ Petrochemical/Chemical Plant)		

34	Foot-steps and hand-holds are in good working condition for exit /enter in to cabin		
35	TPI,Certificate		
36	RC Document (For Tyre Mounted Crane)		
37	Fitness Certificate of Vehicle by authority		
38	Insurance		
39	PUC		
40	HMV License for Operator		
41	Pre Medical Check-up& Periodic Medical check-up (every 6 months) including vision test for Operator		
42	Safety Induction for Operator		
43	Others		

Signature & Name of  
Operator:

Signature & Name of Contractor's  
Concern Engineer

Signature & Name of Contractor's Safety Officer

FORMAT NO. : HSE-22 REV 0

**Hydraulic Mobile Crane- Inspection Checklist**

Name of Contractor:

Project:

Name of Work:

Job No:

Vehicle Identification/Registration No:

Date:

Sr. No.	Description	Observation	Remarks & Suggestions
1	Identification number of Hydraulic Mobile crane boldly scribed in front and rear end of machine		
2	Operator has got adequate document in support of his competency (i.e. HMV driving license, knowledge & training)		
3	Marking of SWL on hook position is clearly visible		
4	Test & examination of Hydraulic Mobile crane by statutory / competent authority is carried out & document is valid		
5	Colour Coding		
6	RC Document		
7	Fitness Certificate of Vehicle by authority		
8	Valid Insurance		
9	Valid PUC		
10	Pre Medical Check-up & Periodic Medical check-up (every 6 months) including vision test for Operator		
11	Safety Induction for Operator		
12	Crane hooks have got smooth surface and no dent		
13	Hook-latch / Dog-clamp in hook is effective		
14	Over hoist limit switch		
15	Over Load Indicator		
16	SLI		
17	Condition of boom		
18	Condition of wire rope		
19	Rope drum / sheaves are in good working condition		
20	Leakage in hydraulic cylinder		
21	Tyre condition		

22	Battery		
23	Moving & rotating parts guarded		
24	Break		
25	Parking Break		
26	Front horn		
27	Reverse horn		
28	Hydraulic Mobile Crane cabin body and frame of machine is in good order		
29	Both side Mirror		
30	Fire Extinguisher		
31	Front glass pane of the Hydraulic Mobile operator's cabin is clean & clear (i.e. not cracked / damaged / broken)		
32	Windshield and wipers condition		
33	Working of front & back lights, turn Indicators, parking lights & fog lamps		
34	Spark Arrestor( For Running Refinery/ Petrochemical/Chemical Plant)		
35	Wheel chokes are present and are used whenever required		
36	Foot-steps and hand-holds are in good working condition for exit /enter in to cabin		
37	Others		

**Signature & Name of Operator**

**Signature & Name of  
Contractor's Concern  
Engineer**

**Signature & Name of Contractor's Safety Officer**

FORMAT NO. : HSE-23 REV 0

**Hydraulic Rig Inspection Checklist**

Name of Contractor:

Project:

Name of Work:

Job No:

Vehicle Identification/Registration No:

Date:

Sr. No.	Description	Observation	Remarks & Suggestions
1	Control panel is clean & all buttons/switches are clearly visible (no paint over spray, etc.)		
2	All switch & mechanical guards are in good condition and properly installed		
3	All Safety Indicator lights work		
4	Drive controls function properly & accurately labelled (up, down, right, left, forward, back)		
5	Motion alarms are functional		
6	Safety decals are in place and readable		
7	Any defects such as cracked welds, fuel leaks, hydraulic leaks, damaged control cables or wire harness, etc.		
8	Braking devices are operating properly		
9	Winches, pulleys and wire ropes are in good working condition.		
10	Function of interlocks and limit switch		
11	The manufacturer's operations manual (in all languages of the operators)		
12	Oil level, Hydraulic Oil Level, Fuel Level, Coolant Level		
13	Battery Charge		
14	Outriggers in place or functioning. Associated alarms working		
15	Moving & rotating parts guarded		

16	Load chart provided		
17	Fire Extinguisher		
18	Spark Arrestor, if operated by using fuel( For Running Refinery/ Petrochemical/Chemical Plant)		
19	Serial number plate		
20	SLI		
21	TPI Certificate		
22	Colour Coding		
23	Insurance		
24	Pre Medical Check-up& Periodic Medical check-up (every 6 months) including vision test for Operator		
25	Safety Induction for Operator		
26	Others		

**Signature & Name  
of Operator:**

**Signature & Name of Contractor's Concern  
Engineer**

**Signature & Name of Contractor's Safety Officer**

FORMAT NO. : HSE-24 REV 0

**Boom Lift Inspection Checklist**

Name of Contractor:

Project:

Name of Work:

Job No:

Vehicle Identification/Registration No:

Date:

Sr. No.	Description	Observation	Remarks & Suggestions
1	Operating and emergency controls are in proper working condition, EMO button or Emergency Stop Device		
2	Functional upper drive control interlock (i.e. foot pedal, spring lock, or two hand controls)		
3	Emergency Lowering function operates properly		
4	Lower operating controls successfully override the upper controls		
5	Both upper and lower controls are adequately protected from inadvertent operation.		
6	Control panel is clean & all buttons/switches are clearly visible (no paint over spray, etc.)		
7	All switch & mechanical guards are in good condition and properly installed		
8	All Safety Indicator lights work		
9	Drive controls function properly & accurately labelled (up, down, right, left, forward, back)		
10	Motion alarms are functional		
11	Safety decals are in place and readable		
12	Guardrails and anchor points are in place, and in good condition		
13	Work platform & extension slides are clean, dry, & clear of debris		
14	Work platform extension slides in and out freely with safety locking pins in place to lock setting on models with extension platforms.		
15	Any defects such as cracked welds, fuel leaks, hydraulic leaks, damaged control cables or wire harness, etc.		
16	Braking devices are operating properly		
17	The manufacturer's operations manual is stored on AWP (in all languages of the operators)		
18	Oil level, Hydraulic Oil Level, Fuel Level, Coolant Level		

19	Battery Charge		
20	Outriggers in place or functioning. Associated alarms working		
21	Tyres and wheels are in good condition, with adequate air pressure if pneumatic		
22	Wheel chokes are present and are used whenever required		
23	Moving & rotating parts guarded		
24	Load chart provided		
25	Fire Extinguisher		
26	Spark Arrestor, if operated by using fuel( For Running Refinery/ Petrochemical/Chemical Plant)		
27	Serial number plate with Load capacity		
28	TPI Certificate		
29	Colour Coding		
30	Insurance		
31	Pre Medical Check-up& Periodic Medical check-up (every 6 months) including vision test for Operator		
32	Safety Induction for Operator		
33	Others		

**Signature & Name of  
Operator:**

**Signature & Name of  
Contractor's Concern  
Engineer**

**Signature & Name of Contractor's Safety Officer**

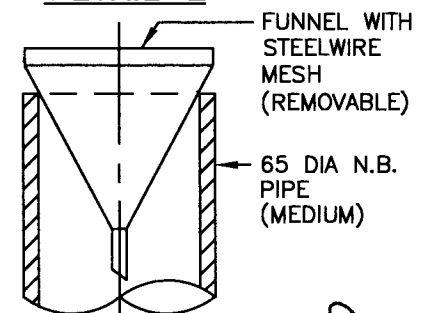
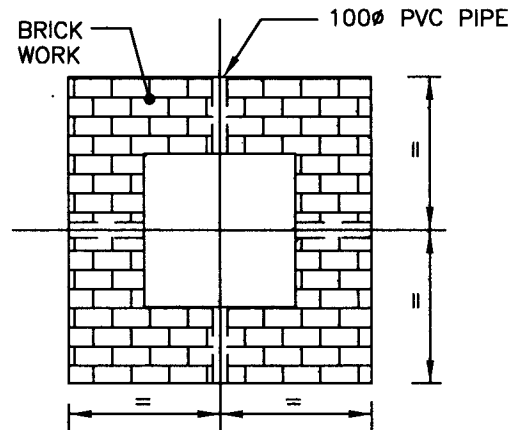
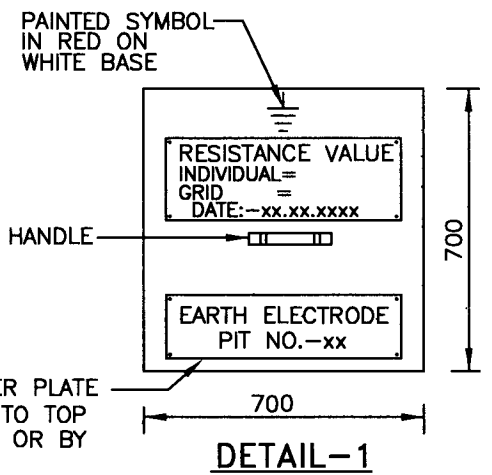
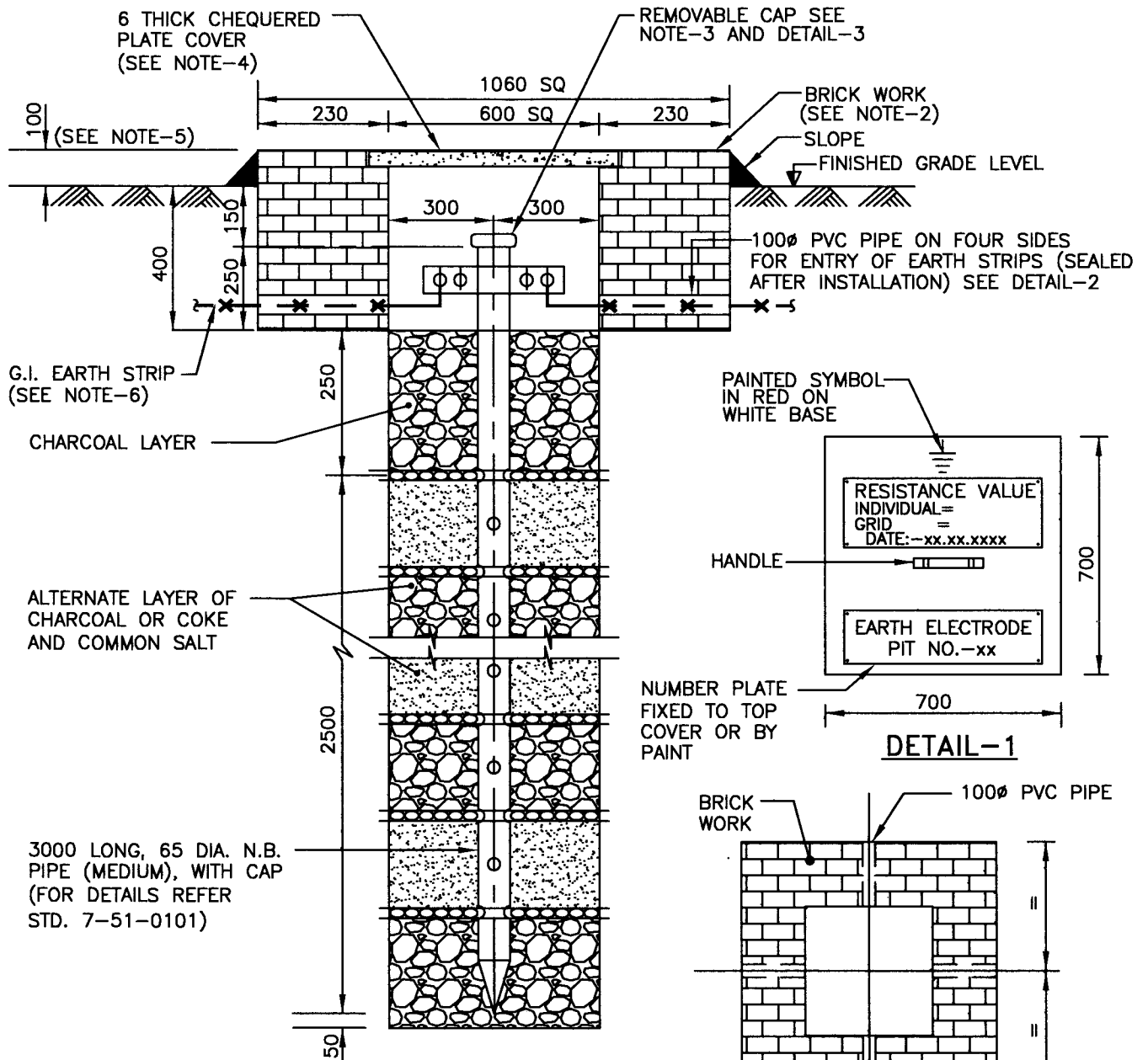

NOTES:-

1. ALL DIMENSIONS ARE IN MM.
2. BRICK WORK SHALL BE DONE AFTER COMPACTING THE SOIL IN UNPAVED AREA.
3. AFTER REMOVAL OF CAP, OWNER SHALL BE ABLE TO POUR WATER THROUGH HIS OWN FUNNEL WITH STEEL WIRE MESH.
4. COLOUR CODING & PAINTING OF COVERS SHALL BE AS PER PAINTING SPEC. NO. 6-79-0020.
5. IN CASE OF PAVED AREAS, TOP OF PIT SHALL BE FLUSHED WITH FFL, WHEREAS IN UNPAVED AREAS, TOP OF PIT SHALL BE PROJECTED 100MM ABOVE FGL.
6. CONNECTIONS OF G.I. EARTH STRIP TO THE PLATE SHALL BE IN LINE WITH STD. 7-51-0103.

8	01.11.21	REAFFIRMED & ISSUE AS STANDARD	JSK	VKS/HK	PG	SM
7	22.11.17	UPDATED & ISSUED AS STANDARD	BP	VKS/HK	BRB	RN
6	08.11.16	UPDATED & ISSUED AS STANDARD	BP	FA/HK	BRB	RN
Rev. No.	Date	Purpose	Prepared by	Checked by	Stds. Committee Convener	Stds. Bureau Chairman

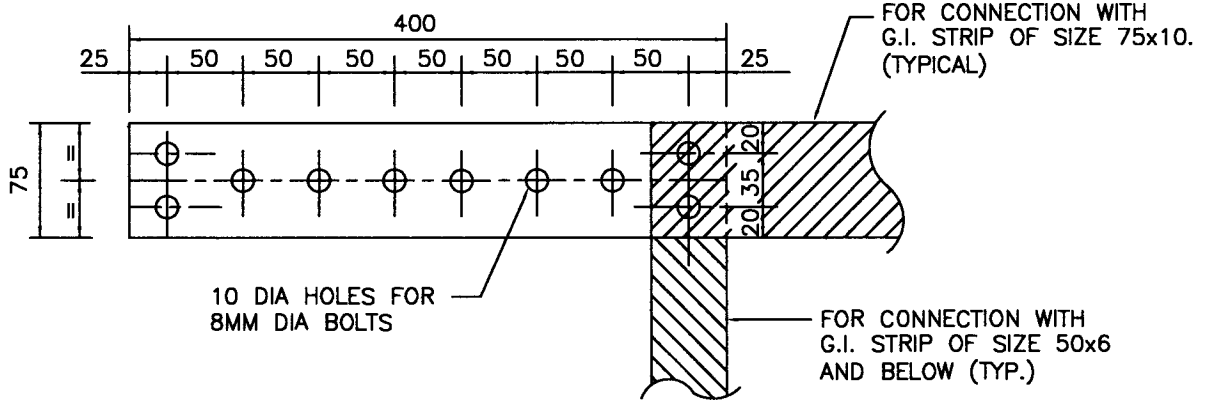

**G.I. EARTH PLATE**

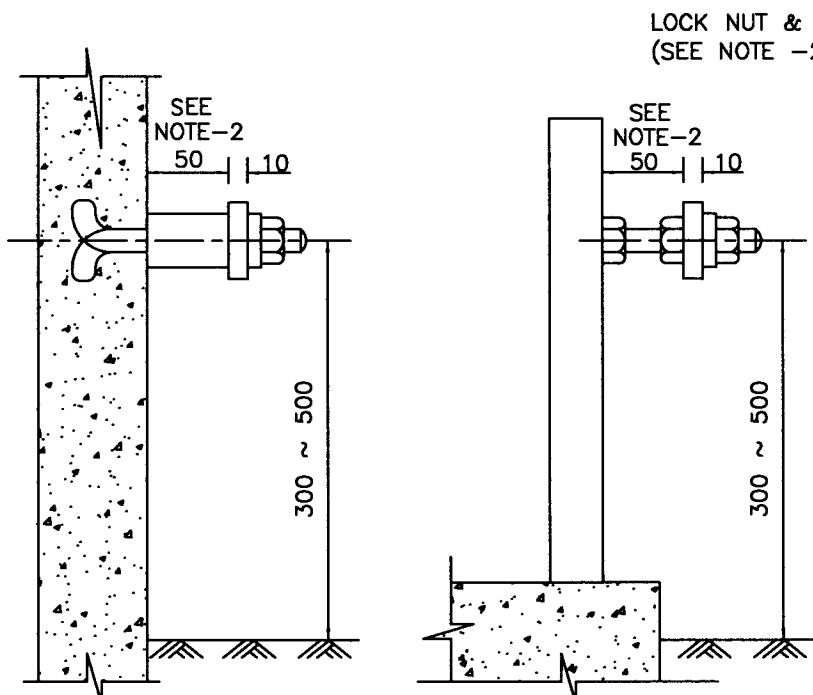
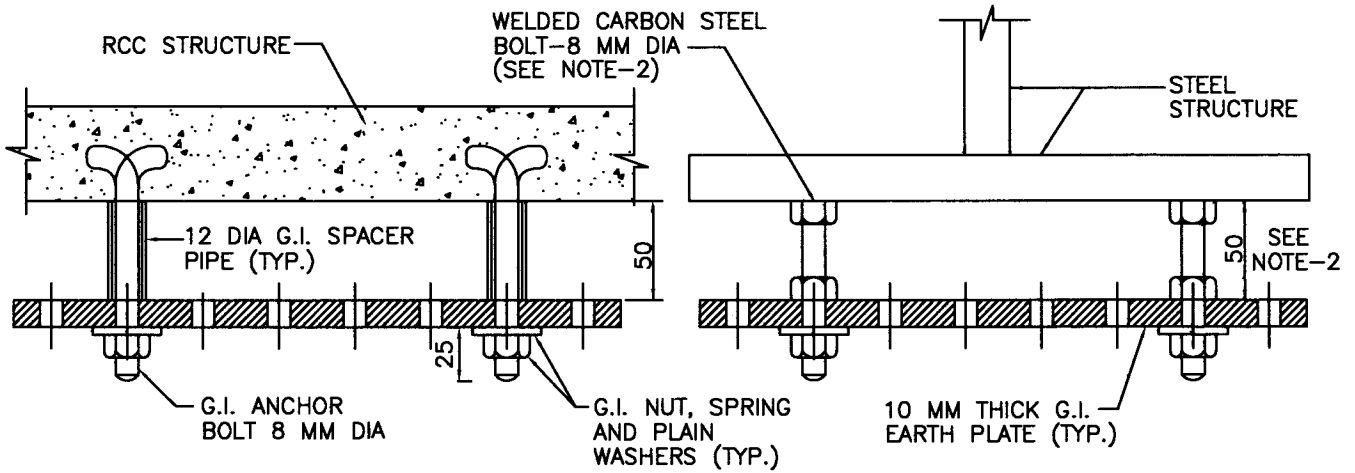

**TYPICAL INSTALLATION OF EARTH PLATE ON R.C.C. STRUCTURES**

**TYPICAL INSTALLATION OF EARTH PLATE ON STEEL STRUCTURES**

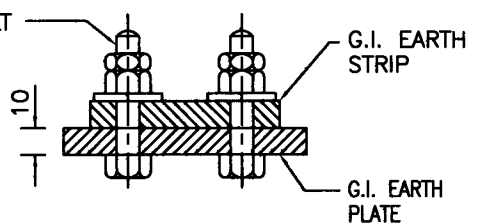

**TYPICAL FIXING DETAIL OF G.I. EARTH STRIP TO EARTH PLATE**

**NOTES:-**

1. ALL DIMENSIONS ARE IN MM.
2. WHERE FIRE PROOFING OF STEEL STRUCTURES ARE ENCOUNTERED LENGTH OF CARBON STEEL BOLTS SHALL BE SUITABLY INCREASED FOR FIXING OF EARTH PLATE.
3. ALL CONNECTIONS WITH EARTH PLATE SHALL BE MADE WITH 8MM DIA. G.I. BOLT, NUT, SPRING AND PLAIN WASHERS.
4. CRIMP TYPE CABLE LUGS SHALL BE USED FOR CONNECTION WITH G.I. WIRE ROPE/GU/AL CABLES.

7	01.11.21	UPDATED & ISSUED AS STANDARD	JSK	VKS/HK	PG	SM
6	08.11.16	UPDATED & ISSUED AS STANDARD	BP	FA/HK	BRB	RN
5	27.06.11	REAFFIRMED & ISSUED	BP	RKS/RSC	UAP	DM
Rev. No.	Date	Purpose	Prepared by	Checked by	Stds. Committee Convener	Stds. Bureau Chairman

ELECTRICAL POWER IS THE MAINSTAY OF ANY CONSTRUCTION ACTIVITY. AT THE SAME TIME IT REQUIRES UTMOST CARE IN IT'S UTILISATION TO AVOID ACCIDENTS DUE TO ELECTRICAL SHOCK, FIRE INCIDENTS OR ELECTRIC SHORT CIRCUITS. EXPOSURE OF ELECTRICAL INSTALLATION TO ADVERSE ENVIRONMENTAL CONDITIONS INCREASE THE RISK OF SUCH ACCIDENTS. HENCE IT IS NECESSARY TO TAKE EXTRA PRECAUTIONS FOR SUCH INSTALLATIONS TO ENSURE SAFETY OF PERSONNEL AND EQUIPMENT. THIS STANDARD ADDRESSES THE SAFETY MEASURES REQUIRED TO BE ADOPTED FOR THE ELECTRICAL INSTALLATIONS BY ALL CONTRACTORS DURING CONSTRUCTION PHASE.

1. ALL ELECTRICAL CONNECTIONS/WORK FOR ELECTRICAL INSTALLATIONS SHALL BE CARRIED OUT AS PER PROVISIONS OF THE LATEST REVISION OF THE FOLLOWING CODES AND STANDARDS IN ADDITION TO THE REQUIREMENTS OF STATUTORY AUTHORITIES AND CEA REGULATIONS-2010.  
OISD-STD-173 : FIRE PREVENTION AND PROTECTION SYSTEM FOR ELECTRICAL INSTALLATIONS.  
OISD-STD-192 : SAFETY PRACTICE DURING CONSTRUCTION.  
SP-30 (BIS) : NATIONAL ELECTRIC CODE.  
THE INSTALLATION SHALL HAVE APPROVAL FROM CONCERNED STATUTORY AUTHORITIES.
2. ALL ELECTRICAL CONNECTIONS SHALL BE DONE BY AN ELECTRICIAN WITH VALID LICENCE AND TO THE SATISFACTION OF ENGINEER-IN-CHARGE.
3. ONE COMPETENT LICENCED ELECTRICIAN SHALL BE MADE AVAILABLE BY CONTRACTOR AT SITE ROUND THE CLOCK TO ATTEND TO THE NORMAL/EMERGENCY JOBS.
4. ALL SWITCH BOARDS/WELDING MACHINES SHALL BE KEPT IN WELL VENTILATED & COVERED SHED. THE SHED SHALL BE ELEVATED TO AVOID WATER LOGGING. NO FLAMMABLE MATERIALS SHALL BE USED FOR CONSTRUCTING THE SHED. ALSO FLAMMABLE MATERIALS SHALL NOT BE STORED IN AND AROUND ELECTRICAL EQUIPMENT/SWITCHBOARD. ADEQUATE CLEARANCES AND OPERATIONAL SPACE SHALL BE PROVIDED AROUND THE EQUIPMENT.
5. FIRE EXTINGUISHERS AND INSULATING MATS SHALL BE PROVIDED IN ALL POWER DISTRIBUTION CENTERS.
6. TEMPORARY ELECTRICAL EQUIPMENT SHALL NOT BE EMPLOYED IN HAZARDOUS AREAS WITHOUT OBTAINING SAFETY PERMIT.
7. PROPER HOUSE KEEPING SHALL BE DONE AROUND THE ELECTRICAL INSTALLATIONS.
8. ALL TEMPORARY INSTALLATIONS SHALL BE TESTED BEFORE ENERGISING, TO ENSURE PROPER EARTHING, BONDING, SUITABILITY OF PROTECTION SYSTEM, ADEQUACY OF FEEDERS/CABLES ETC.
9. ALL WELDERS SHALL USE HAND GLOVES IRRESPECTIVE OF HOLDER VOLTAGE.
10. MULTILINGUAL (ENGLISH, HINDI AND LOCAL LANGUAGE) CAUTION BOARDS, SHOCK TREATMENT CHARTS AND INSTRUCTION PLATE CONTAINING LOCATION OF ISOLATION POINT FOR INCOMING SUPPLY, NAME & TELEPHONE NO. OF CONTACT PERSON IN EMERGENCY SHALL BE PROVIDED IN SUBSTATIONS AND NEAR ALL DISTRIBUTION BOARDS/LOCAL PANELS.
11. OPERATION OF EARTH LEAKAGE DEVICE SHALL BE CHECKED REGULARLY BY PORTABLE ELCB/RCCB TESTER.
12. THE FOLLOWING DESIGN FEATURES SHALL BE ENSURED FOR ALL ELECTRICAL INSTALLATIONS DURING CONSTRUCTION PHASE.
  - 12.1 EACH INSTALLATION SHALL HAVE A MAIN SWITCH WITH A PROTECTIVE DEVICE, INSTALLED IN AN ENCLOSURE ADJACENT TO THE METERING POINT. THE OPERATING HEIGHT OF THE MAIN SWITCH SHALL NOT EXCEED 1.5 M. THE MAIN SWITCH SHALL BE CONNECTED TO THE POINT OF SUPPLY BY MEANS OF ARMoured CABLE.
  - 12.2 THE OUTGOING FEEDERS SHALL BE DOUBLE OR TRIPLE POLE SWITCHES WITH FUSES/MCBs. LOADS IN A THREE PHASE CIRCUIT SHALL BE BALANCED AS FAR AS POSSIBLE AND LOAD ON NEUTRAL SHOULD NOT EXCEED 20% OF LOAD IN THE PHASE.

4	07.12.21	UPDATED & ISSUED AS STANDARD	JSK	VKS/HK	PG	SM
3	08.11.16	REVISED & ISSUED AS STANDARD	BP	FA/HK	BRB	RN
2	02.03.12	REAFFIRMED & ISSUED	BP	RKS/RSC	UAP/JMS	DM
Rev. No.	Date	Purpose	Prepared by	Checked by	Stds. Committee Convenor	Stds. Bureau Chairman
						Approved by

- 12.3 THE INSTALLATION SHALL BE ADEQUATELY PROTECTED AGAINST OVERLOAD, SHORT CIRCUIT AND EARTH LEAKAGE BY THE USE OF SUITABLE PROTECTIVE DEVICES. FUSES WHEREVER USED SHALL BE HRC TYPE. USE OF REWIRABLE FUSES SHALL BE STRICTLY PROHIBITED. THE EARTH LEAKAGE DEVICE SHALL HAVE AN OPERATING CURRENT NOT EXCEEDING 30 mA.
- 12.4 ALL CONNECTIONS TO THE HANDTOOLS/WELDING RECEPTACLES SHALL BE TAKEN THROUGH PROPER SWITCHES, SOCKETS AND PLUGS.
- 12.5 ALL SINGLE PHASE SOCKETS SHALL BE MINIMUM 3 PIN TYPE ONLY. ALL UNUSED SOCKETS SHALL BE PROVIDED WITH SOCKET CAPS.
- 12.6 ONLY 3 CORE (P+N+E) OVERALL SHEATHED FLEXIBLE CABLES WITH MINIMUM CONDUCTOR SIZE OF 1.5 MM<sup>2</sup> COPPER SHALL BE USED FOR ALL HAND TOOLS.
- 12.7 ONLY METALLIC DISTRIBUTION BOXES WITH DOUBLE EARTHING SHALL BE USED AT SITE. NO WOODEN BOXES SHALL BE USED.
- 12.8 ALL POWER CABLES SHALL BE TERMINATED WITH COMPRESSION TYPE NICKEL PLATED BRASS CABLE GLANDS. LUGS OF COPPER/ALUMINIUM/BIMETALLIC MATERIAL, AS APPLICABLE SHALL BE USED FOR MULTISTRAND WIRES/CABLES HAVING MUTISTRAND/SOLID CONDUCTOR.
- 12.9 CABLES SHALL BE FREE FROM ANY INSULATION DAMAGE.
- 12.10 CABLES SHALL BE LAID IN UNDERGROUND AT A MINIMUM DEPTH OF 750 MM, FOR LV & CONTROLS AND 900MM FOR HV CABLES COVERED WITH SAND, BRICK AND SOIL FOR ENSURING MECHANICAL PROTECTION. CABLES SHALL NOT BE LAID IN WATER LOGGED AREA AS FAR AS PRACTICABLE. CABLE ROUTE MARKERS SHALL BE PROVIDED AT EVERY 25 M OF BURIED TRENCH ROUTE. WHEN LAID ABOVE GROUND, CABLES SHALL BE PROPERLY CLEATED OR SUPPORTED ON RIGID POLES OF ATLEAST 2.1 M HIGH. MINIMUM HEAD CLEARANCE OF 6 METERS SHALL BE PROVIDED AT ROAD CROSSING.
- 12.11 UNDER GROUND CABLES SHALL NOT BE ALLOWED TO CROSS THE ROADS WITHOUT PIPE SLEEVE.
- 12.12 ALL CABLE JOINTS SHALL BE DONE WITH PROPER JOINTING KIT. NO TAPED/TEMPORARY JOINTS SHALL BE USED.
- 12.13 AN INDEPENDENT EARTHING FACILITY SHOULD PREFERABLY BE ESTABLISHED WITHIN THE TEMPORARY INSTALLATION PREMISES. ALL APPLIANCES AND EQUIPMENT SHALL BE ADEQUATELY EARTHED. IN CASE ARMOURED CABLES ARE USED, THE ARMOUR SHALL BE BONDED TO THE EARTHING SYSTEM.
- 12.14 ALL CABLES AND WIRE ROPE USED FOR EARTH CONNECTIONS SHALL BE TERMINATED THROUGH LUGS OF TINNED COPPER/ALUMINIUM/ BIMETALLIC MATERIAL, AS APPLICABLE.
- 12.15 IN CASE OF LOCAL EARTHING, EARTH ELECTRODES SHALL BE BURIED NEAR THE SUPPLY POINT AND EARTH CONTINUITY WIRE SHALL BE CONNECTED TO LOCAL EARTH PLATE FOR FURTHER DISTRIBUTION TO VARIOUS APPLIANCES. ALL INSULATED WIRES FOR EARTH CONNECTION SHALL HAVE INSULATION OF GREEN COLOUR.
- 12.16 SEPARATE CORE SHALL BE PROVIDED FOR NEUTRAL. EARTH/STRUCTURES SHALL NOT BE USED AS A NEUTRAL IN ANY CASE.
- 12.17 ON/OFF POSITION OF ALL SWITCHES SHALL BE CLEARLY DESIGNATED/PAINTED FOR EASY ISOLATION IN EMERGENCY.
13. ALL INSULATIONS AND ELECTRICAL INSTALLATIONS SHALL BE INSPECTED BY ENGINEER-IN-CHARGE ATLEAST ONCE IN A MONTH.

4	07.12.21	UPDATED & ISSUED AS STANDARD	JSK	VKS/HK	PG	SM
3	08.11.16	REVISED & ISSUED AS STANDARD	BP	FA/HK	BRB	RN
2	02.03.12	REAFFIRMED & ISSUED	BP	RKS/RSC	UAP/JMS	DM
Rev. No.	Date	Purpose	Prepared by	Checked by	Stds. Committee Convenor	Stds. Bureau Chairman
						Approved by