



ENQUIRY DOCUMENT - MR

(Document No : B862-000-WB-MR-3233-82-RFQ)



Click on the Document Title to go to that section of the document

Table of Contents			
Document Number	Rev.	Document Title	Page Number
B862-000-WB-MR-3233-82-RFQ	A	ENQUIRY DOCUMENT - MR	3
B862-000-WB-MR-3233	A	VALVES-GATE, GLOBE & CHECK (LT & CRYO)-FORGED	187
B862-000-16-43-ATR-3233	A	ADDITIONAL TECHNICAL REQUIREMENTS FOR VALVES-GATE, GLOBE & CHECK (LTCS & CRYO)-FORGED	191
B862-000-6-44-0006-3233	A	VMS sheets for MR 3233	194
6-44-0052	9	Technical notes for valves	208
6-81-0004	7	Inspection and test plan for valves	231
6-81-0001	4	Standard specification for positive material identification (PMI) at supplier's works	239
6-78-0001	3	Specification for quality management system requirements from bidders / suppliers / contractors	247
6-78-0003	3	Specification for documentation requirements from suppliers	254



BIDDING DOCUMENT NO. JP/B862-000-WB-MR-3233/82

**BIDDING DOCUMENT
FOR
VALVES-GATE, GLOBE & CHECK (LT & CRYO)-FORGED
FOR
PDH PP PLANT WITH ETHANE AND PROPANE HANDLING
FACILITIES PROJECT AT DAHEJ, GUJARAT**

Prepared & Issued by:



MASTER INDEX

NAME OF WORK : VALVES-GATE, GLOBE & CHECK (LT & CRYO)-FORGED

BIDDING DOCUMENT NO. : JP/B862-000-WB-MR-3233/82

COMMERCIAL SECTION	
S. NO.	DESCRIPTION
1.	COVER PAGE
2.	MASTER INDEX
3.	REQUEST FOR QUOTATION
4.	BID DATA SHEET
5.	BIDDING FORMS
6.	AGREED TERMS & CONDITIONS (INDIGENOUS)
7.	INSTRUCTION TO BIDDERS (ITB)
	ANNEXURES TO ITB
	i. ANNEXURE-I TO ITB – E-TENDERING METHODOLOGY
	ii. ANNEXURE-II TO ITB – RESTRICTIONS ON PROCUREMENT FROM BIDDERS FROM COUNTRY(IES) SHARING LAND BORDER WITH INDIA
8.	SPECIAL CONDITIONS OF CONTRACT FOR GOODS
	ANNEXURES TO SPC
	i. ANNEXURE-I: TERMS & CONDITIONS FOR INDIAN SOURCED COMPONENTS BY FOREIGN BIDDER
	ii. ANNEXURE-II: TAXES & DUTIES
	iii. ANNEXURE-III: TERMS & CONDITIONS FOR SUPERVISION OF ERECTION, TESTING & COMMISSIONING/TRAINING AT SITE/HAZOP STUDY - Not Applicable
	iv. ANNEXURE-IV: TERMS & CONDITIONS FOR INSTALLATION / SITE WORK -Not Applicable
	v. ANNEXURE-V: TERMS & CONDITIONS FOR ANNUAL MANTAINENANCE CONTRACT (AMC) - Not Applicable
	vi. ANNEXURE-VI: TERMS & CONDITIONS FOR TRAINING AT OEM WORKS
	vii. ANNEXURE-VII: PROFORMA FOR ADVANCE REPAYMENT BANK GUARANTEE
	viii. ANNEXURE-VIII: FORMAT FOR CONTRACT PERFORMANCE BANK GUARANTEE
9.	GENERAL PURCHASE CONDITIONS
10.	PACKING, MARKING, SHIPPING AND DOCUMENTATION SPECIFICATIONS (INDIGENOUS)
11.	PRICE SCHEDULE
TECHNICAL SECTION	
MR No. B862-000-WB-MR-3233	

REQUEST FOR QUOTATION (RFQ)
(e-Bidding)
Limited –Indigenous
(Composite Bidding)

Date: 27.04.2026

SL NO.	SALIENT FEATURES	DETAILS
a)	Client	: Petronet LNG Limited (Petronet LNG Petrochemical Project)
b)	Project	: PDH PP PLANT WITH ETHANE AND PROPANE HANDLING FACILITIES PROJECT AT DAHEJ, GUJARAT
c)	Item	: VALVES-GATE, GLOBE & CHECK (LT & CRYO)-FORGED
d)	EIL RFQ No.	: JP/B862-000-WB-MR-3233/82
e)	MR Category	: I
f)	Pre-Bid Meeting	: Not Applicable
g)	Pre-Bid Meeting Details and Venue	: Not Applicable
h)	Last date of receipt for pre-bid queries	: Before 1855 Hrs. on 04.05.2026 Bidder shall submit their queries only through NIC-CPP portal strictly on or before cut-off date mentioned in RFQ after which, EIL shall reserve the right not to entertain any queries. Queries sent through e-mails or any other mode by any bidder may not be given any cognizance.
i)	Earnest Money Deposit (EMD)	: Not Applicable
j)	Bid Due Date (Last date and time of submission of e-Bids)	: 18.05.2026; 1200 HRS
k)	Composite Bid Opening Opening date of Techno-commercial e-Bids	: 19.05.2026; 1400 HRS (*) If date(s) identified as (*) above happen to be a declared holiday in EIL Gurugram, the next working day shall be considered.
l)	Contact Person for any query/ clarification	: Mr. Mohit Gautam, Dy. Manager (SCM-C&P), Phone No. 0124 289 1349 E-mail ID: mohit.kumar@eil.co.in Mr. Ranjit Vunna, AGM (SCM-C&P), Phone no. 0124 289 1338 E-mail ID: ranjit.vunna@eil.co.in Mr. Jaydip Purkayastha, GM (SCM-C&P), Phone no. 0124 289 1287, E-mail ID: jaydip@eil.co.in
m)	e-Tendering portal for submission of Non Disclosure Agreement (NDA) & e-bids	: NOT APPLICABLE
n)	Delivery Period/ Completion Period	: Within 08 (Eight) Months on FOT Site basis from the date of PO (Purchase order).

SL NO.	SALIENT FEATURES	DETAILS
		<p>The date of receipt of material at site shall be considered as date of delivery.</p> <p>Suppliers are required to dispatch the goods on prepaid door delivery basis through any registered Transporters on FOT Site basis.</p>
o)	INTEGRITY PACT	NOT APPLICABLE
p)	REVERSE AUCTION	NOT APPLICABLE
q)	PERIOD OF VALIDITY OF BIDS	Bid shall remain valid for a period of THREE MONTHS from final/extended due date of submission of Bid.
r)	DEVIATIONS NOT PERMITTED	<p>Bids are invited on "Zero Deviation Basis". Accordingly offer is to be submitted in complete compliance to RFQ Terms & Conditions without any deviation. Offer with deviation shall be liable for rejection.</p> <p>Hence, Bidder shall ensure submission of complete bid without any deviation as per requirement of Enquiry document in first instance itself.</p>
s)		<p>This enquiry is issued on Limited Bidding basis for "captioned items mentioned at sl. No. c above" only. A separate intimation to the suppliers eligible for this enquiry shall be sent through e-mail subsequent to issuance of enquiry on e-procurement Portal.</p> <p>Only those suppliers who are intimated of publication of the enquiry through EIL e-mail will be eligible to submit their bids. Bids received from any other supplier shall not be considered for evaluation and shall be rejected.</p> <p>In case a bidder does not register on the e-procurement Portal and as a consequence, does not submit their bid on the Portal, it shall be deemed that he is not interested in bidding against this enquiry and no further correspondence will be entertained.</p>
t)	RESTRICTIONS ON PROCUREMENT FROM BIDDERS FROM COUNTRIES SHARING BORDER WITH INDIA	<p>Department of Expenditure (Govt. of India) vide OM no. 7/10/2021-PPD (1) DATED 23.02.2023 has issued the revised Guidelines for Restriction on Procurement from Bidders from Countries sharing Border with India.</p> <p>Bidder is advised to refer to the guidelines (annexed with Instruction to Bidders (ITB) of this bidding document) and ensure compliance to the same.</p>

Dear Sir/Madam,

- Petronet LNG Limited (PLL) is a public limited company incorporated in April 1998 in India under the provision of the (Indian) Companies Act 1956, having registered office at 1st floor, World Trade Centre, Babar Road, Barakhamba Lane, New Delhi, PIN – 110001. PLL owns & operates LNG Terminal at Dahej in the state of Gujarat, India with the name plate capacity of 17.5 MMTPA. In view of expected growth in demand for petrochemical products in India and to remain competitive in the market with product self-sufficiency, Petronet LNG Ltd. (PLL) has planned to setup Petrochemical (PDH-PP) plant integrated with Ethane and Propane import facility at Dahej. The proposed Petrochemical Complex will use propane as a feedstock, dehydrogenate it to form propylene in a Propane Dehydrogenation Unit (PDH) and further polymerize to produce Polypropylene in a PP unit targeting import substitution.

Engineers India Limited (EIL) has been engaged by PLL for Consultancy services for 750 KTA PDH Plant and 500 KTA PP plant with Ethane and Propane Storage and Handling Facility at Dahej Petrochemical complex.
- E-bids under **single stage single bid (composite) system** are requested for the captioned item based on the requirement specified in this MR and in total compliance to technical specifications, scope and terms & conditions of RFQ documents/attachments.
- Bidders are required to register themselves at <http://eprocure.gov.in/eprocure/app>. No registration fee would be charged from the bidders.

4. Bidder can download the RFQ Documents from e-tendering website of CPP portal (<http://eprocure.gov.in/eprocure/app>). All amendments, time extension, clarifications etc. will be uploaded in CPP Portal only. Bidders should regularly visit the above website to keep themselves updated. No extension in the bid due date / time shall be considered on account of delay in receipt of any document by mail.

Provisions mentioned in Instruction to Bidders with regard to uploading of bidding document, replies/clarifications to bidder queries, techno-commercially amendments etc., on EIL website shall stand modified to the extent that these shall be uploaded on CPP portal only.

5. Bidders to refer E-Tendering methodology enclosed with this RFQ. Various links such as “Help for Contractor”, “Information about DSC”, “FAQ”, “Resources Required”, “Bidders Manual Kit” etc. are available on home page of <http://eprocure.gov.in/eprocure/app> facilitating vendors to participate in the bidding process. Bidder are advised to download & utilize the available information/documents under these links for activities like Registration in CPPP, obtaining User ID & Password, uploading & submission of e-bids etc. Bidders are advised in their own interest to carefully go through Instructions for E-tendering and other related document available against various help links so as to ensure that bids are uploaded in E-tendering website well before the closing date and time of bid submission.
6. NIC Portal mandates that the bidders are to be registered on the portal before any enquiry can be issued to them. In order to expedite issue of enquiries, the information of enquiry is being issued through EIL Tender Portal, however, document shall be available on Central Public Procurement Portal. The name of bidder whose NIC ID details are submitted/available to EIL shall be issued the enquiry and enquiry to the balance bidders can only be issued once they will register themselves on NIC portal and provide their registration details to EIL.

Therefore, all those vendors who have still not registered on the NIC Portal are required to register on the same (immediately after issue of enquiry) and inform the undersigned the registration details for facilitating issue of enquiry to them on the NIC Portal failing which it will not be possible for them to upload their bids.

All those bidders who have not complied with the above registration requirements will not be issued this enquiry on NIC portal and will not be eligible to bid. Request for extension in due date of submission of bids due to non-registration or delayed registration in NIC portal shall not be entertained.

7. All amendments, time extension, clarifications etc. will be uploaded in CPP portal (<http://eprocure.gov.in/eprocure/app>) only. Bidders should regularly visit the e-tendering website to keep themselves updated. No extension in the bid due date / time shall be considered on account of delay in receipt of any document by Mail/Post.
8. Bidders are required to submit their bids complete in all respects in accordance with Instructions to Bidders (ITB) only through e-tendering website of CPP portal (<http://eprocure.gov.in/eprocure/app>) **on or before the bid-submission due date & time** as specified above. Bidder to carefully read and understand the instructions for e-tendering as indicated in ITB to upload their bid on e-tendering website.

Physical Bids sent through Fax/E-mail/Courier/Post will not be accepted. However, any specific document required to be submitted in physical form as per RFQ shall also be submitted in physical form.

9. The vendor registration on NIC Portal is a very user-friendly process. However, in case of any doubt, the vendor may contact the undersigned.

Bidder(s) are advised to upload their bid as soon as they are permitted to upload the bid. In the event of failure in bidder's connectivity with e-tendering Portal during the last few hours on account of any problem and they are likely to miss the deadline for bid submission in such a case request for extension in bid due date will not be entertained.

10. Please submit your Acknowledgement against the RFQ on EIL's website <http://tenders.eil.co.in> within the due date & time, with reason(s) of not participating in the bidding process in case of regret/negative acknowledgment. In case there is no response, the bidder shall be liable for suitable action including review of their enlistment with EIL for the subject item.
11. Submission of authentic documents is the prime responsibility of the bidder. Wherever EIL has concern or apprehension regarding the authenticity/ correctness of any document, EIL reserves a right of getting the document cross verified from the document issuing authority.

12. **Bidders are mandatorily required to indicate their name on each page of excel file / pdf file of Un-priced copy of Price Schedule while uploading the same.**
13. Bidder to note that the Inspection shall be carried out in line with Inspection Philosophy mentioned in RFQ Documents.
14. RFQ Document is non-transferrable.
15. Subsequent to the opening of bid, bidders are not allowed to change the price or substance of the bid i.e. scope of work, specifications, delivery schedule, completion period etc.
16. Consortium / Unincorporated Joint Venture Bids are not acceptable.
17. PLL/EIL reserves the right to assess Bidder's capabilities and capacity to execute the work using in-house information. Further in case Purchase Order awarded for the tendered work have to be terminated due to supplier's default and separate enquiry have to be floated to get the remaining / complete work executed, such defaulting supplier will not be considered for enquiries issued for the refloated works of the same project.
18. In case any bidder is found to be involved in cartel formation, his bid will not be considered for evaluation/placement of order. Such bidder will be debarred from bidding in future.
19. Canvassing in any form by the Bidder or by any other Bidder on their behalf may lead to disqualification of their Bid.
20. The bidder shall bear all costs associated with the preparation (including site visit, if required and other expenses incurred during bidding process) and submission of its bid, and the Purchaser/EIL shall in no case be responsible or liable for such costs regardless of the conduct or outcome of the bidding process.
21. EIL reserves the right to reject any or all Bids received and to annul the Bidding Process at its discretion without assigning any reason, whatsoever.
22. For detailed specifications, terms and conditions and other details, refer complete Bidding Document.

***Please specify EIL RFQ No. in all correspondence**

This limited invitation for e-bid is open only to suppliers to whom this RFQ is issued.

THIS IS NOT AN ORDER.

Very truly yours,

(Jaydip Purkayastha)
GM (SCM-C&P)
Engineers India Limited

BID DATA SHEET **(BDS)**

BID DATA SHEET		
S.NO.	CL. NO.	CONTENT
1.	ITB 3.0 ELIGIBLE BIDDERS	Enquiry Basis is: Limited Domestic Competitive Bidding
2.	ITB 3.0 ELIGIBLE BIDDERS NEW SUB-CLAUSE 3.7 (g)	The following clause is NOT APPLICABLE for this enquiry. In cases of entity, quoting on behalf of their principal manufacturers, one stockiest/distributor/authorized seller cannot represent two manufacturers or quote on their behalf in a particular tender enquiry. One manufacturer can also authorize only one stockiest/distributor/authorized seller. There can be only one bid from the following: <ul style="list-style-type: none"> I. The principal manufacturer directly or through one entity on his behalf; and II. Entity on behalf of only one principal.
3.	ITB 3.0 ELIGIBLE BIDDERS NEW SUB-CLAUSE 3.9	The following clause is NOT APPLICABLE for this enquiry. <u>3.9 BIDS FROM INDIAN/ FOREIGN COUNTERPART ON BEHALF OF FOREIGN BIDDER</u> Wherever a limited enquiry is issued to a foreign company, being approved OEM (the manufacturer) and enlisted with Owner/EIL, but the OEM requests to bid through a bidder which maybe his subsidiary or his parent or another subsidiary of his parent, following methodology shall be followed: <ul style="list-style-type: none"> a. A company shall be considered as subsidiary of its parent company if the parent company: <ul style="list-style-type: none"> ➤ Controls the composition of the board of directors of the subsidiary; or ➤ Controls more than half of the voting right of the subsidiary; or ➤ Owns more than half of the paid-up equity of the subsidiary; For the purpose of definition of subsidiary, if a company A is a subsidiary of company B which is, in turn, a subsidiary of company C then company A will be considered to be a subsidiary of company B as well as C. b. Bidder may be Indian or foreign. c. Bidder may or may not be a manufacturer of the offered products. d. Bidder may or may not be enlisted with EIL. e. In case bidder proposes to ship the material from a warehouse/ works which may or may not be enlisted with Owner/EIL, the same shall be considered acceptable subject to following conditions: <ul style="list-style-type: none"> i. All items to be sourced (duly inspected under TPI) from OEM except minor outsourced accessories and the methodology for their assembly by Bidder will be spelt out in the offer by bidder. ii. EIL/ Third Party Inspection (as applicable) shall

BID DATA SHEET		
S.NO.	CL. NO.	CONTENT
		<p>be conducted before despatch of the items from OEM works.</p> <p>iii. OEM shall issue an authorization by the authorized signatory to the Bidder towards the above arrangement.</p> <p>iv. OEM shall furnish a backup corporate guarantee duly signed by the authorized signatory towards the performance of the equipment & accessories.</p> <p>v. In case engineering work is undertaken by bidder, responsibility matrix will be submitted, duly signed by OEM.</p> <p>vi. PO shall be on the Bidder and shall specify the OEM works as well as the final despatch point.</p>
4.	ITB 3.0 ELIGIBLE BIDDERS NEW SUB-CLAUSE 3.10	<p>The following clause is NOT APPLICABLE for this enquiry.</p> <p><u>3.10 BIDS FROM INDIAN/FOREIGN COUNTERPART ON BEHALF OF FOREIGN BIDDER</u></p> <p>i. In case the enquiry is issued to a Foreign bidder on limited basis and offer is received from their Indian/Foreign counterpart on behalf of Foreign bidder, the same is acceptable provided counterpart furnishes authorization and confirmation from Foreign bidder that the commitment made by their counterpart during the bidding stage shall be acceptable to them.</p> <p>ii. In such a case, order shall be issued on Foreign bidder and material shall be supplied from their approved works only</p>
5.	ITB 12.1.1, ITB 19.0& ITB 21.0 POSTAL ADDRESS & CONTACT DETAILS FOR SUBMISSION OF DOCUMENT (VIZ. BID SECURITY, ETC.)IN PHYSICAL FORM, IF ANY, AS PER RFQ	<p>Jaydip Purkayastha, GM (SCM-C&P) Engineers India Limited, EIL Office Complex, Sector 16, Gurugram-122004 Telephone: 0124 – 289 1349/ 1308 / 1287 e-mail id: mohit.kumar@eil.co.in/ ranjit.vunna@eil.co.in / jaydip@eil.co.in</p>
6.	ITB 12.1.2 LIST OF DOCUMENTS	<p>a. Agreed Terms & Conditions for Indigenous bidders, duly filled, signed & stamped on all pages and complete in all respects.</p> <p>b. Bank Certified Mandate Form as per Form-A duly signed and stamped with the Banker's certification or cancelled cheque.</p> <p>c. Price copy of Price Schedule</p> <p>d. Signed and stamped copy of Form-IA and Form-II, as applicable, (on Company's Letterhead) attached with Annexure-II of ITB in line with Government guidelines regarding procurement from bidders from a country or countries sharing Land Border with India.</p> <p>e. Scanned copy of Addendum / Amendment (if any).</p> <p>f. Power of Attorney (PoA) and/or Board Resolution in</p>

BID DATA SHEET		
S.NO.	CL. NO.	CONTENT
		<p>favour of Bid Signatory as stipulated in ITB 20.0 in the e-bid.</p> <p>g. Power of Attorney (PoA) and/or Board Resolution in favour of Digital Signatory Holder as stipulated in ITB 20.0 in the e-bid. (if other than bid signatory)</p> <p>h. Valid GST Registration Certificate.</p> <p>i. Any other documents required as per Material Requisition (MR).</p> <p>j. Any other document as stipulated in the bidding document.</p>
7.	ITB 34.0 & ITB 36.0 EVALUATION OF TECHNO-COMMERCIAL BIDS & EVALUATION AND COMPARISON OF BIDS	<p>Evaluation shall be on Item wise basis.</p> <p>100% Input Tax Credit is available with PLL.</p>
8.	ITB 42.0 & SCC 2.2 (vi), SCC 6 CONTRACT CUM PERFORMANCE BANK GUARANTEE (CPBG)	<p>APPLICABLE</p> <p>Note:</p> <p>i. Bidder may submit an Insurance Surety Bond in lieu of Performance Bank Guarantee. The Insurance Company issuing the Bond shall have a credit rating of AA from CRISIL / ICRA. This rating requirement shall not be applicable to Public Sector Insurance Companies.</p>
9.	ITB 42.0 & SCC 2.2 (vi), SCC 6 CONTRACT CUM PERFORMANCE BANK GUARANTEE (CPBG)	<p>Bank Guarantees towards CPBG/ABG shall be accepted only when issued from a "Acceptable Bank". The Definition of "Acceptable Bank" shall be as follows:</p> <p><i>"Acceptable Bank" shall mean the State Bank of India constituted under the State Bank of India Act 1955; or a "Schedule Commercial Bank (in the category of Public Sector Banks and Private Sector Banks)" in India (as defined under the Reserve Bank of India Act, 1934) whose long term debt is rated at least AA- (AA Minus) by CRISIL Ltd. or assigned an equivalent rating by some other Indian Credit Rating Agency, ICRA, CARE or India Ratings, and acceptable to PLL in its sole discretion, or an international bank (having a branch in India)(Scheduled Foreign Banks in India) whose long term debt is rated at least A- (A minus) (or equivalent) by Standard & Poor Corporation / Fitch Ratings or A3 (or equivalent) by Moody's Investor Services."</i></p> <p>In case, where more than one Rating is taken by Bank, lowest rating shall be considered for Acceptance of Bank.</p> <p>Any Foreign Bank which is not a Scheduled Foreign Bank in India is also acceptable provided that offered documents like BG/LC etc. are counter guaranteed by any Indian Bank meeting the criteria of Acceptable Bank.</p>
10.	ITB NEW CLAUSE 50.0 SHIFTING OF ORDER	The following clause is NOT APPLICABLE for this enquiry.

BID DATA SHEET		
S.NO.	CL. NO.	CONTENT
		<p>50.0 SHIFTING OF ORDER</p> <p>The following philosophy shall be followed for shifting: Based on lowest evaluated item wise prices, the shifting shall be carried out provided the following conditions are met:</p> <ol style="list-style-type: none"> Shifting shall be done only if shifting cost of each order is upto Rs. 2,00,000/-. Shifting shall not be resorted to if the value of the order is more than 25% of the total order value of the recommendation. However, this ceiling will not be applicable where total order value of recommendation is upto Rs. 8.0 Lakh. In case the order value on L1 bidder is more than Rs 5,00,000/- then shifting shall not be resorted to. <p>With above shifting the selected bidder for award will be deemed to be L1 bidder.</p>
11.	SCC 2.0 PAYMENT TERMS	<ol style="list-style-type: none"> 15% against identification of raw materials at Supplier's works and against submission of ABG of equivalent amount. 65% against dispatch documents (along with copy of LR/GR and IRN) directly to EIL together with full taxes, duties and transportation charges. 10% against receipt and acceptance of material at site 10% against receipt and acceptance of all material at site.
12.	SCC 2.0 EIL vis-a-vis Supplier Commitments	NOT APPLICABLE
13.	SCC 3.0 TRANSPORTATION	ODC / CRITICAL CONSIGNMENT: NOT APPLICABLE
14.	SCC 8.2 PRICE VARIATION	NOT APPLICABLE
15.	SCC 11.0 MARINE CUM INSURANCE DETAILS	Marine Cum Erection Insurance Policy Is Enclosed As Annexure to SCC
16.	SCC 12.1.5 & 12.2.6 LOADING AND PENALTY CRITERIA (LPC) OF MR	<p>The following clause is NOT APPLICABLE for this enquiry.</p> <p>LOADING AND PENALTY CRITERIA (LPC) OF MR</p> <p>In partial modification to the provisions of LPC Criteria of MR, it is being clarified that Freight and Duties along with its applicable taxes (applicable for Foreign Bidder) shall also be considered for calculation of Total Cost and Capital Cost for calculation of Loading Amount.</p>
17.	SCC 16.0 PART ORDER	APPLICABLE (ITEMWISE)

BID DATA SHEET		
S.NO.	CL. NO.	CONTENT
18.	GCC 24.0, SCC17.0 REPEAT ORDER	APPLICABLE
19.	SCC 19.0 TERMS & CONDITIONS FOR SUPERVISION OF ERECTION, TESTING & COMMISSIONING /TRAINING AT SITE / HAZOP / SUPERVISION OF PGTR	NOT APPLICABLE
20.	SCC 20.0 TERMS & CONDITIONS FOR INSTALLATION/SITE WORK	NOT APPLICABLE
21.	SCC 21.0 TERMS & CONDITIONS FOR ANNUAL MAINTENANCE CONTRACT (AMC)	NOT APPLICABLE
22.	SCC 22.0 TERMS & CONDITIONS FOR TRAINING AT SUPPLIER/OEM WORKS	NOT APPLICABLE
23.	ANNEXURE II TO SCC CLAUSE NO. B-2 IMPORT DUTIES	Merit Rate of Customs Duty shall be applicable for this enquiry.
24.	IFB 11.0 NEW CLAUSE TO IFB	<p>The following clause is NOT APPLICABLE for this enquiry.</p> <p><u>WHEREVER BIDDER IS INTENDING TO QUALIFY AS AT LEAST 51% OWNED INDIAN SUBSIDIARY OF A FOREIGN PRINCIPAL (AS PER MR/TECHNICAL BQC)</u></p> <p>In addition to the provision to the bidding document, Bidder shall comply the following:</p> <ul style="list-style-type: none"> Extended warranty: The bidder shall provide extended warranty of 12 months over & above the guarantee/warranty period specified in the Bidding Document. <p>Additional PBG:</p> <p>The Principal or the Group Company (as the case may be) shall furnish the Performance Bank Guarantee, equivalent to 5% of Total Contract Value. The performance Bank Guarantee by Principal or Group Company shall be additional to PBG (i.e. equivalent to 10% of the Total Contract Value) required to be submitted by the successful bidder.</p> <p>In case where Principal or the Group Company does not have Permanent Establishment in India as per Indian Income Tax Act, the bidding company (Bidder) can furnish Performance Bank Guarantee for an amount which is sum of PBG amount to be submitted by the bidder and additional PBG amount required to be submitted by the</p>

BID DATA SHEET		
S.NO.	CL. NO.	CONTENT
		<p>Principal or the Group company (i.e. equivalent of 15% of the Total Contract Value).</p> <p>Also, in such as case bidding company shall furnish an undertaking that their foreign based Principal or the Group Company, is not having any permanent establishment in India in terms of Income Tax Act of India.</p> <p>Undertaking from the Principal or the Group Company to the effect that in addition to invoking the PBG submitted by the bidding company, the PBG provided by the Principal or the Group Company can be invoked by PLL due to non-performance of the bidding company.</p>

BIDDING FORMS

BANK MANDATE FORM
(As per ITB)

- 1. Bidder Name :
- 2. Bidder Code :
- 3. Address of the Bidder :
- 4. Particulars of Bank Account of Bidder :
 - a. Name of the Bank :
 - b. Name of the Branch and Address of the Branch :
 - c. Branch Code : :
 - d. 9-Digit MICR code Number of the Bank & Branch :
(As appearing in the MICR Cheque issued by the bank) :
(Please do not give multicity cheque book code :
Number)
 - e. Type of account (Saving Bank, Current or Cash Credit) :
 - f. Account Number :
 - g. RGTS/IFSC Code (11 digit) :
 - h. NEFT Code No. :
- 5. E-mail address of the Bidder :
- 6. Contact Person(s) of the Bidder :

I/we declare that the particulars given above are correct and complete and I/we accord our consent for receiving all our payments through Electronic Mechanism.

(Signature and designation of the Authorised person(s) of Bidder)

Official seal of the Bidder

Place :

Date :

BANK CERTIFICATION

Certified that the particulars furnished above are correct as per our records.

Place :

Date :

Signature of the Authorised Official of the Bank

Bank's Stamp

FORMAT FOR BIDDERS' QUERIES (PRE-BID)
(AS PER ITB)

RFQ Document No. : _____

SL. NO.	REFERENCE OF ENQUIRY DOCUMENT				BIDDER'S QUERY	EIL REPLY
	PART/VOL.	PAGE NO.	CLAUSE NO.	SUBJECT		

NOTE:

1. The Pre-Bid Queries in the above format shall be uploaded by the bidder on CPP Portal within the cut off date as per the bidding document.

SIGNATURE OF BIDDER : _____

NAME OF BIDDER : _____

FORM-C

TAX RESIDENCY CERTIFICATE

TRC obtained by the Non-resident from Government of foreign country shall contain the following particulars:

- 1) Name of the assessee :
- 2) Status (individual, company, firm, etc.) of the assessee:
- 3) Nationality (in case of individual) :
- 4) Country or specified territory of incorporation or registration (in case of others):
- 5) Assessee's tax identification number in the country or specified territory of residence or in case of no such number, then a unique number on the basis of which the person is identified by the Government of the country or the specified territory:
- 6) Residential status for the purpose of Tax:
- 7) Period for which the certificate is applicable:
- 8) Address of the applicant for the period for which the certificate is applicable:
- 9) Name of the assessee:

FORM NO.10 F

[See sub-rule (1) of rule 21AB]

Information to be provided under sub-section (5) of section 90 or sub-section (5) of section 90A of the Income-tax Act, 1961

I _____ *son/daughter of Mr. _____ in the capacity of _____ (designation) do provide the following information, relevant to the previous year _____ *in my case/in the case of _____ for the purposes of sub-section (5) of *section 90/section 90A:-

Sl. No.	Nature of information	Details#
(i)	Status (individual, company, firm etc.) of the assessee	:
(ii)	Permanent Account Number (PAN) of the assessee if allotted	:
(iii)	Nationality (in the case of an individual) or Country or specified territory of incorporation or registration (in the case of others)	:
(iv)	Assessee's tax identification number in the country or specified territory of residence and if there is no such number, then, a unique number on the basis of which the person is identified by the Government of the country or the specified territory of which the assessee claims to be a resident	:
(v)	Period for which the residential status as mentioned in the certificate referred to in sub-section (4) of section 90 or sub-section (4) of section 90A is applicable	:
(vi)	Address of the assessee in the country or territory outside India during the period for which the certificate, mentioned in (v) above, is applicable	:

I have obtained a certificate referred to in sub-section (4) of section 90 or sub-section (4) of section 90A from the Government of _____ (name of country or specified territory outside India).

Signature:

Name:

Address:

Permanent Account Number:

Verification

I _____ do here by declare that to the best of my knowledge and belief what is stated above is correct, complete and is truly stated.

Verified today the _____ day of _____

Signature of the person providing the information

Place:

Project / Client:
RFQ No.:
Item:
Notes: a) Use capital letters and English language only. b) Bidder to submit it duly signed and stamped on each page, as a token of their acceptance and confirmation(s) in respect of RFQ. c) Bidder to note that fill in the blanks- data / details is to be entered by the bidder and correct option ticked in respect of Sl. Nos. 1,2,3,4,11,12 and 13 (the same are also highlighted in shaded grey in the table below). d) Bidders are required to carefully fill their responses to below points along with submission of relevant documentary evidence as per the provisions of RFQ. e) In case the responses are incomplete/ inconsistent and / or not substantiated by relevant document(s) the bidders are at risk of evaluation of their bid being concluded without affording them another opportunity to complete / correct / comply their submission with respect to RFQ requirements. In such a case EIL/ Owner reserves the right to complete the evaluation based on the available information and EIL/ Owners decision shall be final and binding.

SL. NO.	DESCRIPTION	BIDDER'S / SUPPLIER'S CONFIRMATION <small>(Strike out response which is not applicable)</small>
1.	a) Bidder/Supplier Name	
	b) Status of Bidder's Firm: Proprietorship/ Partnership/ Limited Liability Partnership / Public Ltd./ Pvt Ltd./ Govt Deptt./ PSU/ Others (Specify)	
	c) Supplier's Offer Ref No.& Date	
2.	Bidder's/ Supplier's authorized signatory's: a) Name: b) Tel. No.: c) Mob. No.: d) E-mail: e) Address (on which order is to be placed): <i>Note: Bidder to ensure that the Address mentioned here shall be in line with the GST Certificate and Vendor enlistment in EIL (applicable for limited enquiries)</i>	
3.	a) Specify Despatch Point b) GSTIN no.	a) b) In case different despatch points are applicable, specify use same as under:-

BIDDER'S NAME AND SIGNATURE WITH STAMP/SEAL

SL. NO.	DESCRIPTION	BIDDER'S / SUPPLIER'S CONFIRMATION (Strike out response which is not applicable)																				
4.	Rate of GST	GST Rate (in %) _____ [If a single rate of GST is applicable] If different rates of GST are applicable, specify the GST rates in the table below: <table border="1" data-bbox="1054 524 1449 1144"> <thead> <tr> <th>Description</th> <th>GST rate in %</th> </tr> </thead> <tbody> <tr> <td>Supply & Freight</td> <td></td> </tr> <tr> <td>Site Work</td> <td></td> </tr> <tr> <td>3D Modelling</td> <td></td> </tr> <tr> <td>Supervision of E/T/C & PGTR</td> <td></td> </tr> <tr> <td>Hazop Study</td> <td></td> </tr> <tr> <td>Training at OEM/Vendor Works</td> <td></td> </tr> <tr> <td>Training at Site</td> <td></td> </tr> <tr> <td>PWAMC</td> <td></td> </tr> <tr> <td>Any other (Please indicate nature)</td> <td></td> </tr> </tbody> </table>	Description	GST rate in %	Supply & Freight		Site Work		3D Modelling		Supervision of E/T/C & PGTR		Hazop Study		Training at OEM/Vendor Works		Training at Site		PWAMC		Any other (Please indicate nature)	
Description	GST rate in %																					
Supply & Freight																						
Site Work																						
3D Modelling																						
Supervision of E/T/C & PGTR																						
Hazop Study																						
Training at OEM/Vendor Works																						
Training at Site																						
PWAMC																						
Any other (Please indicate nature)																						
5.	Confirm that quoted prices are strictly as per Price Schedule format of the RFQ Document and following has been quoted in the Priced Part as per applicability in RFQ/Price Schedule: <ul style="list-style-type: none"> a) Supply on FOT dispatch point basis b) Mandatory Spares (wherever sought separately) c) Site Work d) Transportation e) 2 years O&M Spares f) Unit Rates for Addition/ Deletion g) Unit rates for specific test h) 3D Modelling i) Hazop Study j) Rates for Supervision of E/T/C & PGTR/ Training at Site/3D Modelling/Hazop Study k) Training at Vendor/OEM Works l) Overtime Rates for Supervision of E/T/C & PGTR m) PWAMC 	Confirmed																				
6.	Confirm that quoted prices will remain firm and fixed (except where price escalation/variation is allowed in the	Confirmed																				

BIDDER'S NAME AND SIGNATURE WITH STAMP/SEAL

SL. NO.	DESCRIPTION	BIDDER'S / SUPPLIER'S CONFIRMATION (Strike out response which is not applicable)
	RFQ) till complete execution of the order.	
7.	Confirm that firm transportation charges have been quoted in Price part. In case the same are not quoted in price part the Supply price shall be deemed to include the freight.	Confirmed
8.	Confirm that the offer is valid for the period specified in RFQ/BDS, from the final 'Bid Due Date'.	Confirmed
9.	Confirm submission of EMD/Bid Security (As applicable) as per provision of RFQ.	Confirmed
10.	Bidder's Undertaking Regarding Sharing Land Border with India: (Form-I A, II, whichever applicable) Format for Undertaking is appended with Annexure-II to ITB.	Submitted
11.	a) Bidder confirms that they are not on Holiday/Blacklist/Negative/Suspension/ Banning list of EIL/PLL as on date of submission of our bid.	Confirm / Not Confirm Note: In case response is not marked, "Confirm" shall be considered as Bidder's response
	b) Bidder confirms that they are not banned or delisted or black listed by any government department/ Government or Quasi Government agencies/ public sector as on date of submission of our bid.	Confirm / Not Confirm Note: In case response is not marked, "Confirm" shall be considered as Bidder's response
	c) Bidder confirms that they are not under liquidation, court receivership or similar proceedings.	Confirm / Not Confirm Note: In case response is not marked, "Confirm" shall be considered as Bidder's response
12.	a) Bidder confirms that they are not involved in any Litigation / Arbitration.	a) Confirmed / Not Confirmed Note: In case response is not marked, "Confirmed" shall be considered as Bidder's response
	b) In case response to a) above is 'Not Confirmed', Bidder hereby confirm that the current Litigation / Arbitration, in which they are involved will not have any impact in work being tendered or in entering into contract during the validity of offer and performing the contract till all the contractual obligations under contract are performed.	b) Confirmed / Not Confirmed

BIDDER'S NAME AND SIGNATURE WITH STAMP/SEAL

SL. NO.	DESCRIPTION	BIDDER'S / SUPPLIER'S CONFIRMATION (Strike out response which is not applicable)
13.	Bidder confirms that: a) None of Directors (in Board of Director) of Bidder is a relative of any Director (in Board of Director) of PLL/ EIL OR b) The bidder is not a firm in which any Director (in Board of Director) of PLL/EIL or their relative is a partner.	a) Confirmed /Not Confirmed b) Confirmed / Not Confirmed If response is marked as "Not Confirmed", then provide relevant details..... <i>Note: In case response is not marked, "Confirmed" shall be considered as Bidder's response</i>
14.	Bidder confirms that there is no conflict of interest with other bidders, as per provisions of RFQ Document.	Confirmed
15.	We confirm that the content of the Bidding Document including Price schedule/ prices and Corrigendum / Addendum (if any) have not been altered or modified.	Confirmed
16.	Integrity Pact (if applicable as per IFB/LIB/RFQ): Bidder confirms that they comply with the provisions of Integrity Pact (IP) and have submitted IP duly signed and stamped. In respect of Integrity Pact (IP), Bidder confirms that: a) They have submitted the IP duly signed by authorised POA holder of the Bidder. b) IP is signed on all the pages. c) IP is signed by two witnesses. d) In case of 'Proprietorship firm', IP is signed by the Proprietor. e) In case of Partnership firm, IP is signed by atleast two partners of the firm. f) The correct name and number of RFQ is mentioned in the IP	Confirmed
17.	Bank Mandate We hereby undertake to submit the Bank mandate Form (refer elsewhere for format) along with first invoice/ bill submission, duly filled and certified by bank along with cancelled cheque. In case the same is not submitted along with first invoice, the subsequent date of submission of mandate form shall be considered as the date of invoice submission.	Confirmed
18.	Compliance to RFQ Documents We hereby agree to fully comply with, abide by and accept the RFQ/Enquiry documents including but not limited to	Confirmed

BIDDER'S NAME AND SIGNATURE WITH STAMP/SEAL

SL. NO.	DESCRIPTION	BIDDER'S / SUPPLIER'S CONFIRMATION (Strike out response which is not applicable)
	technical, commercial and other conditions including submission of CPBG within 30 days from date of LOA, technical specifications including general/ technical notes and scope of supply/work including documentation as per material requisition (MR) and subsequent technical/commercial amendment, if any, and technical/commercial corrigendum, if any, without any variation, deviation or reservation.	
19.	Bidder understands that being a "Zero Deviation" bidding & in the case of submission of deviations, the evaluation of bid shall be done as per provisions of RFQ and the bid is liable for rejection.	Confirmed
20.	All commercial terms / compliance / salient details are given /confirmed in this ATC and not elsewhere in the Offer. Bidder to note that the terms and conditions mentioned elsewhere in their offer or Printed terms and conditions of the bidder, if any, appearing in quotation/offer, Bidder's own terms and conditions shall not be given cognizance of.	Confirmed

DECLARATION BY THE BIDDER:

We further confirm that the above declaration/confirmation (including the pre-filled / default response to be considered in case relevant option is not ticked/ not filled) are true and correct in all respects and not in conflict with the declaration mentioned in any part of our bid /any other document. In case of contradiction, the confirmation given herein by the bidder shall prevail over the declaration/ statement/ confirmation given in other places by the Bidder.

We also declare that in case, at a later date, if the above declaration(s) / confirmation(s) submitted in our bid are found to be false, bidder shall be held responsible for the same and EIL/Owner has every right to take action against the bidder / company, as deemed fit as per law of the land and provisions of RFQ Document and EIL/Owner's right to put our Company on Suspension/Banning list for future business with EIL/Owner.

BIDDER'S NAME AND SIGNATURE WITH STAMP/SEAL

**INSTRUCTIONS
TO
BIDDER**

**FOR PDH PP PLANT WITH ETHANE AND
PROPANE HANDLING FACILITIES AT
DAHEJ PROJECT
(EIL JOB NO: B862)**

For Composite Bidding

TABLE OF CONTENTS

A	GENERAL	4
1.0	SCOPE OF BID	4
2.0	CORRUPT AND FRAUDULENT PRACTICES	5
3.0	ELIGIBLE BIDDERS	5
B	CONTENTS OF BIDDING DOCUMENT	7
4.0	BIDDING DOCUMENT	7
5.0	CLARIFICATION OF BIDDING DOCUMENT	8
6.0	AMENDMENT OF BIDDING DOCUMENT.....	8
7.0	ACKNOWLEDGEMENT & CONFIRMATION	8
C	PREPARATION OF BIDS	9
8.0	COST OF BIDDING.....	9
9.0	ZERO DEVIATION:	9
10.0	LANGUAGE OF BID.....	9
11.0	DOCUMENTS COMPRISING THE BID	9
12.0	TECHNO-COMMERCIAL BID	9
13.0	ALTERNATIVE OFFER / MULTIPLE BIDS	10
14.0	BID PRICES AND DISCOUNTS.....	10
15.0	CURRENCIES OF BID AND PAYMENT.....	11
16.0	PERIOD OF VALIDITY OF BIDS	11
17.0	FORMAT AND SIGNING OF BID.....	11
D	SUBMISSION AND OPENING OF BIDS	13
18.0	DEADLINE FOR SUBMISSION OF BIDS	13
19.0	LATE BIDS	13
20.0	WITHDRAWAL, SUBSTITUTION, AND MODIFICATION OF BIDS	13
21.0	BID OPENING	14
E	EVALUATION AND COMPARISON OF BIDS	14
22.0	CONFIDENTIALITY AND COMMUNICATION PROTOCOL	14
23.0	DEVIATIONS, RESERVATIONS, AND OMISSIONS	14
24.0	DETERMINATION OF RESPONSIVENESS	15
25.0	CLARIFICATION OF BIDS	16
26.0	EVALUATION OF TECHNO-COMMERCIAL BIDS.....	16
27.0	CORRECTION OF ARITHMETICAL ERRORS	16
28.0	EVALUATION AND COMPARISON OF PRICE BIDS	17
29.0	OWNER/EIL'S RIGHT TO ACCEPT ANY BID, AND TO REJECT ANY OR ALL BIDS	17
F	AWARD OF CONTRACT	17
30.0	AWARD CRITERIA	17
31.0	REVERSE AUCTION: NOT APPLICABLE.....	18
32.0	SITUATIONS IN WHICH THE AWARD CAN BE RESORTED TO L2 BIDDER	18
33.0	NOTIFICATION OF AWARD	18
34.0	CONTRACT PERFORMANCE BANK GUARANTEE.....	18
35.0	PROCUREMENT FROM A BIDDER FROM A COUNTRY SHARING LAND BORDER WITH INDIA	19
36.0	NON-APPLICABILITY OF ARBITRATION CLAUSE IN CASE OF BANNING OF VENDORS/SUPPLIERS/CONTRACTORS/BIDDERS/CONSULTANTS INDULGED IN FRADULENT/COERCIVE PRACTICES	19
37.0	PROCEDURE FOR ACTION IN CASE CORRUPT/ FRAUDULENT/COLLUSIVE/ COERCIVE PRACTICES.....	19

38.0 COMPLIANCE OF PLL INSIDER’S TRADING:.....20

A GENERAL

1.0 SCOPE OF BID

1.1 In connection with the Invitation for Bids/ Letter Inviting Bid, Engineers India Limited on behalf of Petronet LNG Limited (Petronet LNG Petrochemical Project) invites e-Bid(s), under single stage single bid system for the entire scope of supply covered under the Bidding Document.

1.2 Throughout the Bidding Document:

- (a) Owner/Buyer/Purchaser means Petronet LNG Limited (PLL), a company having its registered office at 4th Floor, Tower I, World Trade Centre, Nauroji Nagar, New Delhi, 110 029, India.
- (b) EIL means Engineers India Limited, a company incorporated under the Companies Act, 1956 having its registered office at 1, Bhikaiji Cama Place, R.K Puram, New Delhi-110066 (INDIA), acting as a Consultant for the Project.
- (c) except where the context requires otherwise, words indicating the singular also include the plural and words indicating the plural also include the singular and word written in capital or small letter or where the first letter is capital have the same meaning.
- (d) “day” means calendar day.
- (e) E-Tendering website (or e-procurement CPP portal / CPPP/ E-tendering system/ e-Procurement Portal/ e-tendering portal) means online portal on which Bidders are required to submit their bid. For this RFQ, e tendering website is <https://eprocure.gov.in/eprocure/app>
- (f) Unless mentioned otherwise, the term ‘Bid Due Date’ shall mean the ‘Final Bid Due Date’.
- (g) “Instructions to Bidders” shall mean the documents describing the manner in which Bidder shall prepare and submit his bid.
- (h) The term “bid”/ “tender” / “offer” / “proposal” and their derivatives (“RFQ/Bidding/Enquiry” documents, “bidder/tenderer”, “Vendor/Supplier/Seller”, “Bid/tender”, “bidding/tendering”, “Contract/Purchase Order” etc.) are synonymous.
- (i) “Tender Document” or “Bidding Document” shall mean the documents issued to the bidder and/ or uploaded on tender portal, including any subsequent addenda to enable bidder submit his Bid.
- (j) “Bidder” or “Tenderer” shall mean the person or company who receives the Tender Document and submits Tender or Bid to EIL either in response to Limited tendering or Open tendering.
- (k) Material Requisition (MR) means the Technical Part of RFQ Document.
- (l) **INCOTERM 2020:** INCOTERM 2020 means the terms which shall be applicable for procurement of equipment/material under the subject RFQ / Enquiry document.
- (m) BoQ/ Price Schedule (PS) / Schedule of Rate (SOR)/ Schedule of Prices (SOP) shall have the same meaning.

The successful bidder / "supplier" shall complete the Scope of RFQ within the Time Period/Completion Period stated in RFQ document.

2.0 CORRUPT AND FRAUDULENT PRACTICES

- 2.1** The Owner requires that Bidders/ Vendors/ Supplier observe the highest standard of ethics during the award/ execution of Contract. "Fraudulent Practice" means a misrepresentation of facts in order to influence the award of a Contract to the detriment of the Owner, and includes collusive practice among bidders (prior to or after bid submission) designed to establish bid prices at artificial non-competitive levels and to deprive the owner of the benefits of free and open competition.
- 2.2** The Owner will reject a proposal for award if it determines that the bidder recommended for award has engaged in fraudulent practices in competing for the Contract in question.
- 2.3** Bidder is required to furnish the complete and correct information/ documents required for evaluation of their bids. If the information/ documents forming basis of evaluation is found to be false/ forged, the same shall be considered adequate ground for rejection of bids and forfeiture of Bid Security.
- 2.4** In case, the information/ document furnished by the Bidder/ Vendor/ Supplier forming basis of evaluation of his bid is found to be false/ forged after the award of the contract, Owner shall have full right to terminate the contract and get the remaining job executed at the risk & cost of such Bidder/ Vendor/ Supplier without any prejudice to other rights available to Owner under the contract such as forfeiture of CPBG, withholding of payment etc.
- 2.5** In case, this issue of submission of false documents comes to the notice after execution of supply/work, Owner shall have full right to forfeit any amount due to the Bidder/ Vendor/ Supplier along with forfeiture of CPBG furnished by the bidder/vendor/ Supplier.
- 2.6** Further, such bidder/ vendor/ Supplier shall be put on Blacklist/ Holiday/ Negative Suspension/Banning List of Owner debaring them from future business with EIL/Owner for a time period, as per the prevailing policy in Owner/EIL.
- 2.7** EIL, being the Consultant for the Owner in this Project reserves the right to take action against the defaulting Bidder/supplier/contractor in this tender/PO/ Contract including putting the Bidder/supplier/contractor on the Suspension/ Banning list of EIL. For this purpose, EIL may decide the same considering the communications carried out by the client with the Bidder/supplier/ contractor (including show cause notice/ personal hearing, etc).
- 2.8** In case any bidder is found to be involved in cartel formation/ bid-rigging /collusive bidding, his bid will not be considered for evaluation/ placement of order. Such bidder will also be debarred from bidding in future.
- ## **3.0 ELIGIBLE BIDDERS**
- 3.1** An Eligible bidder may be a firm or a company, who, have been issued/intimated for issuance of RFQ on Limited Competitive Basis
- 3.2** A bidder who is on **Black-listing / Holiday Listing /Suspension / Banning List/ Negative List** of EIL/PLL as on due date of submission of bid / during the process of evaluation of the bids, the offers of such bidders shall not be considered for bid opening/evaluation/award.

- 3.3** Bidder should be not under Liquidation, Court receivership or similar proceedings. Bidder to submit self-certificate in this regard.

In case Bidder(s) affirms that present litigations/arbitrations have impact on their obligations to perform the Contract or doesn't provide the affirmations as above, their bids shall be rejected.

Note: In case it comes to the notice of PLL/EIL that the bidder has given wrong declaration in this regard, the same shall be dealt as 'fraudulent practices' and action shall be initiated as per the procedure for action in case of corrupt / Fraudulent / collusive / coercive practices.

- 3.4** Bidder to comply the guidelines of Department of Expenditure (DOE) vide O.M. No. 7/10/2021-PPD (1) dated 23.02.2023 for Restriction on procurement from Bidders from Country(ies) sharing Border with India. Refer Cl. No. 35 of this ITB for details.

- 3.5** The bidder found to have a conflict of interest shall be disqualified.

Bidder's conflict of interest as Consultant of EIL/ Owner:

Consultants or any of their Affiliates will not be considered for any assignment, which by its nature may be in conflict with another assignment of the consultants.

Bidder's conflict of interest with other bidders:

A bidder shall not have conflict of interest with other bidders. Such conflict of interest can lead to anti-competitive practices to the detriment of Owner's interests. The bidder found to have a conflict of interest shall be disqualified

A bidder may be considered to have a conflict of interest with one or more parties in this bidding process, if:-

- a. they have controlling partner(s) in common; or
 - b. they receive or have received any direct or indirect subsidy/ financial stake from any of them; or
 - c. they have the same legal representative/agent for purposes of this bid; or
 - d. they have relationship with each other, directly or through common third parties, that puts them in a position to have access to information about or influence on the bid of another Bidder; or.
 - e. Bidder or any of its affiliates participated as a consultant in the preparation of the design or technical specifications of the contract that is the subject of the Bid;
 - f. In case of a holding company having more than one independently manufacturing units, or more than one unit having common business ownership/management, only one unit should quote. Similar restrictions would apply to closely related sister companies. Bidders must proactively declare such sister/ common business/ management units in same/ similar line of business.
- 3.6** The Bidder shall not be under a declaration of ineligibility by Purchaser for Corrupt/ Fraudulent/ Collusive/ Coercive practices, as defined elsewhere.

B CONTENTS OF BIDDING DOCUMENT

4.0 BIDDING DOCUMENT

4.1 The RFQ document consisting of Commercial & Technical Section has been hosted on e-procurement website (i.e. <https://eprocure.gov.in/eprocure/app>). However, a link shall be provided in EIL website <http://tenders.eil.co.in>.

4.2 The Bidding Document shall in general consist of the following and should be read in conjunction with any amendment issued in accordance with Clause No. 6 of ITB.

- Request for Quotation (RFQ).
- Bid Data Sheet
- Instructions to Bidders and its attachments/annexure.
- Bidding Forms
- Format for Performance Bank Guarantee and Bank Guarantee for Advance
- Packing, Marking, Shipping and Documentation Specification
- Additional Documents Mentioned in RFQ / BDS
- General Conditions of Contract (GCC) for Goods.
- Special Purchase Conditions (SPC) and its Annexure.
- Schedule of Rates (SOR)/ Schedule of Prices (SOP).
- **Material Requisition (MR)** comprising Scope details, data sheet, Technical Specifications / Standards, Drawings, if any Drawings, if any

4.3 Although all the details presented in this Bidding Document have been compiled with reasonable care, the bidder is expected to examine the Bidding Document, including all instructions, forms, terms, specifications and drawings in the Bidding Document and it includes all the documents as per Table of Contents. In case of any ambiguity or incompleteness, the bidder must bring it to the attention of EIL immediately and prior to submission of Bid.

4.4 The bidder is expected to examine the RFQ document downloaded from the e-Procurement Portal, bidding guidelines receipt from EIL or available on EIL website, all instructions, formats, terms, specifications and drawings etc., enclosed in the RFQ documents. The invitation for bid (bidding) together with all its attachment thereto, shall be considered to be read, understood and accepted by the bidder in co-ordination to each other. Failure to furnish all information required by the RFQ documents or submission of a bid not substantially responsive to the RFQ documents in every respect will be at bidder's risk and may result in the rejection of the Bid.

4.5 Without prejudice to provisions indicated elsewhere, Bidding document once issued in case of limited competitive bidding is non-transferable.

4.6 Order of precedence

The documents forming the Purchase Order are to be taken as mutually explanatory of one another. If there is an ambiguity or discrepancy in the Term & Conditions defined in the various documents, the order of Precedence shall be as follows:

- i. Purchase Order and its enclosures along with Purchase Requisition

- ii. Amendment to Bidding Document, if any
- iii. Bid Data Sheet (BDS)
- iv. Job Specifications
- v. Drawings
- vi. Technical specifications
- vii. Special Purchase Conditions (SPC)
- viii. General Conditions of Contract (GCC) for Goods & Packing, Marking, Shipping and Documentation Specification
- ix. Request for Quotation (RFQ)/Invitation for Bids (IFB)
- x. Instructions to Bidders (ITB)
- xi. Other Documents

A variation or amendment issued after the execution of the formal contract shall take precedence over respective clauses of the formal contract and it's Annexures.

5.0 CLARIFICATION OF BIDDING DOCUMENT

- 5.1** Enquiry is issued on "Zero Deviation Bid" basis wherein no post bid correspondence of any nature may be entertained accordingly no CQ/ TQ on withdrawal of deviations shall be issued in general, and evaluation shall be completed based on the bids submitted. Wherever it is decided to issue the CQ/TQ, minor clarifications/shortfall of information/ supporting documents only from the lowest bidder(s) (acceptable otherwise) or recommended bidder(s) which do not impact the prices of the bidder, may be sought to ensure compliance of the zero deviation.

6.0 AMENDMENT OF BIDDING DOCUMENT

- 6.1** At any time prior to the deadline for submission of bids, EIL may, for any reason whether at his own initiative or in response to the clarification requested by the prospective bidder(s), issue amendment in the form of Amendment/ Addendum/Corrigendum.
- 6.2** Any addendum issued shall be part of the Bidding Documents and shall be uploaded on e-procurement CPP portal.
- 6.3** To give bidders reasonable time in which to take an addendum into account in preparing their bids, EIL may extend the deadline for the submission of bids, pursuant to Clause 18.2 of ITB.
- 6.4** Deleted.

7.0 ACKNOWLEDGEMENT & CONFIRMATION

- 7.1** Within 3 days of downloading of Bidding Document, bidder shall acknowledge and confirm his intention to bid for the tendered work on EIL website <http://tenders.eil.co.in>.
- 7.2** Bidders should respond to this enquiry either by submitting their bids or chooses to regret by explaining the reason for non-submission of the offer. In case there is no response either way continuously, the bidder may be liable for suitable action including review of their enlistment with EIL for that particular item.

C PREPARATION OF BIDS

8.0 COST OF BIDDING

Bidder shall bear all costs associated with the preparation and submission of their Bid, and PLL/EIL shall not be responsible or liable for those costs, regardless of the conduct or outcome of the bidding process.

9.0 ZERO DEVIATION:

9.1 Bidders to note that enquiry is issued on Zero deviation basis. Bids are to be submitted on Zero deviation basis and in strict compliance with the terms & conditions, scope, specifications and other stipulations contained in the tender/ enquiry without any deviations.

9.2 In view of this Bidder shall ensure submission of complete bid without any deviation as per requirement of Bidding Document in first instance itself.

10.0 LANGUAGE OF BID

10.1 The Bid, as well as all correspondence and documents relating to the bid exchanged by the bidder and EIL/Owner, shall be in the English language. Supporting documents and printed literature that are part of the Bid may be in another language provided they are accompanied by an accurate translation of the relevant passages in the English language, in which case, for purposes of interpretation of the Bid, such translation shall govern.

10.2 In the event of submission of any document/ certificate by the bidder in a language other than English, the bidder shall get the same translated into English. The English translation copy of the same shall also be furnished duly certified, stamped and signed by Local Chamber of Commerce or Indian Embassy in their country or their Embassy in India or any translator in India recognized / authorized by their Embassy.

11.0 DOCUMENTS COMPRISING THE BID

Electronic Bids (e-bid) Techno-commercial part including priced part as detailed below shall be submitted in first instance through e-tendering portal in accordance with the instructions and terms & conditions enclosed with the Bidding Document.

12.0 TECHNO-COMMERCIAL BID

(a) Power of Attorney and/or Board Resolution in favour of authorised bid signatory

Note: All documents files of the bid shall be e signed and uploaded by using the digital signature issued in the name of person having valid POA at the time of bid submission.

(b) Agreed Terms & Conditions for Indigenous Bidder

(c) Bank Mandate Form with cancelled cheque duly signed and stamped with the Banker's certification as per **Form-A**;

(d) Signed and stamped copy of Form-IA/II, as applicable (on Company's Letterhead) attached with Annexure-II of ITB in line with Government guidelines regarding procurement from bidders from a country or countries sharing Land Border with India;

(e) Price Schedule with prices filled in. The rates are to be filled in accordance with instructions provided in Preamble to Schedule of prices, in e-tendering portal, without making any changes in the format/names of the file/worksheet.

(f) Amendment /addendum (if any);

(g) any other document **required as per, Technical Specifications; and**

(h) any other document **required in the BDS.**

In case of any conditions stipulated in price bids, the bids of such bidders shall be summarily rejected and shall not be considered for further evaluation. Evaluation shall be carried out excluding such bidder(s.)

Note:

a) Duly filled Price Schedule/BOQ shall be uploaded in “FINANCE” folder in e-tendering portal.

b) The prices as submitted in the price part only shall be considered for evaluation and ordering, if any. If prices are not found in the format of Price Schedule/BoQ and even if mentioned elsewhere, the bid shall be rejected.

13.0 ALTERNATIVE OFFER / MULTIPLE BIDS

A bidder (i.e., the bidding entity) shall, on no account submit more than one bid either directly (as a single bidder) or indirectly (as a sub-contractor) failing which bid shall be rejected.

14.0 BID PRICES AND DISCOUNTS

14.1 The prices must be quoted strictly in the format of Price Schedule/BoQ provided in the Bidding Document. Bidder shall not quote any discount separately for any item or on overall price. Conditional discount, if offered, shall not be considered for evaluation.

14.2 Unless stated otherwise in the Bidding Document, the Contract shall be for the total works as described in Bidding Document, based on the Schedule of Rates/ Price schedule submitted by the bidder and accepted by EIL.

14.3 Rates/ prices quoted by the bidder, shall remain firm, fixed and valid till the completion of the Works and will not be subject to variation on any account except as otherwise specifically stated in the Bidding Documents.

14.4 It shall be the responsibility of the Bidder to duly enquire of their own and comply with all applicable laws, rules, regulations, orders and formalities applicable to Goods and Services Tax (GST), Custom Duty etc. on the manufacture, sale and/or supply of any material / services to Owner / EIL. It is clearly understood that Owner/ EIL will not have any additional liability towards payment of applicable Taxes & Duties as a result of Bidder's wrong assessment / interpretation of applicable taxes & duties.

14.5 All duties, taxes, and other levies payable shall be as per Annexure-II of Special Purchase Conditions.

14.6 The Bidder shall keep the Owner / EIL indemnified from and against any and all claims, demands, prosecutions, penalties, damages, demurrages and/or other levies whatsoever made or levied by any Court, Tribunal or the Customs or other Authorities with respect to any alleged breach, evasion or infraction of such duties, taxes, charges or levies or any breach or infraction of such laws, rules, regulations, orders or formalities concerning the same and from the consequence thereof.

15.0 CURRENCIES OF BID AND PAYMENT

Currency of bid and payment shall be made in INR only.

16.0 PERIOD OF VALIDITY OF BIDS

16.1 Bids shall remain valid for the period specified in the **RFQ/BDS** after the bid submission deadline date prescribed by EIL in accordance with Clause 18.0 of ITB. A bid with shorter validity shall be rejected by EIL as non-responsive. Bidders shall not be entitled during the above period, without the consent of EIL in writing, to revoke or cancel their Bid or to vary the Bid given or any term thereof. In case of bidders revoking or cancelling their Bid or varying any terms in regard thereof without the consent of EIL/Owner in writing, EIL/Owner shall forfeit Bid security, submitted along with the bid and shall reject their bids. Such Bidder may also be put on Black list / Holiday list/ Negative List/Suspension/Banning List.

16.2 In exceptional circumstances, prior to the expiration of the bid validity period, EIL may request bidders to extend the period of validity of their bids. The request and the responses shall be made in writing.

17.0 FORMAT AND SIGNING OF BID

17.1 Bids shall be signed by the authorized signatory of the bidder.

17.2 Bidder shall submit a Power of Attorney in favour of authorized bid signatory(ies) and Digital signatory.

17.3 For Indian Bidder, POA shall be on non-judicial stamp paper of minimum value of INR 100/- and duly Notarized by a Notary Public in India.

For Foreign Bidders, POA shall be:

- on the Stamp Paper of appropriate value or engraving/embossing, in lieu of nonjudicial stamp paper, as per applicable laws in Bidder's Country; or
- as per any other system prevailing in the bidder's country for the purpose of issuing POA.

17.4 Requirements for submitting the Power of Attorney (POA) shall be as follows:

i) Company:

- Bidder shall submit a specific Power of Attorney for the enquiry in the name of authorized person. OR
- In case Bid signatory has General Power of Attorney or has the power as per their Board resolution, the same shall be submitted duly certified by Notary Public or CEO/CFO/Company Secretary (CS)/Member of Board of Directors. OR

- In case, Bid is signed by CEO/CFO/CS/any member of board of Directors, no separate POA is required, provided the documentary evidence of their being CEO/CFO/CS/any member of board of Directors is reflected in the MOA/AOA/Financial Statements, else submitted separately in the Bid.
- ii) Partnership Firm: In such case,
- Bid can be signed by all the partners of the Firm and in such case no separate POA is required. OR
 - Bid can be signed by any of the Partner(s) holding Power of Attorney as specified in the Partnership Deed, OR
 - Bid can be signed by an authorized person and shall submit a specific POA for the Enquiry duly signed by all the Partners.
- Bidder shall submit the copy of Partnership Deed.
- iii) Limited Liability Partnership (LLP) Entity: Bid shall be signed by the person
- holding Power of Attorney as per the registered LLP Agreement for the Firm, OR
 - has the power as per their Board resolution, OR,
 - having a specific POA for the Enquiry duly signed by all the LLP Partners.
- Bidder shall submit (i) a copy of LLP Agreement, and (ii) a copy of Certificate of Incorporation.
- iv) Proprietorship: Proprietor shall sign the Bid. Bidder shall also submit a copy of (i) PAN card and (ii) Bank Mandate Form, duly certified by the Bidder's Banker.
- v) Specific POA issued for the Enquiry shall confirm that the authorized signatory have been authorized to do in the name and on behalf of the Company/Firm all or any of the acts, deeds or things necessary in connection with or incidental to the Bid submitted by the bidder for the subject Enquiry Document, including but not limited to the signing and submission of bid, participating in the meetings, responding to queries, submission of information / documents and generally to represent us in all the dealings with EIL/Owner or any person, in connection with the works, without any prejudice, limitations and exceptions till the completion of the bidding process.
- 17.5** Bidders to upload the Un-price and Price part of their e-bids strictly in the Un-price & Priced folders respectively at the designated place in the e-tendering portal.
- 17.6 DIGITAL SIGNATORY:**
- i) The e-bid shall be digitally signed (e-signed) using the digital signature of a person duly authorized to sign on behalf of the bidder. The digital signature used for signing the bid shall be issued in the name of such authorized person and the certificate details, available from the signed documents, should indicate the details of the signatories. Any consequences resulting due to such signing (e-signing) shall be binding on the bidder.
- ii) All documents as submitted in the e-Procurement Portal using digital signature at any time during the Bidding process shall be deemed considered signed by the

authorized signatory only, irrespective of authorized signatory's signature on all pages or not.

D SUBMISSION AND OPENING OF BIDS

18.0 DEADLINE FOR SUBMISSION OF BIDS

18.1 Bidders shall submit their bids electronically in the e-tendering portal, within the date and time **specified in the RFQ or any extensions thereof**. Bidders submitting bids electronically shall follow the electronic bid submission procedures **enclosed as Annexure-I to this ITB**.

No Physical bid shall be permitted other than submission of the documents categorically asked for in hard copies as part of e-bids submitted online through the e-tendering Portal. The bids submitted online through e-tendering Portal shall only be considered for evaluation and ordering. The e-bid must be complete in all respects, leaving no scope for ambiguity. Bidder shall be fully responsible for the bid submitted in e-tendering portal and no relief or consideration can be given for errors and omissions.

18.2 EIL/Owner may, at its discretion, extend the deadline for the submission of bids by amending the Bidding Documents in accordance with Clause 6.0 of ITB, in which case all rights and obligations of EIL/Owner and bidders previously subject to the deadline shall thereafter be subject to the deadline as extended.

18.3 Bidder should avoid the last hour rush to the website wherein bidder is likely to miss the deadline for bid submission. Due date extension request due to above reason shall not be entertained.

19.0 LATE BIDS

19.1 E-tendering system shall close immediately after the deadline for submission of bid.

19.2 Unsolicited bids or bids being submitted to place/website other than one specifically stipulated in the RFQ documents shall not be considered for opening/evaluation/award.

20.0 WITHDRAWAL, SUBSTITUTION, AND MODIFICATION OF BIDS

20.1 The bidder may modify, re-submit or withdraw its e-bid after the bid submission, but, before the due date and time for submission of Bid following the electronic bid submission procedures.

There are two specific features in NIC- Central Public Procurement Portal (CPPP) viz, "Withdraw" and "Re-Submission". Bidders should not use the feature "withdraw" unless they have decided to withdraw their bids. It is to be noted that once "withdraw" feature is used they will not be allowed to re-submit their bid against this Bidding Document. In case a Bidder desires to change his bid for any reason before bid due date, Bidder shall use "Re-Submission" feature.

20.2 No bid shall be withdrawn, substituted, or modified in the interval between the deadline for submission of bids and the expiration of the period of bid validity or any extension thereof.

20.3 In case bidder fails to accept the order or withdraw the bid after bid submission, punitive action shall be taken against them as per the EIL/ Policy.

21.0 BID OPENING

- 21.1** EIL shall open bids received in the e-tendering portal except bidders who are on Holiday/ Suspension / Banning list of EIL / PLL.
- 21.2** Unpriced and priced bid shall be opened together in single stage.

E EVALUATION AND COMPARISON OF BIDS**22.0 CONFIDENTIALITY AND COMMUNICATION PROTOCOL**

- 22.1** A bidder may seek clarification regarding the bidding document provisions, bidding process and / or rejection of his bid. EIL shall respond to such requests within a reasonable time. However, such information relating to the evaluation of bids and recommendation of contract award shall not be disclosed to any other persons not officially concerned with the bidding process.
- 22.2** Any attempt by a bidder to influence EIL in the evaluation of the bids or Contract award decisions shall render their Bid liable for rejection.
- 22.3** Notwithstanding Clause 22.2 of ITB, from the time of bid opening to the time of Contract award, if a bidder wishes to contact EIL on any matter related to the bidding process, it shall done so in writing only.
- 22.4** Bidder shall strictly follow the communication protocol as prescribed in BDS/RFQ. In case the queries are not addressed to the persons specified in the communication protocol stipulated in the BDS/RFQ, EIL may not give any cognizance to the same and EIL shall not be liable to reply them.
- 22.5** Only a bidder who has participated in the concerned procurement process i.e. bidding, as the case may be, can make such representation in respect of the procurement process in which they have participated.

Any representation pertaining to Award stage by a bidder whose price bid is opened and is directly affected by such award shall have to submit such representation within 10 days of the issue of LOA.

- 22.6** Following decisions of the EIL/PLL shall not be subject to review
- i) Determination of the need for procurement;
 - ii) Selection of the mode of procurement or bidding system;
 - iii) Choice of selection procedure;
 - iv) Provisions limiting participation of bidders in the procurement process;
 - v) The decision to enter into negotiations with the L1 bidder;
 - vi) Cancellation of the procurement process except where it is intended to subsequently re-tender the same requirements
 - vii) Issues related to ambiguity in contract terms after award of contract.
 - viii) Complaints against specifications except under the premise that they are either vague or too specific so as to limit competition may be permissible.

23.0 DEVIATIONS, RESERVATIONS, AND OMISSIONS

- 23.1** During the evaluation of bids, the following definitions apply:

- (a) "Deviation" is a departure from the requirements specified in the Bidding Documents;

- (b) "Reservation" is the setting of limiting conditions or withholding from complete acceptance of the requirements specified in the Bidding Documents; and
- (c) "Omission" is the failure to submit part or all of the information or documentation required in the Bidding Documents.

24.0 DETERMINATION OF RESPONSIVENESS

24.1 EIL/Owner's determination of a bid's responsiveness is to be based on the contents of the bid itself, as defined in Clause 11.0 of ITB.

24.2 Bids/ offers/ tenders that do not meet the basic requirements specified in the Bidding Document shall be treated as unresponsive and ignored. All tenders received will first be scrutinized to see whether the tenders meet the basic requirements as per the Bidding Document and to identify unresponsive tenders, if any. Unresponsive offers may not subsequently be made responsive by correction or withdrawal of the non-conforming stipulation. Points on the basis of which a tender may be declared as unresponsive and be ignored during the initial scrutiny are:

- i. Bidder is debarred or on holiday or suspension as per the terms specified in the Bidding Document.
- ii. In case contract/ Purchase order awarded for the tendered work have to be terminated due to Contractor's/ supplier's default and a separate enquiry / tender have to be floated to get the remaining/ complete work executed, such defaulting Contractor/ supplier will not be considered for enquiries/ tenders issued for the refloated work/ enquiry.
- iii. In case bidder declares in the bid that they are under liquidation, court receivership or similar proceedings.
- iv. Bidder declares of labour strike or lock-out during the course of evaluation or if it comes to notice of EIL.

After examination of preliminary responsiveness as above, the bids determined as responsive shall be considered for further evaluation and shall be evaluated in detail to examine for any shortfall of information/documents and necessary clarifications may be sought at the sole decision of EIL/PLL.

24.3 In addition to above, in case tender is issued on other than 'Zero Deviation' basis, following provision shall also apply:

A substantially responsive bid is one that meets the requirements of the Bidding Documents without material deviation, reservation, or omission. A material deviation, reservation, or omission is one that,

- (a) if accepted, would:
 - (i) affect in any substantial way the scope, quality, or performance of the Works specified in the Contract; or
 - (ii) limit in any substantial way, inconsistent with the Bidding Documents, EIL's rights or the bidder's obligations under the proposed Contract; or
- (b) if rectified,
 - (i) would unfairly affect the competitive position of other bidders presenting substantially responsive bids.

24.4 Bidder shall not be allowed to submit any Price Implication or Revised Price after submission of e-Bid.

25.0 CLARIFICATION OF BIDS

25.1 Bidders should ensure that the Bid submitted is substantially responsive Bid in the first instance itself. Evaluation may be completed based on the content of the Bid itself without seeking any subsequent additional information which may result in rejection of Bid. However, EIL may, at its discretion, may request bidder to submit the necessary information or documentation, within a reasonable period of time, to withdraw material deviation, reservation, or rectify omission in the bid related to documentation requirements. Requesting information or documentation on such account shall not be related to any aspect of the price of the Bid (forming part of evaluation). EIL's request for clarification and the response shall be in writing.

25.2 No change, including any voluntary increase or decrease, in the prices or substance of the bid shall be sought, offered, or permitted. Bidder shall not be allowed to submit any price implication or revised price after submission of Bid unless the same is called for by EIL in writing.

25.3 Any clarification submitted by a bidder that is not in response to a request by EIL shall not be considered. Failure of the bidder to comply with the request may result in the rejection of its Bid.

25.4 If a bidder does not provide clarifications of its bid by the date and time set in EIL's request for clarification, its bid shall be evaluated with available information which may result in rejection of their bid.

26.0 EVALUATION OF TECHNO-COMMERCIAL BIDS

26.1 Any unsolicited reduction in price offered by a bidder within the bid validity by way of discount or revised prices, subsequent to the bid due date, shall not be taken into account for comparison. However, such reduction in price shall be taken into account for ordering if such bidder happens to be recommended as per the originally quoted prices.

26.2 In case, it is found that some of components of Price schedule viz. Freight Charges, Incidental Services Component, etc. are left blank or quoted "Nil/Zero" in Price Bid, the same shall be considered inclusive in total quoted price for evaluation and ordering. No confirmation from the bidder shall be sought in this regard.

26.3 It is clarified here that for grouped/ basket/ block, if any item not quoted, the offer shall be rejected for that group/ basket/ block without any CQ/ TQ.

27.0 CORRECTION OF ARITHMETICAL ERRORS

The prices quoted by bidders shall be checked for arithmetic correction, if any, based on rate and amount filled by the bidder in the SOR/price schedule/BoQ formats. Based on the format of price schedule/SOR, suitable provisions shall be incorporated in enquiry document as follows:

RATE AND AMOUNT IN FIGURES ONLY

When rate and amount are in figures only, in case of discrepancy, the rate quoted by bidder shall be taken as correct.

In case of any discrepancy, Bidders shall be requested to accept correction of arithmetical errors. Failure to accept the correction may liable for rejection of the Bid.

28.0 EVALUATION AND COMPARISON OF PRICE BIDS

28.1 EIL shall compare the price bids based on the award methodology and loading criteria, if any, provided in **RFQ/BDS** to determine the lowest evaluated bid.

28.2 When price implication is not specifically sought in writing from the bidder and the bidder on his own or any other reason submits the price implication, the same shall be treated as unsolicited price implication.

28.3 Any unsolicited reduction in price offered by a bidder within the bid validity by way of discount or revised prices, subsequent to the bid due date, shall not be taken into account for comparison. However, such reduction in price shall be taken into account for ordering if such bidder happens to be recommended as per the originally quoted prices.

28.4 In the event of any unsolicited price increase sought by any bidder, subsequent to the bid due date, the bid of such a bidder shall be rejected, in case the bidder does not agree to withdraw the price increase and the enquiry shall be refloated. Wherever, decision is taken to reject a bid appropriate action shall be taken as per applicable policy / procedure of EIL.

28.5 Any implication on account of wrong quotation of taxes and duties shall be to Bidder's account. However, the payment towards such taxes and duties quoted by the bidder shall be restricted to lower of taxes and duties quoted by the bidder or the documentary evidence provided by the bidder.

29.0 OWNER/EIL'S RIGHT TO ACCEPT ANY BID, AND TO REJECT ANY OR ALL BIDS

29.1 The PLL/EIL reserves the right to accept or reject any bid, and to annul the bidding process and reject all bids at any time prior to award of the order without thereby incurring any liability to the affected bidder or bidders or any obligations to inform the affected bidder or bidders on the ground of such action by EIL.

F AWARD OF CONTRACT

30.0 AWARD CRITERIA

30.1 Subject to Clause 28.1of ITB, the EIL / Owner shall award the Contract to the bidder who has been determined to be the lowest evaluated bid. However, if in the opinion of Owner, the total price or certain item rates quoted by the lowest evaluated bidder are considered high, Owner may invite such bidder for price negotiation. Lowest quoted bidder shall attend such negotiation meetings and if requested by Owner shall provide the analysis of rates/break-up of amount quoted by him for any or all items of Schedule of Rates/ Prices to demonstrate the reasonability. As a result of negotiation, bidder may offer rebate on his earlier quoted Price.

30.2 In an extreme situation, when there is a 'TIE' based on the evaluated price (after loadings, if any), recourse shall be taken on the basis of Bidder's maximum annual turnover during the last 3 years. For this purpose, annual turnover of the bidders having tie, shall be

tabulated for the past 3 years and maximum annual turnover in any of the last 3 years shall be determined for each bidder. The Bidder whose maximum turnover is highest shall be the recommended Bidder.

31.0 REVERSE AUCTION: NOT APPLICABLE

32.0 SITUATIONS IN WHICH THE AWARD CAN BE RESORTED TO L2 BIDDER

i) Under insolvency or Bankruptcy Bidders shall submit declaration on proceedings under Insolvency and Bankruptcy Code, 2016. Offer will not be considered of bidder(s) in the following cases:

(a) If the bidder is undergoing insolvency resolution process or liquidation or bankruptcy proceedings under Insolvency and Bankruptcy Code, 2016 (Code) or any other applicable law (in cases where code is not applicable).

(b) Insolvency resolution process or liquidation or bankruptcy proceeding is initiated under the Code or any other applicable law (in cases where code is not applicable) against/ by the bidder at any stage of evaluation of the bid.

In case where the bid of the L-1 bidder is rejected on the aforesaid grounds during the period between Price-Bid-Opening and Award of Contract, the bid of the next higher eligible bidder may be considered for further processing subject to matching of L1 bidder's prices.

ii) Treatment of Holiday listed L-1 Bidder: If after opening of price bids, it has come to the notice that the L-1 bidder has already been put on holiday list due to any reason whatsoever at any location within PLL/EIL, the party will not be considered for issue of order, the bid of the next higher eligible bidder may be considered for further processing subject to matching of L1 bidder's prices.

33.0 NOTIFICATION OF AWARD

33.1 Prior to the expiration of the period of bid validity, the Owner shall notify the successful bidder, in writing, that its bid has been accepted. The notification letter (hereinafter called the "**Letter of Award (LOA) / PURCHASE ORDER (PO)**") shall specify the sum that the Owner will pay the Supplier in consideration of the execution and completion of the Supply/Works.

33.2 Copies of LOA / PO shall be submitted back by Supplier duly signed and stamped as a token of their acknowledgement.

34.0 CONTRACT PERFORMANCE BANK GUARANTEE

34.1 Within thirty (30) days of the receipt of notification of award, the successful bidder shall comply with the requirement of Contract Performance Bank Guarantee.

34.2 Failure of the successful bidder to submit the above-mentioned Contract Performance Bank Guarantee or sign the Contract shall constitute sufficient grounds for the annulment of the award and forfeiture of the bid security.

35.0 PROCUREMENT FROM A BIDDER FROM A COUNTRY SHARING LAND BORDER WITH INDIA

Department of expenditure vide OM no. 7/10/2021-PPD (1) DATED 23.02.2023 has issued the Revised Guidelines for Restriction on Procurement from Bidders from Countries sharing Border with India.

In view of the above order, following guidelines are issued for compliance:

- a) Any bidder from a country which shares a land border with India will be eligible to bid in any procurement whether of goods, services (including consultancy services & non-consultancy services) or works (including turnkey projects) only if the bidder is registered with the Competent Authority specified in Annexure-I of the DoE OM dated 23.07.2020 {Public Procurement No.1}.
- b) These orders will not be applicable to the bidders from those countries (even if sharing a land border with India) to which the Government of India has extended lines of credit or in which the Government of India is engaged in development projects.
- c) Updated lists of countries to which lines of credit have been extended or List of countries in which development grant projects are undertaken are given on the website of Ministry of External Affairs.
- d) Bidder shall refer to the enclosed **Annexure-II of ITB.**

Bidders shall submit a certificate of compliance in the enclosed Form I A / II of Annexure-II of ITB.

36.0 NON-APPLICABILITY OF ARBITRATION CLAUSE IN CASE OF BANNING OF VENDORS/SUPPLIERS/CONTRACTORS/BIDDERS/CONSULTANTS INDULGED IN FRADULENT/COERCIVE PRACTICES

Arbitration clause will not be applicable in case of banning of Vendors/suppliers/contractors/bidders/consultants indulged in fraudulent/ coercive practices. Accordingly, the following provision shall be applicable:

“Notwithstanding anything contained contrary in GCC and other sections of Bidding Document, in case it is found that the Vendors/ Suppliers/ Contractors/ Bidders/ Consultants indulged in fraudulent/ coercive practices at the time of bidding, during execution of the contract etc., and/or on other grounds as mentioned in PLL’s “Procedure”, the contractor/bidder/vendor/supplier /consultant shall be banned (in terms of aforesaid procedure) from the date of issuance of such order by PLL., to such Vendors/ Suppliers/ Contractors/ Bidders/ Consultants and PLL has the right to take appropriate legal remedy available to it under the applicable laws. Such disputes shall be governed by the jurisdiction clause of the contract.

37.0 PROCEDURE FOR ACTION IN CASE CORRUPT/ FRAUDULENT/COLLUSIVE/ COERCIVE PRACTICES

Procedure for action in case Corrupt/ Fraudulent/Collusive/Coercive Practices is enclosed with General Conditions of Contract. Further, EIL may also initiate suitable actions against above and procedure for the same is available in EIL website.

38.0 COMPLIANCE OF PLL INSIDER'S TRADING:

By virtue of association / engagement with Petronet LNG Limited (PLL), it is likely that certain Unpublished Price Sensitive Information (UPSI) as defined under "Code for Prevention of Insider Trading in the Securities of PLL" (hereinafter called Code), copy of which is hosted on the website of the company www.petronetlng.in, that is not generally available and which upon becoming generally available is likely to materially affect the price of the securities issued by PLL, might be shared with you / your organization. It is hereby cautioned that you or any of your team members or immediate relatives thereof or your organization, should not trade in the securities of PLL while in possession of such UPSI or communicate such UPSI to any person except in furtherance of legitimate purposes (as defined in the Code), performance of duty or discharge of legal obligations. Any trades in securities of PLL, directly or indirectly, while in possession of any UPSI would be presumed to have been motivated by the knowledge and awareness of the UPSI and the onus to prove that trades were executed otherwise would be on you or any of your team members or your organization as the case may be. It is therefore advised that all concerned as stated above must familiarize himself/themselves with the "Code for Prevention of Insider Trading in the Securities of PLL", copy of which is hosted on the website of the company.

Accordingly, it must be ensured that any UPSI, whenever received from the company:

- (a) shall be used solely for the purpose for which it is being disclosed;
- (b) shall be preserved and the secrecy of such information shall be maintained;
- (c) shall not be disclosed to any third party;
- (d) shall be kept securely and properly protected against theft, damage, loss and unauthorized access (including access by electronic means) by deploying means similar to those being used to secure its own confidential information;
- (e) to notify PLL immediately upon becoming aware that any of the confidential information has been disclosed to or obtained by a third party.

It may be noted that any violation in dealing with UPSI shall be considered as breach of terms of engagement / Contract and PLL shall take necessary action for such breach in addition to reporting to SEBI for taking necessary action under SEBI (Prohibition of Insider Trading) Regulations, 2015 or subsequent amendments thereof. Further, SEBI may take any action including levy of penalty etc. as per SEBI Regulations in this regard in case of any violation in dealing with UPSI at your end.

E-TENDERING METHODOLOGY

Instructions for Online Bid Submission:

The bidders are required to submit soft copies of their bids electronically on the CPP Portal (URL: <http://eprocure.gov.in>) only, using valid Digital Signature Certificates. The instructions given below are meant to assist the bidders in registering on the CPP Portal, prepare their bids in accordance with the requirements and submitting their bids online on the CPP Portal.

More detailed information useful for submitting online bids on the CPP Portal may be obtained at:

<http://eprocure.gov.in/eprocure/app> .

REGISTRATION

- 1) Bidders are required to enroll on the e-Procurement module of the Central Public Procurement Portal (URL: <http://eprocure.gov.in/eprocure/app>) by clicking on the link “Click **here to Enroll**” on the CPP Portal is free of charge.
- 2) As part of the enrolment process, the bidders will be required to choose a unique username and assign a password for their accounts.
- 3) Bidders are advised to register their valid email address and mobile numbers as part of the registration process and submit in EIL tender portal for updation of records (<http://tenders.eil.co.in>) . These details would be used for any communication from the CPP Portal.
- 4) Upon enrolment, the bidders will be required to register their valid Digital Signature Certificate (DSC) (Class II or Class III Certificates with signing key usage) issued by any Certifying Authority recognized by CCA India (e.g. Sify / TCS / nCode / eMudhra etc.), with their profile.
- 5) Foreign Bidders have to refer “DSC details for foreign Bidders” for Digital signature Certificates requirements which comes under Download Tab at <http://eprocure.gov.in/eprocure/app> and the remaining part is same as above and below.
- 6) Only one valid DSC should be registered by a bidder. Please note that the bidders are responsible to ensure that they do not lend their DSC’s to others which may lead to misuse.
- 7) Bidder then logs in to the site through the secured log-in by entering their user ID / password and the password of the DSC / e-Token.

SEARCHING FOR TENDER DOCUMENTS

- 1) There are various search options built in the CPP Portal, to facilitate bidders to search active tenders by several parameters. These parameters could include Tender ID, organization name, location, date, value, etc. There is also an option of advanced search for tenders, wherein the bidders may combine a number of search parameters such as organization name, form of contract, location, date, other keywords etc. to search for a tender published on the CPP Portal.
- 2) Once the bidders have selected the tenders they are interested in, the same can be moved to the respective ‘My Tenders’ folder. This would enable the CPP Portal to intimate the bidders through SMS / e-mail in case there is any corrigendum issued to the tender document.

- 3) The bidder should make a note of the unique Tender ID assigned to each tender, in case they want to obtain any clarification / help from the Helpdesk.

PREPARATION OF BIDS

- 1) Bidder should take into account any corrigendum published on the tender document before submitting their bids.
- 2) Please go through the tender advertisement and the tender document carefully to understand the documents required to be submitted as part of the bid. Please note the number of covers in which the bid documents have to be submitted, the number of documents - including the names and content of each of the document that need to be submitted. Any deviations from these may lead to rejection of the bid.
- 3) To avoid Network congestion, Bidder is recommended to upload file size of up to Maximum 35 MB per part. However, in case file size exceeds 35 MB, bidder may compress the files by scanning with 75 dpi setting as per s.no 4 below and can use additional 25 MB space ("My Documents") provided to the bidder as per s.no 5 below.
- 4) Bidder, in advance, should get ready the bid documents to be submitted as indicated in the tender document and generally, they can be in PDF / XLS / RAR / DWF formats. **Bid documents may be scanned with 75 dpi with black and white option. However, Price Schedule / SOR shall be strictly in RAR format without altering any contents of the formats uploaded by EIL in their Bidding Document.**
- 5) To avoid the time and effort required in uploading the same set of standard documents which are required to be submitted as a part of every bid, a provision of uploading such standard documents (e.g. PAN card copy, annual reports, auditor certificates etc.) has been provided to the bidders. Bidders can use "My Documents" area available to them to upload such documents. These documents may be directly submitted from the "My Documents" area while submitting a bid, and need not be uploaded again and again. This will lead to a reduction in the time required for bid submission process.

SUBMISSION OF BIDS

- 1) Bidder should log into the site well in advance for bid submission so that he/she upload the bid in time i.e. on or before the bid submission time. Bidder will be responsible for any delay due to other issues.
- 2) The bidder has to digitally sign and upload the required bid documents one by one as indicated in the tender document.
- 3) Bidder has to select the payment option as "offline" to pay the tender fee / EMD as applicable and enter details of the instrument.
- 4) Bidder should prepare the EMD as per the instructions specified in the tender document. The original should be posted/couriered/given in person to the Tender Processing Section, as per instructions specified in ITB. The details of the DD/any other accepted instrument, physically sent, should tally with the details available in the scanned copy and the data entered during bid submission time. Otherwise the uploaded bid will be rejected.
- 5) A Price Bid format has been provided with the tender document to be filled by all the bidders. Bidders are requested to note that they should necessarily submit their financial bids in the format provided and no other format is acceptable. Bidders are required to download the Price Bid file, open it and complete the cells with their respective financial quotes and other

details (such as name of the bidder). No other cells should be changed. Once the details have been completed, the bidder should save it and submit it online, without changing the filename. If the Price Bid file is found to be modified by the bidder, the bid will be rejected.

- 6) The server time (which is displayed on the bidders' dashboard) will be considered as the standard time for referencing the deadlines for submission of the bids by the bidders, opening of bids etc. The bidders should follow this time during bid submission.
- 7) All the documents being submitted by the bidders would be encrypted using PKI encryption techniques to ensure the secrecy of the data. The data entered cannot be viewed by unauthorized persons until the time of bid opening. The confidentiality of the bids is maintained using the secured Socket Layer 128 bit encryption technology. Data storage encryption of sensitive fields is done.
- 8) The uploaded tender documents become readable only after the tender opening by the authorized bid openers.
- 9) Upon the successful and timely submission of bids, the portal will give a successful bid submission message & a bid summary will be displayed with the bid no. and the date & time of submission of the bid with all other relevant details.
- 10) The bid summary has to be printed and kept as an acknowledgement of the submission of the bid. This acknowledgement may be used as an entry pass for any bid opening meetings.

RETENDER

Please note that if Tender has been retendered, than it is mandatory for the bidder to submit their offer again on CPP Portal.

WITHDRAWAL OF BID

It may please be noted that bidders now have an additional feature of withdrawing their bids before due date and time. After submitting the bid on the CPP Portal, if the bidder wishes to withdraw his bid, he can do so. However, if the bidder withdraws his bid, he will be exempted from further participation in the tender and won't be able to submit his bid again for that particular tender.

ASSISTANCE TO BIDDERS

- 1) Any queries relating to the tender document and the terms and conditions contained therein should be addressed to the Tender Inviting Authority for a tender or the relevant contact person indicated in the tender.
- 2) Any queries relating to the process of online bid submission or queries relating to CPP Portal in general may be directed to the 24 x 7 CPP Portal Helpdesk. The contact number for the helpdesk is 1800-3070-2232 and Mobile Nos +91-7878007972, +91-7878007973.

Restriction on Procurement from Bidders from Country(ies) sharing land border with India

- 1.0 Department of Expenditure (DoE) vide **O.M. No. 7/10/2021-PPD(1) dated 23.02.2023** has issued the revised guidelines for Restrictions on Procurement from Bidders from Country(ies) sharing Border with India. These guidelines are available on the website of DoE (<https://doe.gov.in>).
- 2.0 **Requirement of registration from Competent Authority:**
 - i). Any Bidder from a country which shares a land border with India will be eligible to bid in any procurement whether of goods, services (including consultancy services and non-consultancy services) or works (including turnkey projects) only if the Bidder is registered with the Competent Authority, specified in **Annexure-I of DoE O.M. No. 7/10/2021-PPD(1) dated 23.02.2023..**
 - ii). Any Bidder (including an Indian bidder) who has a Specified Transfer of Technology (ToT) arrangement with an entity from a country which shares a land border with India will be eligible to bid in any procurement whether of goods, services (including consultancy services and non-consultancy services) or works (including turnkey projects) only if the Bidder is registered with the Competent Authority, specified in **Annexure-I of DoE O.M. No. 7/10/2021-PPD(1) dated 23.02.2023.**
- 3.0 **This Order shall not apply to the following special cases:**
 - i). In projects which receive international funding with the approval of the Department of Economic Affairs (DEA), Ministry of Finance, the procurement guidelines applicable to the project shall normally be followed, notwithstanding anything contained in this order and without reference to the Competent Authority. Exceptions to this shall be decided in consultation with DEA.
 - ii). This order shall not apply to procurement by Indian missions and by offices of Government agencies/ undertakings located outside India.
 - iii). This order will not apply to Bidders (or Entities) from those countries (even if sharing a land border with India) to which the Government of India has extended lines of credit or in which the Government of India is engaged in development projects. Updated lists of countries to which lines of credit have been extended or in which development projects are undertaken are given on the website of the Ministry of External Affairs.
 - iv). Procurement of spare parts and other essential service support like Annual Maintenance Contract (AMC)/ Comprehensive Maintenance Contract (CMC), including consumables for closed systems, from Original Equipment Manufacturers (OEMs) or their authorized agents, shall be exempted from the requirement of registration.
- 4.0 **Definitions:**
 - i). **"Bidder"** (including the term 'Tenderer', 'Consultant' 'Vendor' or 'Service Provider' in certain contexts) means any person or firm or company,

including any member of a Consortium or Joint Venture (that is an association of several Persons, or Firms or Companies), every artificial juridical person not falling in any of the descriptions of Bidders stated hereinbefore, including any Agency, Branch or Office controlled by such person, participating in a procurement process.

- ii). **"Tender"** will include other forms of procurement, except where the context requires otherwise.
- iii). **"Transfer of Technology"** means dissemination and transfer of all forms of commercially usable knowledge such as transfer of know-how, skills, technical expertise, designs, processes and procedures, trade secrets, which enables the acquirer of such technology to perform activities using the transferred technology independently. (Matters of interpretation of this term shall be referred to the Registration Committee constituted by the Department for Promotion of Industry and Internal Trade, and the interpretation of the Committee shall be final.)
- iv). **"Specified Transfer of Technology"** means a transfer of technology in the sectors and/ or technologies, specified in [paragraph 5.0](#), occurring on or after 23.07.2020.
- v). **"Bidder (or entity) from a country which shares a land border with India"** means
 - (a) An entity incorporated, established or registered in such a country; or
 - (b) A subsidiary of an entity incorporated, established or registered in such a country; or
 - (c) An entity substantially controlled through entities incorporated, established or registered in such a country; or
 - (d) An entity whose beneficial owner is situated in such a country; or
 - (e) An Indian (or other) agent of such an entity; or
 - (f) A natural person who is a citizen of such a country; or
 - (g) A Consortium or Joint Venture where any member of the Consortium or Joint Venture falls under any of the above.
- vi). **Beneficial Owner** for the purposes of [paragraph 4.0 v\) \(d\)](#) will be as under:
 - a) **In case of a Company or Limited Liability Partnership**, the beneficial Owner is the natural person(s), who, whether acting alone or together, or through one or more juridical person(s), has a controlling ownership interest or who exercises control through other means.

Explanation: -

1. "Controlling ownership interest" means ownership of, or entitlement to, more than twenty-five per cent of shares or capital or profits of the company;
2. "Control" shall include the right to appoint the majority of the Directors or to control the management or policy decisions,

including by virtue of their shareholding or management rights or shareholders agreements or voting agreements;

- b) **In case of a Partnership Firm**, the beneficial Owner is the natural person(s) who, whether acting alone or together, or through one or more juridical person, has ownership of entitlement to more than fifteen percent of capital or profits of the partnership;
- c) **In case of an Unincorporated Association or body of Individuals**, the beneficial Owner is the natural person(s), who, whether acting alone or together, or through one or more juridical person, has ownership of or entitlement to more than fifteen percent of the property or capital or profits of such association or body of individuals;
- d) Where no natural person is identified under a) or b) or c) above, the beneficial Owner is the relevant natural person who holds the position of senior managing official;
- e) **In case of a Trust**, the identification of beneficial Owner(s) shall include identification of the author of the trust, the trustee, the beneficiaries with fifteen percent or more interest in the trust and any other natural person exercising ultimate effective control over the trust through a chain of control or ownership.

vii). **"Agent"** is a person employed to do any act for another, or to represent another in dealings with third persons.

[Note:

- i). A person who procures and supplies finished goods from an entity from a country which shares a land border with India will, regardless of the nature of his legal or commercial relationship with the producer of the goods, be deemed to be an Agent for the purpose of this Order.
- ii). However, a Bidder who only procures raw material, components etc. from an entity from a country which shares a land border with India and then manufactures or converts them into other goods will not be treated as an Agent.]

5.0 **Sensitive Sectors/ Technologies (relevant only for the provisions on ToT arrangements):**

- i). Certain sectors and technologies have been identified as sensitive from the national security point of view. **The sectors listed in [Schedule I \(copy attached\)](#) are considered Category-I sensitive sectors. The sectors listed in [Schedule II \(copy attached\)](#) are considered Category-II sensitive sectors.** The technologies listed in [Schedule III \(copy attached\)](#) are considered sensitive technologies.
- ii). For **Category-I sensitive sectors**, Bidders with ToT arrangement in any technology with an entity from a country which shares a land border with India shall require registration.
- iii). For **Category-II sensitive sectors**, Bidders with ToT arrangement in the sensitive technologies listed in [Schedule III](#), with an entity from a country which shares a land border with India shall require registration.

- iv). In **Category-II sensitive sectors**, the Secretary (or an officer not below the rank of Joint Secretary to Government of India, so authorized by the Secretary) of the Ministry/ Department of the Government of India is empowered, after due consideration, to waive the requirement of registration for a particular item/ application or a class of items/ applications from the requirement of registration, even if included in Schedule-III. The Ministry/ Department concerned shall intimate the Department for Promotion of Industry and Internal Trade (DPIIT) and National Security Council Secretariat (NSCS) of their decision to waive the requirement of registration.

Ministries/ Departments of the Government of India are not required to consult the DPIIT/ NSCS before deciding and are only required to intimate the decision to DPIIT/ NSCS. If any point is raised by DPIIT/ NSCS, it should be considered in future procurements; ongoing procurement for which the waiver was granted need not be interrupted or altered.

Based on security considerations, a Ministry/ Department in a **Category-II sensitive sector** or other Ministries/ Departments may recommend to DPIIT inclusion of any other technology in the list of sensitive technologies, either generally or for their Ministry/ Department.

6.0 **Sub-contracting in works contracts**

In works contracts, including turnkey contracts, Contractors shall not be allowed to sub-contract works to any Contractor from a country which shares a land border with India unless such contractor is registered with the Competent Authority. The definition of "**Contractor from a country which shares a land border with India**" shall be as given in above [paragraph 4.0 v\)](#).

[Note: Procurement of raw material, components, etc. does not constitute sub- contracting.]

7.0 **Certificate regarding compliance**

Bidder shall submit a certificate of Compliance in the enclosed [Form-I A/ Form-I B/ Form - II](#) (as applicable).

This certificate shall be on the Bidder's Letter head and shall be duly signed & stamped by the authorised signatory of the Bidder.

In case at any stage, if it found the certification given by the Bidder is false, their Bid shall be rejected and shall be liable for other penal actions like placement on Suspension/ banning or forfeiture of EMD (if applicable). However, if this is found after order placement, this would be ground for immediate termination and further legal actions in accordance with law/ provisions of Bidding Document including suspension/ banning and forfeiture of CPBG/ Security Deposit.

BIDDER'S UNDERTAKING
(On Company's Letter Head)

To,

M/s Engineers India Limited/ _____ (Name of the client)

Tender Name : _____

Tender No. : _____

"I have read the clause regarding restrictions on procurement from a Bidder of a country which shares a land border with India; I hereby certify that, Bidder M/s _____ (Name of the Bidder) is:

i).	Not from such a country	[]
ii).	If from such a country, has been registered with the Competent Authority	[]

Notes:

- a) Bidder to tick appropriate option (√) in either i) or ii) above)
- b) In case of sl. no. ii) above, Bidder to attach evidence of valid registration by the Competent Authority.

I hereby certify that the Bidder fulfills all requirements in this regard and eligible to be considered.

Place :

Signature (#):

Date :

Name :

Designation :

Seal :

(#) Undertaking shall be signed by the authorized signatory of the Bidder.

BIDDER'S UNDERTAKING IN CASE OF SUB-CONTRACTING IN WORK CONTRACTS

(On Company's Letter Head)

To,

M/s Engineers India Limited/ _____ (Name of the client)

Tender Name : _____

Tender No. : _____

"I have read the clause regarding restrictions on procurement from a Bidder of a country which shares a land border with India and on sub-Contracting to Contractors from such countries; I hereby certify that, Bidder M/s _____ (Name of the Bidder) is:

i).	Not from such a country	[]
ii).	If from such a country, has been registered with the Competent Authority and will not sub-Contract work to a Contractor from such countries unless such Contractor is registered with the Competent authority	[]
Notes: a) Bidder to tick appropriate option (√) in either i) or ii) above) b) In case of sl. no. ii) above, Bidder to attach evidence of valid registration by the Competent Authority.		

I hereby certify that the Bidder fulfills all requirements in this regard and eligible to be considered.

Place :

Date :

Signature (#):

Name :

Designation :

Seal :

(#) Undertaking shall be signed by the authorized signatory of the Bidder.

BIDDER'S UNDERTAKING IN CASE OF TRANSFER OF TECHNOLOGY (ToT) ARRANGEMENT

(On Company's Letter Head)

To,

M/s Engineers India Limited/ _____ (Name of the client)

Tender Name : _____

Tender No. : _____

"I have read the clause regarding restrictions on procurement from a Bidder having Transfer of Technology (ToT) arrangement. Bidder M/s _____ (Name of the Bidder), hereby certify that,

i).	Bidder does not have any ToT arrangement requiring registration with the competent authority	[]
ii).	Bidder has valid registration to participate in this procurement	[]

Notes:

- a) Bidder to tick appropriate option (√) in either i) or ii) above)
- b) In case of sl. no. ii) above, Bidder to attach evidence of valid registration by the Competent Authority.

I hereby certify that the Bidder fulfills all requirements in this regard and eligible to be considered.

Place :

Signature (#):

Date :

Name :

Designation :

Seal :

(#) Undertaking shall be signed by the authorized signatory of the Bidder

Integrity Pact

Between

Petronet LNG Limited hereinafter referred to as "The Principal",

And

.....
hereinafter referred to as "Counterparty"

Preamble

The Principal intends to award, under laid down organizational procedures, Contract/s for

The Principal values full compliance with all relevant laws and regulations, and of fairness and transparency in its relations with its all counterparties.

In order to achieve these goals, The Principal has appointed an external independent monitor (*Refer Bid Data Sheet (BDS) for details of independent monitor*) who will monitor the tender process and the execution of the contract for compliance with the principles mentioned above.

Section I - Commitments of the Principal

1. The Principal commits itself to take all measures necessary to observe the following principles:-
 - a) The Principal is committed to have most ethical business dealings with Counterparties.
 - b) The Principal values its relationship with all Counterparties and will deal with them in a transparent manner with equity and fairness.
 - c) The Principal and/or its Associates (Officers, Directors, Agents, Consultants, Advisors, etc.) will not seek or take any undue benefit directly or indirectly for themselves or for third parties.
 - d) The Principal will exclude all of Associates who may be prejudiced or have a Conflict of interest in dealings with Counterparties.
 - e) The Principal will honour its commitments and make due payments to Counterparties on timely basis.
 - f) The Principal will initiate action and pursue it vigorously whenever corruption or unethical behaviour occurs.
2. No Associate of the Principal, personally or through family members, will in connection with the tender for , or the execution of a contract, demand, take a promise for or accept, for



him/herself or third person, any material or immaterial benefit which he/she is not legally entitled to.

3. The Principal will, during the tender process treat all Counterparties with equity and fairness. The Principal will in particular, before and during the tender process, provide to all Counterparties the same information and will not provide to any Counterparty confidential/additional information through which the Counterparty could obtain an advantage in relation to the tender process or the contract execution.
4. If the Principal obtains information on the conduct of any of its Associates, which is a breach of the above or a criminal offence under the relevant Anti-Corruption Laws of India, or if there be a substantive suspicion in this regard, the Principal will inform the Independent Monitor and in addition can initiate disciplinary actions.

Section II - Commitments of the Counterparties

The Counterparty commits itself to take all measures necessary to prevent corruption. He commits himself to observe the following principles during his participation in the tender process and during the contract execution.

1. The Counterparty will not, directly or through any other person or firm, offer, promise or give to any of the Principal's Associate employees involved in the tender process or the execution of the contract or to any third person any material or immaterial benefit which he/she is not legally entitled to, in order to obtain in exchange any advantage of any kind whatsoever during the tender process or during the execution of the contract.
2. The Counterparty will not enter with other Counterparty into any undisclosed agreement or understanding, whether formal or informal. This applies in particular to prices, specifications, certifications, subsidiary contracts, submission or non-submission of bids or any other actions to restrict competitiveness or to introduce cartelization in the bidding process.
3. The Counterparty will not commit any offence under the relevant Anti-corruption Laws of India the Counterparty will not use improperly, for purposes of competition or personal gain, or pass on to others, any information or document provided by the Principal as part of the business relationship, regarding plans, technical proposals and business details, including information contained or transmitted electronically unless authorized by Petronet.
4. The Counterparty will not instigate third persons to commit offences outlined above or be an accessory to such offences.
5. The Counterparty will not bring any Political, governmental or diplomatic influence to gain undue advantage in its dealings with Petronet.
6. The Counterparty will not make any false or misleading allegation against Petronet or its Associates.

Section III- Disqualification from tender process and exclusion from future contracts

1. If the Counterparty has committed a transgression through a violation of Section II such as



to put his reliability or credibility into question, the Principal is entitled also to exclude the Counterparty from future contract award processes. The imposition and duration of the exclusion will be determined by the severity of the transgression. The severity will be determined by the circumstances of the case, in particular the number of transgressions, the position of the transgressors within the company hierarchy of the Counterparty and the amount of the damage. The exclusion will be imposed for a minimum of 6 months and maximum of 3 years.

2. The Counterparty accepts and undertakes to respect and uphold the Principal's absolute right to resort to and impose such exclusion and further accepts and undertakes not to challenge or question such exclusion on any ground, including the lack of any hearing before the decision to resort to such exclusion is taken. This undertaking is given freely and after obtaining independent legal advice.
3. If the Counterparty can prove that he has restored/recouped the damage caused by him and has installed a suitable corruption prevention system, the Principal may revoke the exclusion prematurely.

Section IV - Compensation for Damages

1. If the Principal has disqualified the Counterparty from the tender process prior to the award according to Section - III the Principal is entitled to demand and recover from the Counterparty liquidated damages equivalent Earnest Money Deposit / Bid Security.
2. If the Principal has terminated the contract according to Section- III, or if the Principal is entitled to terminate the contract according to Section - III (3), the Principal shall be entitled to demand and recover from the counterparty Contractor liquidated damages equivalent to Security Deposit / Performance Bank Guarantee.

Section V - Previous transgression

1. The Counterparty declares that no previous transgressions occurred in the last 3 years with any other Company that could justify his exclusion from the tender process.
2. If the Counterparty makes incorrect statement on this subject, he can be disqualified from the tender process or the contract, if already awarded, can be terminated for such reason.

Section VI – Equal treatment of all Counterparty / Subcontractors

1. The Counterparty undertakes to demand from all subcontractors a commitment in conformity with this Integrity Pact, and to submit it to the Principal before contract signing.
2. The Principal will disqualify from the tender process all bidders who do not sign this Pact or violate its provisions.

Section VII - Criminal charges against violating Counterparty/ Subcontractors

If the Principal obtains knowledge of conduct of a Counterparty or Subcontractor, or of an employee or a representative or an associate of a Counterparty or Subcontractor which



constitutes corruption, or if the Principal has substantive suspicion in this regard, the Principal will inform the Independent Monitor who may initiate criminal proceedings against the violator.

Section VIII -Independent Monitor

1. The Principal will appoint competent and credible Independent Monitor for this Pact, who shall be one of the Independent Director on the Board of the Principal. The task of the Independent Monitor is to review independently and objectively, whether and to what extent the parties comply with the obligations under this agreement.
2. The Independent Monitor is not subject to instructions by the representatives of the parties and performs his functions neutrally and independently. He reports to the Chairperson of the Board of the Principal.
3. The Counterparty will accept that the Independent Monitor has the right to access without restriction to all Project documentation of the Principal including that provided by the Counterparty. The Counterparty will also grant the Monitor, upon his request and demonstration of a valid interest, access to his project documentation.
4. The Principal will provide to the Independent Monitor sufficient information when requested about all meetings among the parties related to the Project provided such meetings could have an impact on the contractual relations between the Principal and the Contractor. The parties offer to the Monitor the option to participate in such meetings.
5. As soon as the Independent Monitor notices, or believes to notice, a violation of this agreement, he will so inform the Management of the Principal and request the Management to discontinue or heal the violation, or to take other relevant action.
6. The word 'Independent Monitor' would include both singular and plural.

Section IX - Pact Duration

This Pact begins when both parties have legally signed it. It expires for the Contractor 12 months after the last payment under the respective contract, and for all other Counterparties 6 months after the contract has been awarded.

If any claim is made / lodged during this time, the same shall be binding and continue to be valid despite the lapse of this pact as specified above, unless it is discharged / determined by Chairperson of the Principal.

Section X - Other Provisions

1. This agreement is subject to Indian Law. Place of performance and jurisdiction is the Registered Office of the Petronet LNG Ltd, World Trade Centre, First Floor, Babar Road, Barakhamba Lane, New Delhi.
2. Changes and supplements as well as termination notices need to be made in writing. Side agreements have not been made.

3. If the Counterparty is a partnership or a consortium; this agreement must be signed by all partners or consortium members.
4. Should one or several provisions of this agreement turn out to be invalid, the remainder of this agreement remains valid. In this case, the parties will strive to come to an agreement to their original intentions.



For the Principal

For the Counterparty

Place Witness 1:

Date Witness 2:

- 1.0 Bidders are informed that Reverse Auction will be conducted for finalizing this Tender. Accordingly, the bidders must quote most competitive prices in the first instance itself. The schedule of online Reverse Auction will be conveyed to short listed bidders (as per Clause No. 2 below) after opening of price bid.
- 2.0 a) In case there are more than three (3) techno-commercially acceptable bids, bidder having highest quote (H1 bidder) will not be allowed to **participate in the Reverse Auction process and his bid will be rejected.**
- b) In case of more than one H1 bidders (i.e. H1 tie), latest bid received (bidder whose bid is received at the last) out of all H1 bidders will be rejected as per provisions mentioned above. In case of multi-lot auction, itemwise H1 bidder will be disqualified as per the provision mentioned above.
- 3.0 Once the schedule of online Reverse Auction is conveyed to the bidders, it will be mandatory for the bidders to participate in online Reverse Auction, failing which, the bidder shall be liable for punitive action including but not limited to rejection of offer, encashment of bid security, wherever applicable, etc. For this purpose, even log-in to the system shall be construed as participation.

Further, if the L1 bidder (based on the lowest evaluated prices out of all the techno-commercial acceptable bidder) does not log-in during online Reverse Auction and Reverse Auction does not lead to any bid lower than the above L1 bid, then the case shall be refloated for that item/ group and the L1 bidder shall be liable for punitive action including but not limited to encashment of bid security, wherever applicable, or any other action as defined in RFQ/Bidding document.

4.0 Training to bidder

Before the online Reverse Auction, EIL shall demonstrate/train bidder's nominated person(s) on the steps involved and explain the methodology of the reverse auction. The training and registration shall be without any cost to the bidder.

On completion of the training, bidders are required to confirm that they have received the complete training before start of online RA process and furnish the process compliance form to EIL. It is the responsibility of the bidder to get acquainted with the online reverse auction methodology so as to avoid any confusion or misunderstanding during the auction.

Submission of the RA compliance form before price opening is a mandatory requirement and not submitting the same shall be considered equivalent to withdrawal of offer. In such an event, the prices of this bidder shall not be opened and online reverse auction shall be conducted without this bidder. Such a bidder shall be liable for punitive action including but not limited to rejection of offer, encashment of bid security, in line with prevailing EIL/PLL policy on such matters.

For participation in the online Reverse Auction, the authorized signatory of the bid shall have a valid class III digital signature certificate in his name issued from an agency certified with certifying authority of India.

Reverse Auction shall be conducted on <https://eauction.gov.in/eauction/#/>.

5.0 Schedule for Reverse Auction

The online Reverse Auction shall be scheduled for a duration of 30 minutes. If a bidder places a Bid in the last 3 minutes of scheduled closing time of the Auction, the Auction time shall get extended automatically for another 5 minutes from the time of the last Bid placed. Accordingly, as the bidders keep on bidding the prices in the RA, RA will keep on extending for 5 minutes from the bid. However, when there is no Bid in the last 3 minutes, the Auction shall be closed automatically without any extension.

6.0 Grouped items/parts

The term "item" in this document shall also mean "group of items", wherever formed for basket level bidding, evaluation and ordering.

7.0 Bid Price

The price shall be based on the scope, technical specifications and commercial terms & conditions and other part of Bidding document agreed up to the date of reverse auction.

8.0 Bid Decrement

Bid decrement shall be 0.1% of the Opening Price. The bidder has to lower his bid in multiples of the bid decrement. The Bidder cannot increase its price in Reverse Auction.

9.0 Bidding Currency

Bidding will be conducted in Indian Rupees (INR) for Indian Bidders and equivalent Indian Rupees for foreign bidders. The equivalent Indian Rupees for foreign bidders shall be worked out by foreign bidders using the multiplication factor as given in the Evaluation Criteria.

10.0 Evaluation Criteria

The process of evaluation may result in different multiplication factors for different bidders, due to the loading criteria for techno-commercial deviations (if applicable as per bidding document) and foreign exchange rates etc. These factors will be forwarded to the bidders, at least, 24 hours before the start of auction.

The prices that shall be bid during the auction shall be summation of the evaluated prices (i.e., basic prices multiplied by loading factor) for the respective item/group/part and the same shall be used for ranking of the bidders. The bidder shall work out his basic prices accordingly.

11.0 Auction process

- Each Bidder shall be assigned a Unique User Name & Password. The Bidders are requested to change the Password and edit the information in the Registration Page after the receipt of initial Password. All bids using the Login ID given to the bidder(s) will be deemed to have been submitted by the bidders. During the auction, bidders will be referred by proxy names say B₁, B₂, B₃ etc. and identity will not be disclosed. Accordingly, during the auction, the bidders will be visible with these proxy names to all monitoring the auction.

- The Reverse Auction shall be conducted based on the lowest item wise evaluated price out of all the bidders as the Opening Price. The Bidder shall be able to bid lower than the opening price in multiples of the decrement.
- Only one bidder shall be at a particular position/rank, which means only one L1.

However, In case of tie during the reverse auction i.e. two Bidders entering the same lowest price, the Bidder who enters the price first in the system will be considered as L-1 and the other bidder will be L-2.

- The Bidder shall be able to view the following on his screen along with the necessary fields:
 - i. Opening Price.
 - ii. Leading Bid in the Auction, i.e., the lowest bid.
 - iii. Bid placed by him.
 - iv. Minimum Decrement

- The Opening Price and the Bid Decrement shall be displayed on the auction site at the start of the auction. However, the bidders shall be able to view the auction details, generally, 15 to 30 minutes before the start of actual auction.

At no point of time will any bidder see the names of other bidders, or the prices of bidders other than the lowest bid.

- A bidder can continue to revise his bid till the auction ends. However, the Bidder cannot quote / Bid equal to the Leading / Lowest Bid. He must always quote lower than the Leading / Lowest Bid.
- The evaluation criteria is based on Price alone. The Bidder who quotes the lowest evaluated Price is determined as the lowest bidder.
- However, if Reverse Auction does not lead to any bid, EIL/PLL shall reserve the right to award the job based on the lowest prices quoted in priced bid.
- Apart from the participating bidders, the Reverse Auction shall be visible, while in progress to authorized officials of Purchaser, who are monitoring the process. During the auction, bidders will appear by their proxy names to anybody accessing the portal.

12.0 Bid Validity

The Bid Price submitted in the reverse auction shall be firm and valid for acceptance for a period of 30 days from the date of reverse auction and shall not be subject to any change whatsoever.

13.0 Bids once placed, binding on the Bidder

The bid of the bidder will be taken to be an offer to sell. Bids once submitted by the bidder cannot be cancelled. The bidder is bound to sell the material/ services at the price that they bid. If any bidder backs out and does not accept the order as per the rates quoted in Reverse Auction, the bidder shall be liable for penal action in line with the prevailing EIL/PLL policy, including encashment of bid security, as applicable and

the case shall be refloated.

14.0 Lowest bid of a Bidder

During the process of reverse auction, the bidder may submit several bids. In case the bidder submits such multiple bids, the lowest bid will be considered as the bidder's final offer to sell.

15.0 Submission of final prices by successful bidder

Based on the lowest evaluated price bid in the reverse auction, the successful bidder shall confirm the final evaluated price as per reverse auction, in the format (Annexure-A enclosed herewith) within two days of the completion of Auction to EIL, duly signed and stamped as token of acceptance without any new condition.

Net reduction offered by the bidder during the auction from his quoted prices will be distributed proportionally among, as applicable:

- All the heads considered for evaluation of particular item/group in case of MR
- On all items of item rate tender and amount on which taxes & duties considered
- Break-up of lumpsum prices in case of packaged/lumpsum tender.

EIL/PLL shall place the order after back calculating the final price based on the multiplication factor informed to the bidder as per clause 10 above. Accordingly, bidders need not to submit cost breakup of their final quoted prices in the reverse auction.

16.0 General

- The bidders may quote from their own offices/ place of their choice. Bidder will be responsible for any issues at their end during the entire process of Reverse Auction on E-Tender portal.
- A landline phone of EIL/PLL shall be made available during the reverse auction for any urgent authorised communication with the Bidder. Any unauthorised communication shall not be entertained during reverse auction.
- Any issues faced by the bidders during the auction process must be communicated directly to the nodal office of EIL/PLL.

Purchaser may extend the bidding time, in such a case, appropriately (generally by half an hour) but not more than once per bidder. However, due to malfunctioning or breakdown in internet connectivity at Auction Website's end, EIL/PLL can suspend or pause the reverse auction or may also decide to cancel Reverse Auction and re-conduct it.

Message of extension of auction time or suspend or paused shall be communicated to all the bidders through system broadcast message on the RA portal.

- The Bidder, himself or any of his representatives, shall not involve in Price manipulation of any kind directly or indirectly by communicating with other bidder.
- The Bidder shall not divulge either his Bids or any other exclusive details of Purchaser to any other party.
- Bidders agree to non-disclosure of trade information regarding the purchase, identity of EIL/PLL, bid process, bid technology, bid documentation and bid details.
- EIL/PLL can decide to extend, reschedule or cancel any Auction. No bidder can claim any kind of compensation on account of the same.

- EIL/PLL shall not have any liability to Bidders for any interruption or delay in access to the site irrespective of the cause.
- EIL/PLL shall not be responsible for any direct / indirect / consequential losses / damages, on account of systems problems, inability to use the system, loss of electronic information etc.
- EIL/PLL shall be at liberty to cancel the reverse auction process / tender at any time, before ordering, without assigning any reason.
- EIL/PLL reserves the right to conduct price negotiation with overall L1 Bidder based on the outcome of RA.
- EIL/PLL decision on award of Contract shall be final and binding on all the Bidders.

Annexure-A

(Letter to be sent in Bidder's Letter head, duly signed and stamped by authorised signatory
Holding Power of Attorney for this work)

Ref. No.: _____

Date: _____

To

Engineers India Limited
R&D Complex, Sector-16,
Gurugram (India).

Attn. : _____

Bidding Document No. : _____

Name of Work : _____

Project : _____

Sub: FINAL EVALUATED PRICE QUOTED DURING REVERSE AUCTION

Dear Sir,

We confirm that during the Reverse Auction conducted on _____ for the above mentioned work, we have quoted the final evaluated price as under:

For Item Sl. No.:	Final evaluated price (in Figure)	Final evaluated price (in words)
	Rs. _____/-	Rupees _____ only
	Rs. _____/-	Rupees _____ only

Thanking you,

Signature with Company Seal

Name:

Company / Organisation:

Designation within Company/Organisation:

Address of Company/ Organisation:

Mobile No.:

E mail:

Fax No.:

PROFORMA OF BANK GUARANTEE FOR EMD

(To be submitted on non-judicial stamp paper of appropriate value to be purchased in the name of the issuing Bank)

To,
Petronet LNG Limited
4th Floor, Tower-I, World Trade Center
Nauroji Nagar
New Delhi - 110029

BG No. : _____
Date of Issue : _____
Date of Expiry : _____
(1 Month beyond bid validity)
Date of Claim : _____
Bank Name : _____

Dear Sirs,

1. In consideration of Petronet LNG Limited established under the Company's Act, 1956 having its registered office at 4th Floor, Tower-I, World Trade Center, Nauroji Nagar, New Delhi-110029, India (hereinafter referred to as the "Company" which expression shall unless repugnant to the context or meaning thereof, include all its Successors, Administrators, Executors and permitted Assignees), has floated/issued a Tender/ Bidding Document for

_____ (Name of work)[Bidding Document No.: _____] through press notification/ on limited basis, (hereinafter referred to as the "Tender" which expression shall include all the amendments thereto) and M/s _____ (Name of Bidder) having its Head/Registered Office at _____ (herein after referred to as the "Bidder" which expression unless repugnant to the context or meaning thereof, shall include all its Successors, Administrators, Executors and permitted Assignees) have submitted a Bid in response to the Tender enquiry and the Bidder having agreed to furnish as a condition precedent for participation in the said Tender an unconditional and irrevocable Bank Guarantee *hereinafter shall be referred to as this "Guarantee"+ of value _____ [in fig. as per currency indicated in Notice/Letter Inviting Bid] [in words _____]

_____] for the due performance of the Bidder's obligations as contained in the Instructions to Bidder *ITB+ and other terms and conditions contained in the Tender document supplied by the Company which amount is liable to be forfeited on the happening of any of the contingencies mentioned in the said Tender document.

2. We _____ (Name of Bank) established /registered under the laws of _____ (Name of the Country and Act/Laws) having its registered office at _____ (hereinafter referred to as the "Bank" which expression shall unless repugnant to the context or meaning thereof include all its successors, administrators, executors and permitted assignees) do hereby guarantee on behalf of the Bidder and undertake to pay immediately on demand signed by the Company's duly authorized officer, to the Company any money or all money up to the extent of the value of this Guarantee at the time but in any case not exceeding (in Fig. with Currency) _____ (in words with Currency) in aggregate at any time without any demur, reservation, recourse, contest and/or without any reference to the Bidder. Any such demand made by the Company on the Bank shall be conclusive and binding on the Bank irrespective of any dispute or difference raised by the Bidder or any dispute pending before any Court, Tribunal, Arbitrator or any other authority.

3. The Bank confirms that this Guarantee has been issued in accordance with the appropriate laws in India [the country of issue].
4. The Bank also agrees that this Guarantee herein contained shall be irrevocable and shall continue to be enforceable in accordance with the Indian Laws and subject to exclusive jurisdiction of Indian Courts as per condition stipulated in Tender Document.
5. The Bank also agrees that the Company at its option shall be entitled to enforce this Guarantee against the Bank as a principal debtor, in the first instance, without proceeding against the Bidder and without any reference to the Bidder and notwithstanding any security or other Guarantee that the Company may have in relation to the Bidder's liabilities.
6. The Bank further agrees that this Guarantee herein contained shall remain in full force up to and including one month after the expiry of the Period of Bid validity i.e. upto _____ [01 Month beyond the bid validity] that is taken as the obligations of the Bidder as per Tender document and it shall continue to be enforceable until all the dues of the Company, if any, under or by virtue of this Guarantee have been fully paid and its claim satisfied or discharged.
7. The Bank further agrees that this Guarantee shall not be determined or affected by the liquidation or winding up, dissolution or change of constitution or insolvency of the Bidder during the period this Guarantee is in force but shall be in all respects and for all purposes be binding and operative until payment of all money due to the Company in respect of such liability or liabilities is paid or no claim is lodged by the Company to the Bank within the claim period after the Guarantee expires.
8. The Bank further agrees that this Guarantee shall not be affected by any change in the Bank's Constitution. The Bank also undertakes not to revoke this Guarantee during its currency.
9. The Bank further agrees that to fulfill the Bidder's liability during the bidding process, if requested by the Bidder in writing, the Bank shall issue Amendment to this Guarantee, as and when required, incorporating the extended date of validity and/or other amendment.
10. Notwithstanding anything contained herein above:
 - a) The Bank's liability under this Guarantee is limited to - _____ (in Fig with currency) _____ (in words with currency) in aggregate;
 - b) This Guarantee shall remain in full force up to and including 30 (thirty) days after the expiry of the Period of Bid validity i.e. up to [Date] and any extension(s) thereof on written instruction from the Bidder on whose behalf this Guarantee has been given, in which case it shall remain in full force up to and including 30 (thirty) days after the extended date; and
 - c) The Bank shall be released and discharged from all its liabilities and obligations under this Guarantee unless a written claim or demand is issued to the Bank on or before ____ <Date> or within the 30 (thirty) days of the date of expiry of the extended date and the Company's right under this Guarantee will cease.
11. The Bank further agrees that all claims under this Guarantee is payable to the Company as per the bank details mentioned below:

Beneficiary Name	Petronet LNG Limited
Beneficiary Address	First Floor, World Trade Centre, Babar Road, Barakhamba Lane, New Delhi – 110001
Over Draft Account No.	32519890815
Bank Name	State Bank of India
Branch Address	Corporate Accounts Group Branch-II 4 th & 5 th Floor, Red Fort Capital Parsvanath Towers, Bhal Vir Singh Marg, Gole Market, Near Speed Post Office.

	New Delhi – 110 001
Branch Code	17313
IFSC Code	SBIN0017313

12. The Bank has the power to issue this Guarantee under its Memorandum and Articles of Association and the undersigned is authorized to sign this Guarantee on behalf of the Bank and to bind the Bank thereby.

IN WITNESS whereof, the Bank _____ has executed this Guarantee at _____ (Place) on _____ (Date)

Signed and Sealed by Constituted Attorney

(Signature of a person authorized to sign on behalf of the Bank)

Name:
Designation: Bank
Name:

In presence of witness:

1. Signature _____

Name & Designation:

2. Signature _____

Name & Designation:

[Note: The Bank shall issue the confirmation letter of providing this Guarantee on behalf of the Contractor directly to the beneficiary at the above-mentioned address]

Request Letter: Transmission of Bank Guarantee Cover Message <to be submitted by Bidder to BG issuing bank>

Date: _____

The Manager,
(Bank),
(Branch)

Sub: Inclusion of unique identifier while transmitting BG cover messages.

Dear Sir/Ma'am,

I/We, _____, request you to include unique identifier PLNG574440489 in field 7037 of the SFMS cover messages IFN COV 760 (for BG issuance) and IFN COV 767 (for BG amendment) while transmitting the same to the beneficiary bank (ICICI Bank, IFSC: ICIC00000007). This is required by Petronet LNG Limited as per their tender/contract requirement.

Thanking You,

The Template for MT 760-COV (SFMS) for issuing bank is mentioned below:

```
{
:7020:
:7022:
:7024:EMD/ BID SECURITY
:7025:INRxxxxx
:7026:
:7027:<Date of Issue>
:7029:<Expiry date>
:7030:<Place of Claim Lodgement>
:7031:<Issuing Bank IFSC>
:7032:<Issuing Bank Name>
:7033:<Bidder Name>
:7034:PETRONET LNG LIMITED <Address>
:7035:ICIC00000007
:7036:ICICI BANK LIMITED
:7037:PLNG574440489
-}
```

ANNEXURE-VI TO ITB

Instructions for payment of EMD/Tender Fee through PLL Online EMD Tender Fee Collection portal

- a. Please click or copy the link to the browser.
- b. Please note that bidder has to make EMD and Tender Fee payments separately.
- c. Please fill all the information for EMD or Tender fee, as the case may be, in the online form.
- d. Once bidder submit the information then system will redirect to ICICI bank pay2corp web page where bidder can choose following mode for online payment:
 - i. Debit Card
 - ii. Net banking (Retail/Corporate)
 - iii. Challan mode (EMD only)
- e. Outcome of payment mode selected:
 - i. **Debit card:** once payment is done, bidder will be redirected to PLL webpage and bidder shall get an e-mail confirmation for payment.
 - ii. **Net banking (Retail):** After authorization of payment on the respective bank webpage, bidder will be redirected to PLL webpage and bidder shall get an e-mail confirmation for payment.
 - iii. **Net banking (Corporate):** Bidder has to create the Cheque/ RTGS/ NEFT instruction on the respective bank's webpage, and after that bidder shall be redirected to PLL webpage with Payment awaiting message. Thereafter, transaction needs to be authorised by the approvers on the Corporate Net-banking portal of the respective bank and after authorisation, bidder shall get an e-mail confirmation for payment within next 30 Minutes.
 - iv. **Challan mode:** Bidder has to generate the Challan on pay2corp page, and then he will be redirected to PLL webpage with Payment awaiting message. Thereafter, bidder needs to make the payment to the bank account details provided in challan. Bidder to ensure payment authorization within 7 days from the date of challan generation. Once the payment is done, bidder shall get an e-mail confirmation for payment within next 30 Minutes.
- f. Bidder/s are advised not to close the browser while making online payment through ICICI Pay2corp.
- g. Bidder/s should wait for at least 30 minutes for payment confirmation mail after payment authorization in the respective bank.
- h. In case, amount is deducted from bidder's bank account and email confirmation has not been received by the bidder, then bidder should attach the proof of payment along with bid.
- i. Bidder should ensure the payment amount for EMD/Tender Fee as per Bid Document. In case, bidder has done the payment of incorrect amount then bidder should contact the PLL support team on emd@petronetlng.in.

Steps involved (Bidders perspective)

1. Bidder has to open the given link and following web page will be opened in browser.

The screenshot shows a web browser window with the following details:

- Browser tab: Petronet LNG Limited : EMD/Ten...
- Address bar: petronetlng.in/emd/tender?number=1
- Page Header: Petronet LNG Limited logo, navigation links (PL Corporate, Our Businesses, Our Commitment, Investors), and social media icons.
- Form Title: EMD / Tender Form - Tender No.1
- Form Fields:
 - Type of Payment* (Dropdown menu)
 - Vendor Name (As per bank account)* (Text input)
 - PAN of Vendor* (Text input)
 - Bank Account Number* (Text input)
 - Verify Bank Account Number* (Text input)
 - Amount in INR* (Text input)
 - IFSC* (Text input)
 - Bank Name* (Text input)
 - Branch* (Text input)
 - Name (contact person name)* (Text input)
 - Mobile Number* (Text input)
 - Attachment - Cancelled copy of cheque/Bank letter* (File upload button: Choose File | No file chosen)
 - Email Address (contact person mail id)* (Text input)
- Confirmation: I hereby confirm that the above particulars are accurate.
- Note: For any issues, please reach out to the admin at emd@petronetlng.in
- Disclaimer: If the challan option is selected on the bank payment screen, please ensure that the RTGS/NEFT payment includes the challan number. Please refer the concerned tender document for details including the refund policy.
- Image: A small image with the word "asher" written on it.
- Text Verification: A text input field.

Page Footer: Petronet LNG Limited, Quick links, Other Links

2. Bidder has to fill the following details in respective fields: -

- a. Type of Payment – EMD or Tender Fees
- b. Bidder Name
- c. PAN of Bidder
- d. Bank Account Number
- e. IFSC Code
- f. Amount in INR
- g. Bank Name
- h. Branch
- i. Contact Person Name
- j. Mobile Number
- k. Copy of cancelled Cheque / Bank Letter
- l. Contract Person mail address

EMD / Tender Form - Tender No. PLHDSJ7350

Type of Payment*
EMD

Vendor Name (As per bank account)*
PETRONET

PAN of Vendor*
AAACP8148D

Bank Account Number*

Verify Bank Account Number*
123456789

Amount in INR*
1

IFSC*
SBIN0000001

Bank Name*
DUMMY

Branch*
DUMMY

Name (contact person name)*
CHARIT

Mobile Number*
8130789224

Attachment - Cancelled copy of cheque/Bank letter*
Choose File CBDT notification.pdf

Email Address (contact person mail id)*
charitgoyal@petronetng.in

I hereby confirm that the above particulars are accurate.

Note: For any issues, please reach out to the admin at emd@petronetng.in
If the challan option is selected on the bank payment screen, please ensure that the RTGS/NEFT payment includes the challan number.
Please refer the concerned tender document for details including the refund policy.

3. Bidder has to certify the filled details, enter captcha and click on Proceed for payment button.

The screenshot displays a web browser window with the URL `petronetlng.in/emd/tender?number=PLHDS/7350`. The page header includes the Petronet LNG Limited logo and navigation menus for 'PLL Corporate', 'Our Businesses', 'Our Commitment', and 'Investors'. The main content area is a form for payment confirmation. It contains the following fields and elements:

- Account Number: SBIN0000001
- Bank Name: DUMMUU
- Branch: DUMMY
- Name (contact person name): CHARIT
- Mobile Number: 8130789224
- Attachment - Cancelled copy of cheque/Bank letter: Choose File (CBDT notification.pdf)
- Email Address (contact person mail id): charitgoyal@petronetlng.in
- Confirmation: I hereby confirm that the above particulars are accurate.
- Note: For any issues, please reach out to the admin at emd@petronetlng.in
- Disclaimer: If the challan option is selected on the bank payment screen, please ensure that the RTGS/NEFT payment includes the challan number. Please refer the concerned tender document for details including the refund policy.
- Captcha: A CAPTCHA image showing the number 7489.
- Text Verification: 7489
- Proceed for Payment button

The footer of the page contains the Petronet LNG Limited logo, a description of services (Regas capacity booking at Dahej Regasification LNG terminal and Ancillary Services of Unloading-Storage-Reloading), and links for Quick Links, Other Links, Contact us, and India Energy Week. The system tray at the bottom shows the date as 16-01-2025 and the time as 11:53.

Kindly note that necessary validations are implemented in field box.

In case all details are not filled properly, then Proceed for Payment button will not be shown.

4. Once the Bidder click on Proceed for Payment button, following webpage will open.

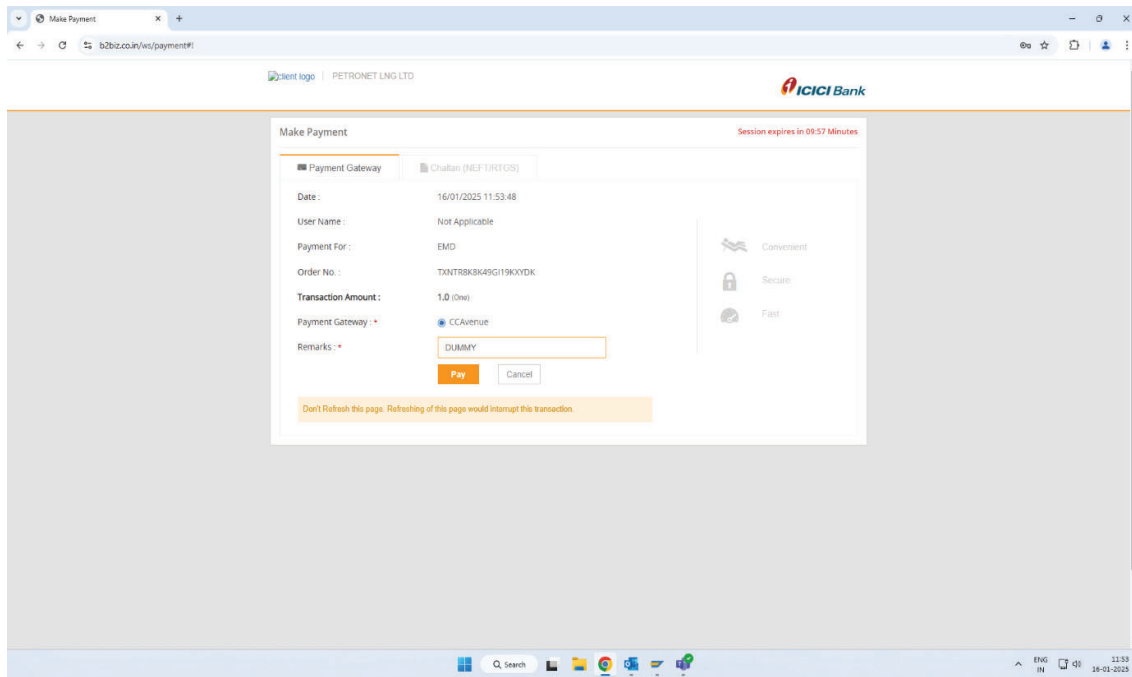

5. Bidder has to select the mode of payment out of the following options: -

a. Payment Gateway

If the Bidder selects Payment Gateway option, then he has to provide **Remarks** and click on **Pay** button. Following webpage will open, where Bidder has to fill the billing information and make the payment from **Net-banking** or **Debit Card** and proceed accordingly.

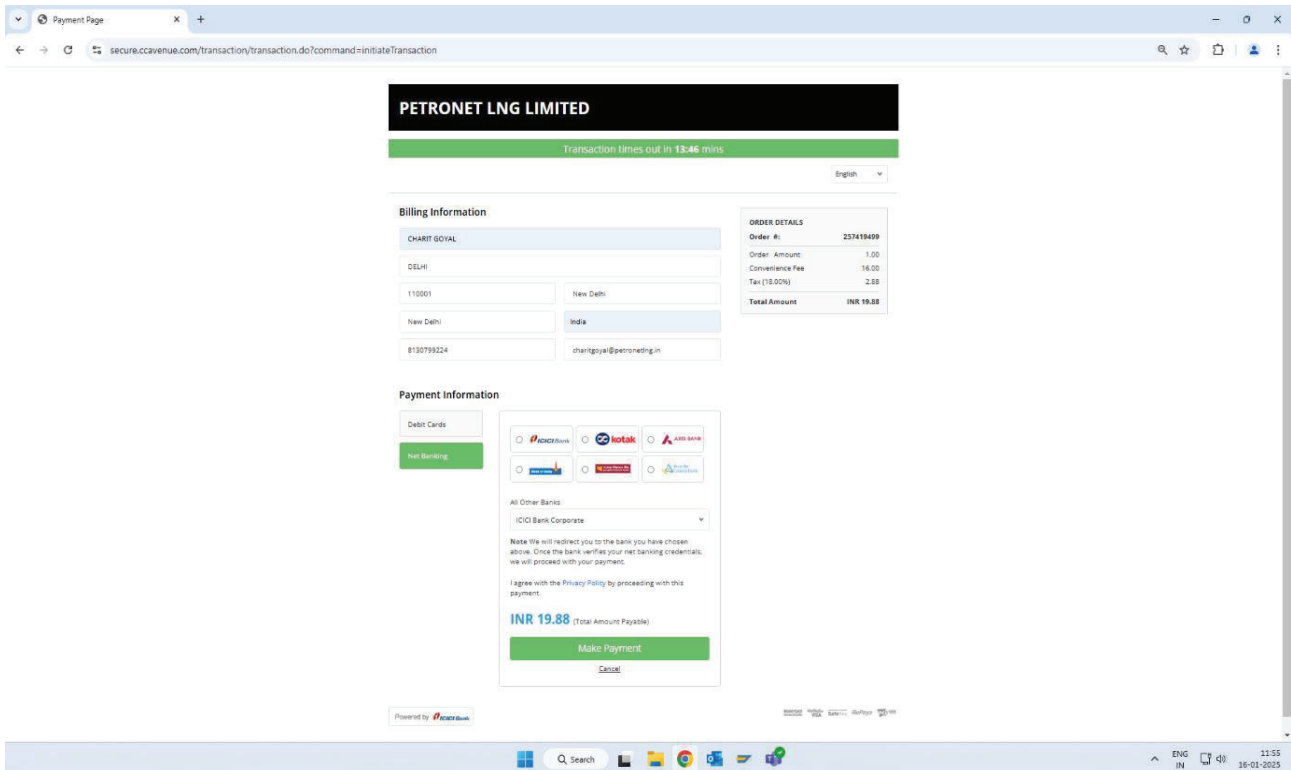

Debit Card

Bidder has to fill the card details and then he will be redirected to the OTP page on Bank's website. Once he enters the OTP, transaction will be completed successfully, and Bidder will be redirected to Petronet EMD page with Payment confirmation message and receipt.

Simultaneously, a system generated mail will be triggered on Bidder's mail id along with Payment Receipt.

Personal Net-banking

Bidder has to click the Net-banking option and select his bank from the list and click on make payment option. Thereafter Bidder will be redirected to the Bank's Net-banking page and login with his credentials and make the payment. Transaction will be completed successfully, and Bidder will be redirected to Petronet EMD page with Payment confirmation message and receipt.

Simultaneously, a system generated mail will be triggered on Bidder's mail id along with Payment Receipt.

Corporate Net-banking

Bidder has to click the Net-banking option and select his bank's corporate portal from the list and click on make payment option. Thereafter Bidder will be redirected to the Bank's Corporate Net-banking page and login with his credentials and create the Cheque/ RTGS/ NEFT instruction. Bidder will be redirected to Petronet EMD page with Payment awaiting message and a system generated mail will be triggered on Bidder's mail id along with pending payment receipt.

Thereafter as per Bidder's SOP in place, transaction need to be authorised by the approvers on the Corporate Net-banking portal. After approval of transaction by the Bidder, status will be updated in the next 30 minutes on Petronet server and a payment success mail will be triggered on Bidder's mail address.

b. Challan Payment

If Bidder select challan payment, a unique challan will be generated, and Bidder will be redirected to Petronet EMD page with Payment awaiting message and a system generated mail will be triggered on Bidder's mail id along with challan.

Thereafter Bidder has to make the NEFT/RTGS payment on the account details provided in the challan generated. After processing of transaction by the Bidder, status will be updated in the next 30 minutes on Petronet server, and a payment success mail will be triggered on Bidder's mail address.

PETRONET LNG LTD	
Date:	09/01/2025 11:19:52
Beneficiary Name:	PETRONET LNG LIMITED PETCHEM ACCOUNT
Beneficiary Account No.:	PTRLNG235610
Beneficiary IFSC:	ICIC0000106
Bank Name:	ICICI Bank
Amount in Figure (in INR):	1.0
Amount in Words (in INR):	One
Reference No.:	TXNCP98XAQBLO985RUK6
Mode of Payment:	NEFT/RTGS
Client Code:	PTRLNG
IP Address &Date:	125.63.96.162 09/01/2025 11:19
Terms &Conditions:	
Please try to make NEFT/RTGS payment atleast one day prior to tender closing.	
Signature of Depositor	
(For BANK'S USE ONLY)	
Date of Transfer:	
Rupees:	
Debited A/c No.:	
Remittance No.:	
Authorised Signatory	
Branch Stamp	
	



1

**SPECIAL CONDITIONS
OF CONTRACT FOR GOODS**



Doc No. B862-SCC-Rev.2

ENGINEERS INDIA LIMITED

SPECIAL CONDITIONS OF CONTRACT

FOR

**PDH PP PLANT WITH ETHANE AND PROPANE HANDLING
FACILITIES AT DAHEJ, GUJARAT PROJECT**

FOR

PETRONET LNG LIMITED

GLOSSARY

CPBG	Contract Performance Bank Guarantee
OWNER	Petronet LNG Limited (PLL)
Bidder/ Vendor	Whom RFQ/ Tender has been issued/ who have submitted offer against RFQ
FOA / LOA	Fax of Acceptance / Letter of Acceptance
FOB / FOT	Free on Board / Free on Truck
PBG	Performance Bank Guarantee
PO	Purchase Order
PRS	Price Reduction Schedule for delayed Delivery
RFQ	Request for Quotations
BDS	Bid Data Sheet
TOV	Total Order Value
SOR	Schedule of Rates / Price Schedule
TPIA	Third Party Inspection Agency

1 INTRODUCTION

1.1 These Special Conditions of Contract (SCC) shall be read in conjunction with the General Conditions of Contract (GCC), Material Requisition and any other document forming part of this RFQ wherever the context so requires.

1.2 Where any portion of the GCC is repugnant to or at variance with any provisions of the SCC & Bid Data Sheet then unless a different intention appears, the provision(s) of the SCC & Bid Data Sheet shall be deemed to override the provision(s) of GCC only to the extent that such repugnancy of variations in the SCC & Bid Data Sheet are not possible of being reconciled with the provisions of GCC for Goods.

2 PAYMENT TERMS

2.1 **Refer BDS for payment terms.**

2.2 NOTES:

- i) 1ST Milestone payment shall be released only after receipt of CPBG (wherever applicable) Wherever ABG is required to be submitted by the supplier against milestone progress payment, validity of ABG shall be valid till 30 days beyond contractual delivery period which shall be further extended, as required till last date of receipt of all material at site. However, ABG will be released on dispatch/ receipt of material at site (as applicable).
- ii) Prorata payments shall be applicable on dispatch of equipment. In case of equipment, prorata shall not be on part of equipment.
- iii) In case of indigenous SUPPLIERS, wherever taxes/duties are separately indicated, the order value shall be exclusive of taxes/duties. 100% payment of GST shall be paid on receipt of GST invoices and on proof of payment of GST or on auto-population under GST portal.
- iv) Payment to indigenous SUPPLIERS shall be released through Electronic Clearing System (ECS) and to foreign SUPPLIERS, payments other than against shipping documents, i.e., for Site Work and Supervision/Training etc. shall be through wire transfer.
- v) **Bidder shall submit Original Invoice to PLL site office in a triplicate.**
- vi) Irrevocable Letter of Credit (L/C) shall be acceptable from foreign Suppliers in place of Advance Bank Guarantee as well as Contract cum Performance Bank Guarantee.
- vii) For payment to Foreign suppliers: L/C shall be established in favor of the supplier in a bank in his country, for an appropriate amount (in line with Payment Terms). L/C shall be opened within 45 days of receipt of acknowledgement of FOA/PO and receipt of CPBG (wherever applicable). In case confirmed L/C is insisted by supplier, L/C confirmation charges shall be to supplier's account.
- viii) All payments (other than through L/C) shall be released within 15 days of receipt of invoice and all requisite documents, complete in all respects.
- ix) All bank charges of respective bankers shall be to respective account.
- x) Supplier shall submit Billing Schedule within three weeks after placement of FOA/PO (whichever is issued earlier) for EIL/OWNER's approval (wherever applicable). Suppliers requiring multiple dispatches will restrict the number of dispatches to maximum Three, unless agreed otherwise by Project Manager.
- xi) In case site front is not available up to 6 (Six) months (wherever site work is applicable), after receipt of all supplies at site, the payment against the site work shall

be released on submission of additional Bank Guarantee of equivalent amount valid for 1 (One) year or such extended period as may be required.

- xii) Certification for placement of sub-order and/or identification of major raw material, in the above payment terms, shall be carried out by the EIL Inspection /Third Party Inspection agency.
- xiii) Wherever the payment provision is there against ABG, and Vendor is not seeking payment against these milestone, those milestone payment shall be released along with milestone of despatch/ receipt of material at site without seeking any ABG for earlier milestone payment.
- xiv) In case of high value Contracts for sophisticated Equipment/ Machinery, if domestic supplier insists payment through LC, this may be considered provided Loading provision is included in Bidding Document.

3 TRANSPORTATION

Clause no. 19 of GCC stands modified to the following extent:

3.1 INDIGENOUS SUPPLIERS

Indigenous SUPPLIERS are required to dispatch the goods on door delivery basis through any registered Transporters on FOT/FOR dispatch point basis or FOT Site basis, as mentioned in RFQ/BDS.

Transportation charges for the items shall be quoted separately as per requirement / scope of MR.

The consignment should be handed over to transporter with E-way bill, wherever required as per law/act. In case such e-way bill is required to be issued by Owner, the concerned designated order issuing authority may be contacted in this regard.

It shall be responsibility of the seller to send intimation immediately on dispatch of the material so that necessary arrangements can be made at site. Delays on account of the same shall solely be attributable to the Supplier.

3.2 FOREIGN SUPPLIERS

Orders in case of foreign suppliers shall be on FOB/CFR Indian seaport of entry basis (JNPT (Nhava Sheva Port) for Containers/ODC & Kandla Port for Break Bulk), wherein the ocean transportation from FOB Port of Exit to the designated Indian Port shall be arranged by the Supplier. All shipments of break bulk material and containerized cargo/ODC shall be made by suitable vessels certified for sea/air worthiness and complying with National/ International safety regulations and age of the vessel being less than 25 years. Bidder to coordinate with PLL nominated Customs House Agent for smooth discharge /delivery of the cargo at the Port of arrival.

Wherever the consignment is required to be shipped by Air (Mumbai Airport for Air Freight), the commercial terms and conditions including INCOTERMS shall be applicable to the extent modified as per BDS.

Bidder shall quote separate prices on FOB Port of Exit basis for Ocean Freight transportation charges. Quoted Ocean freight charges for Break Bulk cargo delivery shall be on FLT (Full Liner Terms), i.e., all charges at destination port shall be borne by the bidder till the cargo is unloaded on to the wharf /vehicle as the case may be. No Trans-shipment is permitted for Break Bulk Cargo/ODC.

Bidder shall inform 07 days prior to the expected date of arrival of vessel in port of entry in India. Detention & Demurrages, if any, due to early arrival of vessel, shall be to bidder's account.

Wherever, the foreign bidder does not accept the ocean transportation in his scope, offer of such bidder shall be rejected.

4 CURRENCY OF QUOTE

4.1 FOREIGN SUPPLIERS

Foreign SUPPLIERS are required to submit prices in one currency out of USD/EURO/GBP/JPY. In case a foreign SUPPLIER is sourcing part of equipment/ services from India, prices of such equipment/ services shall be quoted in Indian Rupees only and terms & conditions applicable to Indian portion shall be as per Annexure-I to this SCC and to be read in conjunction with terms & conditions applicable to Indigenous Suppliers.

Change in currency once quoted will not be allowed.

4.2 INDIGENOUS SUPPLIERS

Indigenous SUPPLIERS are required to submit price in Indian Rupees only.

5 SINGLE POINT RESPONSIBILITY OF THE SUPPLIER

In case of MRs containing supplies as well site work/ services, a single order, covering the supply part as well as site work/ services, shall be placed. Split ordering will not be permitted.

In case, a foreign SUPPLIER requests for a separate order on his Indian sub-SUPPLIER, the same shall not be accepted. However, payment to Indian sub-SUPPLIER shall be released directly in Indian Rupees against invoices duly certified by the Foreign SUPPLIER.

For this purpose, the Indian sub-SUPPLIER's name, material/ services and corresponding price in Indian Rupees, shall be clearly spelt out in the purchase order on foreign SUPPLIER. In case a Foreign supplier sources supplies/ services within India, the applicable terms & conditions shall be applicable to the extent as per Annexure-I to this SPC. However, the vendor is not allowed to change the sub supplier during the course of Contract.

6 CONTRACT CUM PERFORMANCE BANK GUARANTEE (CPBG)

6.1 CPBG shall be required for 10% of the Total Order Value (TOV) for all items.

6.2 Total Order Value shall mean supply price (FOT dispatch point price for Indian bidder and FOB/ FCA price for foreign bidders) plus site work (wherever applicable) plus transportation but excluding GST, supervision services, training, HAZOP, 3D-modeling, AMC.

6.3 Indemnity Bond/Corporate Guarantee in lieu of CPBG shall not be considered. For Foreign bidders, Irrevocable stand by Letter of Credit is acceptable in lieu of CPBG.

6.4 CPBG shall not be applicable for orders where the contract value is less than INR 10 Lakhs.

7 TAXES & DUTIES

7.1 Notwithstanding any prejudice to any other provisions of Bidding Document, provisions of Annexure-II of SCC shall be read in conjunction with Clause No. 30 of GCC.

8 FIRM PRICES

8.1 The prices shall be firm and fixed and not subject to any variation, except statutory variation in taxes and duties & imposition of new taxes as per Annexure II.

8.2 In case of Electrical and Instrumentation Cables, variation in prices shall be admissible as per IEEMA Price Variation Clause. [Refer BDS for applicability of the same]. However, price variation shall be restricted to ceiling of +10 % and no ceiling limit in case of negative variation.

8.3 For 2 years O&M spares, prices shall be kept valid for a period two years from the final bid due date.

9 PRICE REDUCTION SCHEDULE (PRS)

9.1 Price Reduction Schedule shall be as per clause no. 10 of “General Conditions of Contract”.

9.2 Wherever the supply period and site work are indicated as two separate periods and notice of site readiness is required for site work, intervening period, if any, shall be excluded, while calculating the price reduction for delay.

9.3 Price reduction shall be affected in the Invoice value before presenting for payment.

9.4 For the purpose of PRS, a delay for a period less than one week shall be considered as delay for the full week.

9.5 Total order value shall mean Supply value plus Site Work value (if applicable) including any amendments/ change order but excluding GST. However, in case of Short Closure/ cancellation, the order Value shall be executed/ supplied value plus the actual cost of work done at the risk & cost of the supplier plus EIL overhead charges.

10 INSPECTION

10.1 Inspection of Indigenous items shall be done by EIL and supplier need not consider these charges while quoting. In the case Indian party sourcing materials from abroad, the bidder shall arrange inspection through Third Party Inspection agency in the country of origin & charges of the same shall be included in quoted prices

10.2 Foreign vendors shall include inspection charges of Third Party Inspection agency in the country of origin. In the case of foreign party sourcing items from India the inspection shall be by EIL, no additional charges shall be payable to seller on account of the same.

10.3 List of approved TPI agencies:

- a) M/s TUV SUD South Asia Pvt. Ltd.
- b) M/s TUV Rheinland (India) Pvt. Ltd.
- c) M/s TUV India Pvt. Ltd. / TUV Nord Group (TUV)
- d) M/s Apave Assessments India Pvt. Ltd. (AAIPL)
- e) M/s VCS Quality Services Pvt Ltd
- f) M/s DNV
- g) M/s IR Class Systems and Solutions Pvt Ltd
- h) M/s Projects & Development India Ltd (PDIL)
- i) M/s Tata Projects Ltd
- j) M/s Llyods Register (LRS)
- k) M/s Bureau Veritas (BV)
- l) M/s Société Générale de Surveillance (SGS)
- m) M/s Gulf Lloyds Industrial Services (GLI)
- n) M/s International Certification Services (ICS)
- o) M/s Bureau Veritas (Ind.) Pvt. Ltd (BVIS)
- p) M/s Intertek India Pvt. Ltd.
- q) M/s Moody International (Moody)
- r) M/s RINA India Pvt. Ltd.
- s) M/s Competent Inspectorate and Consultants LLP
- t) M/s ABS Industrial Verification (India) Pvt. Ltd.
- u) M/s Certification Engineers International Ltd (CEIL)
- v) M/s SGS India Pvt. Ltd.

Note: TPI Agencies listed above can depute their foreign counterparts of their respective country, where the inspection needs to be carried out for material/equipment

being supplied by the foreign vendor.

10.4 Seller to note the following:

- a) ITP / QAP will be approved by EIL Inspection/Third Party Inspection agency incorporating requirements of ITP, Technical specifications and approved documents as per PR.
- b) The Inspection release note issued by the EIL Inspection /Third Party Inspection agency shall clearly stipulate that materials/equipment have been inspected as per Code-1 approved drawings and approved ITP /QAP.
- c) Certification of final documents, wherever applicable, for release of final payment, shall be carried out by EIL Inspection /Third Party Inspection agency issuing the final inspection certificate as per PR.
- d) Based on indicative inspection and test plan identifying scope of inspection / review of document as minimum requirement, detailed inspection and test plan indicating all specified requirement of Purchase Requisition to be generated by vendor and same duly approved by TPIA to be submitted to EIL/Owner for approval.
- e) The price quoted by the bidder shall be inclusive of all IBR/IGC/NACE charges (if applicable) and all statutory certification charges PESO/CCOE etc. (if applicable) as required in the Material Requisition.

11 **COMPREHENSIVE MARINE-CUM-ERECTION INSURANCE**

11.1 Clause no. 18 of GCC stands modified to the following extent:

Comprehensive Insurance (Transit/ Marine cum storage, erection, till handing over of equipment) shall be arranged by PLL. Therefore, the same shall not be included in the quoted prices. However, all transit insurance up to FOB / FCA International Sea / Air Port of Exit must be included in the quoted Price.

12 **BASIS OF EVALUATION**

12.1 **WHERE ONLY INDIAN BIDS ARE UNDERCOMPARISON**

- 12.1.1 FOT dispatch point price, Cost of mandatory spares, if identified in the Material Requisition, commissioning spares and special tools & tackles, road freight for price evaluation of bids, but GST, cost of Spares for two years operation & Unit rates of addition/deletion shall be excluded.
- 12.1.2 AMC charges excluding GST thereon shall be considered for evaluation, wherever AMC is required.
- 12.1.3 Supervision (man days as indicated in enquiry document), Training, Hazop, 3D-modeling charges, any other charges excluding GST thereon shall be considered for evaluation wherever these services are required.
- 12.1.4 Site Work charges excluding GST thereon shall be considered for evaluation, wherever applicable.
- 12.1.5 Technical & Commercial loading, if any, shall be considered for evaluation of bids.

12.2 **WHERE ONLY FOREIGN BIDS ARE UNDER COMPARISON**

- 12.2.1 Bids shall be evaluated on the basis of CFR (JNPT (Nhava Sheva Port)) prices including, stowage charges wherever applicable (as quoted by BIDDERS), and considering sea freight as quoted by the bidder.

In case of pipes, if a foreign bidder has not quoted or not included stowage charges, the same shall be loaded @ 10% of bidder's quoted Ocean Freight.

- 12.2.2 Cost of mandatory spares identified in the Material Requisition, Commissioning Spares and

special tools & tackles will be included for evaluation of bids, but costs of Spares for two years operation & Unit rates of addition/deletion shall be excluded.

- 12.2.3 AMC charges excluding GST thereon shall be considered for evaluation wherever AMC is required.
- 12.2.4 Site Work excluding GST thereon, wherever applicable shall be considered for evaluation.
- 12.2.5 Supervision (man days as indicated in enquiry document) and Training charges excluding GST thereon shall be considered for evaluation, wherever, supervision and training are required.
- 12.2.6 Technical & Commercial loading, if any, shall be considered for evaluation of bids.
- 12.2.7 Income tax payable in India, in case foreign bidder quotes net of taxes.
- 12.2.8 For global enquiries, for evaluation and comparison purposes, the currency(ies) of the Bid shall be converted into a single currency i.e., INR, and the declared rate of exchange (Bills selling rate of State Bank of India) one day prior to the due date of opening of priced bids shall be considered, for conversion purpose.

Note: Wherever any one of the foreign bidders has opted for concessional rate of duty (Multi-Lateral or Bi-Lateral trade agreement between India and bidder's country), the evaluation shall be carried out in line with clause 12.3.2 (v).

12.3 WHERE INDIAN AS WELL AS FOREIGN BIDS ARE UNDER COMPARISON

12.3.1 INDIGENOUS BIDDERS:

The evaluated price of indigenous BIDDERS shall be carried out on the basis of landed cost at Site, as per clause 12.1 above.

In addition to above a notional loading @ 1% of FOT dispatch point price towards inspection charges by EIL shall be applied.

12.3.2 FOREIGN BIDDERS:

The evaluated price of foreign BIDDERS shall be on the basis of landed cost at Site, including the following:

- i) Evaluation shall be done as per clause 12.2 above
- ii) Marine insurance @ 1% of FOB Price.
- iii) Applicable Customs duties considering prevailing applicable Merit rate of Basic Custom duty or Basic Custom duty as per Multi-Lateral or Bi-lateral agreement etc., (if declared by bidder)] on CIF value.
- iv) Custom clearance and Port Handling charges@ 2% of CIF value
- v) Inland Freight (from Port of Entry (JNPT (Nhava Sheva Port)) to PLL Dahej project site) charges @ 2% of the aggregate cost at S. No. (i) to(iv).
- vi) In case inspection is done by EIL, a notional loading @ 1% of FOB price towards inspection charges by EIL
- vii) L/C charges @ 0.25% of FOB price.

Landed Cost at Project Site = S.No. (i) to (vii).

NOTE: Transit insurance for Indigenous and Foreign BIDDERS for transportation within India, will not be loaded (being in PLL scope).

12.4 GENERAL

- 12.4.1 Taxes and duties will be cost loaded as quoted by the bidder. However, if a SUPPLIER

states that taxes/duties are not applicable at present and will be charged as applicable at the time of delivery, then his bid shall be loaded by the maximum rate of taxes/duties applicable at the time of evaluation of Bids.

- 12.4.2 Notwithstanding anything mentioned elsewhere in the Bidding Document, the aggregate liability of Owner towards Payment of Taxes & Duties shall be limited to the volume of GST declared by the bidder in its bid & nothing shall be payable extra except for the statutory variation in taxes & duties & any other taxes & duties mentioned elsewhere in the bidding document.
- 12.4.3 In case the bidder is covered under Composition Scheme under GST laws, then bidder should quote the price inclusive of the GST (CGST & SGST/UTGST or IGST). Further, such bidder should mention "Cover under composition system" in column for GST (CGST & SGST/UTGST or IGST) of price schedule/proposal form.
- 12.4.4 In case of two different charges are indicated for additional services like freight, TPI etc. or charges are quoted in %age as well as lumpsum charges and both works out to be different, higher between the two shall be considered for evaluation. If the bidder happens to be L1 with the higher charges, lower value shall be considered for the award.

13 LOADING/REJECTION CRITERIA

No loading criteria on account of commercial deviation will be applicable.

Bids shall be invited on Zero Deviation bidding basis. Deviation to terms & conditions to RFQ shall lead to rejection of offer.

14 TRANSFER OF PROPERTY FROM THE SELLER TO THE PURCHASER

The transfer of property shall be deemed to have taken place as follows subject to the provisions herein contained:

- a) FOB/FCA/CFR Contracts: In the case of FOB/FCA, CFR & CIF Contracts, when the Goods have been put on board of ship, at the specified port of loading and a clean Bill of Lading / Airway Bill is obtained.
- b) F.O.T. despatch point: On handing over the equipment to the carrier against receipt (LR) along with Inspection Release Note (IRN) and such document having been passed over to the Purchaser.
- c) F.O.T. Project Site: on receipt of material at Project site.
- d) Equipment sent freight/ carriage paid to the Project site: On receipt of goods at site.
- e) Equipment erected by the Seller: on acceptance at job site.
- f) Equipment commissioned by the Seller: On taking over by the Purchaser for regular operation after test run at maximum capacity for specified period satisfactorily performed.

15 FALL CLAUSE

Clause no. 28 of GCC applicable is case of NOMINATION AND PROPRIETARY AWARD.

16 PART ORDER

16.1 Bidder hereby agrees to accept part order at Purchasers option without any limitation whatsoever.

16.2 Any charges quoted extra as lumpsum shall be applicable prorata on value basis in the event of part order.

17 REPEAT ORDER

17.1 Repeat Order shall be as per clause no. 24 of GCC.

17.2 Non-Acceptance of Repeat Order conditions by bidder shall not be the reason for rejection

of bid.

18 DISPATCH NUMBER

18.1 In addition to the details furnished in the invoice, supplier shall generate DISPATCH NUMBER (DN) against each invoice. The DN shall be 3 digit continuous number starting from 001 suffixed to purchase Order Number and shall be unique to each invoice. Same shall also be printed on each consignment / box for easy co-relation. DN shall be quoted in all further communications viz dispatch detail to inspection, correspondence with site as well as for payment purpose. Mentioning the DN on each invoice shall be mandatory.

19 TERMS & CONDITIONS FOR SUPERVISION OF ERECTION, TESTING & COMMISSIONING / TRAINING AT SITE/HAZOP STUDY

19.1 Terms & conditions for supervision of erection, testing & commissioning / training at site shall be as per attached Annexure-III to SPC.

20 TERMS & CONDITIONS FOR INSTALLATION / SITE WORK

20.1 Terms & conditions for installation/ site work shall be as per attached Annexure-IV to SPC.

21 TERMS & CONDITIONS FOR ANNUAL MAINTENANCE CONTRACT (AMC)

21.1 Terms & conditions for Annual Maintenance Contract (AMC) shall be as per attached Annexure-V to SPC.

22 TERMS & CONDITIONS FOR TRAINING OF OWNER PERSONNEL AS PER MR AT VENDOR'S WORKS / TRAINING FACILITY

22.1 Terms & conditions for training of owner personnel as per MR at vendor's works/ training facility shall be as per attached Annexure-VI to SPC.

23 WARRANTY:

23.1 The Seller will guarantee that all materials and equipment shall be repaired or replaced as the case may be, at his own expense, in case the same have been found to be defective in respect of material, workmanship or smooth and rated operation within a period 12 months after the equipment/ material have been put in service or 24 months from the date of shipment, whichever is earlier. Repaired or replaced equipment/ materials shall be similarly guaranteed by the SELLER for a period of twelve (12) months from the date of replacement/ repair subject to a maximum of 24 months from the date, the main equipment/ material has been put in service. All expenses for such replacement/ repair of equipment/ material shall be to the account of the Seller including freight, if any."

24 RECOVERY OF SUMS DUE:

Clause No. 25 of GCC stands modified to the following extent:

The phrase "(he is hereby irrevocably authorized to do so)" stands DELETED

Annexure I to SCC

TERMS & CONDITIONS FOR INDIAN SOURCED COMPONENTS BY FOREIGN BIDDER

Foreign bidder may source components / sub-supplies and services from India, if allowed as per Material Requisition. For such sub-supplies / services, Commercial Terms & Conditions of the RFQ shall stand modified to the following extent:

1. PRICING:

- 1.1 Unit and total price on FOT Despatch Point basis including packing and forwarding charges.
- 1.2 Details of Taxes and duties (rates) payable extra on the finished goods, applicable on Indian sub-suppliers.
- 1.3 Separate and clear break-up of charges for inland transportation is to be quoted by the bidder.
- 1.4 Materials if ordered against the RFQ are required to be dispatched on door delivery basis.
- 1.5 Transit insurance of Indian sub-supplies shall be borne and arranged by the PLL.
- 1.6 Indian counterpart of Foreign Bidder shall procure the items from EIL enlisted suppliers.

2. CURRENCY OF QUOTE:

The quoted price of sub-supplies shall be in Indian Rupees only.

3. AWARD OF ORDER:

Foreign Principal shall be the single point responsible Vendor and separate order on foreign supplier and Indian sub-supplier / sub-contractor is not acceptable. Single Purchase order shall be issued on the foreign principal clearly indicating the sub-supplier's / sub-contractor's name, material and corresponding price in Indian Rupees.

4. DELIVERY:

The delivery period for sub-supplies shall be on FOT site basis within specified delivery period for foreign bidder as per Terms of RFQ/Bidding document.

5. PRICE REDUCTION SCHEDULE:

PRS shall be applicable in totality on foreign scope + Indian sourced component / site work for delay in supply of goods/ site work either by foreign principals or Indian counterpart.

6. PAYMENT TERMS:

Payment of Indian sub supplies:

- 85% through E-Payment with taxes and duties will be paid against receipt of Indian sourced goods/material at Project Site.
- 10% against receipt of Indian supplies at site and delivery of main equipment by foreign bidder, as per Terms of bidding document and completion of site work, wherever applicable.
- 5% on submission of Final/As built Drawings/Documents/Data/Manual in requisite number of copies/sets/CDs as per VDR specified in Purchase Requisition, by main bidder.

Payment of Indian services:

- Shall be as per BDS.

Note:

- Payment of Indian sub supplies/Services shall be released directly to Indian counterpart against Invoices raised by Indian counterpart duly certified by foreign principal.
- In case of Foreign bids with Indian sub supplies, the payment terms of Foreign bidder against shipping documents stands reduced by 5% which shall be released as follows:

5% payment shall be released thru wire transfer, on delivery of main equipment by foreign principal (as per terms of enquiry document) as well as receipt of Indian supplies at site.
- The payments shall be made after adjustment of Price Reduction Schedule.
- If foreign principal delivers all their foreign sourced goods with Indian sourced delivery yet to be completed and further requests for release of last 10% payment, then this last 10% shall be released to foreign principal by PLL against the submission of bank guarantee for this 10% of order value valid for 03 months from CDD plus 1 month claim period or till completion of Indian sourced items, whichever is later.

7. CONTRACT PERFORMANCE BANKGUARANTEE:

Foreign principal shall submit the Contract performance bank guarantee for 10% of Total Order Value including value of foreign portion and Indian sourced components / site work.

TAXES & DUTIES

A. Price basis w.r.t inclusion/exclusion of taxes and duties

1. The quoted price(s) shall be inclusive of all the taxes and duties except GST (i.e. IGST or CGST and SGST/UTGST applicable in case of interstate supply or intra state supply respectively) and GST compensation cess, (if applicable) leviable on sale of finished goods/services.
2. In case of foreign bidders, bidders shall submit their prices on FOB international sea port of exit basis/CFR on destination port basis (INCOTERM 2020), unless otherwise stated in the bid document. FOB/CFR prices quoted shall be inclusive of all applicable taxes up to FOB international sea port of exit/CFR on destination port basis.
3. Transportation charges (if applicable) up to respective project site shall be exclusive of GST.
4. Site work prices, if applicable shall be inclusive of all taxes and duties except GST. All necessary registrations, if required, for carrying out the site activities shall be done by the bidder and costs towards the same shall be included in quoted site work prices.
5. Prices of per diem supervision charges, training/AMC, HAZOP Study etc. (as applicable) shall be exclusive of GST. However, GST shall not be applicable on training provided at foreign bidder's work/training facilities in any territory other than India.

B. TAX CLAUSES

1. Goods and Services Tax

- a. The supplier/contractor will be liable to register with the respective tax authorities and to submit self-attested copy of such registration certificates and the supplier/contractor will be responsible for procurement of goods/services in its own registration (GSTN).
- b. Supplier/Contractor shall be required to issue tax invoice in the form and manner prescribed under GST Act read with Rules thereunder including E-Invoicing provisions so that input tax credit under GST can be availed by Owner. In the event that the supplier/contractor fails to provide the Tax Invoice/E-Invoice in the form and manner prescribed under the GST act read with GST invoicing rules thereunder, Owner shall not be liable to make any payment on account of GST against such invoice.
- c. In case supplier/contractor is not subject to E-Invoicing provisions under the GST Laws as amended from time to time, then a declaration to this effect

shall be furnished by the supplier/contractor in format prescribed along with the Invoice.

- d. GST shall be paid to supplier/contractor against receipt of Tax Invoice/E-Invoice and on auto-population of input tax credit on GSTN portal. In case of non-receipt of Tax Invoice/E-Invoice and/or non-auto-population of input tax credit on GSTN portal, Owner shall with hold the payment of GST.
- e. The supplier/contractor shall always comply with the requirements of applicable laws and provide necessary documents as prescribed under the rules and regulations, as applicable from time to time. In particular, if any tax credit, refund or any other benefit is denied/delayed to Owner or any interest/penalty is charged to Owner due to any non-compliance/ delayed compliance by the supplier/contractor under the GST Law (including but not limited to failure to upload the details of the sale on GSTN portal, failure to pay GST to the government or due to non-furnishing or furnishing of incorrect or incomplete documents, non-filing of GST return by the supplier/contractor), the supplier/contractor shall be liable to reimburse Owner for all such losses and other consequences including but not limited to the tax loss, interest and penalty. Owner shall be entitled to recover such amount from the supplier/contractor by way of adjustment from the next invoice, encashment of BG or by way of any other means either of same project or any other project of the Owner.
- f. In case of any Advance including Mobilization/Secured/Other Advance is granted to supplier/contractor as per the provisions of Contract, then the supplier/contractor shall issue a Receipt Voucher / GST Invoice in the form and manner prescribed under GST Act read with Rules thereunder including e-invoicing provisions.
- g. In case of any Price Variation as per the provisions of Contract, the supplier/contractor shall issue an Invoice in the form and manner prescribed under the GST Act read with Rules thereunder including e-invoicing provisions.
- h. GST payable under reverse charge for specified services/goods under GST Act read with Rules thereunder, if any, shall not be paid to the supplier/contractor but will be directly deposited by Owner to the appropriate Government Tax Authority. If the same has already been reimbursed / paid to the supplier/contractor for any reason whatsoever, then Owner shall be entitled to deduct/set off /recover such amount against any amounts paid/payable by Owner to supplier/contractor.

-
- i. Where Owner has the obligation to discharge GST liability under reverse charge mechanism and Owner has paid or is liable to pay GST to the government on which interest/penalty becomes payable as per GST law for any reason which is not attributable to Owner or Input Tax Credit w.r.t. such payment is not available to Owner for any reason which is not attributable to Owner, then Owner shall be entitled to deduct/set off /recover such amount against any amounts paid/payable by Owner to contractor/supplier.
 - j. TDS under GST, if applicable shall be deducted from supplier/contractor bills at applicable rates and a certificate as per rules for tax so deducted shall be provided to supplier/contractor.
 - k. The supplier/contractor will be under obligation for charging correct rate of tax as prescribed under the respective tax laws. Further the supplier/contractor shall avail and pass on benefits of all exemptions/concessions available under applicable tax laws.
 - l. In case bidder is covered under composition scheme under GST law, then bidder shall quote the price inclusive of GST. Further, such bidder should mention "Covered under GST Composition Scheme" in column for GST of relevant price schedule(s). In case subsequently such bidder gets covered under regular GST regime, the prices including GST under regular GST regime shall not exceed the prices quoted by the bidder under composition scheme.
 - m. Owner prefers to deal with registered supplier/contractor of goods/services under GST. Therefore, bidders are requested to get themselves registered under GST, If not registered yet. However, in case any unregistered bidder is submitting bid, their prices will be loaded with applicable GST while evaluation of bid as per evaluation methodology of tender document. However, where Owner is entitled for input credit of GST, the same will be considered for evaluation of bid as per evaluation methodology of tender document.
 - n. In case of foreign bidders, for supervision/site-work/training, services provided by foreign bidder at project site, GST shall be paid by Owner directly to appropriate Government Tax Authorities, under Reverse Charge Mechanism, if applicable and price of such services will be loaded with applicable GST while evaluation of bid as per clause E (Evaluation methodology).
 - o. Bidder will be required to quote applicable tax rate (along with applicable HSN/SAC Code) as per provisions of GST Laws for all the line items forming part of the enquiry. Any higher rate of tax actually invoiced in excess of

quoted rate of tax (except in compliance with provisions of Statutory Variation clauses) shall be adjusted in basic price.

- p. In case of delay in supply/execution of contract, supplier/contractor shall be liable to raise invoices for reduced value as per Price Reduction Schedule (PRS) provision of the bidding document. In case the supplier/contractor raises invoices for full value, then supplier/contractor shall issue Credit Note, in the form and manner prescribed under relevant GST Act read with Rules thereunder, towards applicable PRS amount with applicable GST thereon.

In case supplier/contractor fails to submit invoices with reduced value or does not issue Credit Note as mentioned above, Owner shall release payment to the supplier/contractor after giving effect to the PRS clause with corresponding reduction in taxes from invoice(s) of supplier/contractor.

In case any financial implication arises on Owner due to issuance of invoice without reduction in prices or non-issuance of Credit Note by supplier/contractor, the same shall be to the account of supplier/contractor. Owner shall be entitled to recover the amount of such financial implication paid or becoming payable by Owner together with penalty and interest thereon, if any.

- q. E-way bills shall be issued directly by supplier/contractor in all cases except in cases of direct imports by Owner where E-way bill shall be issued by Owner.
- r. In case of applicability of any recovery as per provisions of the contract, Owner shall raise Invoice on supplier/contractor after charging GST at applicable rates as per prevailing provisions of GST Laws.

2. IMPORT DUTIES

- a. Direct supplies by foreign suppliers where, client becomes consignee :
- i. Consignee shall be Owner, bill of entry shall be filed by Owner, all import duties, Social Welfare Surcharge, IGST and GST Compensation Cess etc. as applicable in India shall be paid by Owner.
- b. Imported supplies by Indian suppliers as built in import content where Suppliers/Contractors will become consignee of the goods by filling Bill of Entry for Home consumption
- i. Custom duties, Social Welfare Surcharge, IGST, GST Compensation Cess, etc. as applicable in India on the imported materials shall be included in the quoted prices by the bidder (considering the input tax credit of IGST, GST Compensation Cess on imported material) and supplier/contractor shall be responsible for the timely payment of the

-
- custom duties to the relevant government authority. All harbor dues/ pilotage fees, port fees, wharfage, unloading costs, demurrage charges etc. incurred in India in respect of any imported goods shall be to supplier's/contractor's account.
- ii. Bidder to indicate, in relevant price schedule, CIF value of built-in import content and applicable merit rate of custom duty, Social Welfare Surcharge on custom duty (considering the input tax credit of IGST, GST Compensation Cess on imported material) included in quoted price, in the price schedule.
 - iii. In case merit rate of custom duty is applicable and bids are invited on the basis of same, however at a later stage concessional rate of custom duty becomes applicable, concessional certificate shall be issued towards import of material against the advance request letter submitted by the domestic bidder and the differential custom duties between concessional rate and quoted merit rate of custom duty by supplier/contractor shall be passed on to the Owner or it shall be recovered by the Owner from the supplier/contractor's invoice.
 - iv. The supplier/contractor shall be responsible for and shall exercise due diligence in properly classifying the goods and materials, undertaking the payment of custom duties, and/or otherwise complying with all applicable laws w.r.t. import of the goods and materials.
 - v. If bidder does not furnish built in CIF value and rates of custom duty, in that case bidder shall not be entitled to claim any variation in the custom duties even if bidder has quoted their prices considering custom duties.
 - vi. If custom duty rate actually paid on import of materials and components is found to be lower than the quoted rate of custom duty, then benefit of the same shall be passed on to the Owner.
 - vii. If bidder has considered Import Duty other than Merit Rate of Import Duty then statutory variation on the Import Duty shall be payable extra on the Merit Rate of Import Duty or the rate of Import Duty considered by the bidder, whichever is lower.
 - viii. In case, no import is made for execution of the order, clauses related to Imports will not be applicable.
- c. General points:
- i. In case Owner is exposed to any penal action, interest /penalties by the custom authorities for incorrect declaration and / or valuation of the goods or material by the supplier/contractor, or otherwise on account of any breach of applicable laws in the course of the import of the goods and material by supplier/contractor, the supplier/contractor shall indemnify and hold harmless the Owner for any and all costs, expenses or losses suffered or incurred by Owner in this regard

-
- ii. If bidder intends to source import of goods from a country with which India has Free Trade Agreement (FTA) or Comprehensive Economic Partnership Agreement (CEPA) or any such multi-lateral / bi-lateral Agreement or Treaty with India or under Generalized System of Preference (GSP); or under any other notification (allowing lower rate of custom duty), then the bidder is advised to ascertain and confirm its applicability along with supporting documents in the bid and ensure that conditions of such agreement/treaty etc. are strictly complied with.
 - iii. The bidder shall be liable to provide all documentation to ensure availment of the exemption/waiver. In case the bidder defaults on this due to any reason, whatsoever, he shall be liable to bear the incremental custom duty applicable if any
 - iv. Any additional custom duty applicability on account of any change in the notification (allowing lower rate of custom duty)/ CEPA/FTA/multi-lateral/bi-lateral trade agreement shall be to bidder's account.
 - v. Documentation to be furnished for availing the exemption /waiver of custom duty shall be specifically listed in the letter of credit also as a prerequisite for release of payment against shipping documents and this documentation shall necessarily form a part of shipping documents.
 - vi. Owner will not bear any liability towards payment of Safeguard Duty, Anti-Dumping Duty, Protective Duty and applicable IGST including GST Cess on same or Countervailing Duty on subsidized articles or any other such duties of Customs imposed by Government under Customs Tariff Act, 1975.
 - vii. In case custom duty rate as quoted by Foreign bidder is less than Actual rate applicable on due date of submission of last price bid and payment of custom duty is on Owner's Account, differential amount on account of above-mentioned rate variation will be recovered from Foreign bidder.

3. INCOME TAX

a. Foreign supervisors/suppliers/contractors

Prices of site work, contracts and other services of foreign supplier/contractor shall be gross of income tax i.e., inclusive of Indian

income tax at the applicable prevailing rate as per Indian Income Tax Act and Rules there under.

Owner shall deduct withholding tax at source (TDS) as applicable while making payments against each invoice. Certificate for TDS shall be provided to the supplier/contractor.

In case foreign bidder quotes Prices of site work, contracts and other services “net of Income Tax” i.e., exclusive of Indian income tax, Owner shall deduct and deposit TDS as applicable after grossing up the sums due while making payments against each invoice at the applicable prevailing rate as per Indian Income Tax Act and Rules thereunder.

Foreign bidder shall furnish the information required in line with the prevalent provisions of Income tax act read with rules thereunder including but not limited to Tax residency certificate, Form 10F, No permanent establishment declaration, No business connection certificate, PAN in India if available.

Failing to provide above documents/information, tax will be withheld at rates applicable as per the provisions of Income Tax Act, 1961 read with rules thereunder and the benefit of reduced rates will not be given.

If the non-resident is unable to obtain & submit Tax Residency Certificate to the Owner within a reasonable time, the bidder should furnish Form 10F along with an undertaking to the effect that the bidder is a tax resident of (the specified country) and that they shall obtain and provide the tax residency certificate (TRC) to the Owner before 30 days of submission of first Invoice by them or within 3 months from the date of entering into contract whichever is earlier.

In case of contracts with term exceeding one financial year, the relevant documents like TRC, Form 10 F, No PE / Business Connection Certificate etc. as applicable, as per Income Tax Act, 1961 must be submitted at the beginning of each financial year and the Owner will not bear additional tax liability (if any) arising from non-submission of documents.

The bidder shall be liable to intimate the subsequent changes (if any) to the information submitted against any of the above particulars, along with full details.

In addition to the above particulars, the bidder should also provide any other information as may be required at a later stage for determining the taxability of the amount to be remitted to the non-residents.

In case, any additional tax liability arises on the Owner due to any action of bidder like delay in submission / non-submission of information / documents required as above or change in residential status post submission of documents or change in any document (like TRC, Form 10F etc.) after its submission shall be recovered from the supplier/contractor.

b. Indian resident supervisors/ suppliers/contractors

Prices for supply and services of Indian suppliers/ contractors shall be inclusive of income tax.

Tax shall be deducted at source (TDS) by Owner on all sums due to supplier/contractor in accordance with the provisions of Indian Income Tax act read with rules thereunder as in force at the relevant point of time.

Owner shall issue a Tax Deduction Certificate to the supplier/contractor evidencing the tax deducted or withheld and deposited by Owner on payments made to the supplier/contractor to enable the supplier/contractor to claim the credit of Tax deducted by Owner.

c. INCOME TAX (General Points):-

- i. The supplier/contractor shall also be responsible for ensuring compliance with all applicable provisions of the Direct Tax Laws of India including, but not limited to, the filing of relevant Tax Returns and shall promptly provide all information required by the Owner for discharging any of its responsibilities/liabilities under such laws in relation to or arising out of the Contract. For the lapses/failure, if any, on the part of the supplier/contractor and consequential penal action taken by the Income Tax department, Owner shall not take any responsibility whether financial or otherwise and shall be indemnified by the supplier/contractor.
- ii. The Indian Income Tax Act and Rules made thereunder contains provisions permitting deduction of tax at source (TDS) at lesser rate if the supplier/contractor is able to justify to the Income Tax Authorities such lesser rate of deduction. However, a deduction once made has to be deposited by the Owner with the Income Tax Authorities in India and will not be adjustable by the Owner. It is therefore in the interest of the supplier/contractor that prior to release of any payment due to the supplier/contractor under the Contract that the supplier/contractor obtains from the relevant Income Tax Authorities in India, a certificate specifying the rate of deduction/withholding of Income tax at source, failing which, payment to the

supplier/contractor shall be made by the Owner after withholding/deduction at the rate as may be applicable to the supplier/contractor as per provisions of Income Tax Act, 1961.

- iii. TDS on interest recovered on Mobilization/Other Advance will be deposited by the supplier/contractor and same would be reimbursed by the Owner against submission of Form-16A (TDS certificate).

C. INVOICING METHODOLOGY W.R.T. TAXATION

following invoicing methodology shall be applicable:

1. In case of domestic / foreign PO's (Other than 2 below) , Invoice/E-Invoice shall be raised by the supplier/contractor in the name of Owner and consignee shall be Owner.
2. In case of package MR's (where title transfer or take over is envisaged to take place at site after completion of site work) and tenders, supplier/contractor shall bring material at project site in their own name and they themselves shall be consignee. As per provisions of contract between Owner and supplier/contractor, Invoice/E-Invoice shall be raised by supplier/contractor to Owner after charging GST.

D. APPLICABILITY OF TAX CREDIT

GST input credit is available to Owner.

E. EVALUATION METHODOLOGY W.R.T. TAXES

Following shall be loaded for evaluation:

1. Applicable Custom Duty, Social Welfare Surcharge etc, (excluding IGST & GST Compensation Cess (if applicable) on imported material which shall be dealt as per bid evaluation methodology given in E2 below) shall be loaded for price bid evaluation in respect of supplies for which bill of entry has to be filled by Owner.
2. GST on which input credit is not available to Owner including GST Compensation Cess (if applicable).
3. Applicable Income tax, in case foreign bidder quotes prices net of taxes.

F. TAXATION TERMS FOR INDIAN SOURCED SUPPLIES (Applicable in case of foreign supplier)

Shall be the same as applicable for Indian bidders.

G. TAX IMPLICATION WHERE FABRICATION YARD IS OUTSIDE THE FACTORY PREMISES, WHEREVER APPLICABLE

In case of package MRs and tenders, since contractors/suppliers shall bring material at project site in their own name and raise invoice to Owner (as per payment milestone achieved) after charging GST, location of fabrication yard whether inside or outside factory premises will not attract any additional liability.

H. TAX IMPLICATION WHERE OWNER WILL ISSUE FREE ISSUE MATERIAL (FIM) TO CONTRACTORS/SUPPLIERS

Where Owner issues FIM's to suppliers/contractors, material will be released against delivery challan and such FIM shall be received back in factory premises as per provision of GST.

I. STATUTORY VARIATION

No variation on account of taxes and duties, statutory or otherwise, shall be payable to Supplier/Contractor except for the following:

1. GST: If after the due date of submission of last price bid and up to the contractual delivery/completion period (*Note 4), any increase/decrease occurs in the applicable rate of GST, the variation in such GST shall be to Owner's account and shall be adjusted (increase / decrease) to / from the Supplier's/Contractor's invoices based on the documentary evidence.

Any increase in GST after the contractual delivery/completion period (*Note 4) shall be to Supplier's/Contractor's account. However, any decrease in the rate of GST shall be passed on to Owner.

For calculating Statutory Variations ceiling amount as declared by the Bidder in price schedule shall only be considered.

2. Basic Custom Duty (BCD) & Social Welfare Surcharge (SWS): If after the due date of submission of last price bid and upto the XX (*Note-3) of contractual delivery/completion period (*Note 4), any increase/decrease occurs in the applicable rate of BCD & SWS on materials imported, the variation in such BCD & SWS shall be to Owner's account and shall be adjusted (increase/decrease) to/from the Supplier's/Contractor's invoices based on the documentary evidence.

Any increase in rate of BCD & SWS on materials imported after the XX (*Note-3) of the contractual delivery/completion period (*Note 4) shall be to Supplier's/Contractor's account. However, any decrease in the rate of BCS & SWS on materials imported shall be passed on to Owner.

For calculating Statutory Variations in BCD/SWS, ceiling amount of CIF Value and rate of custom duty as declared by the Bidder in relevant price schedule shall only be considered.

Note: Indian supplier/contractor to consider input tax credit of IGST and GST Compensation Cess if any (in case of import of raw Materials / components)

in their quoted prices. Hence, Statutory variations on same in case of imported materials from outside India in Supplier's/Contractor's name (i.e., for Indian Bidders) shall be to Supplier/Contractor account.

3. Any new output taxes, duties, cess, levies notified or imposed after the due date of submission of last price bid but upto the contractual date of delivery/completion (*Note 4) shall be to Owner's account. These shall be reimbursed against documentary evidence. However, in case of delay attributable to supplier/contractor, any new output taxes, duties, cess, levies notified or imposed after Time for Completion, defined as above, shall be to supplier's/Contractor's account.

J. TAX INDEMNITY

Any omission/ errors of interpretation of applicability of taxes, duties, cesses and levies, whatsoever named, howsoever named, as are payable to any government, local or statutory authority in India or in any country other than India by the supplier/contractor shall be to supplier's/contractor's account.

If any fine/penalty/any other levy is required to be met by the Owner arising out of any non-compliance/fault/fraud/willful suppression/misstatement of facts/information/documents, whatsoever, of any applicable laws of India or any country other than India by the supplier/contractor/their personnel/sub-contractors/agencies, the same shall be recovered from any amount payable to the supplier/contractor under this contract or under any other contract of the Owner.

If any tax is paid / required to be paid by supplier/contractor in pursuance of any demand of any law enforcement agency/Tax Authority on account of non-compliance/fault/fraud/willful suppression/misstatement of facts/information/documents, whatsoever, of any applicable laws of India or any country other than India by the supplier/contractor/their personnel/sub-contractors/agencies, the same shall be to supplier's/contractor's account only.

GENERAL:

1. *Note-1 : Deleted.
2. *Note-2 : Deleted
3. *Note-3 Time period shall be till the **Contractual Completion/Delivery period**.
4. *Note-4 Contractual delivery/completion period shall include extended contractual delivery/completion period for the reasons attributable to Owner or due to Force Majeure condition.

**ANNEXURE –III TO SPECIAL
CONDITIONS OF CONTRACT**

**TERMS & CONDITIONS FOR SUPERVISION OF
ERECTION, TESTING &
COMMISSIONING/TRAINING AT SITE/HAZOP
STUDY**

**TERMS & CONDITIONS FOR SUPERVISION OF ERECTION, TESTING &
COMMISSIONING/TRAINING AT SITE/HAZOP STUDY**

1. Bidder shall quote per diem charges which shall include lodging, boarding, medical, local transport, all insurances including Bidder's personnel and third party insurance, all other incidental charges and all taxes & duties except GST (for bidders registered in India) which shall be quoted extra and shall be payable against submission of Invoice as per GST rules.
2. Tax(s) as per Government policy shall be deducted at source by Purchaser while making payments against each invoice.
3. **For Foreign Bidders:** To & fro air fare by economy class through most economical route (**Baroda / Ahmedabad / Surat Airport, Gujarat**) and/or AC 2 Tier by Train Fare (*) within India nearest to site, will be reimbursed at actual. Local transportation in bidder's country shall be to bidder's account.
4. **For Indian Bidders:** To & fro air fare within India by economy class through most economical route (**Baroda / Ahmedabad / Surat Airport, Gujarat**) and/or AC 2 Tier by Train Fare(*) nearest to site, will be reimbursed at actual. Indian bidder

(*)In case a bidder travel's by any other mode of transport, the payment shall be made against documentary evidence subject to maximum of AC 2 Tier train fare.
5. Per diem charges shall be payable from the day bidder's person reports at site to Engineer In charge and up to the day he leaves the site after clearance from Engineer In charge. No payment will be made for travel days/period.
6. In case bidder's representative is not called for during Intervening weekly off/Holidays, the same shall be payable at the normal rate of site services. However, in case Seller's representative is called at site during weekly off/Holiday, the same shall be paid @ overtime rate quoted extra by bidder.
7. In case bidder's representative takes leave, per diem charges for that day shall not be payable.
8. Working hours prevailing at site, normally 8 hours/day - Monday through Saturday and holidays as applicable to Purchaser's site personnel shall apply.
9. Selection of Foreign/ Indian supervisory personnel shall be left to Owner's/Purchaser's choice.
10. Supplier's supervisory personnel shall observe/abide by site working conditions prevailing at the existing site, safety codes, Indian laws and local laws.
11. A notice period of 15 days will be given for mobilization of supervisory personnel for supervision of erection.
12. Validity period of per diem rate shall be upto the end of guarantee period. Further, in case services for supervision are required after the guarantee period, 5% annual escalation shall be applicable.
13. Payment: 100% against monthly bills to be submitted by supplier duly certified by the Engineer-in-Charge.
14. **Requirement of Employment Visa for Foreign Nationals**

All foreign nationals coming to India for execution of Projects / Orders will have to apply for Employment Visa only and that grant of Employment Visa would be subject to strict adherence of following norms:

Terms & Conditions for Supervision of Erection, Testing &
Commissioning/Training at Site/Hazop Study

- i) Employment Visa is granted only for the skilled and qualified professional or to a person who is being engaged or appointed by a company, organization, Industry or undertaking etc. in India on contract or employment basis at a senior level, skilled position such as technical expert, senior executive or in managerial position etc.
- ii) Request for employment Visa for jobs for which large number of qualified Indian are available, is not considered.
- iii) Under no circumstances an Employment Visa is granted for routine, ordinary secretarial / clerical jobs.

Bidders are advised in their own interest to check latest Visa rules from Indian Embassy/ High Commission in their country in case foreign nationals are required to be deputed to Indian during execution of the Order.

CHARGES FOR SUPERVISION OF ERECTION / TESTING / COMMISSIONING & PGTR:

S.No.	Description	Supplier's Reply/Information (TO BE QUOTED IN PRICE SCHEDULE) / Currency
1.	Per diem charges (per person) for 8 hours work on normal working days (Monday to Saturday)	TO BE QUOTED IN PRICE SCHEDULE / Day
2.	Overtime rate/hour beyond normal 8 hours work on normal working days.	TO BE QUOTED IN PRICE SCHEDULE / Hour
3.	Overtime rate/hour for work on weekly off days/holidays (as applicable at Project site).	TO BE QUOTED IN PRICE SCHEDULE / Hour

Notes:

1. Quoted per diem rate shall be considered in the evaluation as per RFQ Document.

Bidder's Acceptance:

RFQ No.:
Item:
Offer No.:

Signature with Name & Date and
Seal/Stamp of the Bidder

**ANNEXURE –IV TO SPECIAL
CONDITIONS OF CONTRACT**

TERMS & CONDITIONS FOR SITE WORK

TERMS & CONDITIONS FOR SITE WORK

1. The Supplier shall perform their jobs in eco-friendly manner and in consonance with the objectives of PLL environment management system.
2. The construction / erection work for several other project facilities at various locations within PLL site will be progressing concurrently. It will be the responsibility of Supplier to seek approvals from the Owner for working within & outside the battery limits and also of taking all suitable safety measures as per regulations in force for the safety of the facility.
3. The material shall be collected by the supplier from owner's stores/Project Site/supplier's own stores (as the case may be) and transported to the erection site at supplier's cost and risk.
4. All labour (both skilled and unskilled), tools, tackles and consumables, shall be arranged by supplier at his own cost.
5. Supplier shall arrange for the necessary transport, accommodation, medical, canteen and other facilities for their employees/staff at their own cost and abide by all labour laws, safety codes and statutory regulations and keep Owner indemnified in respect hereof.
6. The Supplier is responsible for keeping his work place neat and clean and shall always avoid scattering of any materials around the work place. The Supplier shall clear the work site of all debris, materials, tools, tackles etc. immediately upon completion of the job. Any temporary Line/cables etc. laid for the purpose of execution of a particular job shall be immediately removed to an agreed location and the site cleared off all such materials.
7. The Supplier shall not throw out gaskets, used electrode pieces, hand gloves, cotton wastes, gunny bags, polythene bags etc. into open channel, any drains or pipe line system. These are to be collected together and deposited in bins/waste collectors earmarked for the purpose of disposal after consultation with Engineer-in-Charge.
8. Construction Power shall be provided by PLL free of cost. The free power shall be provided at designated locations only. Supplier to make all necessary arrangements for taking the power to their required locations.
9. Construction Water shall be provided by PLL free of cost. The water shall be provided at designated locations only. Supplier to make all necessary arrangements for taking the water to their required locations. Drinking water shall be arranged by the supplier at their own cost.
10. Crane, if required shall be in the scope of supplier, unless otherwise specified in Material Requisition.
11. As per the applicable Factory Act the Labour License if required, shall be taken by Supplier before starting the works.

RFQ NO:**SUPPLIER'S SIGNATURE & DATE:****ITEM:****NAME:****OFFER NO:****DESIGNATION:**

ANNEXURE –V
TO
SPECIAL CONDITIONS OF CONTRACT
TERMS & CONDITIONS
FOR
ANNUAL MAINTENANCE CONTRACT (AMC)

ANNUAL MAINTENANCE CONTRACT (AMC)**(TERMS & CONDITIONS)**

1. Bidder shall quote for the Post Warranty Annual Maintenance Contract as per scope defined in Material Requisition / Technical portion for a period of 5 years. Please furnish the year wise Break-up as per the Price Schedule.
2. The AMC Charges quoted in Price Schedule Format shall be inclusive of all the charges for Transportation, Lodging, Boarding, all insurances including third party insurance, all Taxes & Duties and all other incidental charges etc. but excluding GST which shall be payable extra at actual on Submission of Invoice as per GST rules. Owner will not have any liability, whatsoever, over and above the quoted prices.
3. 100% payment shall be paid at the end of each quarter against quarterly progressive bills to be submitted by the Supplier duly certified by authorized representative of Owner.
4. The order for AMC will be placed before the expiry of contractual Warranty Period. The price of AMC services will remain firm & fixed for the complete execution of AMC contract. In case there is delay in start of AMC from the date of expiry of warranty period, the charges shall be paid on pro rata basis for the duration curtailed from original specified AMC period.
5. Seller shall submit 10% of contract value for a PWAMC contract of one year duration.
If the duration of PWAMC contract is for more than one year the contract shall provide CPBG of 10% of one year contract value (maximum of the year wise PWAMC charges).
The validity of CPBG should cover three months beyond total PWAMC contract period.
6. Periodic and Preventive maintenance: Supplier shall depute their engineers to installation site as & when required for regular checkups, as part of periodic maintenance. Supplier shall also depute their service engineers periodically for preventive maintenance, major repairs /replacement and reporting. Price shall also include emergency visits as necessary.
7. Scope of AMC shall be as per MR/Technical portion. The quoted lump sum rate shall include providing all manpower, machineries and materials required to carry out the work as per scope of work of AMC defined in the MR.

**ANNEXURE –VI
TO
SPECIAL CONDITIONS OF CONTRACT
TERMS & CONDITIONS FOR TRAINING
AT SUPPLIER/OEM WORKS**

TERMS & CONDITIONS FOR TRAINING

1. Bidder shall quote Training charges of Owner's Operation and Maintenance personnel at Bidder's works/training facility on lumpsum basis (as per scope defined in the Material Requisition).
2. All expenses including but not limited to Air-fare, accommodation, local conveyance, living expenses etc. of Owner's personnel shall be borne by Purchaser.
3. Quoted prices shall be inclusive of all taxes & duties except GST which shall be payable extra at actuals against submission of documents as per GST rules.
4. A notice period of 15 days will be given by EIL/Owner for prior arrangement.
5. PAYMENT TERMS: Shall be as per Bid Data Sheet (BDS).

A. LUMPSUM CHARGES:

Sno	Description	RATE IN CURRENCY
1	Lumpsum charges	Quoted in Price Schedule

FORM OF ADVANCE BANK GUARANTEE
(ON NON-JUDICIAL PAPER OF APPROPRIATE VALUE)

To,

Petronet LNG Limited

4th Floor, Tower-I, World Trade Center

Nauroji Nagar

New Delhi – 110029

Subject: Bank Guarantee No. _____ dated:

WHEREAS, _____ (Contractor / Vendor/ Supplier Name) a company incorporated under _____ (Act) having its registered office at _____ (hereinafter referred to as the “Contractor”/ “Vendor”/ “Supplier” which expression shall unless repugnant to the context or meaning thereof include its successors and permitted assigns) has been issued _____ (LOA/order No.), by M/s Petronet LNG Limited having its registered office at 4th Floor, Tower -I, World Trade Center, Nauroji Nagar, New Delhi - 110 029 (hereinafter referred to as the “Owner” which expression shall unless repugnant to the context or meaning thereof include its successors and assigns) for carrying out / supplying _____ (subject), for Owner, and further the parties shall enter into an agreement to execute the scope of work under this LOA/Purchase Order (such agreement shall hereinafter be referred as “Contract”).

WHEREAS as per the _____ (Contract/LOA No/ Purchase Order.) the Contractor/Supplier is obliged to furnish to the PLL an irrevocable, unconditional, payable on first demand, bank guarantee issued by specified financial institutions acceptable to the PLL, as mentioned in the said Contract/LOA No. for the advance claimed by the Contractor / Supplier of the Contract.

AND WHEREAS the Bank (as defined herein below) has affirmed that it is one of the scheduled bank and at the request of the Contractor and for sufficient consideration, the Bank has agreed to issue this advance bank guarantee in favor of the PLL.

AND WHEREAS _____ (Bank Name) having its registered office at _____ and a branch office at _____ (insert name of city in India) India, hereinafter referred to as the “Bank” (which expression shall unless repugnant to the context or meaning thereof be deemed to mean and include its successors), being Acceptable Bank (*refer Sl No. 2 of Instructions for furnishing Bank Guarantee for Criteria of acceptable bank*), has at the request of the Contractor / supplier / Surety agreed to issue this advance bank guarantee in favour of the PLL.

NOW THEREFORE, the Bank hereby undertakes the pecuniary responsibility of the Contractor to the PLL for the due performance of the Contract and for the payment of any money by the Contractor / supplier to the PLL and hereby issues in favour of the PLL this on demand, irrevocable and unconditional and payment bank guarantee (hereinafter referred to as the “Guarantee”) on behalf of the Contractor / supplier in the amount of Indian Rupees _____ [*amount claimed for advance for procurement and 110% of advance amount claimed for works , service , consulting contracts*].

The Bank for the purpose hereof unconditionally and irrevocably undertakes to pay to the PLL without any demur, reservation, cavil, protest or recourse; immediately on receipt of first written demand from the PLL, any sum or sums (by way of one or more claims) not exceeding in the aggregate the amount of Indian Rupees _____ (insert an amount) without the PLL requiring to furnish proof or to show / justify to the Bank any ground(s) or reason(s) for such demand for the sum specified therein and notwithstanding any dispute or difference between the PLL and the Contractor in respect of the performance of the Contract or moneys payable by Contractor to the PLL or any matter whatsoever related thereto.

The Bank acknowledges that any such demand by the PLL of the amounts payable by the Bank to the PLL shall be final, binding and conclusive evidence in respect of the amounts payable by the Contractor / supplier to the PLL.

The Bank hereby waives the necessity for the PLL from demanding the aforesaid amount or any part thereof from the Contractor / supplier before enforcement of this Guarantee and also waives any right that the Bank may have of first requiring the PLL to pursue its legal remedies against the Contractor / supplier, before presenting any written demand to the Bank before enforcement / making payment under this Guarantee.

The Bank's obligations under this Guarantee shall not be reduced by reason of any partial performance of the Contract. The Bank's obligations shall not be reduced by any failure by PLL to timely pay or perform any of its obligation(s) under the Contract.

Any payment made hereunder shall be made free and clear of and without deduction for, or on account of, any present or future taxes, levies, imposts, duties, charges, fees, commissions, deductions or withholdings of any nature whatsoever provided always nothing herein contained will enlarge our liability hereunder beyond the limit of _____ (*amount claimed for advance for procurement and 110% of advance amount claimed for works service , consulting contracts*)

This Guarantee shall be a continuing bank guarantee until its expiry, i.e. _____ and shall not be discharged by the change in constitution of any member of the Contractor and the Guarantee shall not be affected or discharged by the liquidation, winding up, bankruptcy, re organization, dissolution or insolvency of any member of the Contractor or any other circumstances whatsoever.

This Guarantee shall be in addition to and not in substitution or in derogation of any other security held by the PLL to secure the performance of the obligations of the Contractor under the Contract. The Bank agrees that the PLL at its option shall be entitled to enforce this Guarantee against the surety, as a principal debtor in the first instance without proceeding at the first instance against the Contractor / Contractor.

Without prejudice to any continuing liability to perform obligations under this Guarantee which have arisen prior thereto, the Bank shall be released from any further obligations arising hereunder after _____.

This Guarantee shall not be assigned or transferred by the Bank.

This Guarantee is subject to the laws of India. Any suit, action, or other proceeding arising out of this Guarantee or the subject matter hereof shall be subject to the exclusive jurisdiction of courts of New Delhi, India. This guarantee is to be returned to the Bank immediately on expiry of the claim period. If the Bank does not receive the bank guarantee latest by the expiry of the claim period, it shall be deemed to be automatically cancelled.

The Bank has the power to issue this Guarantee in favour of the PLL. The aggregate liability of the Bank under this Guarantee shall not under any circumstance exceed Indian Rupees _____ (insert an amount)

In witness whereof the Bank, through its authorized officer, has set its hand and stamp on this _____ day of _____

Notwithstanding anything contained hereinabove:

I. Our liability under the bank guarantee shall not exceed Rs. _____

II. The bank guarantee shall be valid upto _____ (30 days plus Contractual delivery date / 30 days plus Contractual Completion date.)

III. The beneficiary's right as well the Bank's liability under this guarantee shall stand extinguished unless a written claim or demand is made under this Guarantee on or before ___ (6 months after ABG expiry date) .

(Signature)

Name

Designation with Stamp

Duly authorized representative

Vide power of attorney No. _____

Dated _____

Witness

(On stamp paper of requisite value)

INSTRUCTIONS FOR FURNISHING BANK GUARANTEE

1. Bank Guarantee by Indian Bidders will be given on non-judicial stamp paper as per stamp duty applicable in State of New Delhi. The non-judicial stamp paper should be in name of the issuing bank.
2. **The Advance Bank Guarantee shall be accepted only when issued from a bank fulfilling the criteria of the "Acceptable Bank" as mentioned in Bid Data Sheet (BDS).**
3. The validity of Advance Bank Guarantee shall be 30 days plus Contractual delivery date / 30 days plus Contractual Completion date.
4. Claim Period shall be 06 months beyond BG expiry date.

Request Letter: Transmission of Bank Guarantee Cover Message <to be submitted by Bidder to BG issuing bank>

Date: _____

The Manager,
(Bank),
(Branch)

Sub: Inclusion of unique identifier while transmitting BG cover messages where beneficiary bank is ICICI Bank India

Dear Sir/Ma'am,

I/We, _____, request you to include unique identifier **PLNG574440489 in field 7037** of the SFMS cover messages IFN COV 760 (for BG issuance) and IFN COV 767 (for BG amendment) while transmitting the same to the beneficiary bank (ICICI Bank, IFSC: ICIC00000007). This is required by Petronet LNG Limited as per their tender/contract requirement.

Thanking You, _____

The Template for MT 760-COV (SFMS) for issuing bank is mentioned below:

```
{
:7020:
:7022:
:7024:ADVANCE
:7025:INRxxxxx
:7026:
:7027:<Date of Issue>
:7029:<Expiry date>
:7030:<Place of Claim Lodgement>
:7031:<Issuing Bank IFSC>
:7032:<Issuing Bank Name>
:7033:<Applicant Name>
:7034:PETRONET LNG LIMITED <Address>
:7035:ICIC0000007
:7036:ICICI BANK LIMITED
::7037:PLNG574440489
-}
```

PERFORMANCE BANK GUARANTEE
(ON NON-JUDICIAL PAPER OF APPROPRIATE VALUE)

To,
Petronet LNG Limited
4th Floor, Tower-I, World Trade Center
Nauroji Nagar
New Delhi – 110029

Subject : Bank Guarantee No. _____

WHEREAS, _____ (*Contractor / Vendor/ Supplier Name*) a company incorporated under _____ having its registered office at _____ (hereinafter referred to as the “*Contractor*”/ “*Vendor*”/ “*Supplier*” which expression shall unless repugnant to the context or meaning thereof include its successors and permitted assigns) has been issued _____, by M/s Petronet LNG Limited having its registered office at 4th Floor, Tower -I, World Trade Center, Nauroji Nagar, New Delhi - 110 029 (hereinafter referred to as the “*Owner*” which expression shall unless repugnant to the context or meaning thereof include its successors and assigns) for carrying out _____, for Owner, and further the parties shall enter into an agreement to execute the scope of work under this LOA (such agreement shall hereinafter be referred as “*Contract*”).

WHEREAS as per _____ (*Contract/LOA No/ Purchase Order No.*) the Contractor / Supplier is obliged to furnish to the Owner an irrevocable, unconditional, first demand bank guarantee issued by specified financial institutions acceptable to the Owner, for a sum equal to 10% (ten percent) of the Contract Price for the due performance by the Contractor / Supplier of the Contract/ PO.

AND WHEREAS the Bank (as defined herein below) has affirmed that it is one of the scheduled bank and at the request of the Contractor and for sufficient consideration, the Bank has agreed to issue this performance bank guarantee in favor of the Owner.

AND WHEREAS _____ (*Bank Name*) having its head office at _____ and Branch office at _____ (insert name of city in India) India, hereinafter referred to as the “*Bank*” (which expression shall unless repugnant to the context or meaning thereof be deemed to mean and include its successors), being acceptable Bank (*refer Sl No. 2 of Instructions for furnishing Bank Guarantee for Criteria of Acceptable bank mentioned below*), has at the request of the Contractor / supplier / Surety agreed to issue this performance bank guarantee in favour of the Owner.

NOW THEREFORE, the Bank hereby undertakes the pecuniary responsibility of the Contractor to the Owner for the due performance of the Contract and for the payment of any money by the Contractor/ Supplier to the Owner and hereby issues in favour of the Owner this on demand, irrevocable and unconditional performance and payment bank guarantee (hereinafter referred to as the “*Guarantee*”) on behalf of the Contractor / supplier in the amount of Indian Rupees _____ (*insert an amount equal to ten percent (10%) of the Contract Price/ estimated Contract Price*).

The Bank for the purpose hereof unconditionally and irrevocably undertakes to pay to the Owner without any demur, reservation, cavil, protest or recourse; immediately on receipt of first written demand from the Owner, any sum or sums (by way of one or more claims) not exceeding in the aggregate the amount of Indian Rupees _____ (*insert an amount equal to ten percent (10%) of the Contract Price/ estimated Contract Price*) without the Owner requiring to furnish proof or to show / justify to the Bank any ground(s) or reason(s) for such demand for the sum specified therein and notwithstanding any dispute or difference between the Owner and the Contractor in respect of the performance of the Contract or moneys payable by Contractor to the Owner or any matter whatsoever related thereto.

The Bank acknowledges that any such demand by the Owner of the amounts payable by the Bank to the Owner shall be final, binding and conclusive evidence in respect of the amounts payable by the Contractor / supplier to the Owner.

The Bank hereby waives the necessity for the PLL from demanding the aforesaid amount or any part thereof from the Contractor / supplier before enforcement of this Guarantee and also waives any right that the Bank may have of first requiring the PLL to pursue its legal remedies against the Contractor / supplier, before presenting any written demand to the Bank before enforcement / making payment under this Guarantee.

The Bank further unconditionally agrees with the Owner that the Owner shall be at liberty, without the Bank's consent and without affecting in any manner the Bank's obligation under this Guarantee, from time to time, to:

- (i) vary and/or modify any of the terms and conditions of the LOA/Contract,
- (ii) extend and/or postpone the time for performance of the obligations of the Contractor under the LOA/Contract, or
- (iii) forbear or enforce any of the rights exercisable by the Owner against the Contractor under the terms and conditions of the Contract

and the Bank shall not be relieved from its liability by reason of any such act or omission on the part of the Owner or any indulgence by the Owner to the Contractor or other thing whatsoever which under the law relating to sureties would, but for this provision, have the effect of relieving the Bank of its obligations under this Guarantee.

The Bank's obligations under this Guarantee shall not be reduced by reason of any partial performance of the Contract. The Bank's obligations shall not be reduced by any failure by Owner to timely pay or perform any of its obligations under the Contract.

Any payment made hereunder shall be made free and clear of and without deduction for, or on account of, any present or future taxes, levies, imposts, duties, charges, fees, commissions, deductions or withholdings of any nature whatsoever and by whomever imposed; and where any withholding on a payment is required by law, the Bank shall comply with such withholding obligations and shall pay such additional amount in respect of such payment such that Owner receives the full amount due hereunder as if no such withholding had occurred.

This Guarantee shall be a continuing bank guarantee until its expiry, i.e. _____ and shall not be discharged by the change in constitution of any member of the Contractor and the Guarantee shall not be affected or discharged by the liquidation, winding up, bankruptcy, reorganization, dissolution or insolvency of any member of the Contractor or any other circumstances whatsoever.

This Guarantee shall be in addition to and not in substitution or in derogation of any other security held by the Owner to secure the performance of the obligations of the Contractor under the Contract.

The Bank agrees that the Owner at its option shall be entitled to enforce this Guarantee against the surety, as a principal debtor in the first instance without proceeding at the first instance against the Contractor.

Without prejudice to any continuing liability to perform obligations under this Guarantee which have arisen prior thereto, the Bank shall be released from any further obligations arising hereunder after _____ (validity of the guarantee)

This Guarantee shall not be assigned or transferred by the Bank.

This Guarantee is subject to the laws of India. Any suit, action, or other proceeding arising out of this Guarantee or the subject matter hereof shall be subject to the exclusive jurisdiction of courts of New Delhi, India.

The Bank has the power to issue this Guarantee in favour of the Owner. The aggregate liability of the Bank under this Guarantee shall not under any circumstance exceed Indian Rupees _____ (*insert an amount equal to ten percent (10%) of the Contract Price/ estimated Contract Price*).

Capitalised terms not otherwise defined herein shall have their respective meanings given such terms set forth in the Contract.

In witness whereof the Bank, through its authorised officer, has set its hand and stamp on this _____ day of _____

Notwithstanding anything contained hereinabove:

I. Our liability under the bank guarantee shall not exceed Rs. _____

II. The bank guarantee shall be valid upto _____

III. The beneficiary's right as well the Bank's liability under this guarantee shall stand extinguished unless a written claim or demand is made under this Guarantee on or before ___ (6 months after BG expiry date) .

(Signature)

Name _____

Designation with Stamp

Duly authorised representative

Vide power of attorney No. _____

Dated _____

Witness.

INSTRUCTIONS FOR FURNISHING BANK GUARANTEE

1. Bank Guarantee by Indian Bidders will be given on non-judicial stamp paper as per stamp duty applicable in State of New Delhi. The non-judicial stamp paper should be in name of the issuing bank.
1. **The Performance Bank Guarantee shall be accepted only when issued from a bank fulfilling the criteria of the "Acceptable Bank" as mentioned in Bid Data Sheet (BDS).**
2. The expiry date should be arrived at by adding 90 days to the Contract completion / Delivery date plus warrantee/guarantee/defect liability period (if any) as specified in the bidding documents.
3. Claim Period shall be 06 months beyond BG expiry date.

Request Letter: Transmission of Bank Guarantee Cover Message <to be submitted by Bidder to BG issuing bank>

Date: _____

The Manager,
(Bank),
(Branch)

Sub: Inclusion of unique identifier while transmitting BG cover messages where beneficiary bank is ICICI Bank India

Dear Sir/Ma'am,

I/We, _____, request you to include unique identifier PLNG574440489 in field 7037 of the SFMS cover messages IFN COV 760 (for BG issuance) and IFN COV 767 (for BG amendment) while transmitting the same to the beneficiary bank (ICICI Bank, IFSC: ICIC00000007). This is required by Petronet LNG Limited as per their tender/contract requirement.

Thanking You,

The Template for MT 760-COV (SFMS) for issuing bank is mentioned below:

```
{
:7020:
:7022:
:7024:PERFORMANCE
:7025:INRxxxxxx
:7026:
:7027:<Date of Issue>
:7029:<Expiry date>
:7030:<Place of Claim Lodgement>
:7031:<Issuing Bank IFSC>
:7032:<Issuing Bank Name>
:7033:<Applicant Name>
:7034:PETRONET LNG LIMITED <Address>
:7035:ICIC0000007
:7036:ICICI BANK LIMITED
:7037:PLNG574440489
-}
```

PROFORMA OF SURETY BOND FOR CONTRACT PERFORMANCE SECURITY

(To be executed on non-judicial stamp paper of appropriate value)

Ref.....

Guarantee No.....

To,

Petronet LNG Limited

4th Floor, Tower-I, World Trade Center
Nauroji Nagar
New Delhi – 110029

Dear Sir (s),

In consideration of you, Petronet LNG Limited a Company duly incorporated and executing under the laws of India having its office at 04th , 05th and 06th Floor, Tower -I, World Trade Center, Nauroji Nagar, New Delhi - 110 029 (hereinafter referred to as the “**PLL**”, which expression shall unless it be repugnant to the subject or context thereof include its successors and assigns) having awarded the Contract to **[insert name of the Contractor]** having its registered office at **[insert address of the Contractor]** (hereinafter referred to as the “**Contractor**”, which expression shall unless it be repugnant to the subject or context thereof include its/their executors, administrators, successors and assigns) in relation to **[insert Contract Name/Work Description]** pursuant to the Contract Agreement bearing Reference Number **[insert reference number]** (hereinafter collectively referred to as "**Contract Documents**"), we **[insert name of the Insurer]** having our registered office at **[insert registered address of the Guarantor]** and one of its branch at **[insert relevant branch address of the Insurer]**, at the request of the Contractor, do hereby irrevocably, unconditionally, and without reservation guarantee the due and faithful performance, discharge and compliance of all the terms, conditions, and obligations under the Contract Documents by the said Contractor and unconditionally undertake to pay to PLL forthwith on first demand without any demur, reservation, recourse, contest, protest, or requiring proof of satisfaction or condition, and without reference to the Contractor, an amount of **INR _____ (Rupees _____ only)[insert Guarantee Amount]** (hereinafter referred to as the "**Guaranteed Amount**") as our primary obligation under this Insurance Bond. Any such demand made by PLL on the insurer shall be conclusive, binding and notwithstanding any difference between PLL and the Contractor or any dispute pending before any court, tribunal or any other authority. .

NOW, THEREFORE, the Insurer hereby unconditionally and irrevocably guarantees and affirms as follows:

1. This Insurance Bond (“**Performance Guarantee**”) shall be a continuing guarantee and shall remain in full force and effect till all claims or demands made by the PLL on the Insurer (“**Guarantor**”) are realised and/or until the PLL discharges this Bond, subject however that the PLL shall have no claims under this Guarantee after **[insert time and date including at least 03 (three) months beyond the defect liability period, plus six months’ claim period]** or any written extension(s) thereof.
2. In order to give full effect to this Bond, PLL shall be entitled to treat the Insurer (“**Guarantor**”) as the Principal Debtor. PLL shall have the fullest liberty without affecting in any way the liability of the Insurer under this Bond / Guarantee from time to time or to vary any of the terms and conditions contained in the said Contract Documents or to extend time for performance of the

Contract or the validity period of the Performance Guarantee or the period for compliance with any obligations by the Contractor or to postpone for any time and from time to time any of the powers exercisable by PLL against the said Contractor and either to enforce or forbear from enforcing any of the terms and conditions contained in the said Contract Documents or the securities available to PLL, and the Guarantor shall not be released from its liability under these presents by any exercise by PLL of the liberty with reference to the matters aforesaid or by reason of time being given to the said Contractor or any other forbearance, act or omission on the part of PLL or any indulgence by PLL to the said Contractor or by any change in the constitution of PLL or its absorption, merger or amalgamation with any other person or any other matter or thing, whatsoever, which under the law relating to Guarantee would but for this provision have the effect of releasing the Guarantor from its such liability.

3. It shall not be necessary for the PLL to proceed against the Contractor before proceeding against the Guarantor and the Guarantee herein contained shall be enforceable against the Insurer / Guarantor as the Principal Debtor notwithstanding the existence of any other undertaking or security for any indebtedness of the Contractor to the PLL and notwithstanding that any such security shall at the time when claim is made against the Guarantor or proceedings taken against the Guarantor hereunder, be outstanding or unrealized.
4. The amount stated by the PLL in any demand, claim or notice if made with reference to this Insurance Bond shall as between the Guarantor and the PLL which shall be final, conclusive and binding with regard to the amount payable by the Guarantor to the PLL hereunder.
5. The liability of the Insurer / Guarantor to PLL under this Guarantee shall remain in full force and effect notwithstanding the existence of any difference or dispute between the Contractor and the PLL, the Contractor and the Guarantor and/or the Guarantor and the PLL or otherwise, howsoever, related to this Insurance Bond or Guarantee or the liability of the Contractor to the PLL, and notwithstanding the existence of any instructions or purported instructions by the Contractor or any other person to the Guarantor not to pay or for any cause withhold or defer payment to the PLL under this Insurance bond / Guarantee, with the intent that notwithstanding the existing of such difference, dispute or instructions, the Guarantor shall be and remain liable to make payment to the PLL in terms thereof.
6. We, the Guarantor, further agree that PLL shall be the sole judge to decide as to whether the Contractor is in default of due and faithful fulfilment and compliance with the terms and conditions contained in the aforesaid Contract Documents and the decision of PLL that the Contractor is in default as aforesaid shall be final and binding on us, notwithstanding any differences between PLL and the Contractor or any dispute pending before any Court, Tribunal, Arbitrator or any other authority.
7. This Guarantee shall not be determined or affected by the liquidation or winding up or dissolution or change of constitution or insolvency of the Contractor or any change in the legal constitution of the Insurer / Guarantor or the PLL.
8. Any notice by way of request, demand or otherwise hereunder shall be sufficiently given or made if addressed to the Insurer / Guarantor and sent via email or by courier or by registered post, to the Insurer / Guarantor at the address set forth herein.
9. We undertake to make the payment on receipt of your notice of claim on us addressed to name of Guarantor along with branch address and delivered at our above branch and/or via email to: **[insert email ID]** which shall be deemed to have been duly authorized to receive the said notice of claim.

10. The Insurer's obligations under this Bond / Guarantee shall not be reduced by reason of any partial performance of the Contract by the Contractor. The Insurer's obligations under this Bond shall not be reduced by any failure by PLL to timely pay or perform any of its obligations under the Contract.
11. We, the Insurer / Guarantor, further undertake not to revoke this Guarantee during its currency except with the previous express consent of PLL in writing.
12. The Insurer / Guarantor declares that it has power to issue this Guarantee and discharge the obligations contemplated herein, the undersigned is duly authorised and has full power to execute this Guarantee for and on behalf of the Contractor.
13. This Guarantee issued by us is in full compliance with applicable laws of India, as amended from time to time.
14. This Insurance Bond / Guarantee is for the benefit of PLL and its successors and assigns. This Bond/Guarantee is binding not only on the Guarantor, but also on the Guarantor's successors and permitted assigns. The Guarantor shall not assign its rights and obligations hereunder to any person, insurer, company or other entity unless permitted by PLL in writing.
15. Notwithstanding anything herein:
 - 1 The Insurer's / Guarantor's liability under this Guarantee shall not exceed Rs. **[insert Guarantee Amount]**;
 - 2 This Bond / Guarantee shall remain in force until **[insert]**;
 - 3 This Bond/ Guarantee shall have additional claim period of **[six]** months thereafter; and
 - 4 The Insurer / Guarantor is liable to pay the Guaranteed amount or any part thereof under this Bond / Guarantee only if PLL serves upon the Guarantor a written claim or demand upon the Guarantor or any branch thereof on or before the aforesaid claim period.

Signed and sealed this [●] day of [●], [●] at [●].

SIGNED, SEALED, AND DELIVERED

For and on behalf of the Guarantor by:

(Signature)

(Name)

(Designation)

(Code Number)

(Address)

-----o-----o-----o-----o-----

Instructions: -

- a) The surety bond shall be from a Surety Insurer as per guidelines issued by Insurance Regulatory and Development Authority of India (IRDAI) as amended from time to time.
- b) The surety bond should contain the name, designation and code number of the officer(s) signing the surety bond.
- c) The address, telephone number, E-mail and other details of the head office of the surety insurer as well as of issuing branch should be mentioned on the covering letter of issuing branch. The letter may also include any web portal link, from where the Surety Bond can be confirmed by the Company.
- d) The Insurance Surety Bond should be on Non-Judicial stamp paper/e-stamp paper of appropriate value as per Stamp Act prevailing in the state(s) where the Insurance Surety Bond is submitted or is to be acted upon or the rate prevailing in State where the Insurance Surety Bond is executed, whichever is higher. The Stamp Paper/e-stamp paper shall be purchased in the name of Bidder/Insurer issuing the Insurance Surety Bond.



युनाइटेड इंडिया इंश्युरेन्स कंपनी लिमिटेड
United India Insurance Co. Ltd.



(D-24 & E-25, 2nd Floor, Himalaya House, 23, K.G.Marg, New Delhi-110001, India)

MARINE CUM ERECTION INSURANCE POLICY

**POLICY NO.: 5003004425P113683258 (SCE) /
5003002125P113683259 (MCE)
UIN NO. IRDAN545CP0066V01200708**

**PERIOD OF INSURANCE
From 00:00 Hrs of
01/11/2025 To Midnight of
31/03/2028**

Insured
M/s PETRONET LNG LIMITED



4TH FLOOR, TOWER I, WORLD TRADE CENTER, NAUROJI NAGAR, NEW DELHI - 110 029,
INDIA
110029
SOUTH WEST DELHI, DELHI

**Issuing Office Address:
Corporate Cell, Delhi
D-24 & E-25, 2nd Floor, Himalaya House
23, K.G. Marg, New Delhi- 110001, India**

1. Policy Schedule

Policy No.	5003004425P113683258 (SCE) / 5003002125P113683259 (MCE)
Policy Type	MARINE CUM ERECTION INSURANCE POLICY
The Insurer	United India Insurance Company Limited Corporate Cell, Delhi D-24 & E-25, 2 nd Floor, Himalaya House 23, K.G. Marg, New Delhi- 110001, India
Policy Period	00:00 Hrs of 01/11/2025 to Midnight of 31/03/2028 <i>including 4 months of testing (including hot testing) and commissioning plus 24 months of Maintenance.</i>
Unique Reference Code	UII500300EN0123579642526
Co- Insurance Details	<ol style="list-style-type: none"> 1. United India Insurance Co. Ltd., LCB, New Delhi: 50% share 2. ICICI Lombard General Insurance Co. Ltd.: 19% share 3. Bajaj General Insurance Limited: 16.41% share 4. National Insurance Co. Ltd.: 14.59% share
Name of Project	750 KTPA Propane De-Hydrogenation Unit (PDH), 500 KTPA Polypropylene unit (PP) and Ethane & Propane import, storage and transfer facilities at Dahej, in the state of Gujarat, India. ("Project")
Name of Insured	<ol style="list-style-type: none"> i. Petronet LNG Limited and / or Subsidiaries thereof and / or Joint Ventures / Consortiums including the aforementioned as Principal/Main Contractors. ii. Principals and/or Project Financers and/or Lenders. Lenders are State Bank of India, Bank of Baroda, ICIC Bank and Axis Bank along With SBI CAPS as Security Trustee. iii. President of India iv. Licensors and Project management Consultants for the Project. Project Management Consultant is Engineers India Limited. Licensors are M/s UOP LLC for PDH Unit and M/s Lummus Novolen Technology GMBH for PP Unit v. (a) Other Contractors and/or Sub-contractors of any tier. (b) Architects and/or Consultants and/or Design Bureaux and/or Suppliers and/or their Subsidiaries thereof and / or Joint Ventures / Consortiums (not forming part of i) above, as regards their on-site activities but excluding their design, plan or specification work. but only to the extent that the Insured mentioned in (i) above has, by contract or agreement, agreed to provide such party(ies) with the benefit of this insurance (or part thereof). vi. Any other party having an insurable interest (and not mentioned above) to the extent that the Insured



	mentioned in (i) above is required by contract or agreement to provide insurance to such party(ies).										
Mailing Address	4TH FLOOR, TOWER I, WORLD TRADE CENTER, NAUROJI NAGAR, NEW DELHI - 110 029, INDIA										
Location/s of The Risk	<p>The proposed Petrochemical complex will be set up at 47.73 hectares of Greenfield land located adjacent to the existing Dahej LNG complex of Petronet LNG Limited (PLL) at GIDC Industrial Estate, Plot No 7 A, Dahej, Taluka Vagra, Distt, Bharuch, Gujarat, Bharuch, 392130 and coming under Gujarat Industrial Development Corporation (GIDC). Geographical Location is given in Toposheet no. F43M5-46 C5, F43M6-46 C6, F43M9-46 C9 & F43M10-46 C10 of Survey of India (Sol) Map.</p> <p>Detail of Co-ordinates (lat-long) of all four corners of the proposed project site:</p> <table border="1"> <thead> <tr> <th>Latitude</th> <th>Longitude</th> </tr> </thead> <tbody> <tr> <td>21°40'12.84"N</td> <td>72°32'21.78"E</td> </tr> <tr> <td>21°39'55.47"N</td> <td>72°32'22.51"E</td> </tr> <tr> <td>21°40'15.79"N</td> <td>72°32'46.20"E</td> </tr> <tr> <td>21°39'58.90"N</td> <td>72°32'50.82"E</td> </tr> </tbody> </table>	Latitude	Longitude	21°40'12.84"N	72°32'21.78"E	21°39'55.47"N	72°32'22.51"E	21°40'15.79"N	72°32'46.20"E	21°39'58.90"N	72°32'50.82"E
Latitude	Longitude										
21°40'12.84"N	72°32'21.78"E										
21°39'55.47"N	72°32'22.51"E										
21°40'15.79"N	72°32'46.20"E										
21°39'58.90"N	72°32'50.82"E										
Nature of Project	All works related to but not limited to 750 KTPA Propane De-Hydrogenation Unit (PDH), 500 KTPA Polypropylene unit (PP) and Ethane & Propane import, storage and transfer facilities at Dahej, in the state of Gujarat, India.										
Insured Property	All materials, equipment, supplies, Plant & Machinery, goods, consumables, any free issue materials, spare parts and materials in transit forming part or intending to form part of the Project, whether located on-site or at off-site storage, fabrication yards, vendor/manufacturer premises or in transit, including but not limited to temporary works / structures, temporary civil works including project office buildings, site facilities, site roads, lighting , fencing, construction power, enabling works and amenities, common facilities, improvements, tie-ins, connections and additions/modifications to existing facilities, pipelines, storage sheds, tanks, spheres, fabrication/storage yard including all equipment, power Infra, Security, IT infrastructure, instrumentation, automation and control systems, material awaiting erection or installation and all other property collectively forming part of or intended to form part of the Project.										

2. Sum Insured

A. Marine Open Cover:

Description	Amount in INR(incl. taxes)
Imported Supplies	2,868 Cr
Indigenous Supplies	7,261 Cr
Total Sum Insured	10,129 Cr

Per Bottom Limit: INR 250 Crore



B. **Section-I- Construction/Erection All Cover:** INR 18,582 Cr
Section-II- Third Party Liabilities Cover: INR 25 Crore for any one accident and INR 50 Crore in aggregate.

3. DEDUCTIBLES

A.	Marine Open Cover Excess:	0.25% of the consignment value subject to minimum of INR 1,00,000/-for each and every claim.
B.	Section – I - Erection “All Risks” Excess:	<ul style="list-style-type: none"> • Excess for AOG – 10 % of the claim amount subject to a minimum of INR 5 Crore (i.e. Acts of God perils like storm, tempest, flood, water damage, subsidence, collapse and earthquake). • For Testing & Commissioning Claims including Fire and Explosion during Testing and Commissioning Period/ Fire & Explosion/ Maintenance / Design Defect - 10% of claim amount subject to minimum of INR 5 Crore for each and every loss. • All other Perils - 5% of claim amount subject to minimum of INR 2.5 Crore for each and every loss.
	Section – II -Third Party Liability Excess:	Death/ Bodily Injury - Nil. Property loss/damage – 5% of claim subject to minimum of INR 10 lacs for eel.

4. PREMIUM



5. INSTALLMENT SCHEDULE

6. A: MARINE OPEN COVER

Marine cargo insurance for all Goods, Plant & Machinery, Equipment, Materials, Consumables and free-issue materials etc. intended to form part of the Project, including items sent back and forth for repair/rectification/fabrication/testing, in transit from anywhere in the world to anywhere in the world, on a 'warehouse to warehouse' basis against loss or damage arising from customary 'all-risks' perils (including war, strikes, riot and civil commotion) while in transit by any conveyances and/or vessels and/or air and/or barge and/or road and/or rail and/or any other conveyance by land, sea or air and connections, including during loading, unloading and temporary storage, up to full replacement value of such Goods, Plant & Machinery, Equipment, Materials, Consumables and free-issue materials etc.

Coverage shall also include the movement of damaged Plant & Machinery and Equipment etc. sent back and forth for repair/rectification/fabrication/testing (from project site/fabrication yard to vendor's site and back to project site/fabrication yard).

Coverage shall further include the movement of project Goods/Materials/Plant & Machinery etc. from fabrication/storage yard to project site and vice versa.

Basis of Valuation:

1. **For Imported Supplies:** Costs, insurance, freight charges, loading and unloading charges, survey charges, duties and taxes (including Customs Duties) plus 10%, plus anticipated future escalation of 20%.
2. **For Indigenous Supplies:** Costs, insurance, freight charges, loading and unloading charges, survey charges, duties and taxes (including GST) plus 10%, plus anticipated future escalation of 20%.
3. **Second-hand and used items:** Market value for a similar item in equivalent condition immediately prior to transit + GST (at actual).
4. **Return:** Invoice Value + 10%.
5. **Machineries moving to and from for repairs:** Invoice Value + Cost of Repairs including GST.



All valuations above shall be deemed to represent the replacement cost as new, unless otherwise stated (e.g., used equipment), and shall include all costs reasonably incurred for procurement, transportation, insurance, customs clearance, duties, taxes, surveys, and preparation for installation.

Subject Matter Insured:

Cargo and/or merchandise of every description incidental to the Insured's business and the Project and/or any other cargo where the Insured has insurable interest, consisting principally of, but not limited to:

- All Goods, Plant & Machinery, Equipment, Materials, Consumables, Stores and Spares to be installed as part of the Project, whether new or used
- All capital equipment, machinery (including over-dimensional cargo, cranes, engines, pumps, electronic/electrical/mechanical equipment's and spares), laboratory equipment and its spares, fragile and non-fragile goods (including glass, insulation, refractory items), structural materials, mild steel plates, control and remote operated valves, pipes, fittings, hardware and building materials (cement, packing materials, wrapping/coating materials)
- Bulk and break-bulk cargo, free samples, raw materials, hazardous and non-hazardous chemicals, catalysts (including spent catalysts), adhesives, temperature-sensitive cargo;
- Containers of any kind, materials procured on loan, goods held in trust or under custody/control of the Insured;
- Goods removed for repair, rectification, fabrication, testing, renovation or job work and returning to the project site;
- Goods/materials moving between storage/fabrication yards, vendor premises, ports, warehouses and the Project site;
- All other goods for which the Insured is required to insure, or authorized/instructed to insure, or which may otherwise be at their risk and/or for which they may be legally liable, or which are incidental to the performance of the Project.

The above shall include all such goods in transit by any mode (road, rail, sea, air, barge, inland waterways) from anywhere in the world to anywhere in the world on a warehouse-to-warehouse basis, including loading, unloading, transshipment, temporary storage and associated handling risks.

Storage Period:

The cover shall include the risk of loading, unloading and handling during transit at all points and temporary storage during the ordinary course of transit at all locations. The risk of storage during transit is held covered in accordance with the Duration Clause of ICC A/ ITC A/ ICC(Air), but extended to allow up to 60 days additional storage beyond the standard duration, automatically, without prior declaration or additional premium.

Any intentional storage/ or storage beyond this period of 60 days after expiry of the respective ICC(A)/ITC (A)/ICC(Air) duration periods, shall be held covered subject to prior notice to insurers and agreement on additional terms and conditions if applicable.

For the avoidance of doubt, cover will remain uninterrupted for storage at intermediate locations deemed part of transit as per Institute Cargo clauses, provided that storage is incidental to the transit.



Packing:

It is understood and agreed that packing shall be in accordance with standard and customary practices for the type of goods insured and the mode of transit, including loose, bulk, and break bulk shipments where customary.

For the purpose of this insurance, packing shall be deemed acceptable if it conforms to:

- the manufacturer's standard packing, or
- the customary practice of the trade or carriage mode, unless otherwise agreed.

Voyage/Transit Details:

From anywhere in the World to anywhere in the World on a warehouse-to-warehouse basis, including but not limited to:

- Imports, Exports, Domestic Purchase, Inter Unit Transfers, /Depot transfers
- Purchase Returns,
- High Sea Sales/High Seas Purchases,
- Movements to & fro to Job Workers/ Loan License Manufacturers/Third Party Manufacturers,
- Movements of Cargo to & fro for repairs, rectification, fabrication, testing.
- Movement of Plant & Machineries between the assured premises/units/Plants/fabrication yards,
- Mercantile Trade Shipments,
- All kind of transshipments including Multi Modal transshipments,
- Movement of the containers/Reefer Containers/ISO Tanks (loaded and empty) within India or Internationally
- Any other movements for which the Assured has an insurable interest, assumes contractual or legal responsibility, or may be authorized or instructed to insure/or which maybe otherwise at their risk.

Cover shall include transits by sea, air, road, rail, inland waterways, coastal vessels, barges, and multimodal transport, including all customary transshipment and storage incidental to the voyage.

Mode of Transit

Rail and/or Road and/or Sea and/or Air conveyance and/or Inland waterways and/or coastal vessels and/or barges and/or Courier and/or Parcel Post and/or Personal Carriage and/or own transport arranged by the insured and/or hand baggage by employees or authorized representatives of the insured in connection with insured's business activities, whether under contract of affreightment or not.

Cover shall apply irrespective of whether the transport is performed under bill of lading, airway bill, consignment note, or informal arrangements.

Terms of Cover: All Risk and War & SRCC Cover

1. Institute Cargo Clauses "A" CL382 dated 1st January 2009



2. Institute War Clauses (Cargo) CL385 dated 1st January 2009
3. Institute Strikes Clauses (Cargo) CL386 dated 1st January 2009
4. Institute Cargo Clauses (Air) CL387 dated 1st January 2009
5. Institute Strikes Clauses (Air Cargo) CL389 dated 1st January 2009
6. Institute War Clauses (Air Cargo) CL388 dated 1st January 2009
7. Institute War Clauses (Sendings by Post) CL390 dated 1st March 2009
8. Institute Replacement Clause dated 1st December 2008
9. Institute Classification Clause CLS354 dated 1/1/01 to apply to ocean going vessels over 25 years of age, but additional premiums, if any, to be calculated in accordance with agreed scale.
10. Termination of Transit Clause (Terrorism) 2009 JC 2009/056 dated 1st January, 2009
11. Marine Cyber Endorsement
12. Inland Transit (Inland Vessels) Clause – A
13. Inland Transit (Rail or Road) Clause – A
14. ITC Clause B for tail end risk
15. Inland SRCC Clause
16. Cargo termination of storage in transit clause.
17. Concealed Damage Clause (90 days).
18. Extension under Duration clause at port of discharge is required upto 60 days.
19. Risk of loading & unloading is covered.
20. Paramount War Clause
21. In case of Dual Insurance wherein the Equipment's and Materials etc. are covered by the Seller/Contractor/Sub-Contractor etc. Policy and also insured under this Policy, the Primary Liability in such cases to pay claims shall be of the Insurer issuing this policy. This policy is primary and non- contributory.
22. Container Claims Clause
23. Container Cover Clause
24. Registered Post Parcel Clause duly amended for Courier
25. Replacement Clause (Second hand Machinery)
26. Cargo ISM Endorsement
27. FOB Clause – 30 days
28. Sorting Charges
29. Buyer's Interest Clause
30. Contingent Duty Clause
31. Notional Duty Clause
32. Shut Out Clause – 30 days
33. Deliberate Damage Pollution hazard Clause
34. General Average Clause
35. Forwarding Charges Clause
36. Payment on Account Clause – 75% of the assessed amount in case of net claims exceeding Rs. 10 lacs
37. Shortage of Container (including LCL shipments)/ Other Mode of Conveyance
38. Container, Trailer or Railcar Demurrage Charges clause
39. Delay Caused by GA for Temperature Controlled Cargo Brands Clause
40. Contamination and/ or Fumigation Clause
41. Repacking Clause
42. Debris Removal Clause/ Salvage Disposal/ Salvage Incineration/ Destruction Cost
43. Letter of Credit Clause
44. Non Standard Claim Settlement – 90 % of the Assessed Claim Amount
45. Express/ Emergency Freight clause
46. Returned Shipments (OEM Packaging: ICC A/ ITC A; Rest: ICC B/ ITC B)



47. Proof of Loss
48. Wilful Misconduct Clause
49. Claused Bill of Lading
50. Errors & Omissions Clause
51. Knowledge of Occurrence Clause
52. Innocent Assured Clause
53. Pair & Set Clause
54. Missing Goods Clause – 90 days
55. Deviation Clause
56. Bulk Solvents
57. Goods Subject to loss Clause
58. Air Freight Replacement Clause
59. Acceptance of Documents clause
60. Attachment and termination of Risk Clause
61. Shipment Clause
62. Customs Duty Insurance Clause
63. Multi Transit Clause
64. Limitation of Liability clause to be waived in respect of movement of the cargo by assured's own road vehicle/Private Carrier where no LR is issued.
65. Waiver of Recovery Rights/Subrogation for claims upto INR10,00,000/-
66. Waiver of FIR in respect of claims upto INR 10,00,000/- for losses occurring due to theft/Pilferage/Non-Delivery/Shortage/Accident
67. Self-Survey Limit of INR 10,00,000/-
68. Cargo Accumulation Clause
69. Non-Marine Exclusion Clause
70. Political Risk, Financial Guarantee and Credit Risk Exclusion Clause,
71. Additional Custom Duty Clause
72. Escalation Clause – 20%
73. Control of damaged goods clause
74. Forwarding expenses clause
75. Fragile items covered on All Risk Basis
76. Unseaworthiness and unfitness clause admitted
77. Sue & Labour / Loss minimization expenses
78. Extension of cover in respect of damaged interests
79. Cargo ISM Forwarding Charges Clause (at no additional premium) JC 98/023
80. Transshipment Clause
81. Label Clause

Warranties, Other Clauses & Exclusions

1. Communicable Disease Exclusion
2. Over Dimensional Cargo Survey Warranty
3. Excluding shipments from Cuba, North Korea, Syria, Iran and Crimea absolutely.
4. Excluding Shipments to/from and within Ukraine, Russia, Belarus, Ukrainian territorial waters and Russian territorial waters in the Black Sea and the Sea of Azov.
5. War & SRCC cover for all transits whilst the conveyance carrying the interest insured herein is within the HRA as per the latest listed areas in the JWLA (currently JWLA-032) unless specifically agreed by the insurers and additional premium has been paid by the Assured.
6. 50:50 Clause with EAR Policy.
7. Sanction Limitation and Exclusion Clause



8. Five Powers War Exclusion (Amended to Include Triggering of NATO Agreement)
9. Israel &/Or the State of Palestine &/Or Lebanon Condition
10. Institute Cyber Attack Exclusion Clause CL380 dated 10th November 2003
11. Institute Radioactive Contamination, Chemical, Biological, Bio-Chemical and Electromagnetic Weapons Exclusion Clause CL370 dated 10th November 2003

Cancellation of Policy

Policy will not be cancelled or allowed to expire without a written notice to all parties at least sixty (60) days in advance, except in respect of marine cargo insurance where in the case of war, strikes, riots and civil commotion risks insurance may be cancelled by giving seven (7) days' notice to the Insured but forty-eight (48) hours in respect of strikes, riots and civil commotion risks in respect of sending's to or from the United States of America. Cancellation shall become effective on the expiry of the appropriate number of days from midnight of the day on which notice of cancellation is issued by or to the Insurers but shall not apply to any transit insurance that shall have been declared or attached in accordance with contract terms and conditions before the cancellation becomes effective.

Limit per Bottom: Single Shipment limit

(Import) is INR 250 crore (or its equivalent in any other currency)

(For Inland Supply): INR 250 crore (or its equivalent in any other currency).

In case of increase in exchange rate or taxes & duties, the PBL shall be revised upwards during the policy period.

For consignment value more than specified above, the rates shall be mutually agreed.

Limit Per Location Clause: Notwithstanding anything to the contrary contained in this contract, underwriters liability in respect of any one accident or series of accidents arising from the same event in any one location shall not exceed the limit per location amount stated herein i.e. Rs.500 crore.

B: Section – I - Erection All Risks Cover

Section – II - Third Party Liability including Cross Liability

Risk Cover:

The risk coverage under the policy shall commence from the earliest of the following events:

- Upon unloading of goods/consignments at the site of erection/fabrication yard; or
- Start of civil works; or
- Policy start date as notified by PLL

Cover shall remain in force throughout the entire project duration, including during transportation of items/ dismantled items to and fro vendor's work including all risk in course of repair/ reconditioning work at vendor's workshop, transportation from vendor's and supplier's work and warehouse to intermediate site, site stores, handling, shifting, storage at intermediate location of goods/consignments, pre-assembly for the purpose of design, erection, testing and commissioning and until completion of Design, Erection, Testing, all other pre commissioning activities of the plant, Commissioning and Trial Operation of all connected systems in respect of Plant & Machinery covered and commissioning and maintenance period thereafter. The risk coverage under the policy to include any loss or damage caused to the insured property due to any accident in insured property. The risk coverage shall continue till successful commissioning/testing of the project, up to the stabilized load at which the plant is taken over by the principal so that same facilities will be migrated to Mega Policy of PLL. This is to ensure that at no point of time the facility/facilities



remain uninsured.

Insurers hereon explicitly note and agree that this policy is a seamless project insurance policy which will cover all construction/erection/testing/commissioning/ operational and maintenance activities of the entire project works whether in progress, tested, handed over, partially handed over, commissioned/being used etc. and will continue to provide cover on an all risk basis (and not just limited to construction/erection activities) together with all the extensions and add on covers agreed and the cover continues seamlessly until the later of either the final commercial operation date of the entire plant being achieved or until the policy expiry period or any extensions thereof as may be agreed.

Scope of Cover:

All contracts with respect to Project of the Insured attaching during the period of insurance and shall include, but not be limited to, the following:

1. Storage, Design, Erection, testing and commissioning charges including SCE Insurance, including supervision and other incidental services by vendors
2. Testing period (for each unit and Integrated Testing of the overall system)
3. Temporary civil works including project office building, storage sheds, storage yard and associated temporary structures.
4. Project office building, associated equipment, furnishings and fixtures etc.
5. Enabling facilities like temporary roads, temporary lighting, construction power distribution network and construction water systems etc.
6. Permanent civil works such as buildings, foundations, earthwork and associated materials for construction thereon.
7. Cost of material handling at site
8. Cost of contingencies including expenses for foreign experts at site in connection with damage/loss affecting associated plants/facilities.
9. Supervision charges
10. Cost of lubricants, consumables and similar materials required for erection and commissioning.
11. Miscellaneous erection and testing expenses
12. Early works cover for activities undertaken prior to full contract effectiveness where materials form part of the Project
13. Catalysts, including Spent Catalysts
14. Contractor's Charges including Contractor's Overheads, supervision costs and incidental expenses.

The above shall include all materials, items, works and associated costs forming part of the declared value of the Project, whether awaiting erection, under erection, pre-tested, tested, commissioned, temporarily handed over, partially handed over, or used, and all activities incidental to the successful completion of erection, testing, commissioning and stabilization at design load.

Commissioning/Testing Period Cover:

1. Commissioning/Testing period available under the policy shall cease to operate with the commencement of the commercial production. Generally, testing period shall be for a period of 4 (four) months & it starts with the commencement of startup activities which involves all activities required to be performed after pre- commissioning and prior to trial operation.



2. All activities till Erection of complete plant and prior to start up activities shall be treated as Pre-commissioning activities and shall continue under the erection cover. Pre-commissioning activities shall include all activities required to be performed after final tests for all units, offsite, utilities contained within plant, equipment and machineries comprised within the plant to bring the equipment covered in units from an inactive condition to a state ready for trial run and shall include but not limited to checking of systems and vessels, flushing and steam blowing, air blowing of pipelines, system leak checking up to specified pressure, purging the system using inert gas, checking of total instrumentation system of the plant, checking of electrical equipment from proper earthing, installation of resistance conducting operability tests on individual equipment, vessels and systems, integration of all control systems of the unit with the control system of the Project and LNG Terminal and all other activities required to be performed before commissioning and trial run of the unit.
3. Testing would be deemed to have commenced from the date the plant is ready for trial run. Testing involves introduction of hydrocarbon and Equipment/Plant/Unit is tested upto 100% of design Criteria maintained by each separate unit in a stable and controlled manner for a continuous ongoing period of minimum 72 hours (N.B.- Design Criteria are the plant design specification as stipulated in the project design basis.) and will continue till commissioning of the unit. "Commissioning" means pressing in to service the unit(s), equipment (s), Vessels, pipelines(s) machinery and systems and sub systems comprised within the plant in accordance with procedures as approved in Plant Specific Operating Manual and as per the requirement of the Process Licensor, which is the subject matter of the contract after successful testing and trial run of the Plant. In case the commissioning could not be achieved up to the expiry of testing period, the same shall be extended on payment of additional premium as per mutually agreed rates.
4. Testing will also involve part of the existing plant and machineries from the operational unit with an integration to the newly erected plant and such P&M will be involved in integrated testing and commissioning activities. This policy covers such P&M of the operational plant which are involved in testing/ integrated testing phase of new plant, and are covered in respect of any loss or damage occurring during the project and defect liability period for any damage arising out to erection , commissioning and testing work.
If testing period is suspended after commencement of test run for any reason whatsoever, any period during which the test run remained suspended shall be treated as erection period. However, the testing period shall remain reduced by actual duration of testing already carried out in the initial test run. The minimum testing period is one day.
6. In case the plant is under shut down for attending commissioning problems, the period of shut down will be considered as Erection Period. The testing period available for the plant on restart would be for a duration equivalent to the testing period endorsed to the policy initially less the number of days the plant has already run on test / trial mode. Note: Taking a turbine on barring gear shall be treated as erection period. Any similar activity for other plants in the process of shutdown, shall be treated as period of erection and not a period of testing
7. Testing period will be applicable for each unit and integrated testing of plants/units.

INTEREST:**Section I – Erection All Risk/Storage cum Erection “All Risks”**

All risk coverage encompassing and including but not limited to the storage, construction, erection/contract works, testing phases, stocks and supplies of every description and nature,



all real and personal property of every kind, nature and description forming part of/intending to form part of the project, belonging to the Principal Insured (Beneficiary) /contractors/subcontractors of all tiers or for which they are responsible to insure and/or in which the said entities have an insurable interest or property of others in the Insured's care, custody or control or which the Insured entities have agreed to insure prior to loss or damage and all other and such property in which the insured may acquire insurable interest during the course of erection during the policy period. Covering physical loss or damage to the Facilities or part thereof at the site, with an extended maintenance coverage in respect of any loss or damage occurring during the project and defect liability period while the Contractor/sub-contractor is on the site for the purpose of performing its obligations during such period.

The Insurer will also reimburse the Insured for the cost of clearance and removal of debris following upon any event giving rise to an admissible claim under this policy but not exceeding in all the sum (if any) set opposite thereto in the Schedule.

Section II – Third Party Liability including Cross Liability

The Insurer will indemnify the Insured against –

- a) Legal liability for accidental loss or damage caused to property of other persons including property held in trust by or under custody of the Insured for which he is responsible excluding any such property used in connection with erection thereon;
- b) Legal liability (liability under contract excepted) for fatal or non-fatal injury to any person other than the Insured's own employees or workman or employees of the owner of the works or premises or other firms connected with any other erection work thereon, or members of the Insured's family or of any of the aforesaid; directly consequent upon or solely due to the erection of any property described in the Schedule.
- c) Provided that the total liability of the Insurer during the period of Insurance under this clause shall not exceed the limits of Indemnity set opposite thereto in the Schedule.
- d) In respect of a claim for compensation to which the indemnity provided herein applies, the Insurer will, in addition, indemnify the Insured against –
 - i. all cost and expenses of litigation recovered by any claimant from the Insured, and
 - ii. all costs and expenses incurred with the written consent of the Company. The exclusion i.e. War & Terrorism, Sanctions, Limitations and Exclusion Clause, Political Risks Exclusion Clause shall apply to this Section also.

TERRITORIAL LIMITS: Anywhere in India in connection with the Contract

ADD-ON COVERS / CLAUSES & CONDITIONS: Section I and II

Construction/Erection All Risks Policy plus endorsements:

Sr No.	Description	Sub-Limits
1.	Cover for loss or damage due to SRCC/RSMD.	Full Limits
2.	Continuity of cover during operational phase for Unit/Plant tested but awaiting integral testing (along with other units/Plants)	Upto 6 Months. All units to remain under project policy till commissioning of the entire complex.



Sr No.	Description	Sub-Limits
3.	Extended Maintenance (Extended Defects Liability Clause) for Plant & Machinery	24 Months After completion of Testing Period
4.	Maintenance Visit (Limited Defects Liability Clause) for Civil Works	12 Months After completion of Testing Period
5.	Expediting Costs - Cover of extra charges for Overtime, Night Work, Work on Public Holidays and Express Freight including Air Freight	Upto 30% of net claim amount.
6.	Inland Transit to & from off-site storage / vendors/manufacturer premises	Rs. 500 Crore AOA and Full Limit in aggregate.
7.	50:50 Clause	
8.	Offsite storage, Fabrication and / or modification and / or any work related to project at any site (including manufacturing) and respective transits involved.	Rs. 500 Crore AOA at each location & Full Limit in aggregate.
9.	Free Automatic Reinstatement	Upto 25% of sum insured
10.	Escalation	Upto 30%
11.	Professional Fees Clause (To Include Architects, Surveyor & Consulting Engineers Fees or other Professional Fees including Foreign experts visit)	Rs. 75 Crore AOA & Full Limit in aggregate.
12.	Clearance and Removal of debris including removal and disposal of debris, and material foreign / external to the works, desilting & dewatering the works - Per Occurrence.	Rs.100 Crore AOA
13.	Loss Minimization Expenses	Rs. 50 Crore AOA
14.	Firefighting facilities and fire safety at construction sites	At Actuals
15.	Fire fighting expenses	At Actuals
16.	Owners Surrounding Property with FLEXA including during extended maintenance cover.	Upto 50% of Policy Sum Insured but with FLEXA risks
17.	Pro-rata extension of policy period	Extension of the policy for up to 12 months on pro-rata basis irrespective of the claim ratio. Beyond that it will be pro-rata if claim ratio is below 50% and will be mutually agreed if claim ratio is above 50%.
18.	Coverage for Earthquake incl. Tsunami	Full Sum Insured
19.	Coverage for Loss, destruction or damage directly caused by Storm, Cyclone, Typhoon, Tempest, Hurricane, Tornado, Flood or Inundation incl. hailstorm and or any other act of God peril.	Full Sum Insured
20.	Waiver of Subrogation	Agreed
21.	72 hours clause	Covered
22.	Waiver of Contribution	Agreed



Sr No.	Description	Sub-Limits
23.	Design Defect Cover - DE-3 for Civil Works and DE-4 for Electromechanical/ Hydro mechanical, P&M Works	Covered
24.	Multiple Insured Clause	Covered
25.	Additional Custom Duty	Upto INR 250 Cr
26.	Cover for Catalyst	INR 500 Crore AOA
27.	Hydrocarbon Endorsement For Testing & Commissioning	wording as per MR 204 for Hydrocarbon Processing Industries 1 and MR 205 for Hydrocarbon Processing Industries 2 Cover for catalyst during hot testing - INR 500 Crore AOA.
28.	Civil Engineering Works: a) All permanent Civil Engineering Works, b) All Types of temporary works (On Site and Offsite) including Temporary Structure, Site Office, Stores, Godown, Workshop etc., Site Facilities, and Amenities for Labour, worker's camp, warehouses of the Project, Safety & QA / QC Lab / Facilities, P & M and Electrical Infrastructure Works & Other Etc. until the end of usage of such Temporary Facilities provided included in Contract Price while the contract was awarded by the Owner.	Value of Civil Works included in Sum insured. Temporary Works – Rs. 100 Cr.
29.	Camps and Stores Cover	Rs. 25 Crore AOA
30.	Cover Of Leak Search Costs When Laying Pipelines -	Rs. 50 Crore AOA
31.	Construction Machinery Plants And Equipment's -	Rs. 50 Crore AOA
32.	Loss-Payee Clause	
33.	Valuable Papers and Records and Restoration of records/ Plans/ Documents etc.	Rs. 25 Crore AOA
34.	Public Authorities Clause	Upto INR 75 Crore
35.	Free Issue Materials Clause	At Actuals
36.	Non - Vitiation Clause	Covered
37.	Leased Equipment	Rs. 50 Crore AOA
38.	Temporary Repairs	At Actuals
39.	Put to Use	Project Sum Insured and 6 Months
40.	Refund Of Premium for Early Completion of The Project -	Pro-rata on Monthly Basis
41.	Refund of Premium for cancellation of Policy	Pro-rata on Monthly Basis
42.	Endorsement Concerning Storage	Value per storage unit not exceeding the equivalent of Rs. 500 Cr
43.	Claim preparation cost	Rs.10 Crore AOA
44.	Nominated loss adjusters / surveyors clause	As per Annexure - A



Sr No.	Description	Sub-Limits
45.	On Account Payment clause	Upto 75% of initial estimated value of loss
46.	Errors & Omission Clause: It is understood and agreed upon that any accidental error or omission in the description of the covered property shall not prejudice the Insured's interest.	
47.	Coverage for risks of pollution, contamination and seepage	Rs.100 Crore AOA
48.	Cut Through Clause (if applicable)	
49.	Policy Non-cancellable – other than non-payment of premium	
50.	Fragile items like glass, insulation, refractory, insulators etc. as may be due to peril insured	At Actuals
51.	Cover for Property belonging to or held in care, custody or control of the insured	At Actuals
52.	Cessation of Work Clause	Upto 90 Days any one year and 180 days overall policy period
53.	Primary and Non-contributory Clause	Covered
54.	Instalment clause	Yearly instalments
55.	MR 208 Underground cables and pipes	
56.	Environmental Clean-up Cost Cover	Rs. 75 Crore AOA
57.	Vibration Removal & Weakening Support	Limit within overall TPL limits
58.	Destruction Of Undamaged Insured Property	INR 100 Crore AOA
59.	Piling Foundation & Retaining Wall Works Endorsement	Covered
60.	Cover for decontamination	INR 25 Cr AOA
61.	Removal to Place of Safety	
62.	Work away Repairs	
63.	Extended Expiration clause	
64.	Theft and Burglary	Waiver for FIR upto Rs. 1 Cr over and above deductible
65.	Crane hiring charges	Rs. 25 Cr AOA
66.	Coverage for any feed stock, raw material, stock in process to be used for testing and commissioning procedure	Rs. 250 Cr AOA. For Catalysts it is Rs. 500 Cr AOA.
67.	Immediate Repair clause	
68.	Breakage of Glass	
69.	No Control clause	
70.	Agreed Bank Clause	
71.	Loss payee clause	
72.	Suspension of testing period clause	
73.	Intermittent testing cover:	It is noted and agreed that testing may not be continuous, and any suspension of testing period will not reduce the testing period and shall be considered under erection period. The aggregate



Sr No.	Description	Sub-Limits
		period of any intermittent testing shall not exceed the testing period stated under the period of insurance in the RFQ/ policy schedule
74.	Repeat tests/trails cover:	The policy to extend to provide indemnity for the cost of any repeated and/or subsequent tests and/or trials necessarily carried out as a result of Damage to the insured property
75.	Non-Invalidation Clause	
76.	Waiver of Betterment Clause	
77.	Partial Occupancy Clause	
78.	Basis of Claim Settlement on Reinstatement Value basis	Covered

General Exclusions:

1. Institute Radioactive Contamination, Chemical, Biological, Bio-Chemical and Electromagnetic Weapons Exclusion Clause
2. War & Terrorism Exclusion
3. Nuclear Energy Exclusion Clause
4. Sanctions and limitation clause (LMA 3100)
5. Communicable Disease Exclusion
6. Exclusions of crops, Forests and Cultures
7. Cyber Attack Exclusion Clause
8. Political Risks Exclusion Clause
9. Total Asbestos Exclusion Clause
10. Exclusion of ALOP

Date of Proposal and Declaration : 01/11/2025

IN WITNESS WHEREOF, the undersigned being duly authorised has hereunto set his/her hand at LCB DELHI 500300 on this 18th day of November, 2025 .



**For and On behalf of
United India Insurance Co. Ltd.**



Affix Policy Stamp here.

**GENERAL
CONDITIONS
OF
CONTRACT
FOR GOODS**

1. DEFINITIONS

- 1.1 **“PLL” or “Owner”** shall mean Petronet LNG Limited, a Company incorporated in India and registered under the provisions of the Companies Act 1956, having its registered office at World Trade Centre, Babar Road, Barakhamba Lane, New Delhi – 110001.
- 1.2 **“Vendor” or “Seller” or “Supplier”** shall mean the Contractor / bidder / tenderer selected for carrying out the stated work as per the terms and conditions of this tender document and shall include its successors and permitted assigns.
- 1.3 **“Contract” or “Purchase Order”** shall mean Letter of Award / Acceptance which defines the scope of the engagement and the Goods to be delivered by the Vendor as well as the price schedule for the said Goods and all attached exhibit(s) and document(s) referred to therein along with all the terms & conditions mentioned therein together with all and any subsequent modification(s) thereto.
- 1.4 **“Contract Price”** shall mean the price payable to the Vendor under the Contract for the full and proper performance of his contractual obligations.
- 1.5 **“Vendor’s / Seller’s / Supplier’s Representative”** means the person appointed from time to time by the Vendor for execution of the Contract.
- 1.6 **“Goods”** shall mean articles, materials, equipment, design and drawings, data and other tangible or intangible property to be supplied by Seller to complete the contract.
- 1.7 **“Officer in Charge” (OIC) or “Engineer in Charge” (EIC)** shall mean the Officer / Engineer for the time being nominated by the Owner and specified in the respective Purchase Order.
- 1.8 **“Site”** shall mean the site location of as defined in the Tender document, where the supply of goods are required to be effected.

2A MISCELLANEOUS PROVISIONS:

- i. Notwithstanding the subdivision of the document into these separate sections and volumes every part of each shall be deemed to be supplementary to and complementary of every other part and shall be read with and into the Contract so far as it may be practicable to do so.
- ii. Wherever any portion of the Instructions to the Bidder is repugnant of or at variance with any Conditions of Contract, then the provisions of the Conditions of Contract shall be deemed to override the provisions of the Instructions to Bidders and shall prevail to the extent of such repugnance or variations.

- iii. Wherever it is mentioned in the Tender Documents that the Vendor shall perform certain work or provide certain facilities, it is understood that the Vendor shall do so at his own risk and cost, being deemed to be part of the relevant items in the Schedule of Rates whether expressly stated or not.

2B INTERPRETATIONS & PRIORITY OF CONTRACT DOCUMENTS

- i. Once the contract is confirmed and signed, the terms and conditions contained therein shall take precedence over the Vendor bid and all previous correspondence/s if any. The documents forming the Contract are to be read together and interpreted as mutually explanatory of one another (to the extent available in the Tender document / Contract). If there is a direct inconsistency in specific obligation(s), then for the purposes of interpretation, and unless otherwise provided in the Contract, the priority of the Contract documents shall be in following order:
 - a. The Contract Agreement (wherever applicable)
 - b. Letter of Acceptance along with its enclosures
 - c. Scope of Works/ Job Specifications (specific to particular job only, wherever provided)
 - d. Special Conditions of Contract (SCC)
 - e. Technical Specifications (wherever applicable)
 - f. General Conditions of Contract (GCC)
 - g. Instructions to Bidders (ITB)
 - h. Other Documents, if any.
- ii. Words importing the singular number include the plural and vice versa and words importing gender include the masculine, feminine and neuter genders. Unless the context otherwise requires, any reference to a “party” herein is a reference to a party hereto.

3. GENERAL OBLIGATIONS OF THE VENDOR

- 3.1 The Vendor shall, in accordance with and subject to the terms and conditions of this Contract, supply the Goods in accordance with the Scope of Work / Specifications of the Contract and carry out its obligations with all due diligence, professional skills, care and efficiency in accordance with generally accepted professional techniques and practices.
- 3.2 The Vendor shall observe sound management practices and employ appropriate advance technology and safe methods while procuring and supplying the Goods that shall be fit for the purpose for which the same are intended and as specifically provided under the Contract.
- 3.3 The Vendor shall be liable for the stamp duty or any other payments legally payable in respect of this contract as per applicable laws.

4. VENDOR'S REPRESENTATIVE & PERSONNEL

- 4.1. Vendor shall nominate a person ("*Vendor's Representative*") who shall be responsible for and authorized to represent it at all times during the term of the Contract and to receive and to act on any request made by PLL or its representative in performance of any obligations as per the terms of this Contract.
- 4.2. PLL shall be at liberty to object to any nomination in respect to clause 4.1 and may require Vendor to replace, immediately such person by a competent substitute, at no extra cost to PLL.
- 4.3. The Vendor's Representative shall take instructions from OIC for the proper coordination and timely performance of obligations under the terms of the Contract.
- 4.4. The Vendor's Representative shall have to be duly authorized by the Contractor to act or take decision as and when required, on behalf of Vendor under the Contract.

5. CONFIDENTIALITY

- 5.1 The Vendor shall treat all matters, communications, instructions given during the term and in relation to the Contract , strictly confidential and undertakes not to disclose, any information, documents, technical data, experience and know-how shared/exchanged /given to him without the prior written permission of PLL.
- 5.2 The Vendor further undertakes to limit the disclosure/access to the confidential information as mentioned above, only to those of its employees, Implementation Partners etc. who reasonably requires the same for the proper performance of the Contract, provided however that the Vendor shall ensure that each of employees/ Implementation Partner ,with whom the information has been shared , is informed of the confidential nature of the said information and obligations of its nondisclosure.

6. PERFORMANCE BANK GUARANTEE {Not Applicable for OEM & Proprietary Services and Contract Value less than INR 7 Lakhs (exclusive of GST)}

- 6.1 Successful bidder / Vendor shall submit Performance Bank Guarantee from a scheduled commercial bank as per format provided in the Tender document, for the amount equivalent to 10% of the total Contract Value (exclusive of taxes and duties) within 30 days from the date of placement of Purchase Order.
- 6.2 Performance Bank Guarantee shall be kept valid by the Vendor at his cost for 90 days from the last date of the term of the Contract and Warranty and shall be extended from time to time (if so required). It is specifically agreed that no interest shall be payable by PLL on the said Performance Bank Guarantee.
- 6.3 The Performance Bank Guarantee shall cover the entire Contract value including extra jobs / services if any. Further as long as the PBG submitted by Vendor, at the time of award of

the Contract, take care of the extra jobs / services, if any, executed and total executed value are within the awarded Contract price, there is no need for the Vendor to furnish an additional PBG. However in case the total executed value is or is likely to exceed the ceiling of awarded Contract Value, the Vendor shall furnish additional PBG equivalent to 10% of the exceeded value of the contract.

- 6.4 The Company shall have unqualified option under this guarantee to invoke the Performance Bank Guarantee for warranty and/or claim amount thereunder in the event of Vendor / Supplier failing any of the obligations entered into under this Contract or in respect of any amount due from the Vendor / Supplier to PLL.
- 6.5 Failure of the Vendor to comply with the requirements under this Clause for submission of PBG, of requisite amount, within 30 days of issuance of Purchase Order, shall constitute sufficient ground for the annulment of the award, the forfeiture of Bid security and to invoke any other legally permissible actions or remedies available to the PLL.
- 6.6 For itemised annual rate contract, if the duration of Contract is for more than one year, the Vendor shall provide, a PBG of amount equivalent to 10% of one year contract price, however the validity of the PBG under this clause shall be three months beyond Warranty Period or Contract Period whichever is later.

7. SUSPENSION OF THE PERFORMANCE OF THE CONTRACT

- 7.1 PLL may suspend, by giving an advance 15 days written notice (notice of suspension), in whole or in part (if possible) –performance of the contract by the Vendor at any time.
- 7.2 Vendor shall, after receipt of notice of suspension, suspend immediately the supplies of Goods and reduce the expenditure, if any, to a minimum level as agreed between the parties.
- 7.3 Upon suspension of the performance of supplies, the Vendor shall be entitled for the reimbursement of the costs which shall have been actually incurred prior to the date of such suspension. However, the total reimbursement shall be restricted to contract price.
- 7.4 By fifteen days prior notice, PLL may request the Vendor to resume the performance of the supplies, without any additional cost to PLL.
- 7.5 If the period of suspension of the supplies exceeds six months, either party shall be entitled to terminate the Contract according to clause 8 hereunder.

8. TERMINATION

(i) TERMINATION ON EXPIRY OF THE CONTRACT

This Contract shall be deemed to have been automatically terminated on the expiry of the term of the Contract , unless the same is terminated prior to the same in accordance with the other provisions of the contract and unless the Owner has exercised its option to extend this Contract in accordance with the relevant provisions, if any, of this Contract.

(ii) TERMINATION ON ACCOUNT OF FORCE MAJEURE

Either party shall have the right to terminate this Contract on account of Force Majeure, in accordance with clause no this General conditions of the Contract as set forth below.

(iii) TERMINATION ON ACCOUNT OF INSOLVENCY

In the event, the Vendor or its collaborator at any time during the term of this Contract becomes insolvent or makes a voluntary assignment of its assets for the benefit of creditors or is adjudged bankrupt by the court of competent jurisdiction, then the Owner shall be entitled to terminate this Contract , by giving a notice in writing, and all the rights and privileges of Vendor shall stand terminated with immediate effect after two (2) weeks of receipt of said notice by the Contractor / Vendor.

(iv) TERMINATION FOR UNSATISFACTORY PERFORMANCE

If the Owner considers that the performance of the Vendor is unsatisfactory or, is not in accordance with the terms of Contract, the Owner shall notify the Vendor in writing of its unsatisfactory performance along with the detailed reason thereof. The Owner shall then have the option to terminate this Contract by giving a 30 days written notice to the Vendor, if the Vendor fails to cure the reason for that unsatisfaction and /or comply with any requisitions contained in the said written notice given by the Owner.

(v) TERMINATION FOR CONVENIENCE

Notwithstanding anything contained in the Contract, the Owner may, by giving a 30 (Thirty) days written notice, terminate the Contract in whole or in part, if so desires.

In case of such termination, the obligation of the Owner to pay, shall be limited to the extent of price of Goods supplied by the Vendor and which has been duly received by the Owner, as per the provisions of the Contract, up to the date of notice of termination, subject to the Contactor complying with other provisions of the Contract.

(vi) CONSEQUENCES OF TERMINATION AND AMOUNT PAYABLE

In all cases of termination herein set forth, obligation of the Owner to pay, shall be limited to the extent of agreed price of Goods supplied by Vendor as per provision of the Contract up to the date of notice of termination, subject to the Vendor complying with other provisions of the Contract. Notwithstanding the termination of the Contract, the parties shall

continue to be bound by the provisions of this Contract that reasonably require some action or forbearance after such termination.

9. FORCE MAJEURE

In the event of either party being rendered unable by the events which are beyond the control of the party (Force Majeure events) to perform any obligation required to be performed under this Contract, the relative obligation of the party affected by such Force Majeure event shall be suspended, for the period during which such event lasts, subject to a maximum period of 60 days (it is for reference only and will be decided on the basis of duration of Contract), after which both the parties shall be entitled to terminate the Contract by giving not less than 15 days' written notice without any liability for termination.

Upon the occurrence of any such event(s) the party claiming the Force Majeure, shall notify the other party in writing as soon as practicably possible of the occurrence of such Force Majeure event and also the ending of the said Force Majeure event, in writing, not later than 72 hours of the occurrence / ending of the such event.

Force Majeure shall mean and include the following:

- (a) War / Hostilities
- (b) Riot or Civil Commotion
- (c) Earthquake, Flood, Tempest, Lightning, Epidemic, Pandemic or Other Natural Disaster notified or not by the Govt authorities.
- (d) Restrictions imposed by the Government or Other Statutory Bodies, which prevents or delays the execution of the order by the Vendor.
- (e) Lawful Strikes and Lockouts.

10. PRICE REDUCTION SCHEDULE (PRS) {Not Applicable for OEM and Proprietary services and Contract Value less than INR 7 Lakhs (exclusive of GST)}

10.1 In case the Vendor fails to complete the Supplies of Goods within the stipulated period, then, unless such failure is due to Force Majeure event as defined in Clause herein above or due to established default by PLL or its employees, the total Value of Contract shall be reduced by ½ (half) % of the total Value of Contract per week of the period of delay or part thereof subject to a maximum of 5 (five) % of the total Value of Contract, by way of reduction in price for total period of delay.

10.2 The portion of supply completed in all respect which is being used for commercial operation shall not be considered for applying Price Reduction Schedule, if delivered within contractual delivery period.

10.3 The decision of the OIC with respect to applicability of Price Reduction Schedule shall be final and binding on the Vendor.

10.4 The Price Reduction will be calculated on the basis of total Value of Contract / executed Value of Contract (as the case may be) exclusive of taxes and duties.

- 10.5 As per clause 10.1 above, in case of delay in the execution of Contract the Vendor shall raise invoice for reduced value as per Price Reduction Clause. However, in case Vendor has raised the invoice for the full value of the contract, then Vendor shall issue a Credit Note towards the applicable Price Reduction amount.
- 10.6 In case Vendor fails to submit the invoice for reduced value or does not issue credit note as mentioned above, PLL will release the payment to Vendor after by reducing the amount after applying Price Reduction Schedule clause with corresponding reduction of taxes or PLL shall be at liberty to opt for Set-off, adjustment or deduction of the said amount along with applicable taxes, penalties, interest, if any, from any amount due for payment to the Vendor or security deposit, if any, lying with PLL, in future to the him under this contract.
- 10.7 In the event of any financial implication arises on PLL due to issuance of invoice without reduction in price or non-issuance of Credit Note, the same shall be to the account of Vendor and Vendor shall indemnify PLL to that effect.

11. MODIFICATION

During the performance of the Contract, OIC / PLL may make a change within the general scope of this Contract including, but not limited to, changes in methodology and minor additions to or deletions from the Work or with respect to technical and/or commercial aspects including terms of delivery and Vendor shall render the service as changed. Changes of this nature will be affected by a written order (i.e. Amendment) by the PLL. The time of completion of the said job may be extended for the part of the particular job at the discretion of OIC, for only such alterations or substitutions of the Works, as he may consider just and reasonable.

Issuance of acceptance or otherwise in such cases shall not be a ground for extension of agreed delivery date and also shall not affect the performance of contract in any manner except to the extent mutually agreed in writing between the parties, through an amendment of contract. PLL shall not be bound by any conditions or provisions in the Vendor's Bid Forms or acknowledgment of Contract, invoices, packing list and other documents which purport to impose any conditions at variance with or supplemental to the Contract.

Any modification of or addition to the contract shall not be binding unless mutually agreed and made in writing between both the parties.

12. COMPLIANCE OF LABOUR LAW CODES

The Vendor shall comply with all the relevant labour Laws/Codes/Regulations/ rules as amended upto date, applicable to the Vendor's Personnel, including Laws relating to their employment, health, safety, welfare, immigration and emigration. The Vendor shall require its employees to obey all applicable Laws, including those concerning safety at work.

13. ASSIGNMENT / SUBLET

- 13.1 The Vendor shall not, save with previous written consent of the OIC or unless the same has been expressly specified in the Contract, sublet, transfer or assign the Contract or any obligations on the part of Vendor thereof or interest therein or benefit or advantage thereof in any manner whatsoever to any third party, without prior permission of PLL.

Provided, nevertheless, that any such permission given by PLL shall not relieve the Vendor from any obligation, duty or responsibility under the Contract.

13.2 This is pertinent to mention here that the basic scope of Contract cannot be sublet in any case. However, on specific request of the Vendor and subject to written permission of PLL, the Vendor may sublet the allied / incidental jobs related to the contract. Such permission shall not relieve the Vendor from any obligations, duty or responsibility under the Contract and Vendor shall be fully responsible for the same hereunder for the execution and performance of the Contract.

13.3 Sub-letting of entire Contract is specifically prohibited and an undertaking to this effect shall always be given by Vendor along with each invoice / bill.

14. NOTICE

14.1 **TO THE VENDOR:** Any notice to be given to the Vendor or his duly authorised representative under the terms of the Contract may be served by PLL by e-mail or through registered post / Courier at the address / contact information furnished by the Vendor. Proof of issue of any such notice shall be a conclusive evidence of the Vendor having been duly informed of all contents therein.

14.2 **TO PLL:** Any notice to be given to the OIC of the Owner under the terms of the Contract may be served by the Vendor, by e-mail or delivering the same through registered post / Courier at the respective site office.

14.3 A notice shall be effective when delivered or on the date mentioned in notice whichever is later.

15. INTELLECTUAL PROPERTY RIGHTS

The Vendor shall not, in supplying goods under this Contract, knowingly infringe or misappropriate any intellectual property right of a third party, and will take reasonable actions to avoid infringement. The Vendor shall protect, hold harmless, defend and indemnify PLL from and against any claim, lawsuit, or other proceeding, loss, cost, liability, or expense (including court costs and reasonable fees of attorneys and other professionals) to the extent arising out of: (i) any third party claim that a deliverable infringes any patent, copyright, trade secret, or other intellectual property right of any third party; or (ii) any third party claim arising out of the negligent or other tortious acts or omissions by the Vendor or its employees, subcontractors, or agents in connection with or related to the Vendor or the Vendor's performance under this Contract.

16. EXECUTION OF CONTRACT

All the Goods shall be supplied in strict conformity with the provisions of the Contract and with such explanatory detailed specification and instruction as may be furnished from time to time to the Vendor by OIC to the satisfaction of PLL and accept full responsibility for the satisfactory quality of such Goods supplied by them.

Any error in description and any omissions therefrom, shall not vitiate the Contract or release the Vendor from the execution of the whole or any part or any of his obligations under the Contract.

17. INSPECTION, TESTING & EXPEDITING

- 17.1. PLL or its representative shall have the right to inspect and / or test the goods to confirm their conformity to the contract specifications. The inspection & tests shall be conducted on the premises of the seller at the point of delivery and / or at the goods final destination. All reasonable facilities & assistance including access to drawings & production data shall be furnished by seller to PLL free of cost. PLL shall bear all the cost towards Boarding and lodging of PLL personnel visiting Seller's/ Vendor's premise of facility for inspection and expediting purpose.
- 17.2. Preliminary inspection at Seller's works shall not prejudice Purchaser's claim for rejection of the Goods on final inspection at Site or claims under warranty provisions.
- 17.3. If the Goods are not of specification or fails to perform specified duties or are otherwise not performing to the satisfaction of PLL, then PLL shall have the right to reject the Goods or parts thereof and ask for free replacement of the same within reasonable time failing which, PLL shall obtain the Good from some third party to fulfil its requirements at Seller's cost and risk.
- 17.4. Nothing in this clause shall be deemed to deprive PLL and/or affect any of its rights under the Contract which it may otherwise have in respect of such defects or deficiencies or in any way relieve the Vendor of his obligations under the Contract.
- 17.5. Goods rejected by the Purchaser shall be removed by the Seller at his own cost within 14 days (in case of dangerous, infected, corrosion-prone and perishable materials within 8 hours) of notice after repaying the amounts received against the supply. PLL shall in no way be responsible for any deterioration of or damage to the Goods under any circumstances whatsoever.

In case of rejection of Goods, Purchaser shall have the right to recover the amounts, if any, from any of Seller's invoices pending with Purchaser or by alternative method(s). The Purchaser shall also be entitled to recover handling and storage charges for the said period, during which rejected materials are not removed by the Vendor @ 5% of the value of materials for each month or part of a month till the rejected materials are finally disposed off.

18. TRANSIT RISK INSURANCE

- i. All equipment(s) / material(s) shall be insured by Vendor for all transit risks up to unloading at PLL site unless specified otherwise in the Purchase Order, to cover the damages during the transportation and handling of Goods.
- ii. Any damage during the transportation shall be immediately notified by PLL to Vendor as well as the transporter on receipt of goods, for further necessary action for recovery of transit damages.

19. TRANSPORTATION

- i. Unless specifically specified in the Tender document, the Vendor shall supply the Goods on Carriage and Insurance Paid (CIP) / Delivered at (DAP) basis.
- ii. Where the Vendor is required under the Contract to deliver the Goods on the other modes of delivery viz. Freight on Board (FOB) / Free Carrier (FCA) / Free Alongside (FAS) / Cost and Freight (CFR) / Cost, Insurance and Freight (CIF) / Delivered duty paid (DDP) etc., the responsibility of Vendor shall be to arrange for transportation of goods from their works as per standard practice defined under INCOTERMS 2020.

20. WARRANTY

The Vendor shall warrant that everything to be supplied under the contract shall be free from all defects and faults in material, workmanship and manufacturing defects and same shall be of the highest grade and consistent with the established and generally accepted standards of the materials of the type supplied and in full conformity with the specifications drawings or samples, if any, and shall if operable, operate, properly. This warranty shall survive inspection and acceptance of the goods but shall expire 12 months from the date of commissioning / operations or 24 months from the date of dispatch, whichever is earlier.

21. INVOICE

In case where documents are not routed through Bank, original plus one copy of invoice shall be directly sent to OIC immediately after dispatch with copies to purchaser and the consignee mentioned in Contract / Purchase Order. Invoice must bear the Purchase Order no. with date and should also indicate the dispatch particulars. It may be noted that the documents will be retired only if the dispatches are made as per the terms of the Purchase Order.

22. PACKING & MARKING

While dispatching ordered stores, it will be the responsibility of the Vendor to properly pack the consignment so as to enable its delivery at destination free from loss, damage or

pilferage. Each packing must contain a list of stores (“Packing List”) packed therein. Each packing / bundle must be prominently marked with order no. and packing no. & consignee name & address.

23. DESPATCH DOCUMENTS

The Vendor will intimate dispatch particulars to PLL through e-mail at the time of dispatch of goods.

The dispatch documents shall consists of Invoice, Challan, Packing List, GR/LR, inspection/ Test Certificate and any other document(s) as mentioned in the P.O. Copies of dispatch documents should reach PLL well in advance failing which any demurrage / wharfage etc. incurred on account of late / non-receipt of dispatch document / wrong dispatches of consignment will be recovered from supplier. In case of documents through Bank, it may be noted that the documents will be retired only if the dispatches are made as per the terms of the Purchase Order.

24. REPEAT ORDER

PLL reserves the right within six months of order, to place repeat order up to 50% of the total order value without any change in unit price or other terms and conditions of the contract.

25. RECOVERY OF SUMS DUE

All costs, damages or expenses which the PLL may have suffered, for which under the Contract, Seller is liable, may be recovered by the PLL (he is hereby irrevocably authorized to do so) from any money due to or becoming due to the Vendor under this Contract or other Contract and / or may be recovered by action at law or otherwise if the same due to the Vendor is not sufficient to recover the recoverable amount, the Vendor shall pay to the PLL, on demand, the balance amount.

26. PAYMENTS ETC. NOT TO AFFECT RIGHTS OF THE PLL

No sum paid on account by the PLL nor any extension of the date for completion granted by the PLL shall affect or prejudice the rights of the PLL against the Vendor or relieve the Vendor of his obligation for the due fulfilment of the Contract.

Losses due to non-compliance of Instructions, losses or damages suffered by PLL owing to the Vendor’s failure to adhere to any of the instructions given by the PLL in connection with the order execution shall be recoverable from the Seller.

27. CUT-OFF DATES

No claims or correspondence on this Order shall be entertained by the PLL after 90 days after expiry of the performance guarantee (from the date of final extension, if any)

28. FALL CLAUSE

- 28.1. The price charged for the materials supplied under the Contract by the Vendor shall in no event exceed the lowest price at which the Vendor or his agent/principal/dealer, as the case may be, supplies the materials of identical description to any Persons/Organizations including the Purchaser or any Department of the Central Govt. or any Department of a State Govt. or any Statutory Undertaking of the Central or State Govt. as the case may be, during the term of the Contract.
- 28.2. If at any time during the said Term , the Vendor or his agent/principal/dealer, as the case may be, reduces the sale price, sells or offers to sell such materials to any persons/organizations including the Purchaser or any Deptt. Of Central Govt. or State Govt. as the case may be, at a price lower than the price chargeable under the Contract, he shall forthwith notify such reduction or sale or offer of sale to the PLL and the price payable under the Contract for the Goods supplied after the date of coming into force of such reduction or sale or offer of sale shall stand correspondingly reduced.
- 28.3. The supplier shall furnish the following certificate to PLL along with each bill for payment for supplies made against this order: - "I/We certify that there has been no reduction in sale price of the items/goods/materials of description identical to those supplied to the PLL under the order herein and such items/goods/materials have not been offered/sold by me/us to any person/organizations including the Purchaser or any Deptt. of Central Govt. or any Deptt. of State Govt. or any Statutory Undertaking of the Central or State Govt. as the case may be upto the date of bill/during the Term of this Contract whichever is later, at a price lower than the price charged to the PLL under the Contract".

29. INDEMNITY AND INSURANCE

The Vendor shall purchase and maintain at his cost, such insurance as will protect the parties from any claim which may arise out of or result from the Vendor's performance of its obligations or otherwise under the Contract, whether such claim may arise due to action or omission by the Vendor or a Sub-Vendor or by anyone directly or indirectly contracted or used by any of them, or by anyone for whose acts any of them may be liable.

All policies of insurance referred to in this Clause shall be endorsed to specify that they are primary to and not excess to or on a contributing basis with any insurance or self-insurance maintained by Owner and Vendor (and their respective Affiliates) or any Sub Vendors in respect of losses arising out of or in connection with the Work.

Further, the Vendor shall indemnify and keep indemnified PLL and its every member, officer and staff against all actions, proceedings, claims, costs and expenses whatsoever in respect of or arising out of any failure or default by the Vendor in due performance of its obligations under this Contract.

The Vendor shall undertake to provide comprehensive accident insurance coverage in respect of every employee employed by it for carrying out PLL's job.

The Vendor hereby agrees to indemnify and keep indemnified PLL and its employees, in case PLL faces any legal actions, proceedings, claims, costs, expenses, damages, loss on account of breach, if any, terms and conditions of the Contract including infringement of IPR by the Vendor.

30. TAXES AND DUTIES

- 30.1. Unless otherwise specified in the NIT / Tender document, all duties, taxes and other levies including cess on all duties, taxes and other levies (excluding GST) payable by the Vendor under the Contract shall be included in the schedule of prices submitted by the Vendor as per format.
- 30.2. The monthly bill in duplicate will have to be submitted by the Vendor to the OIC at the rates specified and the payment will be made after verification of the same. On no account any extra payment whatsoever will be made to the Vendor for this contract. The bills should be supported by copies of payment including statutory payments in respect of each personnel engaged by the Vendor.
- 30.3. The Vendor shall be fully and exclusively responsible for the payment (and liable for all consequences in the event of default) of all contribution and taxes for unemployment compensation, insurance and old age pensions and amenities now or hereafter imposed by any law of the Government / local bodies which are imposed with respect to or covered by the wages, salaries or other compensation paid to the persons employed by the Vendor.
- 30.4. After award of work, GST as applicable shall be paid by PLL to the Vendor based on the Taxable invoices issued by the Vendor.
- 30.5. PLL shall accept only E-Invoice compliant invoices, in case the provisions are applicable.
- 30.6. TDS along with surcharge as applicable at the prevailing rate on the gross amount billed shall be deducted from the Vendor's invoice as per applicable laws.

30.7. Change in Law

If at any time any change in Indian Law causes an imposition of any new tax in India, that was not in existence as on Bid Submission Date / Date of Letter of Award (LoA), which is applicable to the Vendor under this Contract, then either Party may request a revision of the payments made or to be made to Vendor under this Contract. Either Party, as the case may be, shall provide notice to the other Party of such request setting forth the proposed amount along with relevant details and calculations relating to, such change.

The Parties shall promptly, but in no case later than fifteen (15) days from the date of such written request, discuss in good faith and mutually agree to revise the payments pursuant to such change along with the basis of such revision and the effective date of such revision.

For avoidance of any doubt, it is clarified that any new tax shall be to the account of PLL. Similarly, the benefit of any decrease in the corporate tax rates shall be passed on by the Vendor to PLL. either by way of refund or an adjustment in the payments due and payable to Vendor in accordance with this Contract.

31. UNETHICAL PRACTICES

- 31.1 The Vendor represents, warrants and agrees that no Person has been retained or employed to solicit this Contract upon any arrangement or understanding for the payment of any commission, fee or other compensation of any kind, except for compensation to bona fide employees of the Vendor.
- 31.2 The Vendor further represents and warrants that neither it nor any of its Affiliates nor any of its or their respective personnel have made, received, provided or offered and the Vendor agrees that neither it nor any such other entity or Person shall make, receive, provide or offer, any gift, entertainment, payment, loan or other consideration for the purpose of influencing any person to any course of conduct in any way relating to or affecting this Contract.
- 31.3 Without in any way limiting the nature of breaches which could constitute 'material breaches' of this Contract / LOA for the purposes of clause 8 of GCC, Parties hereby expressly agree that breach of the foregoing representations and warranties shall constitute a material breach of this Contract and shall give Owner the right to immediately terminate this Contract pursuant to Clause 8 of GCC.

32. DISPUTE RESOLUTION

- 32.1. In the event of a dispute between the Owner and the Vendor regarding , arising out of, relating to or in connection with this Contract, including, its application, interpretation, breach, termination, validity or invalidity (a **“Dispute”**), prior to the initiation of any legal action or proceeding (but only in accordance with and as permitted by this Contract) in relation to a Dispute, the OIC and the Vendor's Representative shall, upon the written request of either the Owner or the Vendor (a **“Request”**), use their best efforts in good faith to reach at a reasonable and equitable resolution in relation to the Dispute.
- 32.2. If the OIC and Vendor's Representative are unable to resolve the Dispute within thirty (30) days of receipt by either Party of a Request, either Party may by a written notice (a **“Notice”**), refer the matter for resolution by good faith negotiation between their respective senior officers with appropriate decision making powers and who shall not have had any substantive involvement in the matters related to the Contract, unless the Parties otherwise agrees.
- 32.3. If the senior officers are unable to resolve the Dispute within thirty (30) days of receipt by either Party of a Notice (or such other period as may be mutually agreed), either Party may resort to the other Dispute resolution provisions.
- 32.4. The Parties agrees to use their best efforts to resolve all Disputes promptly, amicably, equitably and in good faith.

33. ARBITRATION {Applicable for Contract Value more than INR 2 Crores}

In case the dispute is not resolved as mentioned above, the same shall be referred to Arbitration comprising of an Arbitration Tribunal of three arbitrators, of whom each Party shall nominate one arbitrator. The third arbitrator (who shall act as Presiding Arbitrator) shall be nominated by the two arbitrators, nominated by the Parties.

The arbitration shall be conducted in accordance with the provisions of the (Indian) Arbitration and Conciliation Act, 1996 (“Act”) as amended from time to time. The venue of arbitration shall be in New Delhi, India and proceedings shall be conducted in English language.

The Award of the arbitral tribunal shall be final and binding upon the Parties.

Notwithstanding the fact that settlement of dispute(s) (if any) under arbitration may be pending, the parties hereto shall continue to be governed by and perform the work in accordance with the provisions under this Contract.

34. JURISDICTION AND APPLICABLE LAW

This Contract including all matter connected to this Contract, shall be governed by the laws of India and shall be subject to exclusive jurisdiction of the courts of New Delhi.

35. LICENSE / CERTIFICATE / CONSENT / APPROVAL {IF APPLICABLE}

Seller shall procure, at his expense, all necessary permits, certificates and licences required by virtue of all applicable laws, codes, regulations, ordinances and other rules in effect at the place where any of the work is to be performed, and Seller further agrees to hold PLL harmless from liability or penalty which might be imposed by reason of any asserted or established violation of such Codes, laws, regulations, ordinances or other rules. PLL will provide necessary permits for Seller’s personnel to undertake any work in India in connection with Contract.

The consent / approval / license / certificate for carrying out the work from the concerned authority shall be kept valid for the entire duration of the contract and it shall be the sole responsibility of the Vendor / bidder to maintain / renew the validity of the such consent / approvals thereunder from time to time, failing which it may lead to cancellation of contract.

36. LIMITATION OF LIABILITY

Notwithstanding anything contrary contained herein, the aggregate total liability of Supplier to Employer under the Contract shall not exceed the Total Contract Value, except that this clause shall not limit the liability of the Supplier for following:

(a) In the event of breach of any Applicable Law;

(b) In the event of fraud, wilful misconduct or illegal or unlawful acts, or gross Negligence of the Supplier or any person acting on behalf of the Supplier; or

(c) In the event of acts or omissions of the Supplier which are contrary to the most elementary rules of diligence which a conscientious Supplier would have followed in similar circumstances; or

(d) In the event of any claim or loss or damage arising out of infringement of Intellectual Property; or

(e) For any damage to any third party, including death or injury of any third party caused by the Supplier or any person or firm acting on behalf of the Supplier in executing the job.

However, neither party shall be liable to the other Party for any indirect nor consequential loss or damage like loss of use, loss of profit, loss of production or business interruption which is connected with any claim arising under the Contract.

37. COMPLIANCE OF PLL INSIDER'S TRADING

By virtue of association / engagement with Petronet LNG Limited (PLL), it is likely that certain Unpublished Price Sensitive Information (UPSI) as defined under "Code for Prevention of Insider Trading in the Securities of PLL" (hereinafter called Code), copy of which is hosted on the website of the company www.petronetlng.com, that is not generally available and which upon becoming generally available is likely to materially affect the price of the securities issued by PLL, might be shared with you / your organization. It is hereby cautioned that you or any of your team members or immediate relatives thereof or your organization, should not trade in the securities of PLL while in possession of such UPSI or communicate such UPSI to any person except in furtherance of legitimate purposes (as defined in the Code), performance of duty or discharge of legal obligations. Any trades in securities of PLL, directly or indirectly, while in possession of any UPSI would be presumed to have been motivated by the knowledge and awareness of the UPSI and the onus to prove that trades were executed otherwise would be on you or any of your team members or your organization as the case may be. It is therefore advised that all concerned as stated above must familiarize himself/themselves with the "Code for Prevention of Insider Trading in the Securities of PLL", copy of which is hosted on the website of the company.

Accordingly, it must be ensured that any UPSI, whenever received from the company:

- (a) shall be used solely for the purpose for which it is being disclosed;
- (b) shall be preserved and the secrecy of such information shall be maintained;
- (c) shall not be disclosed to any third party;
- (d) shall be kept securely and properly protected against theft, damage, loss and unauthorized access (including access by electronic means) by deploying means similar to those being used to secure its own confidential information;
- (e) to notify PLL immediately upon becoming aware that any of the confidential information has been disclosed to or obtained by a third party.

It may be noted that any violation in dealing with UPSI shall be considered as breach of terms of engagement / Contract and PLL shall take necessary action for such breach in addition to reporting to SEBI for taking necessary action under SEBI (Prohibition of Insider Trading) Regulations, 2015 or subsequent amendments thereof. Further, SEBI may take any

action including levy of penalty etc. as per SEBI Regulations in this regard in case of any violation in dealing with UPSI at your end.

38. PROCEDURE FOR PUTTING AN AGENCY ON HOLIDAY AND BANNING LIST

Procedure for putting an agency on Holiday and Banning list is enclosed at Attachment-I .

**39. PROCEDURE FOR EVALUATION OF PERFORMANCE OF VENDORS/
CONTRACTORS/ CONSULTANTS**

Procedure for evaluation of performance of Contractor is enclosed at Attachment-II

PROCEDURE FOR PUTTING AN AGENCY ON HOLIDAY AND BANNING LIST

DEFINITION:

“Agency” shall mean Bidder / vendor / Contractor / Supplier / Consultant of Petronet LNG Limited (PLL).

“Corrupt practice” means the offering, giving or soliciting of anything of pecuniary advantage value to improperly influence by abuse of entrusted power, the procurement process or in contract execution.

“Fraudulent practice” includes any act or omission committed by an agency / entity by misrepresenting, misleading/submitting false document and or false information or concealment of facts in order to influence the procurement process as well as during the execution of contract.

“Collusive practice” amongst bidders means a scheme or arrangement designed to establish bid prices at artificial non-competitive level and to deprive PLL of the benefit of free and open competition.

“Coercive practice” means impairing or harming or threatening to impair or harm directly or indirectly, any agency or its property to influence the improper actions of an agency, obstruction of any investigation or auditing of a procurement/contract process.

A. INTRODUCTION:

In the course of the bidding / contracting (procurement, works and service contracts), agencies (bidder(s) / vendor(s) / supplier(s) / contractor(s) / consultant(s)) are expected to adopt ethics of highest standards and a high degree of integrity, safety & quality consciousness, commitments and sincerity towards terms and conditions of the tender(s) / order (s) undertaken. Any aberration, deviation and violation from the expected behaviour of the Agencies need to be dealt appropriately by putting the Agencies on holiday or banning list for specific periods so that it becomes a deterrent for all the future transactions.

1. HOLIDAY LIST

An Agency may be put in the Holiday list in case if:

- a. It has refused to accept LOA/LOI/Purchase order/contract (order value 10 Lakhs and above) after the same is issued within the period of Bid validity and as per agreed terms & conditions or,
- b. The materials supplied by the Agency are found to be defective and fails to perform during its use/operation. Premature failure of the work executed by contractor/failure of equipment during the operation, and not giving the desired result as per provision of the contract or,
- c. The rating of the vendor/ consultant come to be POOR as per Procedure For Evaluation Of Performance Of Vendors/ Contractors/ Consultants

- d. It is declared or is in the process of being declared bankrupt, insolvent, wound up, dissolved or partitioned; or
- e. It persistently violates provisions of labor laws/ regulations / rules, safety norms, environmental norms or other statutory requirements; or

2. BANNING LIST

Any Agency can be put in the Banning list in case if:

- a. if it is involved in an instance of Corrupt, Fraudulent, Collusive and Coercive practice against PLL.
- b. it is involved in fraudulent activity, wilful misconduct, misrepresentation, mis-declaration, security considerations or,
- c. it has indulged in any type of forgery or falsification of records; or
- d. the proprietor of the firm, its employee(s), partner(s) or representative(s) is / are convicted by a court of law for offences involving moral turpitude in relation to business dealings.
- e. There is strong justification for believing that the proprietor or employees or representatives of firm have been guilty of malpractices such as bribery, corruption, fraud, substitution of tenders, interpolations, misrepresentation, evasion or default in payment of any tax levied by law.

B. DELETED

C. Procedure To Be Followed For Irregularities Observed At Various Stages

1. Irregularities noticed during Bidding Process:

If any irregularity mentioned in Clause A.2 is observed during bidding process/ bids evaluations stage the bid of such Bidder (s), it shall be rejected after due approval from the competent authority and following the due procedure.

In case the irregularities are found to be true the EMD/ Bid security of such Bidder shall be forfeited.

2. Irregularities noticed after award of contract

(i) During execution of contract:

In case irregularities are found to be true the contract shall be suspended with immediate effect.

The Agency shall be banned / put on holiday list for future business with PLL for a period specified in Clause (D) below from the date of issue of banning / holiday order.

The PBG submitted by such agency against such order/ contract shall also be forfeited.

The amount that may have become due to the contractor on account of work already executed by him shall be payable to the contractor and this amount shall be subject to adjustment against any amounts due from the contractor under the terms of the contract.

(ii) After execution of contract and during Defect liability period (DLP)/ Warranty/ Guarantee Period:

In case irregularities are found to be true, the Agency shall be banned / put on holiday list for future business with PLL for a period specified in Clause (D) below from the date of issue of banning / holiday order.

The PBG submitted by such Agency against such order/ contract shall also be forfeited.

(iii) After expiry of Defect liability period (DLP)/ Warranty / Guarantee Period.

In case irregularities are found to be true, the Agency shall be banned / put on holiday list for future business with PLL for a period specified in Clause (D) below from the date of issue of banning / holiday order.

3. Exceptional Cases:

(i) However, as an exception, the ongoing order(s)/ contract(s) where irregularities has been observed, the Agency may be allowed to complete the supply/ job in case of following situations:

- a) No adverse performance of the job as per scope of work (performance to be reviewed on quarterly basis) and.
- b) The supply/ jobs are of critical nature in terms of adverse impact on the Project Completion Schedule and or prospective revenue generation.

(ii) DELETED

(III) The Performance Bank Guarantee (PBG), of such Agency against the order (s)/ contract (s) where Agency is allowed to complete the supply/ job in above exceptional case shall not be forfeited on this ground. The contract shall be executed as per terms and conditions of the contract. However, the Agency shall be put on Banning / Holiday List from the date of banning order.

4. Effect of Banning on other ongoing Contracts/ Tenders

- (i) If an Agency is put on Banning / Holiday List, such Agency should not be considered in ongoing tenders/ further tenders.
- (ii) However, if such an Agency is already executing other order(s)/ contracts (s) where no irregularities are observed, the agency should be allowed to continue till its completion without any further increase in scope except those incidentals to original scope mentioned in the Contract.

D. HOLIDAY / BANNING PERIOD

- (i) The Agency can be put on Holiday for a time period ranging from 6 months to 3 years. The committee examining the case shall propose the holiday period in its recommendation.
- (ii) Banning period shall be reckoned from the date of banning order and shall be of 3 years.
In exceptional cases where the act of vendor/ contractor is a threat to the National Security, the banning shall be for indefinite period.

**PROCEDURE FOR EVALUATION OF PERFORMANCE OF VENDORS/
CONTRACTORS/ CONSULTANTS**

1 GENERAL

A system for evaluation of Vendors/ Suppliers/Contractors/ Consultants and their performance is a key process and important to support an effective purchasing & contracting function of an organization.

Performance of all participating Vendors/ Suppliers/Contractors/ Consultants need to be closely monitored to ensure timely receipt of supplies from a Vendor, completion of an assignment by a Consultant or complete execution of order by a contractor within scheduled completion period. For timely execution of projects and meeting the operation & maintenance requirement of operating plants, it is necessary to monitor the execution of order or contracts right from the award stage to completion stage and take corrective measures in time.

2 OBJECTIVE

The objective of Evaluation of Performance aims to recognize and develop reliable Vendors/ Suppliers/Contractors/ Consultants so that they consistently meet or exceed expectations and requirements.

The purpose of this procedure is to put in place a system to monitor performance of Vendors/ Suppliers/Contractors/ Consultants associated with PLL in Projects and in O&M so as to ensure timely completion of various projects, timely receipt of supplies including completion of works & services for operation and maintenance of operating plants and quality standards in all respects.

3 METHODOLOGY

i) Preparation of Performance Rating Data Sheet

Performance rating data Sheet for each and every Vendor/ Supplier/Contractor/ Consultant for all orders/Contracts with a value of Rs. 7 Lakhs and above is recommended to be drawn up. These data sheets are to be separately prepared for orders/ contracts related to Projects and O&M. Format, Parameters, Process, responsibility for preparation of Performance Rating Data Sheet are separately mentioned.

ii) Measurement of Performance

Based on the parameters defined in Data Sheet, Performance of concerned Vendor/ Supplier/Contractor/ Consultant would be computed and graded accordingly. The measurement of the performance of the Party would be its ability to achieve the minimum scoring of 60% points in the given parameters.

- iii) **Initiation of Measures:**
Depending upon the Grading of Performance, corrective measures would be initiated by taking up the matter with concerned Vendor/ Supplier/Contractor/ Consultant. Response of Vendor/ Supplier/Contractor/ Consultant would be considered before deciding further course of action.
- iv) **Implementation of Corrective Measures:**
Based on the response of Vendor/ Supplier/Contractor/ Consultant, concerned Engineer-in-Charge for the Projects and/or OIC in case of O&M would recommend for continuation or discontinuation of such party from the business of PLL.
- v) Orders/contracts placed on Proprietary/OEM basis for O&M will be evaluated and, if required, corrective action will be taken for improvement in future.

4 EXCLUSIONS:

The following would be excluded from the scope of evaluation of performance of Vendors/ Suppliers/Contractors/ Consultants:

- i) Orders/Contracts below the value of Rs. 7 Lakhs (increase value).
- ii) One time Vendor/ Supplier/Contractor/ Consultant.
- iii) Orders for Misc./Administrative items/ Nonstock Non valued items.

However, concerned Engineer-in-Charge /OICs will continue to monitor such cases so as to minimize the impact on Projects/O&M plants due to non-performance of Vendors/ Suppliers/Contractors/ Consultants in all such cases.

5 PROCESS OF EVALUATION OF PERFORMANCE OF VENDORS/ SUPPLIERS/ CONTRACTORS/ CONSULTANTS

5.1 FOR PROJECTS

- i) Evaluation of performance of Vendors/ Suppliers/Contractors/ Consultants in case of PROJECTS shall be done immediately with commissioning of any Project.
- ii) On commissioning of any Project, EIC (Engineer-in-charge)/ Project-in-charge shall prepare a Performance Rating Data Sheet (Format- 1) for all Orders and Contracts excluding cases under para 4.0.
- iii) Depending upon the Performance Rating, following action need to be initiated by Engineer-in-charge/Project-in-charge:

S.No.	Performance Rating	Action
1	POOR	Seek explanation for Poor performance

2	FAIR	Seek explanation for Fair performance
3	GOOD	Letter to the concerned for improving performance in future
4	VERY GOOD	No further action

- iv) Reply from concerned Vendor/ Supplier/Contractor/ Consultant shall be examined. In case of satisfactory reply, Performance Rating data Sheet to be closed with a letter to the concerned for improving performance in future.
- v) When no reply is received or reasons indicated are unsatisfactory, the following actions need to be taken:
 - A. Where performance rating is “POOR”
Recommend such defaulting Vendor/Supplier/Contractor/ Consultant for putting on Holiday as per “Procedure for Putting an Agency on Holiday and Banning List" As mentioned elsewhere in the Tender document
 - i) Poor Performance due to reasons other than Quality: **One Year**
 - ii) Poor Performance on account of Quality (if any mark obtained against Quality parameter is less than 30): **Two Years**
 - iii) Poor Performance leading to termination of contract or Offloading of contract due to poor performance solely attributable to Vendor/Supplier/Contractor/Consultant or Repeated Offence: **Three Years**

Non-performance of a Vendor/Supplier/Contractor/Consultant leading to termination of Contract/ Order such Vendor/ Supplier/ Contractor/Consultant are also to be considered for Holiday.

In all such cases, concerned site will put up recommendation and putting the party on Holiday list as per process defined in “Procedure for putting an agency in Holiday list and Banning list”

- B. Where Performance rating is “FAIR”

Recommend for issuance of warning to such defaulting Vendors/Contractors/Consultants to improve their performance.

5.2 FOR CONSULTANCY JOBS

Monitoring and Evaluation of consultancy jobs will be carried out in the same way as described in para 5.1 for Projects except the functions of Project Manager will be performed by concerned In-charges of user Deptts. Such as Project Development, Business Development, HR, Finance, HSE etc.

5.3 FOR OPERATION & MAINTENANCE

- i) Evaluation of performance of Vendors/ Suppliers/Contractors/ Consultants in case of Operation and Maintenance shall be done immediately after execution of order/ contract.
- ii) After execution of orders a Performance Rating Data Sheet (Format attached herewith) shall be prepared for Orders by C&P and for Contracts/Services by respective Engineer-In-Charge excluding cases under para 4.0.
- iii) Depending upon Performance Rating, following action need to be initiated by C&P

Sl. No.	Performance Rating	Action
1	POOR	Seek explanation for Poor performance
2.	FAIR	Seek explanation for Fair performance
3	GOOD	Letter to the concerned for improving performance in future.
4	VERY GOOD	No further action

- iv) Reply from concerned Vendor/ Supplier/Contractor/ Consultant shall be examined. In case of satisfactory reply, Performance Rating data Sheet to be closed with a letter to the concerned for improving performance in future.
- v) When no reply is received or reasons indicated are unsatisfactory, the following actions need to be taken:
 - A. Where performance rating is “POOR”
Recommend such defaulting Vendor/Supplier/Contractor/ Consultant for putting on Holiday as per “Procedure for Putting an Agency on Holiday and Banning List" As mentioned at Annexure I:
 - i) Poor Performance due to reasons other than Quality: **One Year**
 - ii) Poor Performance on account of Quality (if any mark obtained against Quality parameter is less than 30): **Two Years**
 - iii) Poor Performance leading to termination of contract or Offloading of contract due to poor performance solely attributable to Vendor/Supplier/Contractor/Consultant or Repeated Offence: **Three Years**
 - B. Where Performance rating is “FAIR”

Recommend for issuance of warning to such defaulting Vendors/Contractors/Consultants to improve their performance.

FORMATS

FORMAT-1

PETRONET LNG LIMITED

PERFORMANCE RATING DATA SHEET

- i) Project/Work Centre :
- ii) Order/ Contract No. & date :
- iii) Brief description of Items :
Works/Assignment
- iv) Order/Contract value (Rs.) :
- v) Name of Vendor/Supplier/ :
Contractor/ Consultant
- vi) Contracted delivery/ :
Completion Schedule
- vii) Actual delivery/ :
Completion date

Performance Parameter	Delivery/ Com Performance	Quality Perform	Reliability Performance#	Total
Maximum Mark	40	40	20	100
Marks Allocated				

Note:

Remarks (if any)

PERFORMANCE RATING (**)

Note:

(#) Vendor/Supplier/Contractor/Consultant who seek repeated financial assistance or deviation beyond contract payment term or seeking direct payment to the sub-vendor/sub-

contractor due to financial constraints, then '0' marks should be allotted against Reliability Performance.

(*) Allocation of marks should be as per enclosed instructions

(**) Performance rating shall be classified as under:

Sl. No.	Range (Marks)	Rating
1	60 & below	POOR
2	61-75	FAIR
3	76-90	GOOD
4	More than 90	VERY GOOD

Signature of Authorised Signatory:

Name:

Designation:

Instructions for allocation of marks

1. Marks are to be allocated as under:

1.1 DELIVERY/ COMPLETION PERFORMANCE 40 Marks

Delivery Period/ Completion Schedule	Delay in Weeks	Marks
a) Upto 3 months	Before CDD	40
	Delay upto 4 weeks	35
	” 8 weeks	30
	” 10 weeks	25
	” 12 weeks	20
	” 16 weeks	15
	More than 16 weeks	0
b) Above 3 months	Before CDD	40
	Delay upto 4 weeks	35
	” 8 weeks	30
	” 10 weeks	25
	” 16 weeks	20
	” 20 weeks	15
	” 24 weeks	10
More than 24 weeks	0	

1.2 QUALITY PERFORMANCE

40 Marks

For Normal Cases: No Defects/ No Deviation/ No failure		40 marks
i. Rejection/Defects	Marks to be allocated prorata basis for accepted Quantity as compared to Quantity for normal cases	10 marks
ii. When quality Failure encountered System integration and satisfactory the system	Failure of severe nature	0 marks
	- Moderate nature	5 marks
	- low severe nature	10-25 marks
iii. Number of Deviations	1. No deviation:	5 marks
	2. No. of deviations < 2:	2 marks
	3. No. of deviations > 2:	0 marks

1.3 RELIABILITY PERFORMANCE

20 Marks

A	FOR WORKS/CONTRACTS	
i)	Submission of order acceptance, agreement, PBG, Drawings and other documents within time	4 marks
ii)	Mobilization of resources as per Contract and in time	4 marks
iii)	Liquidation of Check-list points	4 marks
iv)	Compliance to statutory and HS&E requirements or Reliability of Estimates/Design/Drawing etc. in case of Consultancy jobs	4 marks

v)	Timely submission of estimates and other documents for Extra, Substituted & AHR items	4 marks
B.	FOR SUPPLIES	
i)	Submission of order acceptance, PBG, Drawings and other documents within time	5 marks
ii)	Attending complaints and requests for after sales service/ warranty repairs and/ or query/ advice (upto the evaluation period).	5 marks
iii)	Response to various correspondence and conformance to standards like ISO	5 marks
iv)	Submission of all required documents including Test Certificates at the time of supply	5 marks

स्वदेशी सामग्रियों के लिए
पैकिंग, मार्किंग, शिपिंग और दस्तावेज विनिर्देश

PACKING, MARKING, SHIPPING AND
DOCUMENTATION
SPECIFICATIONS FOR INDIGENOUS
MATERIALS

1	10-09-2018	ISSUED FOR COMPLIANCE	DDC	DRC	ED (SCM)
0	05-12-2012	ISSUED FOR COMPLIANCE	DDC	DRC	GM (I)
Rev. No	Date	Purpose	Prepared by	Reviewed by	Approved by

Abbreviations:

CM	-	Centimeters
EIL	-	Engineers India Limited
E-way bill	-	Electronic Way Bill
Kg	-	Kilograms
FTL	-	Full Truck / Trailer Load
KGS	-	Kilograms
L.R.	-	Lorry Receipt / Goods Receipt
mm	-	Millimetre
MT	-	Metric Ton
NO. / NOS.	-	Number / Numbers
P.O.	-	Purchase Order
RCM	-	Resident Construction Manager

Document drafting Committee Members:

Shri. V.S.Krishnaswamy, Manager (SCM-Shipping)

Shri Ashish Mathur, Manager (SCM-Shipping)

Document review Committee Members:

Shri Uttam Kumar, Manager (SCM-C&P)

Shri R K Singh, Sr. G.M (SCM) & Head (Shipping)

Shri Rajeev Kumar, Sr. G.M (SCM-Inspection)

1. GENERAL

1.1 Purpose

This specification details the minimum requirements for the preservation, packing, marking, shipping and documentation of Products, materials and equipment as specified in the respective Purchase Orders or Contracts. This specification forms an integral part of the Purchase Order or Contract issued. However, whenever specific instructions are detailed in the Purchase Order and are in conflict with this specification, particular instructions mentioned in the individual Purchase Order or Contract shall prevail over this general specification.

1.2 Requirements and Conditions

The following requirements are intended as minimum requirements, and compliance to these requirements in no way absolves or relieves Supplier of any responsibility or obligation outlined in the Purchase Order. Equivalent or better packing methods may be deployed wherever supplier's own packing standards are more stringent to the requirements mentioned herein. Supplier shall submit the packing procedure or its equivalent for purchaser's approval during detailed engineering.

In all circumstances, the packing will be designed and constructed in order to support materials during transportation as well as to prevent the materials from damage due to impact, extreme climatic conditions, sun and rain. It must be ensured that the materials and equipments are delivered to the job site by sea, road or air, in good condition.

The Supplier shall, at its own cost, ensure items to be transported are carefully packed and protected in accordance with best practice, having due regard to the climatic conditions encountered during the passage, method of carriage and handling / loading / unloading processes. In addition to any of the measures detailed within this Specification, the Supplier shall apply any other measures that, in its experience, are required to safeguard the particular item. The Supplier shall obtain the approval of EIL / Owner for any variation to the packing, marking and shipping requirements outlined in this Specification.

1.3 Responsibility and liability

Supplier shall be held responsible for any damages and / or losses of all and any kind that may occur by not respecting these specifications. Owner / EIL reserves the right to reject any packing when the packing does not conform to these specifications / instructions and / or when the packing does not ensure perfect protection of the goods and materials. Supplier is responsible for the weights and dimensions declared and the marking of the packages. Supplier will be held responsible in the event goods and materials becoming useless, broken or damaged as a result of poor packing and / or stowing or due to corrosion because of insufficient or inadequate protection. All direct and indirect costs resulting thereof will be back charged to Supplier.

2. CLEANING AND PRESERVATION

2.1 Cleaning

All equipment, materials and parts shall be thoroughly cleaned inside and outside and shall be free from grease, oil, weld spatter, rust and all other foreign matter prior to preservation.

2.2 Preservation

Articles may be exposed to severe environmental or climatic conditions, moisture and dust. All materials and equipment shall be packaged suitable to prevent damage and deterioration during transportation and storage. Where damage occurs due to inadequate packaging of items, the liability for costs associated with rectification of the damage will be to the Supplier's account. All metals subject to corrosion shall be treated with a corrosion preservative suitable for the purpose intended. Products susceptible to corrosion must be packaged in a dry non-corrosive environment for the duration of shipment and storage, for a minimum of 1 year. All bright and machined parts shall be coated with a recognized rust preventative suited to the particular application concerned. All internal parts of machinery shall be treated with lubricant containing rust and oxidation inhibitors to protect equipment from any possible damage. Such lubricants shall be compatible with those which will subsequently be used in service and shall be identified by appropriate tagging. Electrical equipment and instrumentation shall be packed with a suitable desiccant. Delicate equipment such as instruments, electrical switchboards and panels etc. shall be packed for protection to eliminate the effects of vibration.

Wherever necessary, desiccant packs shall be kept to avoid excessive moisture in the packing.

3. PACKING

3.1 General

The instructions herein shall be considered as general directives and minimal requirements, which are applicable to the packing of all equipment and materials. The Supplier is responsible for the correct and adequate packing of the equipment and materials so that these equipment and materials will arrive at destination undamaged and the packing itself in such a condition that, if not otherwise required, it will be suitable for a minimum of 1 year storage.

3.2 Packaging Materials

All packaging together with packaging and protective materials shall be new, maintain its integrity and perform its intended function while being transported, handled and stored.

The quality of packing shall provide maximum protection against damage, breakage and pilferage during transport, storage and multiple handling, including handling by hoisting, lifting devices and / or forklift trucks. Material used for packaging, packing, wrapping, sealers, moisture resistant barriers and corrosion preservatives shall be of recognized brands and grades and shall conform to the best world standards.

Packaged Products showing any damage, defect or shortage resulting from improper packaging, packaging materials or packing procedure or having concealed damage or being short at the time of unpacking shall be subject to rejection and be replaced at the Supplier's cost

3.3 Packing requirements

3.3.1 Wooden Boxes and Crates

Interior support board shall be of strength to withstand multiple handling. Tops of crates shall be one piece wherever possible to avoid seepage through cracks; otherwise a top coating is required. Waterproof lining shall be used for sides, ends and top of crates, proper venting of cargo boxes containing machinery is required, as well as sufficient use

of desiccants. Crates shall be diagonally braced on all faces and suitable for hooks, slings and forklifts. Heavy items shall be secured with wood braces. Fragile items shall be cushioned. Material packed in large boxes shall be layered between plywood sheets to maintain load integrity during transit. Banding shall be used on all boxes to prevent distortion / deformation of the box.

3.3.2 Pallets

When equipment and/or materials are packed on pallets (wood or synthetic), these should be solid double deck pallets that provide adequate load support during transportation and storage (under not always ideal conditions). The pallets should have a dynamic load capacity, enough to carry the mass loaded on the pallet. Where feasible, the top surface of the pallet must be flat. The pallet design must enable safe handling by forklift, cranes etc. and storage on rough surface. Pallets shall be covered with wrapping. All corners, horizontal and vertical shall be protected with cardboard protection strips. The pallet must be tied on all sides with steel or synthetic straps.

3.4 Packaging

All equipment and materials shall be properly fixed (by bolts, clamps, supporting beams, etc.) in such a way that internal movements and / or loosening is impossible. Under the top cover (roof) depending on the case and crate length, a sufficient number of strong beams shall be placed and properly fixed in order to allow stacking of the cases and crates avoiding any compression. Equipment parts and materials which may be subject to damage by vibration and /or shock must be protected using shock-absorbing material. All equipment and materials which may be damaged by moisture shall be packed in airtight bags in which sufficient desiccant material (e.g. silica gel) is placed. All openings on the equipment must be closed with wooden / metal or plastic covers to prevent damage to the openings and interiors. Fragile and loose parts easily damageable pertaining to the equipment must be securely and properly packed in a separate case.

3.5 Waterproofing

Cases including the cover shall be internally lined with a strong type of waterproof paper or plastic foil. Equipment and materials shall always be packed in a foil (polyethylene or aluminum) for extra (double) protection against rainfall. Those foils shall be applied in such a way that they are self draining.

3.6 Hazardous cargo

The hazardous materials shall be packed in accordance with and in cognizance to the applicable rules, regulations and tariff of all Governmental Authorities and other Governing bodies. Hazardous materials shall always be packed and documented separately from any other material. It shall be the responsibility of the seller of hazardous materials to designate the materials as hazardous and to identify each material by its proper commodity name and its hazardous materials class code. Safety and emergency procedures shall be displayed outside the package. Any certificates required for transportation or for authorities to be supplied before shipment of the goods

4. GUIDELINES FOR PACKING GOODS

In subsequent paragraphs details of different types of packing for different types of goods are defined. Supplier shall make packing details / procedure based on the guidelines and submit for approval.

Chemicals in powder form, catalysts, refractories & like materials etc. shall be packed in drums only.

4.1 Pipe

All pipes 2" included and below shall be packed in crates. All pipes to be capped and ends sealed with waterproof tape. Pipes over 2" up to 6", shall be bundled and banded in bundles of uniform length. Bundling is carried out with U-IRON or traversal planks, joined with threaded connecting rods with locknuts.. Bundle weight shall not exceed 2,000 kg. All pipes are to be capped and ends sealed with waterproof tape (tape is not necessary if end caps are of the pre-shrunk or self-sealing type). Pipes larger than 6" shall be shipped as single lengths with the ends capped. End caps are to be of the recessed type to enable the use of soft faced hooks, but still completely sealing the end and also protecting the weld. All stainless steel / non-ferrous piping must be packed separately in wooden crates. Any banding of bundles is to be with the same material. The bundling and packing of pipe and instrument tubing shall enable the safe discharge of pipe on site using clamps and forklifts. All pipes shall be supported along their lengths to prevent bending / flexing during transport. During loading / unloading slings shall be applied to the center of the load as well as each end to prevent bowing.

Pipe and rigid conduit smaller than DN50 diameter shall be bundled in units not to exceed 1000 kg. Threaded and coupled pipe shall be equipped with plastic thread protectors. All material shall be segregated and shipped by generic material type to prevent cross contamination. Where wire rope or chains are used, adequate padding shall be used at points of contact with pipe. Care must be taken to prevent any chafing of pipes against each other or against the metal structures of the vehicle during transportation. Where necessary, such metal structures must be padded with planks or plastic tubes. Skids and dunnage must be used between the bundles in transit as well as in the storage of coated pipes.

4.2 Pipe Fittings, Flanges, Valves and Gaskets

All pipe fittings, flanges and valves up to 6", are to be packed in cases / crates. For items over 6", these may be fixed securely to a pallet base and enclosed in a crate, for protection. All flange faces / bevel ends shall be suitable protected with plastic caps / end protectors. Where valves have actuators attached, rigidity must be ensured for the valve and actuator. The vulnerable parts of the actuator are to be completely protected within a wooden crate. Empty spaces shall be filled with expanded PU foam to restrict movement in the crate. All stainless steel fittings, flanges and valves of all sizes, must be packed separately in wooden crates. Any strapping is to be with the same material. Gaskets are considered fragile and shall be treated as such. Individual gasket sizes shall be boxed and labeled separately.

All threaded fittings and pipes should be greased and provided with plastic caps.

4.3 Steel Structure and Plates

Structural steel sections and plates shall be strapped in bundles of convenient size and weight for handling. Rolled and shaped plates shall be provided with suitable bracing to eliminate distortion during transit, and shall be bundled in uniform lengths. Each bundle shall be marked with a metal tag, hard stamped, secured under steel wrapping. A 2000 kg limitation shall be imposed for lifts in this category unless exempted.

4.4 Itemized Equipment

Units or parts belonging to main equipment but separately packed shall be clearly marked for easy identification with the main equipment to which they relate.

All flanges, machined working surfaces and threaded parts of all equipment shall be suitably protected. All flanged connections of vessels shall be protected by metal plates correctly casketed by wooden plugs or plastic caps suitably secured in position.

Vessels shall, where possible, be packed on skid constructions and secured with adjustable steel straps. Manholes and other major openings shall be protected with cover flanges or metallic plates firmly secured. Smaller openings shall be closed with plastic plugs / caps.

All vessel internals and items not installed by Supplier at works including accessories such as small parts, bolts, nuts, gaskets, etc. shall be packed in wooden cases separately for each vessel or apparatus and marked with the same item number as the vessel / apparatus in order to protect all parts from loss or damage in transit. Internals, bolts and gaskets for service / testing operations shall be supplied with the vessels / items by Supplier and all internals shall be boxed separately and marked according to marking procedure; each item shall be supplied correctly and identified for field installation by others.

All vessels / heat exchangers or items of such construction shall be dried, thoroughly cleaned inside and be free of all dirt and loose foreign materials. The equipment shall be filled with Nitrogen. Make up arrangement for loss of Nitrogen along with a pressure gauge shall be installed.

All commissioning spare parts shall be packed separately and marked with the relevant main item number.

Pumps, compressors, rotating equipment, turbines and motors will require specific packing and preservation as per the relevant Technical Specification. For skidded equipment openings, flange faces, threaded connections, wires, valve stems, and other component parts that may be subjected to mechanical damage or corrosion shall be adequately protected. This protection shall be applied to all components, both those removed and boxed and those remaining in place on the skid assembly. Each skid shall have one box strapped to it containing a complete set of drawings together with a manual covering installation and operating instructions and other pertinent instructions required for reassembly of components that were disassembled for shipment.

4.5 Control Panels and Electrical Devices

Equipment such as control panels, instruments and electrical devices shall be packed in an interior moisture / vapor-proof barrier with silica gel or comparable desiccant. Desiccants shall be bagged to avoid dispersing in containers. The quantity of desiccant shall be calculated in accordance with the manufacturer's recommendations. Equipment must be secured to the case with bolts, blocks or straps. Adequate precautions (for example, shaft locks to prevent longitudinal / rotational movement of rotor shafts in motors) shall be included in the packaging of all equipment which has plain, ball or roller bearings so as to minimize the risk of bearing damage.

4.6 Instruments

Instruments shall be thoroughly clean, dry and free from rust and individually wrapped using polythene sheets / U foam / Thermocol sheets depending upon the items and then packed in wooden boxes. The left out spaces and top of the boxes should be filled with rubberized coir to get proper cushioning effect. Special attention shall be paid for arresting movements of their operating mechanism during transportation. Silica gel or

other approved desiccant shall be strapped inside but shall not come into contact with the paintwork.

4.7 Cables

All electric cables to be packed in new cable drums made of steel and painted with epoxy resin paint. Cable ends to be carefully protected before packing. Polythene sheet should be wrapped over the cables and sealed properly. Cable drum can be put in wooden crates for ease in handling and transportation.

4.8 Saddles, Supports, Spiders and Lifting Equipment

All items which cannot be transported without independent supports must be supplied with Shipping saddles suitable for land and / or ocean transit. Such transport saddles are to be included within the scope of supply. Supplier is to advise of any requirement for lifting beams or other specialized lifting equipment and will include provision for use of such equipment for loading purposes. The Supplier is responsible for ensuring that all modules and oversize items are adequately braced and where required, plastic wrapped suitable for transport. Modules and oversize items shall be packaged to prevent damage during transport.

4.9 Assortment Of Package / Spare Parts for Erection and Commissioning

Equipment and / or parts of different item numbers shall not be packed together in the same package. Small goods such as accessories, spare parts for erection and commissioning and special tools shall be packed separately in respective inner boxes with tags or labels attached there being clearly indicating their contents. In case such accessories, spare parts and special tools are packed in separate boxes / crates, item no. of main equipment shall be clearly mentioned in Main Shipping Mark for easy identification.

5. MARKING

5.1 General

The purpose of the marking is to identify the packages and detail the weight and dimensions to assure efficient and correct handling during transport and upon arrival at destination.

5.2 Marking Instructions & dispatch details

Packages and crates will be marked with indelible black paint. Marking must be perfectly legible. All packages shall be clearly and properly marked in English language if not otherwise specified.

The shipping marks, which will be shall be stenciled on two sides and one end in clear characters at least 5 centimeters high (where crate size permits, otherwise use optimum size for each package dimension).

The texts shall be printed by means of stamps, stencil-plates or electronically. The use of stickers is not allowed, unless securely covered by plastic. Bundles shall be marked by embossing on two metal tags bearing the shipping marks and placed on each side of the package and securely attaching them to the goods. Paint shall be used on metal surfaces.

Labels or tags to be clearly visible and shall be of a quality to remain visible and attached during transit, handling and storage for a minimum period of 12 Months.

Crates containing fragile articles must be packed with special precaution against risk of breakage and must be stenciled on all sides "FRAGILE - HANDLE WITH CARE". Where crates are not to be overturned, Supplier must show on the crates, clear and readily visible identification, to ensure they are kept in the correct position.

Packages / equipment of 2,000 kg or more must be marked with slinging points on all sides, in addition to the centre of gravity marks.

Number packages consecutively i.e. 1 of 10, 2 of 10, etc. Do not duplicate package numbers. SUPPLIER is responsible for any loss or damage caused by incorrect marking.

All cases/crates shall also be marked with the appropriate international standard graphic symbols for handling.

As a minimum, all cases/crates are to be marked clearly on all four sides with:

"HANDLE WITH CARE" "RIGHT SIDE UP" "KEEP DRY"

In the case of packages with a single gross weight totaling 2,000 kg and / or a height of more than 1m, the centre of gravity shall be clearly marked with the symbol on two adjoining sides. For all items of equipment with an eccentric centre of gravity this symbol shall be marked at the bottom, side and top of the package.

The slinging and lashing points shall be marked with a chain symbol.

When packing in cases / crates, these packages shall also have metal corners at the slinging points.

External front and rear sides of the boxes shall be planed for writing instructions. To facilitate identification, the required colour coding as per the specifications shall be carried out on each package and on corners of pipes & plates.

In case of bundles or other packages wherever marking cannot be stenciled, the same shall be embossed on metal or similar tag and wired securely at minimum two convenient points and both ends shall be protected / covered with gunny bags upto 18" (Eighteen Inches). In case of loose pipes, sticker of above markings should be pasted on inner wall corner of each pipe on both sides

Dispatch details such as consignor / consignee address, contract and case details, stacking instructions shall be written on one side of the boxes. One copy of packing slip wrapped in polyethylene bag covered with aluminum packing slip holder to be nailed on the external surface of the box. A packing list and preservation instructions shall be enclosed in a clear weatherproof plastic re-sealable envelope stapled to the box such that the receiver may determine contents without opening the container. An additional packing list is to be enclosed in a clear waterproof plastic re-sealable envelope stapled inside the container. Stapling of the envelopes shall not prevent removal of the documents.

5.3 Shipping Marks

Each package shall be marked on three sides with proper paints / indelible waterproof ink as follows:

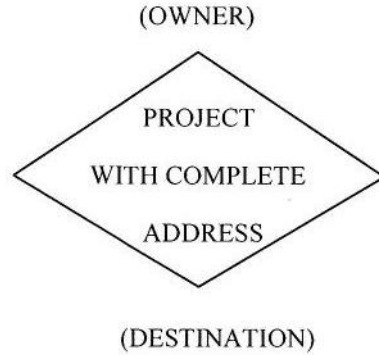

PURCHASE ORDER NO. -----

NET WEIGHT ----- KGS. GROSS WEIGHT ----- KGS.

DIMENSIONS ----- X ----- X ----- CMS

PACKAGE NOS. (SL. NO. OF PACKAGE) OF (TOTAL NO. OF PACKAGES)

TAG / ITEM NO. -----

SUPLLIER'S NAME-----

The details of the Owner / Project are defined specifically in the Purchase Order / Contract.

5.4 Storage Code

The type of storage required is required to be specified, it will be shown on each packaging in RED colour

- X Crates or packages to be stored outdoor without covers
- XX Crates or packages to be stored under tarpaulin
- XXX Crates or packages to be stored in covered or enclosed premises
- XXXX Crates or packages which must be stored in air-conditioned premises

6. SHIPMENT

Dispatch of material shall be made in accordance with the relevant terms of Purchase Order. Name of the owner, Project, location and other relevant information shall be as per the relevant annexure(s) to the Purchase Order / Contract.

Any change in mode of transport shall be resorted to only after prior approval in writing. Supplier shall ensure dispatch of equipment / materials immediately after they are

inspected and released. All consignments should be booked in the name of 'owner' and not under 'self' basis.

6.1 Dispatch By Road:

- a) The Materials shall be dispatched on Door-Delivery basis (smalls or FTL) through a registered transporter.

However, in case, the transporter is nominated by EIL / Owner, the goods shall be dispatched through the same only.

- b) The supplier shall ensure with Transport Company the delivery of materials within a reasonable transit period. A complete set of dispatch documents (Delivery Challan / Invoice / Packing List / Test Certificate / L.R. / E-way Bill number etc.) shall be sent to Head (Shipping) at EIL New Delhi and the Resident Construction Manager (RCM) at site.

6.2 Shipment By Air:

Whenever supplier is instructed by EIL/ Owner to airfreight any material, the supplier shall take prompt action for the same. Immediately after air-shipment is effected, the vendor shall intimate by e-mail, the details of Airway Bill number and date, the flight No., Number of packages etc. to Head-Shipping, EIL New Delhi and Resident Construction Manager at EIL (Site).

6.3 Destination:

The consignments should be dispatched to the Consignee / Address as detailed in the Purchase Order.

6.4 Advance Information:

Immediately after a shipment is made supplier shall intimate Underwriter, Head (Shipping) and RCM vide mail regarding particulars of materials, value, Purchase Order No., date of dispatch, L.R. number, E-way Bill No., truck no., name of Transport Company.

6.5 Transmission of Dispatch Documents :

Supplier shall, within 48 hrs. of the dispatch of the materials depending upon the payment terms of the Purchase Order, either negotiate through Owner's / EIL's Bankers or forward directly, by Courier the complete set of dispatch Documents (as detailed in Purchase Order) to Owner / EIL. The supplier shall be responsible for any delay in clearance of the consignment at destination and consequent wharfage / demurrage, if any, due to delay in transmittal of the required documents.

7. TRANSIT RISK INSURANCE

All equipments / materials will be insured for transit risk by (Owners) unless otherwise specified. The insurance cover will be provided from warehouse-to-warehouse.

Tender Inviting Authority: GM (SCM), ENGINEERS INDIA LIMITED, GURUGRAM-122001, HARYANA

Name of Work / Enquiry No.: VALVES-GATE, GLOBE & CHECK (LT & CRYO)-FORGED FOR PDH PP PLANT WITH ETHANE AND PROPANE HANDLING FACILITIES PROJECT AT DAHEJ, GUJARAT OF M/s PLL / RFQ No. : JP/B862-000-WB-MR-3233/82

Preamble to Price Schedule (BoQ):

Preamble to Price Schedule (BoQ):

- i) This BOQ sheet "BoQ1" shall be filled by the BIDDER.
- ii) Currency of Quote shall be in INR only.
- iii) Supply Price shall be on FOT Despatch point basis at Column No. "6".
- iv) "SUPPLY PRICE" should be inclusive of all all taxes & duties (except GST) applicable to the bidder but shall exclude Road Transportation charges (which is sought separately). Any other charges indicated as applicable "EXTRA" elsewhere in the bid shall be considered "Included" in the quoted "SUPPLY PRICE". Bidder to note that no other charges except those quoted in the Price Schedule (BoQ) shall be considered for evaluation/ordering.
- v) Bidders shall quote Road Transportation charges till Site excluding GST in terms of Percentage of FOT Despatch Point Price at Column No. "8"
- vi) Bidders are advised not to tamper with this BoQ format.
- vii) Evaluation & Ordering shall be done on ITEMWISE basis. For details of each item, please refer the MR.
- ix) Bidder to submit the details of built in CIF Value as per the format enclosed as " CIF Format" (if applicable/if any)
- x) In case of any discrepancy in the Item Description/Tag No./ Qty./Block No. specified in this Price Schedule vis-à-vis the corresponding details in MR, the Item Description/Tag No./ Qty./Block No. specified as per MR shall prevail.

Name of the Bidder/ Bidding Firm / Company :	
--	--

PRICE SCHEDULE

(This BOQ template must not be modified/replaced by the bidder and the same should be uploaded after filling the relevant columns, else the bidder is liable to be rejected for this tender. Bidders are allowed to enter the Bidder Name and Values only)

Sl. No.	ITEM DESCRIPTION AS PER MR Supply of VALVES-GATE, GLOBE & CHECK (LT & CRYO)-FORGED	QTY.	UNIT	Quoted Currency (in INR only)	UNIT SUPPLY PRICE ON FOT DESPATCH POINT BASIS EXCL. GST AS PER MR SL. NO. 01.00 (in INR) (To be filled by bidder)	TOTAL SUPPLY PRICE ON FOT DESPATCH POINT BASIS EXCL. GST AS PER MR SL. NO. 01.00 (in INR)	ROAD TRANSPORTATION CHARGES TILL SITE TO BE QUOTED IN TERMS OF PERCENTAGE OF FOT DESPATCH POINT PRICE (in %age) (Excl. GST) (To be filled by bidder)
1	2	3	4	5	6	7	8
1.00	ITEM SR NO : 1 as per MR	13	NOS	INR		0.00	
2.00	ITEM SR NO : 2 as per MR	286	NOS	INR		0.00	
3.00	ITEM SR NO : 3 as per MR	9	NOS	INR		0.00	
4.00	ITEM SR NO : 4 as per MR	5	NOS	INR		0.00	
5.00	ITEM SR NO : 5 as per MR	10	NOS	INR		0.00	
6.00	ITEM SR NO : 6 as per MR	54	NOS	INR		0.00	
7.00	ITEM SR NO : 7 as per MR	5	NOS	INR		0.00	
8.00	ITEM SR NO : 8 as per MR	19	NOS	INR		0.00	
9.00	ITEM SR NO : 9 as per MR	107	NOS	INR		0.00	
10.00	ITEM SR NO : 10 as per MR	5	NOS	INR		0.00	
11.00	ITEM SR NO : 11 as per MR	6	NOS	INR		0.00	
12.00	ITEM SR NO : 12 as per MR	5	NOS	INR		0.00	
13.00	ITEM SR NO : 13 as per MR	21	NOS	INR		0.00	
14.00	ITEM SR NO : 14 as per MR	50	NOS	INR		0.00	
15.00	ITEM SR NO : 15 as per MR	5	NOS	INR		0.00	

Tender Inviting Authority: GM (SCM), ENGINEERS INDIA LIMITED, GURUGRAM-122001, HARYANA

Name of Work / Enquiry No.: VALVES-GATE, GLOBE & CHECK (LT & CRYO)-FORGED FOR PDH PP PLANT WITH ETHANE AND PROPANE HANDLING FACILITIES PROJECT AT DAHEJ, GUJARAT OF M/s PLL / RFQ No. : JP/B862-000-WB-MR-3233/82

Preamble to Price Schedule (BoQ):

Preamble to Price Schedule (BoQ):

- i) This BOQ sheet "BoQ1" shall be filled by the BIDDER.
- ii) Currency of Quote shall be in INR only.
- iii) Supply Price shall be on FOT Despatch point basis at Column No. "6".
- iv) "SUPPLY PRICE" should be inclusive of all all taxes & duties (except GST) applicable to the bidder but shall exclude Road Transportation charges (which is sought separately). Any other charges indicated as applicable "EXTRA" elsewhere in the bid shall be considered "Included" in the quoted "SUPPLY PRICE". Bidder to note that no other charges except those quoted in the Price Schedule (BoQ) shall be considered for evaluation/ordering.
- v) Bidders shall quote Road Transportation charges till Site excluding GST in terms of Percentage of FOT Despatch Point Price at Column No. "8"
- vi) Bidders are advised not to tamper with this BoQ format.
- vii) Evaluation & Ordering shall be done on ITEMWISE basis. For details of each item, please refer the MR.
- ix) Bidder to submit the details of built in CIF Value as per the format enclosed as " CIF Format" (if applicable/if any)
- x) In case of any discrepancy in the Item Description/Tag No./ Qty./Block No. specified in this Price Schedule vis-à-vis the corresponding details in MR, the Item Description/Tag No./ Qty./Block No. specified as per MR shall prevail.

Name of the Bidder/ Bidding Firm / Company :	
---	--

PRICE SCHEDULE

(This BOQ template must not be modified/replaced by the bidder and the same should be uploaded after filling the relevant columns, else the bidder is liable to be rejected for this tender. Bidders are allowed to enter the Bidder Name and Values only)

Sl. No.	ITEM DESCRIPTION AS PER MR Supply of VALVES-GATE, GLOBE & CHECK (LT & CRYO)-FORGED	QTY.	UNIT	Quoted Currency <i>(in INR only)</i>	UNIT SUPPLY PRICE ON FOT DESPATCH POINT BASIS EXCL. GST AS PER MR SL. NO. 01.00 <i>(in INR)</i> <i>(To be filled by bidder)</i>	TOTAL SUPPLY PRICE ON FOT DESPATCH POINT BASIS EXCL. GST AS PER MR SL. NO. 01.00 <i>(in INR)</i>	ROAD TRANSPORTATION CHARGES TILL SITE TO BE QUOTED IN TERMS OF PERCENTAGE OF FOT DESPATCH POINT PRICE <i>(in %age)</i> <i>(Excl. GST)</i> <i>(To be filled by bidder)</i>
1	2	3	4	5	6	7	8
16.00	ITEM SR NO : 16 as per MR	16	NOS	INR		0.00	
17.00	ITEM SR NO : 17 as per MR	12	NOS	INR		0.00	
18.00	ITEM SR NO : 18 as per MR	14	NOS	INR		0.00	
19.00	ITEM SR NO : 19 as per MR	21	NOS	INR		0.00	
20.00	ITEM SR NO : 20 as per MR	20	NOS	INR		0.00	
21.00	ITEM SR NO : 21 as per MR	21	NOS	INR		0.00	
22.00	ITEM SR NO : 22 as per MR	76	NOS	INR		0.00	
23.00	ITEM SR NO : 23 as per MR	5	NOS	INR		0.00	
24.00	ITEM SR NO : 24 as per MR	116	NOS	INR		0.00	
25.00	ITEM SR NO : 25 as per MR	155	NOS	INR		0.00	
26.00	ITEM SR NO : 26 as per MR	5	NOS	INR		0.00	
27.00	ITEM SR NO : 27 as per MR	5	NOS	INR		0.00	
28.00	ITEM SR NO : 28 as per MR	9	NOS	INR		0.00	
29.00	ITEM SR NO : 29 as per MR	13	NOS	INR		0.00	
30.00	ITEM SR NO : 30 as per MR	28	NOS	INR		0.00	
31.00	ITEM SR NO : 31 as per MR	5	NOS	INR		0.00	

DETAILS OF BUILT-IN-CIF VALUE OF IMPORT CONTENT (RAW MATERIALS)

Name of Work / Enquiry No.: VALVES-GATE, GLOBE & CHECK (LT & CRYO)-FORGED FOR PDH PP PLANT WITH ETHANE AND PROPANE HANDLING FACILITIES PROJECT AT DAHEJ, GUJARAT OF M/s PLL / RFQ No. : JP/B862-000-WB-MR-3233/82

FORMAT CIF/CD

NAME OF BIDDER:

OFFER NO.

ITEMWISE BREAK-UP OF BUILT-IN-CIF VALUE OF IMPORT CONTENT, ITEM DETAILS OF IMPORT CONTENT AND RATES OF IMPORTS DUTY CONSIDERED AND INCLUDED IN QUOTED FOT DESPATCH POINT PRICES UNDER PRICE SCHEDULE BOQ1

NAME OF BIDDER:

S no.	DESCRIPTION			Total MR item wise CIF value of Import Content included in quoted supply prices of MR item (In Rs)		DETAILS OF CUSTOMER DUTY INCLUDED IN QUOTED SUPPLY PRICES OF MR ITEM		
	For Item S. No. as per MR	Description of Imported items	Qty.	In Figures	In Words	CUSTOM TARIFF No.	BASIC CUSTOMS DUTY (%)	SOCIAL WELFARE SURCHARGE ON CUSTOM DUTY (%)
1								
2								
3								
4								
5								
6								
7								
8								

Note:

1	Bidder has to ensure that currency quoted in this format shall be INR only.
2	Un-priced copy shall be furnished exactly duplicate of price schedule duly indicating rate of duties except for CIF value.
3	The CIF Value(s) indicated by the vendor shall be deemed to be the maximum value(s) for the purpose of payment of variation in Basic Custom Duty and Customs Social Welfare Surcharge.
4	Bidder to consider input tax credit of IGST available at their end (in case of import of raw materials / component) in their prices; hence bidder shall not indicate GST in above table.



BIDDING DOCUMENT NO. JP/B862-000-WB-MR-3233/82

**BIDDING DOCUMENT
FOR
VALVES-GATE, GLOBE & CHECK (LT & CRYO)-FORGED
FOR
PDH PP PLANT WITH ETHANE AND PROPANE HANDLING
FACILITIES PROJECT AT DAHEJ, GUJARAT**

TECHNICAL SECTION

Prepared & Issued by:

**इंजीनियर्स
इंडिया लिमिटेड**  **ENGINEERS
INDIA LIMITED**
(भारत सरकार का उपक्रम) (A Govt. of India Undertaking)

MATERIAL REQUISITION(TOP SHEET)

ITEM : VALVES-GATE, GLOBE & CHECK (LT & CRYO)-FORGED

Issue Status (Fill 1 or 2 from below in this bracket) []

- 1. -> Entire Requisition Issued
- 2. -> Only Revised Pages are Issued

MR Category : I

PDD ITEMCODE : 50AE,50BE,50CE

DOCUMENT NUMBER

(Always quote this document number given below as reference)

B862	000	WB	MR	3233	A	17-04-2026	16/43
JOB NO.	UNIT / AREA	COST CENTRE	DOC CODE	SR. NO	REV	DATE	ORIGINATING DIVN./DEPT

VENDOR CODE	VENDOR NAME

Material to be delivered at (job site) PETRONET LNG LIMITED,DAHEJ, GUJARAT within the delivery period specified in the "Request For Quotation"(RFQ).

Notes :

1. This page is a record of all the Revisions of this Requisition.
2. The nature of the Revision is briefly stated in the "Details" column below, the Requisition in its entirety shall be considered for contractual purposes.
3. When a Requisition is revised, only the revised pages may be issued.
4. When revised pages only are issued, the revised pages shall form part of the original Requisition. The original requisition alongwith the revised pages shall be considered in its entirety for contractual purposes.
5. Vendors are required to quote strictly as per technical specifications / notes stipulated in the material requisition. The offers with deviations are likely to be summarily rejected.

REV	DATE	BY	CHK	APPD.	DETAILS
A	17-04-2026	AG	AB	AB/PS	ISSUED FOR BIDS

This is a system generated approved document and does not require Signature

This drawing and design it covers are property of ENGINEERS INDIA LIMITED. They are merely loaned on the borrower's express agreement that it will not reproduce, copied, exhibited nor used except in the limited way and private use permitted by written consent given by the lender to the borrower for the intended use.EIL-1641-515 Rev.0 A4-21(0x297 EIL - 588 A - 216 x 279



ENGINEERS INDIA LIMITED
NEW DELHI

Project : PDH - PP PLANT
Client : PETRONET LNG LIMITED

Requisition No.
B862-000-WB-MR-3233

Rev
A

LIST OF ATTACHMENT

SR. NO.	DOCUMENT TITLE	DOCUMENT NO.	REVISION	
			NO.	DATE
1	ADDITIONAL TECHNICAL REQUIREMENTS FOR VALVES-GATE, GLOBE AND CHECK (LT & CRYO) -FORGED	B862-000-16-43-ATR- 3233	A	16-APR-2026
2	VALVE MATERIAL SPECIFICATION FOR MR NO. B862-000-WB-MR-3233	B862-000-6-44-0006- 3233	A	16-APR-2026
3	TECHNICAL NOTES FOR VALVES	6-44-0052	9	09-JUL-2024
4	INSPECTION AND TEST PLAN FOR VALVES	6-81-0004	7	08-MAY-2023
5	STANDARD SPECIFICATION FOR POSITIVE MATERIAL IDENTIFICATION (PMI) AT SUPPLIER'S WORK	6-81-0001	4	23-DEC-2021
6	SPECIFICATION FOR QUALITY MANAGEMENT SYSTEM REQUIREMENTS FROM BIDDERS	6-78-0001	2	12-JUN-2020
7	SPECIFICATION FOR DOCUMENTATION REQUIREMENTS FROM SUPPLIERS	6-78-0003	2	12-JUN-2020

This drawing and design it covers are property of ENGINEERS INDIA LIMITED. They are merely loaned on the borrower's express agreement that it will not reproduce, copied, exhibited nor used except in the limited way and private use permitted by written consent given by the lender to the borrower for the intended use.EIL-1641-515 Rev.0 A-4-21(0x297 EIL - 588 A - 216 x 279



ENGINEERS INDIA LIMITED
NEW DELHI

Project : PDH - PP PLANT

Client : PETRONET LNG LIMITED

Requisition No.

B862-000-WB-MR-3233

Page 2 of 4

Rev

A

MR ATTACHMENT

SR.NO.	ITEMCODE	DETAIL DESCRIPTION	QTY.	U.RATE	TOT.VALUE	CDD
Item Description : VLV.GATE, SHEET 51003, LT						
1	51003ZZZ504ZZZZZZ	0.5 INCH	13 NOS			
2	51003ZZZ505ZZZZZZ	0.75 INCH	286 NOS			
3	51003ZZZ506ZZZZZZ	1.0 INCH	9 NOS			
4	51003ZZZ508ZZZZZZ	1.5 INCH	5 NOS			
Item Description : VLV.GATE, SHEET 510AN, LTH2						
5	510ANZZZJ04ZZZZZZ	0.5 INCH	10 NOS			
6	510ANZZZJ05ZZZZZZ	0.75 INCH	54 NOS			
7	510ANZZZJ08ZZZZZZ	1.5 INCH	5 NOS			
Item Description : VLV.GATE, SHEET 510EQ, CRYO						
8	510EQZZZ404ZZZZZZ	0.5 INCH	19 NOS			
9	510EQZZZ405ZZZZZZ	0.75 INCH	107 NOS			
10	510EQZZZ408ZZZZZZ	1.5 INCH	5 NOS			
Item Description : VLV.GATE, SHEET 511EQ, CRYO						
11	511EQZZZ405ZZZZZZ	0.75 INCH	6 NOS			
Item Description : VLV.GATE, SHEET 51901, CRYO						
12	51901ZZZ405ZZZZZZ	0.75 INCH	5 NOS			
Item Description : VLV.GLOBE, SHEET 52003, LT						
13	52003ZZZ504ZZZZZZ	0.5 INCH	21 NOS			
14	52003ZZZ505ZZZZZZ	0.75 INCH	50 NOS			
15	52003ZZZ506ZZZZZZ	1.0 INCH	5 NOS			
Item Description : VLV.GLOBE, SHEET 520AN, LTH2						
16	520ANZZZJ04ZZZZZZ	0.5 INCH	16 NOS			
17	520ANZZZJ05ZZZZZZ	0.75 INCH	12 NOS			
18	520ANZZZJ06ZZZZZZ	1.0 INCH	14 NOS			
Item Description : VLV.GLOBE, SHEET 520EQ, CRYO						
19	520EQZZZ404ZZZZZZ	0.5 INCH	21 NOS			
20	520EQZZZ405ZZZZZZ	0.75 INCH	20 NOS			
21	520EQZZZ4062ZZZZZZ	1.0 INCH, LOCK CLOSED	21 NOS			
22	520EQZZZ406ZZZZZZ	1.0 INCH	76 NOS			
23	520EQZZZ408ZZZZZZ	1.5 INCH	5 NOS			

This drawing and design it covers are property of ENGINEERS INDIA LIMITED. They are merely loaned on the borrower's express agreement that it will not reproduce, copied, exhibited nor used except in the limited way and private use permitted by written consent given by the lender to the borrower for the intended use. EIL-1641-515 Rev.0 A4-210x297 EIL - 588 A - 216 x 279



ENGINEERS INDIA LIMITED
NEW DELHI

Project : PDH - PP PLANT

Client : PETRONET LNG LIMITED

Requisition No.

B862-000-WB-MR-3233

Page 3 of 4

Rev

A

MR ATTACHMENT

SR.NO.	ITEMCODE	DETAIL DESCRIPTION	QTY.	U.RATE	TOT.VALUE	CDD
Item Description : VLV.GLOBE, SHEET 521EQ, CRYO						
24	521EQZZZ4062ZZZZZ	1.0 INCH, LOCK CLOSED	116 NOS			
Item Description : VLV.CHECK, SHEET 53003, LT						
25	53003ZZZ505ZZZZZZ	0.75 INCH	155 NOS			
26	53003ZZZ506ZZZZZZ	1.0 INCH	5 NOS			
27	53003ZZZ508ZZZZZZ	1.5 INCH	5 NOS			
Item Description : VLV.CHECK, SHEET 530AN, LTH2						
28	530ANZZZJ05ZZZZZZ	0.75 INCH	9 NOS			
Item Description : VLV.CHECK, SHEET 530EQ, CRYO						
29	530EQZZZ405ZZZZZZ	0.75 INCH	13 NOS			
Item Description : VLV.CHECK, SHEET 531EQ, CRYO						
30	531EQZZZ406ZZZZZZ	1.0 INCH	28 NOS			
Item Description : VLV.CHECK, SHEET 53901, CRYO						
31	53901ZZZ404ZZZZZZ	0.5 INCH	5 NOS			

This drawing and design it covers are property of ENGINEERS INDIA LIMITED. They are merely loaned on the borrower's express agreement that it will not reproduce, copied, exhibited nor used except in the limited way and private use permitted by written consent given by the lender to the borrower for the intended use. EIL-1641-515 Rev.0 A-4-21(0x297 EIL - 588 A - 216 x 279



ENGINEERS INDIA LIMITED
NEW DELHI

Project : PDH - PP PLANT

Client : PETRONET LNG LIMITED

Requisition No.

B862-000-WB-MR-3233

Page 4 of 4

Rev

A

**ADDITIONAL TECHNICAL
REQUIREMENTS
FOR
VALVES-GATE, GLOBE & CHECK (LTCS & CRYO)-
FORGED
(MR No. B862-000-WB-MR-3233)**

PROJECT : PDH-PP PLANT

OWNER : PETRONET LNG LIMITED

PMC : ENGINEERS INDIA LTD.

JOB NO. : B862

A	16.04.2026	ISSUED FOR BIDS	AG	AB	AB/PPSW
Rev. No	Date	Purpose	Prepared by	Checked by	Approved by

ADDITIONAL TECHNICAL REQUIREMENTS
FOR VALVES- GATE, GLOBE & CHECK (LTCS & CRYO)-FORGED

1. Bidder to note that no correspondence shall be entered into or entertained after the bid submission.
2. Bidder shall furnish quotations only for those items, for which he can supply strictly as per MR specifications and for which he is approved by EIL/Owner.
3. No technical details of any nature shall be included in the offer. If the offer contains any technical deviation or clarification or stipulates any technical specifications (even if in line with the MR requirements), the offer shall be summarily rejected. Bidder to note that the MOU entered with EIL for any of the item in the requisition is NOT APPLICABLE.
4. The submission of price by bidder shall be construed to mean that he has confirmed compliance with all technical specifications of the corresponding item(s).
5. Bidder shall ensure compliance to all the specifications/documents as per "List of Attachment" attached with the Material Requisition-B862-000-WB-MR-3233.
6. Valves specified as LO (Lock Open)/ LC (Lock Closed) shall be supplied with arrangement suitable for locking in open as well as in closed position. Lock is included in vendor's scope. Lock Open/ Lock Closed arrangement with chain is not acceptable.
7. Bidder shall ensure/ certify the suitability of all items for the intended service/process conditions as per respective VMS Sheets (B862-6-44-0006-3233).
8. Refer Clause 7.4 of Technical notes for valves (6-44-0052), in addition to the services mentioned in this clause; the valves under "LT" shall be painted in Sea Green stripes and valves under "LTH2" shall be painted in Light Green stripes.
9. Items specified with specialty "LTH2", shall comply with the requirement of "LTCS" for LTCS body valves, and "Cryo" for SS Body Valves alongwith "Special Requirements for Hydrogen service" requirements as specified in the Technical Notes in the MR.
10. Valves with specialty "LT" shall be impact tested at a temperature of -48°C.
11. For all LT/CRYO Valves, leakage rate of the valves shall be as per BS 6364.
12. Bidder to note that where ever only API 602 is mentioned, it shall be read as "API 602/ISO 15761".
13. Bidder to note that where ever only BS 6364 is mentioned, it shall be read as "BS 6364/BS EN ISO28921-1".

14. For all LT & CRYO GATE Valves, following requirements shall be complied.

- Pressure relief shall be achieved by the use of a relief hole, located so as to relieve excess cavity pressure to the upstream side of the valve when the valve is closed.
- Flow direction shall be clearly indicated on all valves.

15. Bidder to note that the quantity may be increased or decreased by 25% before ordering. Final quantity shall be as per Purchase requisition.

16. In case of any conflict amongst documents attached with the MR, the most stringent shall govern and Owner's / EIL decision shall be final in this regard.

Client : PETRONET LNG LIMITED		Dept. / Sect : 16/43		
Project : PDH - PP PLANT				
Location : DAHEJ, GUJARAT		Tag No : 51003		Sheet No. 1 of 1
GATE VALVE SPECIFICATION			MANUF'S OFFER	
TAG NO. : 51003			STANDARD :	
RATING : 800			MFGRS CAT/FIG :	
STANDARD : API 602/ ISO 15761			(For category -II MRs only)	
SIZE RANGE : 0.50 " TO 1.50 "			RATING :	
ENDS : SW 3000 TO B-16.11			ENDS :	
PIPING CLASS : A40A,A42A,A4A,B40A,B42A,B4A,D4A				
DESCRIPTION	CONSTRUCTION	MATERIAL	CONSTRUCTION	MATERIAL
BODY	FORGED	ASTM A 350 GR.LF2 CL.1		
BONNET	BOLTED	ASTM A 350 GR.LF2 CL.1		
STEM	RISING	SS316 (NO CASTING)		
WEDGE DISC	SOLID	STELLITED		
BODY SEAT RING	RENEWABLE	STELLITED		
STEM PACKING	RENEWABLE WITH VALVE OPEN ON STREAM	CORROSION INHIBITED DIE FORMED FLEXIBLE GRAPHITE WITH BRAIDED ANTI EXTRUSION RINGS		
HAND WHEEL	NON RISING	MALLEABLE IRON/CAST ST/FAB.ST/DUCT. IRON		
BONNET BOLTS		ASTM A320 GR L7		
BONNET NUTS		ASTM A194 GR 4/GR 7		
BONNET GASKET		SP WND SS316 - GRAFOIL FILLER		
SPECIAL SERVICE CONDITIONS	LT	UPTO -45 DEG. C.		
BACK SEAT & SHOULDER	INTEGRAL			
OTHERS	O.S & Y.			
HYDROSTATIC TEST PRESSURE	BODY : 2975 PSIG.	SEAT : 2175 PSIG		
TEST PRESSURE WITH AIR	80 PSIG			

NOTES

- 1 THIS VALVE SPEC SHEET SHALL BE READ IN CONJUNCTION WITH TECHNICAL NOTES FOR VALVES, 6-44-0052.
- 2 ONLY IN THE CASE OF CATEGORY - II MRs,BIDDER SHALL CLEARLY WRITE ALL/ ANY DEVIATION AGAINST EACH PART/ MATERIAL OF VALVE IN THE SPACE PROVIDED FOR AND WHEREVER BIDDER AGREES WITH EIL'S SPEC BIDDER SHALL INDICATE "AGREED".
- 3 NO CUTTING/ OVERWRITING BY BIDDER ON EIL'S SPEC IS ALLOWED.
- 4 TESTING SHALL BE AS PER BS-6364 ALSO.
- 5 VALVES SHALL BE PROVIDED WITH EXTENDED BONNET AS PER BS 6364 (NON COLD BOX APPLICATION).
- 6 VALVES TO COMPLY WITH DESIGN REQUIREMENTS OF BS-6364 ALSO.
- 7 VALVES AS PER API-602 AND TESTING AS PER API-598 & BS-6364 ARE ALSO ACCEPTABLE.

SIGNATURE
&
SEAL
OF
MANUFACTURER

SHEET REV NO.	2	3	4	5	6	7
DATE	2-Jan-1995	14-Dec-2000	28-May-2001	30-Jun-2009	26-Apr-2018	9-Dec-2019

51003

Client : PETRONET LNG LIMITED		Dept. / Sect : 16/43		
Project : PDH - PP PLANT				
Location : DAHEJ, GUJARAT		Tag No : 510AN		Sheet No. 1 of 1
GATE VALVE SPECIFICATION			MANUF'S OFFER	
TAG NO.: 510AN RATING: 800 STANDARD: API 602/ ISO 15761			STANDARD:	
SIZE RANGE: 0.50 " TO 1.50 " ENDS: SW 3000 TO B-16.11			MFGRS CAT/FIG:	
PIPING CLASS: B54K,D54K			(For category -II MRs only)	
			RATING: ENDS:	
DESCRIPTION	CONSTRUCTION	MATERIAL	CONSTRUCTION	MATERIAL
BODY	FORGED	ASTM A 182 GR.F316		
BONNET	BOLTED	ASTM A 182 GR.F316		
STEM	RISING	SS 316; (NO CASTING)		
WEDGE DISC	SOLID	STELLITED		
BODY SEAT RING	RENEWABLE	STELLITED		
STEM PACKING	RENEWABLE WITH VALVE OPEN ON STREAM	CORROSION INHIBITED DIE FORMED FLEXIBLE GRAPHITE WITH BRAIDED ANTI EXTRUSION RINGS		
HAND WHEEL	NON RISING	MALLEABLE IRON/CAST ST/FAB.ST/DUCT. IRON		
BONNET BOLTS		ASTM A320 GR B8 CL.2 (IMPACT TESTED)		
BONNET NUTS		ASTM A194 GR.8 (IMPACT TESTED)		
BONNET GASKET		SP WND SS316-GRAFOIL FILLER		
SPECIAL SERVICE CONDITIONS	CRYO + H2	MIN TEMP -196 DEG C.		
BACK SEAT & SHOULDER	INTEGRAL			
OTHERS	O.S & Y.			
HYDROSTATIC TEST PRESSURE	BODY : 2900 PSIG	SEAT : 2125 PSIG		
TEST PRESSURE WITH AIR	80 PSIG			

NOTES

- THIS VALVE SPEC SHEET SHALL BE READ IN CONJUNCTION WITH TECHNICAL NOTES FOR VALVES, 6-44-0052.
- ONLY IN THE CASE OF CATEGORY - II MRs,BIDDER SHALL CLEARLY WRITE ALL/ ANY DEVIATION AGAINST EACH PART/ MATERIAL OF VALVE IN THE SPACE PROVIDED FOR AND WHEREVER BIDDER AGREES WITH EIL'S SPEC BIDDER SHALL INDICATE "AGREED".
- NO CUTTING/ OVERWRITING BY BIDDER ON EIL'S SPEC IS ALLOWED.
- TESTING SHALL BE AS PER BS 6364/ BS EN ISO 28921-1 ALSO.
- VALVE SHALL BE PROVIDED WITH EXTENDED BONNET AS PER BS 6364/ BS EN ISO 28921-1 (NON COLD BOX APPLICATION).
- VENDOR SHALL CERTIFY SUITABILITY OF THE VALVE FOR INTENDED SERVICE CONDITIONS.
- VALVES TO COMPLY WITH DESIGN REQUIREMENTS OF BS-6364/ BS EN ISO 28921-1 ALSO.
- VALVES AS PER API-602 AND TESTING AS PER API-598 & BS-6364/ BS EN ISO 28921-1 ARE ALSO ACCEPTABLE.
- VALVES SHALL MEET THE REQUIREMENTS FOR HYDROGEN SERVICE AS SPECIFIED IN 'TECHNICAL NOTES FOR VALVES'.

SIGNATURE
&
SEAL
OF
MANUFACTURER

SHEET REV NO.	0
DATE	10-Jul-2025

510AN

Client : PETRONET LNG LIMITED		Dept. / Sect : 16/43		
Project : PDH - PP PLANT				
Location : DAHEJ, GUJARAT		Tag No : 510EQ		Sheet No. 1 of 1
GATE VALVE SPECIFICATION			MANUF'S OFFER	
TAG NO.: 510EQ RATING: 800 STANDARD: API-602			STANDARD:	
SIZE RANGE: 0.50 " TO 1.50 " ENDS: SW 3000 TO B-16.11			MFGRS CAT/FIG:	
PIPING CLASS: A44K,B44K,D44K			(For category -II MRs only)	
			RATING: ENDS:	
DESCRIPTION	CONSTRUCTION	MATERIAL	CONSTRUCTION	MATERIAL
BODY	FORGED	ASTM A 182 GR.F316		
BONNET	BOLTED	ASTM A 182 GR.F316		
STEM	RISING	SS 316; (NO CASTING)		
WEDGE DISC	SOLID	STELLITED		
BODY SEAT RING	RENEWABLE	STELLITED		
STEM PACKING	RENEWABLE WITH VALVE OPEN ON STREAM	CORROSION INHIBITED DIE FORMED FLEXIBLE GRAPHITE WITH BRAIDED ANTI EXTRUSION RINGS		
HAND WHEEL	NON RISING	MALLEABLE IRON/CAST ST/FAB.ST/DUCT. IRON		
BONNET BOLTS		ASTM A320 GR B8 CL.2 (IMPACT TESTED)		
BONNET NUTS		ASTM A194 GR.8 (IMPACT TESTED)		
BONNET GASKET		SP WND SS316-GRAFOIL FILLER		
SPECIAL SERVICE CONDITIONS	CRYO	MIN TEMP -196 DEG C.		
BACK SEAT & SHOULDER	INTEGRAL			
OTHERS	O.S & Y.			
HYDROSTATIC TEST PRESSURE	BODY : 2900 PSIG	SEAT : 2125 PSIG		
TEST PRESSURE WITH AIR	80 PSIG			

NOTES

- THIS VALVE SPEC SHEET SHALL BE READ IN CONJUNCTION WITH TECHNICAL NOTES FOR VALVES, 6-44-0052.
- ONLY IN THE CASE OF CATEGORY - II MRs,BIDDER SHALL CLEARLY WRITE ALL/ ANY DEVIATION AGAINST EACH PART/ MATERIAL OF VALVE IN THE SPACE PROVIDED FOR AND WHEREVER BIDDER AGREES WITH EIL'S SPEC BIDDER SHALL INDICATE "AGREED".
- NO CUTTING/ OVERWRITING BY BIDDER ON EIL'S SPEC IS ALLOWED.
- TESTING SHALL BE AS PER BS 6364/ BS EN ISO 28921-1 ALSO.
- VALVE SHALL BE PROVIDED WITH EXTENDED BONNET AS PER BS 6364/ BS EN ISO 28921-1 (NON COLD BOX APPLICATION).
- VENDOR SHALL CERTIFY SUITABILITY OF THE VALVE FOR INTENDED SERVICE CONDITIONS.
- VALVES TO COMPLY WITH DESIGN REQUIREMENTS OF BS-6364/ BS EN ISO 28921-1 ALSO.
- VALVES AS PER API-602 AND TESTING AS PER API-598 & BS-6364/ BS EN ISO 28921-1 ARE ALSO ACCEPTABLE.
- FLUID HANDLED : LIQUIFIED NATURAL GAS, NATURAL GAS, FLARE GAS, FUEL GAS (CRYOGENIC SERVICE)

SIGNATURE
&
SEAL
OF
MANUFACTURER

SHEET REV NO.	0	1
DATE	8-Jul-2025	16-Apr-2026

510EQ

Client : PETRONET LNG LIMITED		Dept. / Sect : 16/43		
Project : PDH - PP PLANT				
Location : DAHEJ, GUJARAT		Tag No : 511EQ		Sheet No. 1 of 1
GATE VALVE SPECIFICATION			MANUF'S OFFER	
TAG NO.: 511EQ RATING: 1500 STANDARD: API-602			STANDARD:	
SIZE RANGE: 0.50 " TO 1.50 " ENDS: BW TO B-16.25			MFGRS CAT/FIG:	
PIPING CLASS: E44K			(For category -II MRs only)	
			RATING: ENDS:	
DESCRIPTION	CONSTRUCTION	MATERIAL	CONSTRUCTION	MATERIAL
BODY	FORGED	ASTM A 182 GR.F316		
BONNET	WELDED/THD & SEAL WELDED	ASTM A 182 GR.F316		
STEM	RISING	SS 316; (NO CASTING)		
WEDGE DISC	SOLID	STELLITED		
BODY SEAT RING	RENEWABLE	STELLITED		
STEM PACKING	RENEWABLE WITH VALVE OPEN ON STREAM	CORROSION INHIBITED DIE FORMED FLEXIBLE GRAPHITE WITH BRAIDED ANTI EXTRUSION RINGS		
HAND WHEEL	NON RISING	MALLEABLE IRON/CAST ST/FAB.ST/DUCT. IRON		
BOLTS		ASTM A320 GR B8 CL.2 (IMPACT TESTED)		
NUTS		ASTM A194 GR.8 (IMPACT TESTED)		
SPECIAL SERVICE CONDITIONS	CRYO	MIN TEMP -196 DEG C.		
BACK SEAT & SHOULDER	INTEGRAL			
OTHERS	O.S & Y.			
HYDROSTATIC TEST PRESSURE	BODY : 5400 PSIG	SEAT : 3975 PSIG		
TEST PRESSURE WITH AIR	80 PSIG			

NOTES

- THIS VALVE SPEC SHEET SHALL BE READ IN CONJUNCTION WITH TECHNICAL NOTES FOR VALVES, 6-44-0052.
- ONLY IN THE CASE OF CATEGORY - II MRs, BIDDER SHALL CLEARLY WRITE ALL/ ANY DEVIATION AGAINST EACH PART/ MATERIAL OF VALVE IN THE SPACE PROVIDED FOR AND WHEREVER BIDDER AGREES WITH EIL'S SPEC BIDDER SHALL INDICATE "AGREED".
- NO CUTTING/ OVERWRITING BY BIDDER ON EIL'S SPEC IS ALLOWED.
- TESTING SHALL BE AS PER BS 6364/ BS EN ISO 28921-1 ALSO.
- VALVE SHALL BE PROVIDED WITH EXTENDED BONNET AS PER BS 6364/ BS EN ISO 28921-1 (NON COLD BOX APPLICATION).
- VENDOR SHALL CERTIFY SUITABILITY OF THE VALVE FOR INTENDED SERVICE CONDITIONS.
- VALVES TO COMPLY WITH DESIGN REQUIREMENTS OF BS-6364/ BS EN ISO 28921-1 ALSO.
- VALVES AS PER API-602 AND TESTING AS PER API-598 & BS-6364/ BS EN ISO 28921-1 ARE ALSO ACCEPTABLE.
- VALVE ENDS SHALL MATCH THICKNESSES OF CONNECTING PIPES WHICH IS AS FOLLOWS : 0.5" TO 1.5" -SCH 80S .
- FLUID HANDLED : LIQUIFIED NATURAL GAS, NATURAL GAS, FLARE GAS, FUEL GAS (CRYOGENIC SERVICE)

SIGNATURE
&
SEAL
OF
MANUFACTURER

SHEET REV NO.	0
DATE	10-Apr-2026

511EQ

Client : PETRONET LNG LIMITED		Dept. / Sect : 16/43		
Project : PDH - PP PLANT				
Location : DAHEJ, GUJARAT		Tag No : 51901		Sheet No. 1 of 1
GATE VALVE SPECIFICATION			MANUF'S OFFER	
TAG NO. : 51901 RATING : 800 STANDARD : API 602/ ISO 15761			STANDARD :	
SIZE RANGE : 0.50 " TO 1.50 " ENDS : BW TO B-16.25			MFGRS CAT/FIG : (For category -II MRs only)	
PIPING CLASS : A22K			RATING : ENDS :	
DESCRIPTION	CONSTRUCTION	MATERIAL	CONSTRUCTION	MATERIAL
BODY	FORGED	ASTM A 182 GR.F304		
BONNET	BOLTED	ASTM A 182 GR.F304		
STEM	RISING	SS 316; (NO CASTING)		
WEDGE DISC	SOLID	STELLITED		
BODY SEAT RING	RENEWABLE	STELLITED		
STEM PACKING	RENEWABLE WITH VALVE OPEN ON STREAM	CORROSION INHIBITED DIE FORMED FLEXIBLE GRAPHITE WITH BRAIDED ANTI EXTRUSION RINGS		
HAND WHEEL	NON RISING	MALLEABLE IRON/CAST ST/FAB.ST/DUCT. IRON		
BONNET BOLTS		ASTM A320 GR B8 CL.2 (IMPACT TESTED)		
BONNET NUTS		ASTM A194 GR.8 (IMPACT TESTED)		
BONNET GASKET		SP WND SS316-GRAFOIL FILLER		
SPECIAL SERVICE CONDITIONS	CRYO	MIN TEMP -196 DEG C.		
BACK SEAT & SHOULDER	INTEGRAL			
OTHERS	O.S & Y. (NOTE 5)			
HYDROSTATIC TEST PRESSURE	BODY : 2900 PSIG	SEAT : 2125 PSIG		
TEST PRESSURE WITH AIR	80 PSIG			

NOTES

- THIS VALVE SPEC SHEET SHALL BE READ IN CONJUNCTION WITH TECHNICAL NOTES FOR VALVES, 6-44-0052.
- ONLY IN THE CASE OF CATEGORY - II MRs, BIDDER SHALL CLEARLY WRITE ALL/ ANY DEVIATION AGAINST EACH PART/ MATERIAL OF VALVE IN THE SPACE PROVIDED FOR AND WHEREVER BIDDER AGREES WITH EIL'S SPEC BIDDER SHALL INDICATE "AGREED".
- NO CUTTING/ OVERWRITING BY BIDDER ON EIL'S SPEC IS ALLOWED.
- TESTING SHALL BE AS PER BS 6364/ BS EN ISO 28921-1 ALSO.
- VALVE SHALL BE PROVIDED WITH EXTENDED BONNET AS PER BS 6364/ BS EN ISO 28921-1 (NON COLD BOX APPLICATION).
- VENDOR SHALL CERTIFY SUITABILITY OF THE VALVE FOR INTENDED SERVICE CONDITIONS.
- VALVES TO COMPLY WITH DESIGN REQUIREMENTS OF BS-6364/ BS EN ISO 28921-1 ALSO.
- VALVES AS PER API-602 AND TESTING AS PER API-598 & BS-6364/ BS EN ISO 28921-1 ARE ALSO ACCEPTABLE.
- VALVE ENDS SHALL MATCH THICKNESSES OF CONNECTING PIPES WHICH IS AS FOLLOWS : 0.5" TO .75" -SCH 80S, 1.00" TO 1.5"- SCH 40S
- FLUID HANDLED : LIQUIFIED NATURAL GAS, NATURAL GAS, FLARE GAS, FUEL GAS (CRYOGENIC SERVICE)

SIGNATURE
&
SEAL
OF
MANUFACTURER

SHEET REV NO.	0
DATE	15-Apr-2025

51901

Client : PETRONET LNG LIMITED		Dept. / Sect : 16/43		
Project : PDH - PP PLANT				
Location : DAHEJ, GUJARAT		Tag No : 52003		Sheet No. 1 of 1
GLOBE VALVE SPECIFICATION			MANUF'S OFFER	
TAG NO. : 52003 RATING : 800 STANDARD : API 602/ ISO 15761			STANDARD :	
SIZE RANGE : 0.50 " TO 1.50 " ENDS : SW 3000 TO B-16.11			MFGRS CAT/FIG : (For category -II MRs only)	
PIPING CLASS : A40A,A42A,A4A,B40A,B42A,B4A,D4A			RATING : ENDS :	
DESCRIPTION	CONSTRUCTION	MATERIAL	CONSTRUCTION	MATERIAL
BODY	FORGED	ASTM A 350 GR.LF2 CL. 1		
BONNET	BOLTED	ASTM A 350 GR.LF2 CL. 1		
STEM	RISING	SS316 (NO CASTING), 32 RMS FINISH		
DISC	LOOSE PLUG TYPE	STELLITED		
BODY SEAT RING	RENEWABLE/NON RENEWABLE	STELLITED		
STEM PACKING	RENEWABLE WITH VALVE OPEN ON STREAM	CORROSION INHIBITED DIE FORMED FLEXIBLE GRAPHITE WITH BRAIDED ANTI EXTRUSION RINGS		
HAND WHEEL	RISING	MALLEABLE IRON/CAST ST/FAB.ST/DUCT. IRON		
BONNET BOLTS		ASTM A320 GR L7		
BONNET NUTS		ASTM A194 GR 7		
BONNET GASKET		SP WND SS316 WITH GRAFOIL FILLER		
OTHERS	O S & Y			
SPECIAL SERVICE CONDITION	LT	MIN. TEMP. -45 DEG.C.		
BACK SEAT & SHOULDER	INTEGRAL			
HYDROSTATIC TEST PRESSURE	BODY : 2975 PSIG	SEAT : 2175 PSIG		
TEST PRESSURE WITH AIR	80 PSIG			

NOTES

- THIS VALVE SPEC SHEET SHALL BE READ IN CONJUNCTION WITH TECHNICAL NOTES FOR VALVES, 6-44-0052.
- ONLY IN THE CASE OF CATEGORY - II MRs,BIDDER SHALL CLEARLY WRITE ALL/ ANY DEVIATION AGAINST EACH PART/ MATERIAL OF VALVE IN THE SPACE PROVIDED FOR AND WHEREVER BIDDER AGREES WITH EIL'S SPEC BIDDER SHALL INDICATE "AGREED".
- NO CUTTING/ OVERWRITING BY BIDDER ON EIL'S SPEC IS ALLOWED.
- TESTING SHALL BE AS PER BS-6364/ BS EN ISO 28921-1 ALSO.
- VALVES SHALL BE PROVIDED WITH EXTENDED BONNET AS PER BS 6364/ BS EN ISO 28921-1 (NON COLD BOX APPLICATION).
- VALVES TO COMPLY WITH DESIGN REQUIREMENTS OF BS-6364/ BS EN ISO 28921-1 ALSO.

SIGNATURE & SEAL OF MANUFACTURER

SHEET REV NO.	2	3	4	5	7	8
DATE	2-Jan-1995	14-Dec-2000	28-May-2001	30-Jun-2009	9-Dec-2019	25-Jun-2025

52003

Client : PETRONET LNG LIMITED		Dept. / Sect : 16/43		
Project : PDH - PP PLANT				
Location : DAHEJ, GUJARAT		Tag No : 520AN		Sheet No. 1 of 1
GLOBE VALVE SPECIFICATION			MANUF'S OFFER	
TAG NO.: 520AN RATING: 800 STANDARD: API 602/ ISO 15761			STANDARD:	
SIZE RANGE: 0.50 " TO 1.50 " ENDS: SW 3000 TO B-16.11			MFGRS CAT/FIG:	
PIPING CLASS: B54K,D54K			(For category -II MRs only)	
			RATING: ENDS:	
DESCRIPTION	CONSTRUCTION	MATERIAL	CONSTRUCTION	MATERIAL
BODY	FORGED	ASTM A 182 GR.F316		
BONNET	BOLTED	ASTM A 182 GR.F316		
STEM	RISING	SS 316; (NO CASTING)		
DISC	LOOSE PLUG TYPE	STELLITED		
BODY SEAT RING	RENEWABLE/NON RENEWABLE	STELLITED		
STEM PACKING	RENEWABLE WITH VALVE OPEN ON STREAM	CORROSION INHIBITED DIE FORMED FLEXIBLE GRAPHITE WITH BRAIDED ANTI EXTRUSION RINGS		
HAND WHEEL	RISING	MALLEABLE IRON/CAST ST/FAB.ST/DUCT. IRON		
BONNET BOLTS		ASTM A320 GR B8 CL 2 (IMPACT TESTED)		
BONNET NUTS		ASTM A194 GR.8 (IMPACT TESTED)		
BONNET GASKET		SP WND SS316-GRAFOIL FILLER		
OTHERS	O S & Y			
SPECIAL SERVICE CONDITIONS	CRYO + H2	MIN TEMP -196 DEG. C.		
BACK SEAT & SHOULDER	INTEGRAL			
HYDROSTATIC TEST PRESSURE	BODY : 2900 PSIG	SEAT : 2125 PSIG		
TEST PRESSURE WITH AIR	80 PSIG			

NOTES

- THIS VALVE SPEC SHEET SHALL BE READ IN CONJUNCTION WITH TECHNICAL NOTES FOR VALVES, 6-44-0052.
- ONLY IN THE CASE OF CATEGORY - II MRs, BIDDER SHALL CLEARLY WRITE ALL/ ANY DEVIATION AGAINST EACH PART/ MATERIAL OF VALVE IN THE SPACE PROVIDED FOR AND WHEREVER BIDDER AGREES WITH EIL'S SPEC BIDDER SHALL INDICATE "AGREED".
- NO CUTTING/ OVERWRITING BY BIDDER ON EIL'S SPEC IS ALLOWED.
- TESTING SHALL BE AS PER BS 6364/ BS EN ISO 28921-1 ALSO.
- VALVE SHALL BE PROVIDED WITH EXTENDED BONNET AS PER BS 6364/BS EN ISO 28921-1 (NON COLD BOX APPLICATION)
- VENDOR SHALL CERTIFY SUITABILITY OF THE VALVE FOR THE INTENDED SERVICE.
- VALVES TO COMPLY WITH DESIGN REQUIREMENTS OF BS-6364/ BS EN ISO 28921-1 ALSO.
- VALVES SHALL MEET THE REQUIREMENTS FOR HYDROGEN SERVICE AS SPECIFIED IN 'TECHNICAL NOTES FOR VALVES'.

SIGNATURE
&
SEAL
OF
MANUFACTURER

SHEET REV NO.	0
DATE	10-Jul-2025

520AN

Client : PETRONET LNG LIMITED		Dept. / Sect : 16/43		
Project : PDH - PP PLANT				
Location : DAHEJ, GUJARAT		Tag No : 520EQ		Sheet No. 1 of 1
GLOBE VALVE SPECIFICATION			MANUF'S OFFER	
TAG NO.: 520EQ RATING: 800 STANDARD: API-602 SIZE RANGE: 0.50 " TO 1.50 " ENDS: SW 3000 TO B-16.11 PIPING CLASS: A44K,B44K,D44K			STANDARD: MFGRS CAT/FIG: (For category -II MRs only) RATING: ENDS:	
DESCRIPTION	CONSTRUCTION	MATERIAL	CONSTRUCTION	MATERIAL
BODY	FORGED	ASTM A 182 GR.F316		
BONNET	BOLTED	ASTM A 182 GR.F316		
STEM	RISING	SS 316; (NO CASTING)		
DISC	LOOSE PLUG TYPE	STELLITED		
BODY SEAT RING	RENEWABLE/NON RENEWABLE	STELLITED		
STEM PACKING	RENEWABLE WITH VALVE OPEN ON STREAM	CORROSION INHIBITED DIE FORMED FLEXIBLE GRAPHITE WITH BRAIDED ANTI EXTRUSION RINGS		
HAND WHEEL	RISING	MALLEABLE IRON/CAST ST/FAB.ST/DUCT. IRON		
BONNET BOLTS		ASTM A320 GR B8 CL 2 (IMPACT TESTED)		
BONNET NUTS		ASTM A194 GR.8 (IMPACT TESTED)		
BONNET GASKET		SP WND SS316-GRAFOIL FILLER		
OTHERS	O S & Y			
SPECIAL SERVICE CONDITIONS	CRYO	MIN TEMP -196 DEG. C.		
BACK SEAT & SHOULDER	INTEGRAL			
HYDROSTATIC TEST PRESSURE	BODY : 2900 PSIG	SEAT : 2125 PSIG		
TEST PRESSURE WITH AIR	80 PSIG			

NOTES

- THIS VALVE SPEC SHEET SHALL BE READ IN CONJUNCTION WITH TECHNICAL NOTES FOR VALVES, 6-44-0052.
- ONLY IN THE CASE OF CATEGORY - II MRs,BIDDER SHALL CLEARLY WRITE ALL/ ANY DEVIATION AGAINST EACH PART/ MATERIAL OF VALVE IN THE SPACE PROVIDED FOR AND WHEREVER BIDDER AGREES WITH EIL'S SPEC BIDDER SHALL INDICATE "AGREED".
- NO CUTTING/ OVERWRITING BY BIDDER ON EIL'S SPEC IS ALLOWED.
- TESTING SHALL BE AS PER BS 6364/ BS EN ISO 28921-1 ALSO.
- VALVE SHALL BE PROVIDED WITH EXTENDED BONNET AS PER BS 6364/BS EN ISO 28921-1 (NON COLD BOX APPLICATION)
- VENDOR SHALL CERTIFY SUITABILITY OF THE VALVE FOR THE INTENDED SERVICE.
- VALVES TO COMPLY WITH DESIGN REQUIREMENTS OF BS-6364/ BS EN ISO 28921-1 ALSO.
- FLUID HANDLED : LIQUIFIED NATURAL GAS, NATURAL GAS, FLARE GAS, FUEL GAS (CRYOGENIC SERVICE)

SIGNATURE
&
SEAL
OF
MANUFACTURER

SHEET REV NO.	0	1
DATE	8-Jul-2025	16-Apr-2026

520EQ

Client : PETRONET LNG LIMITED		Dept. / Sect : 16/43		
Project : PDH - PP PLANT				
Location : DAHEJ, GUJARAT		Tag No : 521EQ		Sheet No. 1 of 1
GLOBE VALVE SPECIFICATION			MANUF'S OFFER	
TAG NO.: 521EQ RATING: 1500 STANDARD: API-602 SIZE RANGE: 0.50 " TO 1.50 " ENDS: BW TO B-16.25 PIPING CLASS: E44K			STANDARD: MFGRS CAT/FIG: (For category -II MRs only) RATING: ENDS:	
DESCRIPTION	CONSTRUCTION	MATERIAL	CONSTRUCTION	MATERIAL
BODY	FORGED	ASTM A 182 GR.F316		
BONNET	WELDED/THD & SEAL WELDED	ASTM A 182 GR.F316		
STEM	RISING	SS 316; (NO CASTING)		
DISC	LOOSE PLUG TYPE	STELLITED		
BODY SEAT RING	RENEWABLE/NON RENEWABLE	STELLITED		
STEM PACKING	RENEWABLE WITH VALVE OPEN ON STREAM	CORROSION INHIBITED DIE FORMED FLEXIBLE GRAPHITE WITH BRAIDED ANTI EXTRUSION RINGS		
HAND WHEEL	RISING	MALLEABLE IRON/CAST ST/FAB.ST/DUCT. IRON		
BOLTS		ASTM A320 GR B8 CL 2 (IMPACT TESTED)		
NUTS		ASTM A194 GR.8 (IMPACT TESTED)		
OTHERS	O S & Y			
SPECIAL SERVICE CONDITIONS	CRYO	MIN TEMP -196 DEG. C.		
BACK SEAT & SHOULDER	INTEGRAL			
HYDROSTATIC TEST PRESSURE	BODY : 5400 PSIG	SEAT : 3975 PSIG		
TEST PRESSURE WITH AIR	80 PSIG			

NOTES

- 1 THIS VALVE SPEC SHEET SHALL BE READ IN CONJUNCTION WITH TECHNICAL NOTES FOR VALVES, 6-44-0052.
- 2 ONLY IN THE CASE OF CATEGORY - II MRs, BIDDER SHALL CLEARLY WRITE ALL/ ANY DEVIATION AGAINST EACH PART/ MATERIAL OF VALVE IN THE SPACE PROVIDED FOR AND WHEREVER BIDDER AGREES WITH EIL'S SPEC BIDDER SHALL INDICATE "AGREED".
- 3 NO CUTTING/ OVERWRITING BY BIDDER ON EIL'S SPEC IS ALLOWED.
- 4 TESTING SHALL BE AS PER BS 6364/ BS EN ISO 28921-1 ALSO.
- 5 VALVE SHALL BE PROVIDED WITH EXTENDED BONNET AS PER BS 6364/BS EN ISO 28921-1 (NON COLD BOX APPLICATION)
- 6 VENDOR SHALL CERTIFY SUITABILITY OF THE VALVE FOR THE INTENDED SERVICE.
- 7 VALVES TO COMPLY WITH DESIGN REQUIREMENTS OF BS-6364/ BS EN ISO 28921-1 ALSO.
- 8 VALVE ENDS SHALL MATCH THICKNESSES OF CONNECTING PIPES WHICH IS AS FOLLOWS : 0.5" TO 1.5" -SCH 80S .
- 9 FLUID HANDLED : LIQUIFIED NATURAL GAS, NATURAL GAS, FLARE GAS, FUEL GAS (CRYOGENIC SERVICE)

SIGNATURE
&
SEAL
OF
MANUFACTURER

SHEET REV NO.	0	1
DATE	9-Jul-2025	16-Apr-2026

521EQ

Client : PETRONET LNG LIMITED			Dept. / Sect : 16/43	
Project : PDH - PP PLANT				
Location : DAHEJ, GUJARAT		Tag No : 53003		Sheet No. 1 of 1
CHECK VALVE SPECIFICATION			MANUF'S OFFER	
TAG NO. : 53003 RATING : 800 STANDARD : API 602/ ISO 15761			STANDARD :	
SIZE RANGE : 0.50 " TO 1.50 " ENDS : SW 3000 TO B-16.11			MFGRS CAT/FIG : (For category -II MRs only)	
PIPING CLASS : A40A,A42A,A4A,B40A,B42A,B4A,D4A			RATING : ENDS :	
DESCRIPTION	CONSTRUCTION	MATERIAL	CONSTRUCTION	MATERIAL
BODY	FORGED	ASTM A 350 GR.LF2 CL.1		
COVER	BOLTED	ASTM A 350 GR.LF2 CL.1		
DISC/PISTON		STELLITED		
BODY SEAT RING	RENWABLE/NON-RENE WABLE	STELLITED		
DISC HINGE/HINGE PIN				
COVER STUD BOLT		ASTM A320 GR L7		
COVER NUT		ASTM A194 GR 4/GR 7		
COVER GASKET		SP WND SS316-GRAFOIL FILLER		
TYPE	LIFT CHECK TYPE			
OTHERS				
SPECIAL SERVICE CONDITIONS	LT	MIN TEMP -45 DEG.C.		
WASHER,NUT,PIN				
HYDROSTATIC TEST PRESSURE	BODY : 2975 PSIG	SEAT : 2175 PSIG		
TEST PRESSURE WITH AIR				

NOTES

- 1 THIS VALVE SPEC SHEET SHALL BE READ IN CONJUNCTION WITH TECHNICAL NOTES FOR VALVES, 6-44-0052.
- 2 ONLY IN THE CASE OF CATEGORY - II MRs,BIDDER SHALL CLEARLY WRITE ALL/ ANY DEVIATION AGAINST EACH PART/ MATERIAL OF VALVE IN THE SPACE PROVIDED FOR AND WHEREVER BIDDER AGREES WITH EIL'S SPEC BIDDER SHALL INDICATE "AGREED".
- 3 NO CUTTING/ OVERWRITING BY BIDDER ON EIL'S SPEC IS ALLOWED.
- 4 TESTING SHALL BE AS PER BS-6364 ALSO.
- 5 VALVES TO COMPLY WITH DESIGN REQUIREMENTS OF BS-6364 ALSO.
- 6 VALVES SHALL BE OF STANDARD BORE DESIGN.

SIGNATURE
&
SEAL
OF
MANUFACTURER

SHEET REV NO.	2	3	4	5	6
DATE	2-Jan-1995	14-Dec-2000	28-May-2001	30-Jun-2009	26-Apr-2018

53003

Client : PETRONET LNG LIMITED		Dept. / Sect : 16/43		
Project : PDH - PP PLANT				
Location : DAHEJ, GUJARAT		Tag No : 530AN		Sheet No. 1 of 1
CHECK VALVE SPECIFICATION			MANUF'S OFFER	
TAG NO.: 530AN RATING: 800 STANDARD: API 602/ ISO 15761			STANDARD:	
SIZE RANGE: 0.50 " TO 1.50 " ENDS: SW 3000 TO B-16.11			MFGRS CAT/FIG:	
PIPING CLASS: B54K,D54K			(For category -II MRs only)	
			RATING: ENDS:	
DESCRIPTION	CONSTRUCTION	MATERIAL	CONSTRUCTION	MATERIAL
BODY	FORGED	ASTM A 182 GR.F316		
COVER	BOLTED	ASTM A 182 GR.F316		
DISC/PISTON		STELLITED		
BODY SEAT RING	RENEWABLE/NON-RENEWABLE	STELLITED		
DISC HINGE/HINGE PIN				
COVER STUD BOLT		ASTM A320 GR B8 CL 2 (IMPACT TESTED)		
COVER NUT		ASTM A194 GR 8 (IMPACT TESTED)		
COVER GASKET		SP WND SS316-GRAFOIL FILLER		
TYPE	LIFT CHECK TYPE			
OTHERS				
SPECIAL SERVICE CONDITIONS	LT/CRYO+ HYDROGEN	MIN TEMP -196 DEG. C./MAX TEMP 265 DEG.C		
WASHER,NUT,PIN				
HYDROSTATIC TEST PRESSURE	BODY : 2900 PSIG	SEAT : 2125 PSIG		
TEST PRESSURE WITH AIR				

NOTES

- 1 THIS VALVE SPEC SHEET SHALL BE READ IN CONJUNCTION WITH TECHNICAL NOTES FOR VALVES, 6-44-0052.
- 2 ONLY IN THE CASE OF CATEGORY - II MRs,BIDDER SHALL CLEARLY WRITE ALL/ ANY DEVIATION AGAINST EACH PART/ MATERIAL OF VALVE IN THE SPACE PROVIDED FOR AND WHEREVER BIDDER AGREES WITH EIL'S SPEC BIDDER SHALL INDICATE "AGREED".
- 3 NO CUTTING/ OVERWRITING BY BIDDER ON EIL'S SPEC IS ALLOWED.
- 4 TESTING SHALL BE AS PER BS 6364/BS EN ISO 28921-1 ALSO.
- 5 VENDOR SHALL CERTIFY SUITABILITY OF THE VALVE FOR INTENDED SERVICE.
- 6 VALVES TO COMPLY WITH DESIGN REQUIREMENTS OF BS-6364/BS EN ISO 28921-1 ALSO.
- 7 VALVES SHALL BE OF STANDARD BORE DESIGN.
- 8 VALVES SHALL MEET THE REQUIREMENTS FOR HYDROGEN SERVICE AS SPECIFIED IN 'TECHNICAL NOTES FOR VALVES'.

SIGNATURE
&
SEAL
OF
MANUFACTURER

SHEET REV NO.	0
DATE	10-Apr-2026

530AN

Client : PETRONET LNG LIMITED		Dept. / Sect : 16/43		
Project : PDH - PP PLANT				
Location : DAHEJ, GUJARAT		Tag No : 530EQ		Sheet No. 1 of 1
CHECK VALVE SPECIFICATION			MANUF'S OFFER	
TAG NO.: 530EQ RATING: 800 STANDARD: API 602/ ISO 15761 SIZE RANGE: 0.50 " TO 1.50 " ENDS: SW 3000 TO B-16.11 PIPING CLASS: A44K,B44K,D44K			STANDARD: MFGRS CAT/FIG: (For category -II MRs only) RATING: ENDS:	
DESCRIPTION	CONSTRUCTION	MATERIAL	CONSTRUCTION	MATERIAL
BODY	FORGED	ASTM A 182 GR.F316		
COVER	BOLTED	ASTM A 182 GR.F316		
DISC/PISTON		STELLITED		
BODY SEAT RING	RENEWABLE/NON-RENEWABLE	STELLITED		
DISC HINGE/HINGE PIN				
COVER STUD BOLT		ASTM A320 GR B8 CL 2 (IMPACT TESTED)		
COVER NUT		ASTM A194 GR 8 (IMPACT TESTED)		
COVER GASKET		SP WND SS316-GRAFOIL FILLER		
TYPE	LIFT CHECK TYPE			
OTHERS				
SPECIAL SERVICE CONDITIONS	CRYO	MIN TEMP -196 DEG. C.		
WASHER,NUT,PIN				
HYDROSTATIC TEST PRESSURE	BODY : 2900 PSIG	SEAT : 2125 PSIG		
TEST PRESSURE WITH AIR				

NOTES

- 1 THIS VALVE SPEC SHEET SHALL BE READ IN CONJUNCTION WITH TECHNICAL NOTES FOR VALVES, 6-44-0052.
- 2 ONLY IN THE CASE OF CATEGORY - II MRs,BIDDER SHALL CLEARLY WRITE ALL/ ANY DEVIATION AGAINST EACH PART/ MATERIAL OF VALVE IN THE SPACE PROVIDED FOR AND WHEREVER BIDDER AGREES WITH EIL'S SPEC BIDDER SHALL INDICATE "AGREED".
- 3 NO CUTTING/ OVERWRITING BY BIDDER ON EIL'S SPEC IS ALLOWED.
- 4 TESTING SHALL BE AS PER BS 6364/BS EN ISO 28921-1 ALSO.
- 5 VENDOR SHALL CERTIFY SUITABILITY OF THE VALVE FOR INTENDED SERVICE.
- 6 VALVES TO COMPLY WITH DESIGN REQUIREMENTS OF BS-6364/BS EN ISO 28921-1 ALSO.
- 7 VALVES SHALL BE OF STANDARD BORE DESIGN.
- 8 FLUID HANDLED : LIQUIFIED NATURAL GAS, NATURAL GAS, FLARE GAS, FUEL GAS (CRYOGENIC SERVICE)

SIGNATURE
&
SEAL
OF
MANUFACTURER

SHEET REV NO.	0
DATE	10-Apr-2026

530EQ

Client : PETRONET LNG LIMITED		Dept. / Sect : 16/43		
Project : PDH - PP PLANT				
Location : DAHEJ, GUJARAT		Tag No : 531EQ		Sheet No. 1 of 1
CHECK VALVE SPECIFICATION			MANUF'S OFFER	
TAG NO.: 531EQ RATING: 1500 STANDARD: API 602/ ISO 15761			STANDARD:	
SIZE RANGE: 0.50 " TO 1.50 " ENDS: BW TO B-16.25			MFGRS CAT/FIG: (For category -II MRs only)	
PIPING CLASS: E44K			RATING: ENDS:	
DESCRIPTION	CONSTRUCTION	MATERIAL	CONSTRUCTION	MATERIAL
BODY	FORGED	ASTM A 182 GR.F316		
COVER	WELDED/THD. & SEAL WELDED	ASTM A 182 GR.F316		
DISC/PISTON		STELLITED		
BODY SEAT RING	RENEWABLE/NON-REN EWABLE	STELLITED		
DISC HINGE/HINGE PIN				
COVER STUD BOLT				
COVER NUT				
COVER GASKET				
TYPE	LIFT CHECK TYPE			
OTHERS				
SPECIAL SERVICE CONDITIONS	CRYO	MIN TEMP -196 DEG. C.		
WASHER,NUT,PIN				
HYDROSTATIC TEST PRESSURE	BODY : 5400 PSIG	SEAT : 3975 PSIG		
TEST PRESSURE WITH AIR				

NOTES

- 1 THIS VALVE SPEC SHEET SHALL BE READ IN CONJUNCTION WITH TECHNICAL NOTES FOR VALVES, 6-44-0052.
- 2 ONLY IN THE CASE OF CATEGORY - II MRs,BIDDER SHALL CLEARLY WRITE ALL/ ANY DEVIATION AGAINST EACH PART/ MATERIAL OF VALVE IN THE SPACE PROVIDED FOR AND WHEREVER BIDDER AGREES WITH EIL'S SPEC BIDDER SHALL INDICATE "AGREED".
- 3 NO CUTTING/ OVERWRITING BY BIDDER ON EIL'S SPEC IS ALLOWED.
- 4 TESTING SHALL BE AS PER BS 6364/BS EN ISO 28921-1 ALSO.
- 5 VENDOR SHALL CERTIFY SUITABILITY OF THE VALVE FOR INTENDED SERVICE.
- 6 VALVES TO COMPLY WITH DESIGN REQUIREMENTS OF BS-6364/BS EN ISO 28921-1 ALSO.
- 7 VALVES SHALL BE OF STANDARD BORE DESIGN.
- 8 FLUID HANDLED : LIQUIFIED NATURAL GAS, NATURAL GAS, FLARE GAS, FUEL GAS (CRYOGENIC SERVICE).
- 9 VALVE ENDS SHALL MATCH THICKNESSES OF CONNECTING PIPES WHICH ARE AS FOLLOWS : 0.5" TO 1.5" - SCH 80S

SIGNATURE
&
SEAL
OF
MANUFACTURER

SHEET REV NO.	0
DATE	10-Apr-2026

531EQ

Client : PETRONET LNG LIMITED		Dept. / Sect : 16/43		
Project : PDH - PP PLANT				
Location : DAHEJ, GUJARAT		Tag No : 53901		Sheet No. 1 of 1
CHECK VALVE SPECIFICATION			MANUF'S OFFER	
TAG NO. : 53901 RATING : 800 STANDARD : API 602/ ISO 15761			STANDARD :	
SIZE RANGE : 0.50 " TO 1.50 " ENDS : BW TO B-16.25			MFGRS CAT/FIG : (For category -II MRs only)	
PIPING CLASS : A22K			RATING : ENDS :	
DESCRIPTION	CONSTRUCTION	MATERIAL	CONSTRUCTION	MATERIAL
BODY	FORGED	ASTM A 182 GR.F304		
COVER	WELDED/THD. & SEAL WELDED	ASTM A 182 GR.F304		
DISC/PISTON		STELLITED		
BODY SEAT RING	RENEWABLE/NON-RENEWABLE	STELLITED		
DISC HINGE/HINGE PIN				
COVER STUD BOLT				
COVER NUT				
COVER GASKET				
TYPE	LIFT CHECK TYPE			
OTHERS				
SPECIAL SERVICE CONDITIONS	CRYO	MIN TEMP -196 DEG. C.		
WASHER,NUT,PIN				
HYDROSTATIC TEST PRESSURE	BODY : 2900 PSIG	SEAT :2125 PSIG		
TEST PRESSURE WITH AIR				

NOTES

- THIS VALVE SPEC SHEET SHALL BE READ IN CONJUNCTION WITH TECHNICAL NOTES FOR VALVES, 6-44-0052.
- ONLY IN THE CASE OF CATEGORY - II MRs,BIDDER SHALL CLEARLY WRITE ALL/ ANY DEVIATION AGAINST EACH PART/ MATERIAL OF VALVE IN THE SPACE PROVIDED FOR AND WHEREVER BIDDER AGREES WITH EIL'S SPEC BIDDER SHALL INDICATE "AGREED".
- NO CUTTING/ OVERWRITING BY BIDDER ON EIL'S SPEC IS ALLOWED.
- TESTING SHALL BE AS PER API 598 & BS 6364 ALSO.
- VENDOR SHALL CERTIFY SUITABILITY OF THE VALVE FOR INTENDED SERVICE.
- VALVES TO COMPLY WITH DESIGN REQUIREMENTS OF BS-6364 ALSO.
- VALVES SHALL BE OF STANDARD BORE DESIGN.
- VALVE ENDS SHALL MATCH THICKNESSES OF CONNECTING PIPES WHICH ARE AS FOLLOWS:: 0.5" TO 0.75" - SCH 80S & 1.0"-1.5"- SCH 40S.
- FLUID HANDLED : LIQUIFIED NATURAL GAS, NATURAL GAS, FLARE GAS, FUEL GAS (CRYOGENIC SERVICE)



SIGNATURE
&
SEAL
OF
MANUFACTURER

SHEET REV NO.	0
DATE	10-Apr-2026

53901

वाल्वों के लिए तकनीकी टिप्पणियाँ

TECHNICAL NOTES FOR VALVES

9	09.07.24	REVISED AND ISSUED AS STANDARD SPECIFICATION	 PK	 SH	 GB	MN
8	15.02.23	REVISED AND ISSUED AS STANDARD SPECIFICATION	PK	SH	GB	SM
7	13.07.17	REVISED AND ISSUED AS STANDARD SPECIFICATION	PK	SH	MI	RN
6	04.08.10	REVISED AND ISSUED AS STANDARD SPECIFICATION	RN	ATD	SC	
5	04.07.08	REVISED AND ISSUED AS STANDARD SPECIFICATION	RN	SC	DM	VC
4	15.11.00	REVISED AND ISSUED AS STANDARD SPECIFICATION	RN	BRB	NS	MI
Rev. No	Date	Purpose	Prepared by	Checked by	Standards Committee Convenor	Standards Bureau Chairman
					Approved by	

Abbreviations:

AARH :	Arithmetic Average Roughness Height
API :	American Petroleum Institute
ASME :	American Society of Mechanical Engineers
ASTM :	American Society for Testing & Materials
BGO :	Bevel Gear Operator
BHN :	Brinell Hardness Number
BIS :	Bureau of Indian Standards
BS :	British Standard
BVIS :	Bureau Veritas Industrial Services
BW :	Butt Weld
CAT :	Category
CEIL :	Certification Engineers International Limited
CS :	Carbon Steel
DFT :	Dry Film Thickness
DNV :	Det Norske Veritas
DP :	Dye-Penetrant
eDMS :	Electronic Document Management System
IBR :	Indian Boiler Regulations
IGC :	Inter Granular Corrosion
IS :	Indian Standard
ISO :	International Organisation for Standardisation
LC :	Lock Closed
LO :	Lock Open
LT :	Low Temperature
LTCS :	Low Temperature Carbon Steel
MOV :	Motor Operated Valve
MP :	Magnetic Particle
MR :	Material Requisition
NACE :	National Association for Corrosion engineers
NDT :	Non Destructive Testing
NPT :	National Pipe Thread
PMI :	Positive Material Identification
PO :	Purchase Order
PR :	Purchase Requisition
Ra :	Roughness average
RFQ :	Request for Quotation
SCRD :	Screwed
SS :	Stainless Steel
SW :	Socket Weld
TUV :	Technischer Überwachungsverein
WAFL :	Lugged Wafer Type

Piping Standards Committee

Convenor: Mr. G. Balaji

Members: Mr. Udayan Chakravarty
Mr. Rameshwar Prasad
Mr. K. Anjaneyulu (SMED)
Mr. Rajesh Chitara (SMMS)
Dr. Sudip Paul (Structural)
Mr. Harsh Vardhan (Projects)
Mr. P.K. Rai (Construction)

CONTENTS

1.0	GENERAL.....	4
2.0	DOCUMENTATION	4
3.0	DESIGN AND CONSTRUCTION	5
4.0	OPERATION.....	11
5.0	INSPECTION AND TESTING.....	12
6.0	RADIOGRAPHY OF CAST VALVES	133
7.0	IBR CERTIFICATION.....	14
8.0	MARKING	144
9.0	DESPATCH.....	144
10.0	ATTACHMENTS.....	155
11.0	REFERENCES	155

1.0 GENERAL

- 1.1 Vendor shall supply valves in accordance with the valve specification sheets along with auxiliaries, if any, such as gear operator, bypasses, drains, locking etc. wherever specified in the specification sheets, subject notes and other enclosures to the material requisition (MR).
- 1.2 Vendor shall quote in strict accordance with the valve data / specification sheets, subject technical notes and all other enclosures to the MR. For 'Cat-I valves', no deviations whatsoever shall be accepted. For Cat-II Valves, if exceptions/ deviations become absolutely must, the same shall be requested as explained in clause 2.3.6 giving reasons for seeking such exceptions/ deviations. In case Post order concessions/ deviations are unavoidable, the request must be made by BIDDER through online system of EIL eDMS in accordance with 6-78-0001.
- 1.3 All codes and standards for manufacture, testing, inspection etc. shall be of latest editions as on issue date of RFQ.
- 1.4 In case of any conflict amongst documents attached with the MR, the most stringent shall govern and Owner's/ EIL decision shall be final in this regard.

2.0 DOCUMENTATION

- 2.1 All document submissions to EIL shall be through EIL eDMS.
- 2.2 For 'Cat-I' valves, no documents shall be submitted with the offer.
- 2.3 For 'Cat-II' valves, vendor shall submit the following documents with the offer:
- 2.3.1 Manufacturer's complete descriptive and illustrative catalogue / literature.
- 2.3.2 Detailed dimensioned cross section drawing with parts / material lists, weight etc.
- 2.3.3 Drawings for valves with accessories like gear operator, hydraulic / pneumatic operator, motor, extension bonnet, extended stems with stands, bypass etc. giving major salient dimensions and weights.
- 2.3.4 One copy of the valve specification sheets signed as "Accepted" by the manufacturer. Deviations, if any shall be marked as applicable on the valve specification sheet.
- 2.3.5 If the valve is regretted or has no deviation, the manufacturer shall write clearly on valve specification sheets as "Regret" or "No Deviation".
- 2.3.6 If there is any deviation, the same shall be listed clausewise.
- 2.3.7 On failure to submit documents as specified in clauses 2.3.1 to 2.3.6 above, the offer is likely to be rejected.
- 2.4 The following documents shall be submitted through eDMS of EIL after placement of the order:

- 2.4.1 For Cat-I valves of size 2" and above where end-to-end/ face-to-face dimensions are to manufacturers' standards, detailed dimensioned cross section drawing with parts, materials, weight, etc. shall be submitted for records/ information.
- 2.4.2 For 'Cat-II' valves, Vendor shall submit for review drawings mentioned in clauses 2.3.2 & 2.3.3 before start of manufacture. No other drawings shall be submitted for review unless otherwise mentioned in MR.
- 2.4.3 Test report shall be supplied for all mandatory tests as per the applicable code. Test reports shall also be furnished for any supplementary tests as specified in clauses 3.13, 3.14 & 3.15.
- 2.4.4 Material test certificates (physical properties, chemical composition & heat treatment report including Chart) of the pressure containing parts shall be furnished for the valves supplied. Material test certificates for the other parts shall also be furnished for verification during inspection.
- 2.5 In addition to submissions through EIL eDMS, Catalogues/Drawings shall be submitted in hard copies (6 sets) and soft copies (2 CDs/DVDs) along with delivery for Purchaser's record for all categories/types of valves.

3.0 DESIGN AND CONSTRUCTION

- 3.1 Valve shall be designed, manufactured, tested, inspected and marked as per the manufacturing standards, design codes and standards indicated in the respective valve specification sheets. Any conflict between the requisition, enclosures, specification sheets and referred standards/ codes shall be brought to the notice of the purchaser for clarifications and resolution, before proceeding with the manufacture. The purchaser's decision shall be final and binding to the vendor. The drawings submitted for review shall not include any deviations except as communicated in writing in Deviation permits. The Drawings shall be reviewed only for design and construction features.
- 3.2 All flanged valves shall have flanges integral (except forged valves) with the valve body. Flange face finish shall be normally specified in the valve specification sheet as 125 AARH etc. The interpretation for range of face finish shall be as follows:

Stock Finish	:	1000 μ in AARH max.
125 AARH	:	Serrations with 125 to 250 μ in AARH
63 AARH	:	32 to 63 μ in AARH

- 3.3 For all weld end valves with bevel end as per ASME B16.25, the contour of bevel shall be as follows:

Material	Wall Thickness	Weld Contour
Carbon Steel (Except Low Temp. Carbon Steel)	Upto 22 mm	Figure 2 Type A
	> 22 mm	Figure 3 Type A
Alloy Steel, Stainless Steel & Low Temp. Carbon Steel	Upto 10 mm	Figure 4
	> 10 mm & Upto 25 mm	Figure 5 Type A
	> 25 mm	Figure 6 Type A

Valve ends shall match thickness of the connecting pipe. Sloping of inside contour of valves shall be done wherever necessary to achieve this.

3.4 For flanged valves with ring joint flanges the hardness shall be as follows:

Flange Material	Min. Hardness of Groove (BHN)
Carbon Steel	140
1% Cr to 5% Cr, 9% Cr	150
9Cr-1Mo-V	190
Type 304, 316, 321, 347	160
Type 304L, 316L	150
Inconel UNS N06625	220
Incoloy UNS N08825	210
Duplex SS UNS S32205, UNS S31803	250

3.5 Following requirements for check valves shall be met over and above the valve specification sheet requirements:

3.5.1 Unless specified otherwise in the data sheet all check valves 3" & above (except in Class 900, Class 1500 & Class 2500 rating) shall have a drain boss at location "G" (Refer Fig.No.1 of ASME B16.34) where pocket is formed in valve body. A tapped drain hole with plug shall be provided as per ASME B16.34. Threads shall be as per ASME B1.20.1 (Taper) NPT.

3.5.2 For heavy check valves, provisions shall be available for lifting by way of lugs, eye bolts and other such standard devices.

3.6 If an overlay weld-deposit is used for the body seat ring seating surface, the corrosion resistance of the seat ring base material shall be at least equal to the corrosion resistance of the material of the shell.

3.7 Following valve bypass requirements shall be met:

3.7.1 By-pass requirement for Gate valves shall be as follows unless otherwise mentioned.

ASME 150 Class	On sizes 26" and above
ASME 300 Class	On sizes 16" and above
ASME 600 Class	On sizes 6" and above
ASME 900 Class	On sizes 4" and above
ASME 1500 Class	On sizes 4" and above
ASME 2500 Class	On sizes 3" and above

3.7.2 The by-pass piping arrangement shall be such that clearance between main valve body and by-pass assembly shall be the minimum possible for layout reasons. Vendor shall follow the sketch enclosed in Specification No. 6-44-0052-A1.

3.7.3 By-pass valve shall be a globe valve. The sizes shall be as under:

On main valve \leq 4" : 1/2"

On main valve 6" to 8"	:	3/4"
On main valve 10"& above	:	1"

By-pass piping shall be of same metallurgy as main valve. The by-pass piping, fittings and valve tag numbers shall be as specified in Specification No. 6-44-0052-A2. In case details of by-pass arrangement for any Valve tag number is missing, Vendor shall bring the same to notice of EIL and provide by-pass as per details specified. Bends are not acceptable in place of elbows except in the location specified in 6-44-0052-A1.

- 3.7.4 Vendor shall supply the by-pass valve duly tested and fitted to the main valve with proper supporting from the main valve body, as required. Valves with by-pass shall have the direction of flow marked on the bypass valve only. By-pass attachment to the main valve body shall not be screwed. All fillet welds for by-pass installation shall be 100% examined by DP/MP test and Butt-weld joints shall be 100% examined by radiography.
- 3.8 Valve body / bonnet shall be forged / cast as specified. Forgings are acceptable in place of casting but not vice-versa.
- 3.9 Stem shall be forged or machined from forged / rolled bar. No casting is permitted. However, integral stem of cast material is acceptable for Plug valves.
- 3.10 Stellite / hardfacing by deposition, shall be minimum 1.6 mm.
- 3.11 Renewable seat rings shall be seal welded for valves of size 3" and above to prevent loosening in service.
- 3.12 For Low Temperature & Cryogenic valve requirements, refer Specification. No. 6-44-0052-A3 unless otherwise specified.
- 3.13 For Hydrogen service valve requirements, refer Specification. No. 6-44-0052-A4 unless otherwise specified.
- 3.14 Valves under 'NACE' category shall meet the requirements specified in MR-0103 unless otherwise specified.
- 3.15 For all austenitic stainless steel valves Inter Granular Corrosion (IGC) test shall be conducted as per the following:
- 3.15.1 ASTM A262 Practice 'B' with acceptance criteria of '60 mils/year (max.)' for all materials - forged, rolled, wrought and casting.
- Or
- ASTM A262 Practice 'E' with acceptance criteria of 'No cracks as observed from 20X magnification' for all materials other than castings. 'Microscopic structure to be observed from 250X magnification' in addition.
- 3.15.2 When specifically asked for in MR for high temperature application of some grades of austenitic stainless steel (eg. SS309, 310, 316, 316H etc.) ASTM A262 Practice 'C' with acceptance criteria of '15 mils/year (max.)' shall be conducted.
- 3.15.3 For the IGC test as described in Clauses 3.15.1 & 3.15.2, two sets of samples shall be drawn from each solution annealing lot. One set shall correspond to the highest Carbon content and the other to the highest pressure rating. When testing is conducted as per practice 'E', photograph of the microscopic structure shall be submitted for record.

- 3.16** All types of 321 or 347 stainless steel valves shall be in a stabilised heat treated condition. Stabilising heat treatment shall be carried out subsequent to the normal solution annealing. Soaking temperature and holding time for stabilising heat treatment shall be 900°C and 4 hours respectively.
- 3.17** Spiral wound bonnet gaskets are to be provided with inner/outer ring except when encapsulated gaskets type body-bonnet joints are employed. Outer ring may be avoided in case of non-circular spiral wound gasket used in Class 150 valve provided the outermost layer of spiral touches the bolts ascertaining the centering.
- 3.18** All Stainless Steel Castings shall be solution heat treated.
- 3.19** Only normalized and tempered material shall be used in the following specifications:

Castings : A217 Gr.WC1, A217 Gr.WC4, A217 Gr.WC5, A217 Gr.WC6, A217 Gr.WC9, A217 Gr.C5, A217 Gr.C12

Forgings : A182 Gr.F11 Cl.2, A182 Gr.F12 Cl.2

3.20 Ball / Plug / Butterfly Valves

- 3.20.1 As a prequalification, fire safe test as per API 607 / API 6FA / BS EN ISO 10497 (Supersedes BS 6755 Part II) shall be carried out on soft seated ball, plug & butterfly valves and also on lubricated plug valves. The test shall be witnessed and certified by a third party inspection agency like Lloyds, BVIS, DNV, TUV or EIL/ CEIL unless otherwise specified. The vendor has to submit test certificate for the particular design of the valve offered, if fire safe design is required as per the Valve Material Specification sheet.
- 3.20.2 Each valve shall be supplied with a lever / wrench except for gear operated / motor operated valves.
- 3.20.3 Soft-seated ball, plug & butterfly valves shall be supplied with antistatic devices.
- 3.20.4 BW / SW end ball valves shall have a 100 mm long seamless pipe nipple welded to each end of the valve. Nipples are to be welded prior to assembling soft seats / seals. Specifications of the nipples shall be as indicated in the MR.
- 3.20.5 The ball of ball valve shall not protrude outside the end flanges of valve.
- 3.20.6 Ball valves shall be of floating ball/trunnion mounted type as per following:
- | | | |
|-------------------|--------------|------------------|
| Class 150 | 8" & below | Floating ball |
| | 10" & above | Trunnion mounted |
| Class 300 | 4" & below | Floating ball |
| | 6" & above | Trunnion mounted |
| Class 600 & above | 1.5" & below | Floating ball |
| | 2" & above | Trunnion mounted |
- 3.20.7 Unless otherwise specified in the data sheets, bore of all reduced bore ball valves shall be limited to one size lower than the nominal bore.

3.20.8 In case of ball valves, the ball shall have a cylindrical bore and shall be of solid construction except in the case of rising stem ball valves or where otherwise specified.

3.21 Motor Operated Valves:

3.21.1 The MOVs are to be installed in an open area and the actuators shall be suitable for all weather conditions. The testing of complete assemblies of MOVs along with the actuators shall be done by the supplier at his works.

3.21.2 Vendor shall be solely responsible for selection of suitable actuators & actuator control system. Vendor shall be single point responsible for the complete system (i.e. valves, actuators, actuators control system etc.).

3.21.3 Valve with motorized actuators shall be suitable for installation in horizontal/vertical lines.

3.21.4 All MOVs shall be provided with hand wheel for manual operation.

3.22 In case flange dimension standard / Butt weld end thickness have not been specified in Valve Material Specification attached with the MR, Vendor to obtain the same from EIL and supply strictly in line with specifications.

3.23 Yoke material shall be same as bonnet material where maximum temperature specified is more than 427°C.

3.24 Face to Face / End to End Dimensions of Valves:

The Face to Face dimensions for Flanged valves and End to End Dimensions for Butt Welded Valves shall be strictly as given below unless otherwise specified in the VMS sheet. Valves with Face-to-Face/End-to-End dimensions as per Manufacturers' Standards are acceptable only where not covered in the Dimension Standards listed below.

3.24.1 Gate Valves:

Type	Face-to-Face/End-to-End Dimension
Flanged End	Dimension 'A' for Solid Wedge & Double Disc Gate Valves as per ASME B16.10
Butt Welding End	Dimension 'B' for Short Pattern Gate Valves up to the sizes covered in ASME B16.10. For sizes not covered under Short Pattern, Dimension 'B' for Long Pattern Gate Valves as per ASME B16.10 shall be followed.

3.24.2 Globe Valves:

Type	Face-to-Face/End-to-End Dimension
Flanged End	Dimension 'A' for Globe Valves as per ASME B16.10
Butt Welding End	Dimension 'B' for Short Pattern Globe Valves up to the sizes covered in ASME B16.10. For sizes not covered under Short pattern, Dimension 'B' for Long Pattern Globe Valves as per ASME B16.10 shall be followed.

3.24.3 Check Valves:

Type	Face-to-Face/End-to-End Dimension
Flanged End Swing Check	Dimension 'A' for Swing Check Valves as per ASME B16.10
Butt Welding End Swing Check	Dimension 'B' for Short Pattern Swing Check Valves up to the sizes covered in ASME B16.10. For sizes not covered under short pattern, Dimension 'B' for Long Pattern Swing Check Valves as per ASME B16.10 shall be followed.
Lugged/Double Flanged Dual Plate Check Valves	As per API 594

3.24.4 Ball Valves:

The face-to-face dimensions of all ball valves shall be same as those of gate valves of the corresponding ASME Class rating as given in Clause 3.24.1 (except 10" onwards in Class 150 where the face-to-face dimensions shall be as per ASME B16.10 long pattern).

3.24.5 Plug Valves:

Class Rating	Face-to-Face Dimension
Class 150	Short Pattern as per ASME B16.10 up to 12" Venturi Pattern as per ASME B16.10 for above 12"
Class 300 & 600	Short Pattern as per ASME B16.10 up to 4" Venturi Pattern as per ASME B16.10 for above 4"

3.24.6 Butterfly Valves:

The face to face dimensions for butterfly valves shall be as per BS EN 558/API 609. For Class 150 Butterfly valves, Series 13 shall be followed and for Class 300 Butterfly valves, Series 14 shall be followed, unless otherwise specified.

3.25 In addition to all types of BW/SW ball valves, any other type of soft seated BW / SW end valve shall have a 100 mm long seamless pipe nipple welded to each end of the valve. Nipples are to be welded prior to assembling soft seats / seals. Specifications of the nipples shall be as indicated in the MR.

3.26 All Butt welds shall be 100% radiographed and all socket welds shall be 100% DP/MP tested.

3.27 Fugitive Emission Requirements:

Unless otherwise mentioned in VMS sheet, all valves with stem packing shall comply with the fugitive emission requirements detailed below as a pre-qualification.

3.27.1 Gate valves as per API-600 and all Gate/Globe valves as per API-602 shall comply with fugitive emission requirements of API 624.

Gate valves of Class rating 900 & above, Gate valves of size 26" & above and Globe valves of size 2" & above or valves where API-624 is not applicable due to non-graphite stem packing material, shall comply with Fugitive emission requirement of ISO-15848-1.

3.27.2 Quarter turn valves shall comply with Fugitive emission requirement of API 641. Quarter turn valves where API-641 is not applicable due to non-graphite stem packing material, shall comply with Fugitive emission requirement of ISO-15848-1.

3.27.3 As a prequalification, Fugitive emission type test as per Cl. 3.27.1 & 3.27.2 above shall have been carried out and the test shall have been witnessed and certified by a third party inspection agency like Lloyds, BVIS, DNV, TUV or EIL/ CEIL unless otherwise specified. The vendor has to submit test certificate covering the entire range of valves to be supplied.

Vendors who do not have Fugitive emission type test certificate covering the range of valves to be supplied, shall conduct the requisite test within 12 weeks from the date of purchase order or within contractual delivery date, whichever is earlier.

In case of non-conductance of Fugitive emission type test(s) within time frame specified above or failure in the test(s) conducted after receipt of order, the owner reserves the right to invoke any of the provisions of the purchase order including cancellation of the purchase order at the risk and cost of vendor.

3.28 Valves specified as LO (Lock open) and LC (Lock closed) shall be supplied with suitable arrangement for locking in open as well as in closed position. Lock is included in vendor's scope of supply.

3.29 For Lugged Wafer Type (WAFL) Butterfly Valves, lug shall be provided for each bolt.

3.30 For butterfly valves, where bolting for tapped hole in body is being supplied by Vendor and diameter of the bolting is more than or equal to 1", the bolting supplied shall be studs to ASME B18.2.1 with two nuts.

3.31 For Gate and Globe valves, the stem surface area in contact with the packing shall have a surface finish, Ra, of 0.80µm (32µin.) or smoother, unless otherwise specified.

4.0 OPERATION

4.1 Gear operation shall be provided as under as a minimum, unless otherwise specified:

Valve Type	Class	Size Requiring Gear-Operator
Gate Valve, Globe Valve & Diaphragm Valve	150 Class	12" and larger
	300 Class	12" and larger
	600 Class	10" and larger
	900 Class	6" and larger
	1500 Class	3" and larger
	2500 Class	3" and larger
Ball Valve / Plug Valve (Other than pressure balance plug valves)	150 Class	6" and larger
	300 Class	6" and larger
	600 Class	4" and larger
Ball Valve / Plug Valve (Other than pressure balance plug valves)	900 Class	3" and larger
	1500 Class	3" and larger
Butterfly Valve	150, 300 Class	6" and larger

For sizes lower than these ranges, hand wheel / lever / wrench shall be provided. For pressure balance plug valves manufacturer's recommendation shall be acceptable provided the requirements specified in clause 4.6 are met.

- 4.2 Gear operator shall be provided, with position indicators for open / close positions and with limit stops. (Limit stops are not applicable for gate valves). Gear box shall be fully encased and weather proof.
- 4.3 Where gear operator is not called for as per Clause 4.1 but vendor recommends a gear operator, the same shall be highlighted.
- 4.4 Gear operator shall be so designed as to operate effectively with the differential pressure across the closed valve equal to the cold non-shock pressure rating.
- 4.5 Ball, plug and butterfly valves, shall have "Open" position indicators with limit stops.
- 4.6 Hand-wheel diameter shall not exceed 750mm and lever length shall not exceed 500mm on either side. Effort to operate shall not exceed 35 Kg at hand-wheel periphery. However, failing to meet the above requirements, vendor shall offer gear operated valve and quote as per clause 4.3.

5.0 INSPECTION AND TESTING

- 5.1 Every valve shall be subjected to all the mandatory tests and checks called in the respective codes / data sheet by EIL inspection or any third party as approved by the purchaser. For IBR valves refer clause 7.0.
- 5.2 Every valve, its components and auxiliaries must be subjected to all the mandatory tests and checks called for in the respective codes, data sheets etc. by the manufacturer.
- 5.3 Though the extent of inspection shall be as under, exact extent with hold points shall be decided by EIL regional inspection office and recorded in the form of inspection plan. In case of third party inspection, the inspection plan shall be approved by the purchaser.

Forged Valves:

1. Visual and dimensional inspection.
2. Review of material test certificates.
3. Any mandatory or supplementary test.
4. Hydrostatic test on 10% valves selected on random basis.
5. Strip check is required for 1% of total ordered quantity of Gate & Globe valves (min. 1 No.) for each Valve sheet no., however, strip check is not required for CS/ Brass/ Bronze material valves with 13% Cr/ Brass/ Bronze trims.
6. Type test certificate for Fugitive Emissions as per Cl. 3.27.3.
7. Positive Material Identification
8. Type test certificates for cryogenic & Fire safe test to be submitted.

Cast Steel Valves:

1. Visual inspection with acceptance standards as per MSS SP-55 and dimensional inspection.
2. Review of material test certificates.

3. Review of radiographs and radiographic reports or any other NDT tests wherever applicable as per data sheet.
4. Any mandatory or supplementary test.
5. Hydrostatic test 100% for body, 10% other test.
6. Strip check is required for 1% of total ordered quantity of Gate & Globe valves (min. 1 No.) for each Valve sheet no., however, strip check is not required for CS/ Brass/ Bronze material valves with 13% Cr/ Brass/ Bronze trims.
7. Type test certificate for Fugitive Emissions as per Cl. 3.27.3.
8. Positive Material Identification
9. Type test certificates for cryogenic & Fire safe test to be submitted.

Samples for strip check shall be selected at random and shall generally be in the highest size in the lot.

- 5.4 In case of motor operated or actuator operated valves, functional / operational checks as per the requirements of the specifications shall be made on each valve.

6.0 RADIOGRAPHY OF CAST VALVES

- 6.1 Valve castings shall undergo radiographic examination as specified below.

Material	Rating	Size Range	Radiography
All	Class 150	24" and below	NIL**
		26" and above*	100%
	Class 300	16" and below	NIL**
		18" and above	100%
	Class 600& above	All sizes	100%

* No radiography is required for valves of size 26" and above in cooling water service.

**For sizes 24" & below in Class 150 and 16" & below in Class 300, radiography percentage if specifically mentioned in individual valve material spec sheet shall govern.

Radiography specified as random 10% or 20% etc. in the respective valve data sheet implies 10% or 20% etc. of number of valves ordered against each item number with a minimum of one valve against each item.

- 6.2 Radiography procedure, areas of casting to be radiographed shall be as per ASME B16.34 and acceptance criteria shall be as per ASME B16.34. However for areas of casting to be radiographed for types of valves not covered in ASME B16.34, vendor shall radiograph castings in line with ASME B16.34.
- 6.3 For random radiography wherever specified in individual data sheets, the sampling shall be per size of the quantity ordered for each foundry.
- 6.4 Radiography wherever specified in the data sheets or as per clause 6.1 shall be done by X-ray / γ -ray to get the required sensitivity.

7.0 IBR CERTIFICATION

7.1 For valves described "IBR", valves shall be in accordance with the latest IBR (Indian Boiler Regulation) including the requirements specified in the specification.

7.2 For SW / BW end carbon steel valves under IBR, the chemical composition shall conform to the following:

Carbon (Max)	:	0.25%
Others (S, P, Mn)	:	As per IBR

7.3 Valves coming under the purview of "IBR" (Indian Boiler Regulations) shall each be individually accompanied by IBR certificate original in Form III-C duly approved by IBR authority / local authority empowered by the Central Boiler Board of India. Photocopy of original certificate duly attested by the local boiler inspector where the supplier is located is the minimum requirement for acceptance.

7.4 All "IBR" valves shall be painted red in body-bonnet / body-cover joint.

8.0 MARKING

8.1 Valve markings, symbols, abbreviations etc. shall be in accordance with MSS-SP-25 or the standard referred in specification sheet as applicable. Vendor's name, valve rating, material designation, nominal size, direction of flow (if any) etc. shall be integral on the body.

8.2 Each valve shall have a corrosion resistant tag giving size, valve tag / code no., securely attached to the valve body.

8.3 Paint or ink for marking shall not contain any harmful metal or metal salts such as zinc, lead or copper which cause corrosive attack on heating.

8.4 Carbon Steel / Alloy Steel valves shall be painted with one coat of inorganic zinc silicate (minimum DFT 65 to 75 microns).

9.0 DESPATCH

9.1 Valve shall be dry, clean and free from moisture, dirt and loose foreign materials of any kind.

9.2 Valves shall be protected from rust, corrosion and any mechanical damage during transportation, shipment and storage.

9.3 Rust preventive on machined surfaces to be welded shall be easily removable with a petroleum solvent or shall not be harmful to welding.

9.4 Each end of valve shall be protected with the following materials:

Flange Face	:	Wood or Plastic Cover
Bevelled End	:	Wood or Plastic Cover
SW & SCRD. End	:	Plastic Cap

9.5 End protectors of wood / plastic to be used on flange faces shall be attached by at least three bolts and shall not be smaller than the outside diameter of the flange. However, plastic caps for SW & SCRD end valves shall be press fit type.

9.6 End protectors to be used on bevelled end shall be securely and tightly attached.

9.7 For special service valves additional requirement for despatch shall be as prescribed in data sheet.

10.0 ATTACHMENTS

6-44-0052-A1	:	Bypass Piping Arrangement
6-44-0052-A2	:	Specifications for Bypass Piping, Fittings and Valves
6-44-0052-A3	:	Special Requirements for Low Temperature and Cryogenic Valves
6-44-0052-A4	:	Special Requirements for Hydrogen Service Valves

11.0 REFERENCES

6-78-0001	:	Specification for Quality management system requirements from bidders
6-78-0003	:	Specification for documentation requirements from suppliers
6-81-0001	:	Specification for Positive Material Identification (PMI) at Supplier's Works
6-81-0004	:	Inspection and Test plan for Valves

BYPASS PIPING ARRANGEMENT

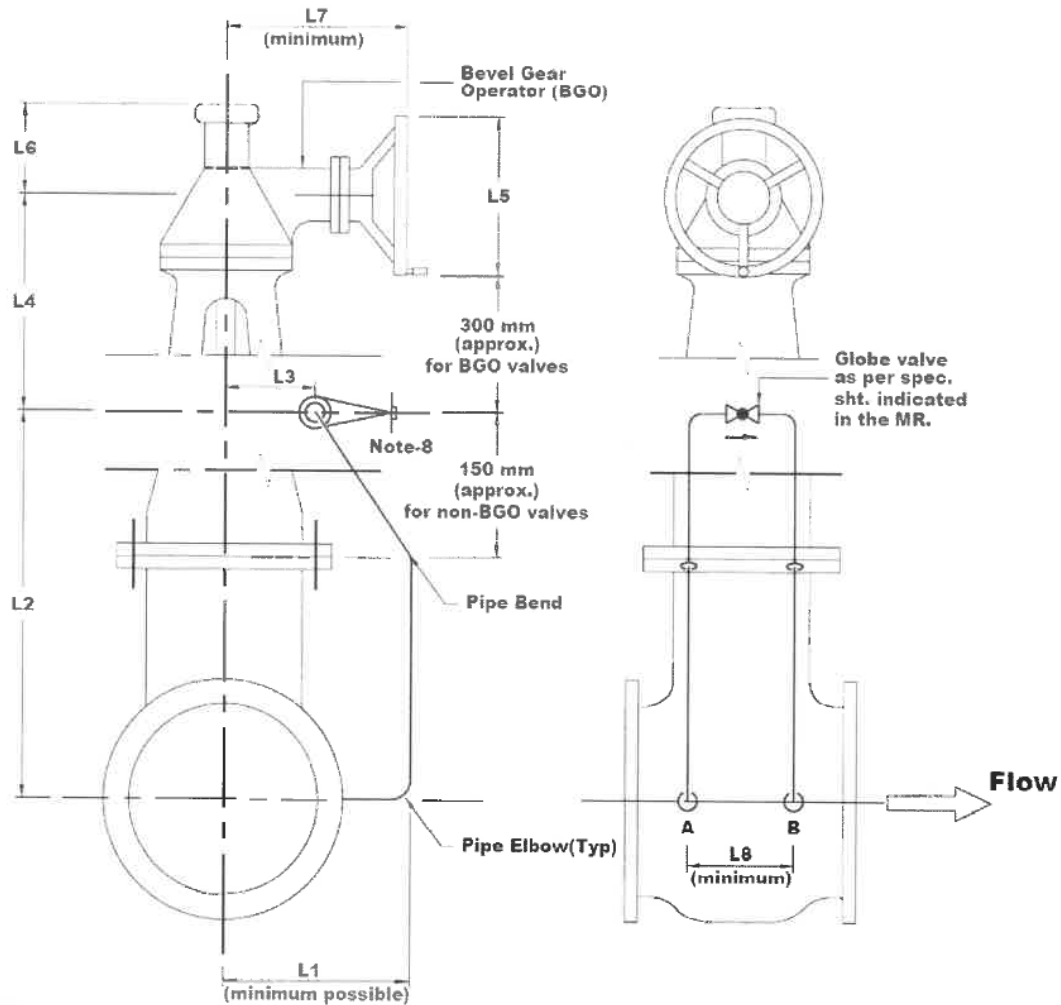

NOTES:

1. The orientation & location of handwheel of bevel gear operator & the bypass arrangement shall be strictly as per this sketch.
2. The bypass connection ends including connection to boss in main valve body shall be socket welded upto 600# and butt welded for 900# and above rating.
3. The bypass arrangement shall be properly clamped to & supported by the body of the main valve.
4. Basic design of bypass shall be to MSS-SP-45.
5. Material of bypass pipe & 90° elbows shall be same or equivalent to the body material as indicated in Specification No. 6-44-0052-A2.
6. This sketch is applicable for both BGO & NON-BGO Valves.
7. Vendor shall furnish dimensions L1 to L8.
8. Stem shall not be horizontal in the case of CRYO Valves.

SPECIFICATIONS FOR BYPASS PIPING, FITTINGS AND VALVES

Class (Main Valve Sht.no.)	Pipe	Fittings	Bypass Valve Sht.no.	Remarks
A1A(51301), A3A(51321), A39A (51321), A9A(51301), A11A(51301), A33A(51301), B1A(51401), B9A(51401), D1A(51501), D9A (51501)	ASTM A106 Gr.B (SMLS) 0.5"-1.5": S160	ASTM A105 0.5"-1.5": SW 6000#	52001	
A6A(51301), B6A(51401)	ASTM A106 Gr.B (SMLS) 0.5"-0.5" : XXS 0.75"-1.5": S160	ASTM A105 0.5"-0.5" : SW 9000# 0.75"-1.5": SW 6000#	52001	
A13A(51301), B13A(51401)	ASTM A106 Gr.B (SMLS) 0.5"-1.5" : XXS	ASTM A105 0.5"-1.5" : SW 9000#	52001	
A2A(51302), B2A(51402), D2A (51502)	ASTM A106 Gr.B (SMLS)- IBR 0.5"-0.75": S160 1.0"-1.5" : XS	ASTM A105 - IBR 0.5"-0.75": SW 6000# 1.0"-1.5" : SW 3000#	52002	
A4A (51303), B4A (51403), D4A (51503)	ASTM A333 Gr.6 (SMLS)- LT 0.5"-0.75": S160 1.0"-1.5" : XS	ASTM A350Gr.LF2CL.1-LT 0.5"-0.75": SW 6000# 1.0"-1.5" : SW 3000#	52003	
B5A (51404), D5A (51504)	ASTM A106 Gr.B (SMLS) -H2 0.5"-0.75": S160 1.0"-1.5": XS	ASTM A105 - H2 0.5"-0.75": SW 6000# 1.0"-1.5" : SW 3000#	52004	Note-1
A7A (51307)	ASTM A106 Gr.B (SMLS) 0.5"-0.75" : S160 1.0"-1.5": XS	ASTM A105 0.5"-0.75": SW 6000# 1.0"-1.5" : SW 3000#	52007	
A16A (51311), B16A (51411), D16A (51511)	ASTM A106 Gr.B (SMLS) - NACE 0.5"-0.75" : XXS 1.0"-1.5": S160	ASTM A105 - NACE 0.5"-0.75" : SW 9000# 1.0"-1.5": SW 6000#	52011	Note-1
A19A (51313), B19A (51413), D19A (51513)	ASTM A106 Gr.B (SMLS) 0.5"-1.5" : S160	ASTM A105 0.5"-1.5": SW 6000#	52013	Note-1
E1A (51601), F1A (51701)	ASTM A106 Gr.B (SMLS) 0.5"-1.5" : S160	ASTM A234 Gr.WPB/ ASTM A105 0.5"-1.5" : BW, S160	52101	
E2A (51602), F2A (51702)	ASTM A106 Gr.B (SMLS) - IBR 0.5"-1.5" : S160	ASTM A234 Gr.WPB/ ASTM A105 - IBR 0.5"-1.5" : BW, S160	52102	
E5A (51604), F5A (51704)	ASTM A106 Gr.B (SMLS) - H2 0.5"-1.5" : S160	ASTM A234 Gr.WPB/ ASTM A105 - H2 0.5"-1.5" : BW, S160	52104	Note-1
E9A (51605), F9A (51705)	ASTM A106 Gr.B (SMLS) 0.5"-1.5" : SCH XXS	ASTM A234 Gr.WPB/ ASTM A105 0.5"-1.5" : BW, SCH XXS	52105	

Class (Main Valve Sht.no.)	Pipe	Fittings	Bypass Valve Sht.no.	Remarks
E19A (51613), F19A (51713)	ASTM A106 Gr.B (SMLS) 0.5"-1.5" : SCH XXS	ASTM A234 Gr.WPB/ ASTM A105 0.5"-1.5" : BW, SCH XXS	52113	Note-1
A5Y (51384), A33Y (51384)	ASTM A106 Gr.B (SMLS) 0.5"-0.75" : S160 1.0"-1.5": XS	ASTM A105 0.5"-0.75": SW 6000# 1.0"-1.5" : SW 3000#	52085	
B1D (51430), D1D (51530)	ASTM A335Gr.P11(SMLS) 0.5"-0.75" : S160 1.0"-1.5": XS	ASTM A182 Gr.F11Cl.2 0.5"-0.75": SW 6000# 1.0"-1.5" : SW 3000#	52030	
D2D (51531)	ASTM A335Gr.P11 (SMLS) - IBR 0.5"-0.75" : S160 1.0"-1.5": XS	ASTM A182 Gr.F11Cl.2 - IBR 0.5"-0.75": SW 6000# 1.0"-1.5" : SW 3000#	52031	Note-1
B5D (51432), D5D (51532)	ASTM 335Gr.P11(SMLS)- H2 0.5"-0.75" : S160 1.0"-1.5": XS	ASTM A182 Gr.F11Cl.2 - H2 0.5"-0.75": SW 6000# 1.0"-1.5" : SW 3000#	52032	Note-1
B1E (51433)	ASTM A335Gr.P22(SMLS) 0.5"- 0.75" : S160 1.0"-1.5": XS	ASTM A182 Gr.F22Cl.3 0.5"-0.75": SW 6000# 1.0"-1.5" : SW 3000#	52033	
D5E (51534)	ASTM A335Gr.P22(SMLS) - H2 0.5"-0.75" : S160 1.0"-1.5": XS	ASTM A182 Gr.F22Cl.3 - H2 0.5"-0.75": SW 6000# 1.0"-1.5" : SW 3000#	52034	Note-1
A4F (51336), B4F (51436)	ASTM A335 Gr.P5(SMLS) 0.5"-0.75" : S160 1.0"-1.5": XS	ASTM A182 Gr.F5 0.5"-0.75": SW 6000# 1.0"-1.5" : SW 3000#	52036	Note-1
B3F (51436)	ASTM A335 Gr.P5(SMLS) 0.5"-1.5" : XXS	ASTM A182 Gr.F5 0.5"-1.5" : SW 9000#	52036	Note-1
A4G (51339), B4G (51439)	ASTM A335 Gr.P9(SMLS) 0.5"-0.75" : S160 1.0"-1.5": XS	ASTM A182 Gr.F9 0.5"-0.75": SW 6000# 1.0"-1.5" : SW 3000#	52039	Note-1
F2D (51731)	ASTM A335 Gr.P11 (SMLS) - IBR 0.5"-1.5" : S160	ASTM A234Gr.WP11Cl.1/ A182 Gr.F11Cl.2 - IBR 0.5"-1.5" : BW, S160	52131	Note-1
F2G (517GG)	ASTM A335 Gr.P91 (SMLS) - IBR 0.5"-0.75" : S160 1.0"-1.5": XS	ASTM A234Gr.WP91/ A182 Gr.F91 - IBR 0.5"-0.75" : S160 1.0"-1.5": XS	52140	Note-1
G2G (518GG)	ASTM A335 Gr.P91 (SMLS) - IBR 0.5"-1.0" : S160 1.5"-1.5": XXS	ASTM A234Gr.WP91/ A182 Gr.F91 - IBR 0.5"-1.0" : S160 1.5"-1.5": XXS	52240	Note-1
E5E (51634)	ASTM A335 Gr.P22(SMLS) - H2 0.5"-0.75" : S160 1.0"-1.5": XS	ASTM A234Gr.WP22Cl.1/ A182 Gr.F22Cl.3 - H2 0.5"-0.75" : BW, S160 1.0"-1.5" : BW, XS	52134	Note-1

Class (Main Valve Sht.no.)	Pipe	Fittings	Bypass Valve Sht.no.	Remarks
A1K (51345), A3K (51345), B1K (51445), D1K (51545)	ASTM A312TP304(SMLS) 0.5"-0.75" : 80S 1.0"-1.5": 40S	ASTM A182 Gr.F304 0.5"-1.5" : SW 3000#	52045	
A2K (51346), B2K (51446), D2K (51546)	ASTM A312TP304(SMLS) - CRYO 0.5"-0.75" : 80S 1.0"-1.5": 40S	ASTM A182 Gr.F304 - CRYO 0.5"-1.5" : SW 3000#	52046	
B4K (51448), B5K (51448)	ASTM A312TP304H(SMLS) 0.5"-1.5" : 80S	ASTM A182 Gr.F304H 0.5"-1.5": SW 3000#	52048	
A6K (51350), A11K (51350), B6K (51450)	ASTMA312TP304L(SMLS) 0.5"-0.75" : 80S 1.0"-1.5": 40S	ASTM A182 Gr.F304L 0.5"-1.5": SW 3000#	52050	
A1M (51361), B1M (51461)	ASTM A312 TP316(SMLS) 0.5"-0.75" : 80S 1.0"-1.5": 40S	ASTM A182 Gr.F316 0.5"-1.5": SW 3000#	52061	
B5M (51462)	ASTMA312TP316H(SMLS) - H2 0.5"-0.75" : 80S 1.0"-1.5": 40S	ASTM A182 Gr.F316H - H2 0.5"-1.5": SW 3000#	52062	
B3M (51463)	ASTM A312 TP321(SMLS) 0.5"-0.75" : 80S 1.0"-1.5": 40S	ASTM A182 Gr.F321 0.5"-1.5": SW 3000#	52063	
A1N (51366), B1N (51466)	ASTMA312TP316L(SMLS) 0.5"-0.75" : 80S 1.0"-1.5": 40S	ASTM A182 Gr.F316L 0.5"-1.5": SW 3000#	52066	
B6N (51471)	ASTM A312 TP316L (SMLS) 0.5"-0.75" : 80S 1.0"-1.5": 40S	ASTM A182 Gr.F316L 0.5"0.5"-1.5": SW 3000#	52071	

In case specifications for bypass of any specific VMS sheets are not available in the MR, Vendor to obtain the same from EIL and supply strictly in line with specifications.

Notes:

1. All welded joints shall be post weld heat treated. Procedure for Post weld heat treatment shall be in accordance with ASME B31.3.

SPECIAL REQUIREMENTS FOR LOW TEMPERATURE & CRYOGENIC VALVES

1.0 SCOPE

All valves of Low Temperature Carbon Steel (LTCS) and all grades of austenitic SS (CRYO) material are categorized as cryogenic valves. All these valves shall have extended bonnet. The bonnet extension shall be as per VMS sheets (BS 6364/ BS EN ISO 28921-1) except check valves.

2.0 QUALIFICATION CRITERIA

For Limited Enquiries (Non NIT enquiries)

- 2.1 Vendors who satisfy both the requirements given below shall be considered qualified :
 - a. Vendor should be enlisted with EIL for any cryogenic valve irrespective of type, size, rating and metallurgy
 - b. Vendors should be enlisted with EIL for the same type, material, size and rating of non-cryogenic/cryogenic valve as the cryogenic valve quoted for
- 2.2 Qualified Vendors who do not have cryogenic test reports covering the range of Cryogenic valves quoted for, shall conduct cryogenic test per clauses 3.0 within 12 weeks from the date of purchase order.
- 2.3 Clauses 2.1 and 2.2 of this Annexure shall be read in conjunction.

3.0 CRYOGENIC TEST

3.1 Vendors to furnish copies of cryogenic test certificate for tests as per details given below:

- 3.1.1 Test shall be as per VMS sheets (BS 6364/ BS EN ISO 28921-2).
- 3.1.2 Test temperature, unless specifically called for otherwise in the individual MR, shall be -45°C for LTCS and -196°C for all grades of austenitic stainless steel.
- 3.1.3 Tests carried out on a particular size of one type of valve, pressure rating and material shall qualify all sizes equal to and below the test valve size for the same type, pressure rating and material. In case of austenitic SS any one grade would qualify for all other grades of austenitic SS.
- 3.1.4 Tests should have been witnessed and certified by any third party inspection agencies like M/s Lloyd, BV, DNV, TUV or EIL/ CEIL.
- 3.1.5 Test conducted previously and witnessed by inspection agencies listed above shall be considered acceptable and need not be repeated.

3.2 Post Order Testing Procedure

- 3.2.1. Before conducting post order testing, vendor shall obtain approval for the following from TPIA:

a. Test procedure and Schematic of test rig with complete details as per standard specified in VMS sheet (BS 6364/ BS EN ISO 28921-2).

b. Cross-section drawing of the valve with material of construction.

3.2.2. Test has to be conducted irrespective of the service on largest size for each type of valve and for each material and class rating. Vendor shall offer one, two or three valves for selection of test valve by inspector depending upon whether quantity of largest valve in the order is one, two or three and more than three respectively.

In the event of failure of the test valve to meet the specification requirements, the vendor shall conduct test on two more valves. These two valves which pass test successfully, are of lower size, then the qualification will be valid only to sizes upto which test has been conducted successfully.

3.2.3. In case of non-conductance of cryogenic test(s) within 12 weeks or failure in the test(s) conducted after receipt of order, the owner reserves the right to invoke any of the provisions of the purchase order including cancellation of the purchase order at the risk and cost of vendor.

4.0 Bonnet extension, wherever specified in the valve sheet shall be for “non cold box application” unless otherwise specified in the MR. Even if not called for in VMS, valves indicated as “LT” or “CRYO” shall be supplied with bonnet extension.
If the valves are supplied in accordance with BS EN ISO 28921-1, Bonnet extension in LT service shall be as per values specified for -51 Deg.C to -109 Deg.C.

5.0 Bonnet and Gland extension joints shall be of butt welded/integrally cast construction.

6.0 Repair welding procedure for austenitic stainless steel valves in “CRYO” service shall have to be qualified for impact test as per ASME B31.3. Minimum acceptable impact energy shall be 20 J or lateral expansion of 0.38 mm at temperature of -196°C.

7.0 Wherever impact test of SS studs / nuts is called for in the data sheet, the impact value shall be 27 J at the intended service temperature specified in the data sheets.

SPECIAL REQUIREMENTS FOR HYDROGEN SERVICE

1.0 GENERAL

- 1.1 These requirements are applicable for valves used in Hydrogen service. These are in addition to the requirements described in "Technical Notes for Valves" Spec. No. 6-44-0052, and shall be read in conjunction with this specification.
- 1.2 All cast valve flanges & bodies with flange rating of Class 900 or greater shall be examined in accordance with paragraphs 7.2 through 7.5 of Appendix-VII of ASME SEC-VIII, DIV.1, regardless of casting quality factor.
- 1.3 Body / bonnet / cover joints & stuffing box of all valves shall have low emission. One valve per metallurgy, per rating, per size shall be helium leak tested as per ASME Sec.V, Subsection A, Article 10 (Detector Probe Technique), Appendix IV at a minimum of 25% of the allowable (rated) cold working pressure. Selection of valves for helium leak test shall be at random. Test duration shall be as follows:

Test Duration in Minutes					
Nominal Size	Pressure Class				
	Upto 300	600	800 & 900	1500	2500
Upto 2"	3	6	9	12	12
3" to 6"	6	9	12	15	18
8" to 16"	9	9	12	15	18
18" to 24"	9	12	15	18	21

The valve shall show no leakage. No leakage is defined as a total leakage rate of less than 0.0001 ml/s of helium.

- 2.0 Only normalized and tempered material shall be used in the following specifications:

Castings : A217 Gr.WC1, A217 Gr.WC4, A217 Gr.WC5, A217 Gr.WC6, A217 Gr.WC9, A217 Gr.C5, A217 Gr.C12

Forgings : A182 Gr.F11 Cl.2

3.0 CS & AS VALVES

- 3.1 Bend test and Magnetic Particle inspection of the entire surface of body and bonnet casting shall be in accordance with ASTM A217. Supplementary requirement S3 & S4 evaluation of magnetic particle, inspection shall be in accordance with MSS-SP-53 except that no linear discontinuities shall be allowed.
- 3.2 The Brinell hardness of heat treated casting shall not exceed 200 BHN for carbon steel & 225 BHN for alloy steel.
- 3.3 Repair to defective casting shall be outlined in writing to the purchaser before repair starts. Repair method to be approved prior to welding.
- 3.4 Casting shall be preheated to a minimum of 400°F prior to welding and all Chromium-Molybdenum alloys shall be postweld heat treated after welding is complete. Stress relieving is essential for welds.

- 3.5 Carbon steel shall be normalised and alloy steels shall be normalised & tempered.
- 3.6 Dye Penetrant test of welds shall be in accordance with ASTM B165 Procedure B-2. Interpretation as per Appendix-8 of ASME-VIII Div.1.
- 3.7 The tensile stress for AS shall be less than 100,000 psi.
- 3.8 Charpy V-notch impact testing is to be done for valve material (average 20 ft-lb for set of 3 [minimum value 15 ft-lb] at 30°F).
- 3.9 For radiography and acceptance criteria for valve castings, refer Cl. 4.2.
- 4.0 **SS VALVES**
- 4.1 Valve casting shall be in solution heat treated and pickled condition.
- 4.2 Critical body and bonnet casing section typically defined by ASME B16.34 shall be radiographed and shall meet ASTM E446 (upto 2" thick) Category A, B & CA Level 2, Category CB, OC & CD Level 3, Category D, B & F Level 0. For wall thickness 2" to 4.5" comparable plates of ASTM E186 shall be used. ASTM E94 and ASTM E142 shall be used for recommended practice & controlling quality of radiography as guide. The entire surface of all castings shall be dye-penetrant inspected after pickling.
- 4.3 Repair Welds shall be 100% radiographed and evaluated in accordance with paragraph 344.5 of ASME B31.3 with a minimum casting quality factor of 0.95. Dye Penetration test shall be as per ASTM E165 Procedure B-2, Interpretation as per Appendix-8 of ASME-VIII Div.1.

वाल्वों के लिए
निरीक्षण एवं परीक्षण योजना

INSPECTION AND TEST PLAN
FOR
VALVES

Rev. No.	Date	Purpose	Prepared by	Checked by	Standards Committee Convenor	Standards Bureau Chairman
7	08.05.2023	REVISED AND RE-ISSUED	NK	AK	RK	SM
6	14.11.2018	REVISED AND RE-ISSUED	KC	NM	RKS	RKT
5	17.06.2013	REVISED AND RE-ISSUED	TKK	RKS	SCG	DM
4	15.07.2011	REVISED AND RE-ISSUED	TKK	SCG	AKC	DM
3	30.06.2010	REVISED AND RE-ISSUED	RKB	VKJ	SKP	ND
2	31.01.2008	REVISED AND RE-ISSUED	CS	SS	MVKK	VC
			Approved by			

Abbreviations:

CEIL	:	Certification Engineers International Limited	MRT	:	Mechanical Run Test
CIMFR	:	Central Institute of Mining & Fuel Research	NDT	:	Non Destructive Testing
CE	:	Carbon Equivalent	NPSH	:	Net Positive Suction Head
DFT	:	Dry Film Thickness	PO	:	Purchase Order
DPT	:	Dye Penetrant Testing	PESO	:	Petroleum Explosive Safety Organization
DHT	:	De-hydrogen Heat Treatment	PQR	:	Procedure Qualification Record
ERTL	:	Electronics Regional Test Laboratory	PR	:	Purchase Requisition
FCRI	:	Fluid Control Research Institute	PMI	:	Positive Material Identification
HT	:	Heat Treatment	RT	:	Radiography Testing
HIC	:	Hydrogen Induced Cracking	SSCC	:	Sulphide Stress Corrosion Cracking
ITP	:	Inspection and Test Plan	TC	:	Test Certificate
IP	:	Ingress Protection	TPI or TPIA	:	Third Party Inspection Agency
IHT	:	Intermediate Heat Treatment	UT	:	Ultrasonic Testing
IC	:	Inspection Certificate	VDR	:	Vendor Data Requirement
IGC	:	Inter Granular Corrosion	WPS	:	Welding Procedure Specification
MPT/MT	:	Magnetic Particle Testing	WPQ	:	Welders Performance Qualification
MTC	:	Material Test Certificate			

Inspection Standards Committee

Convenor : Mr. Rajeev Kumar

Members:

Mr. Rajesh Sinha
Mr. Avdhesh Agrawal

Mr. Himangshu Pal
Mr. Mahendra Mittal

Mr. Chandrashekhar
Ms Sulakshna Hundekari
(Piping)

Mr. R Muthu Ramalingam (RPO Rep.)

1.0 SCOPE

This Inspection and Test Plan covers the minimum testing requirements of Valves.

2.0 REFERENCE DOCUMENTS

PO/PR/Standards referred therein/ Job specifications /Approved documents.

3.0 INSPECTION AND TEST REQUIREMENTS

SL NO	STAGE / ACTIVITY	CHARACTERISTICS	QUANTUM OF CHECK	RECORD	SCOPE OF INSPECTION		
					SUB SUPPLIER	SUPPLIER	EIL/TPIA
1.0	Procedure						
1.1	Hydrostatic Test, Heat Treatment, NDT, Helium Leak Test, Fugitive Emission Test, Internal/ External Coating Procedures & Other Procedures (Wherever applicable, as per MR/ PR)	NDT Level III Approved Documented Procedures	100%	NDT Level III Approved Procedure Documents	-	H	R
1.2	WPS, PQR & WPQ and NDT operator Qualification Record	Welding Parameters & Qualification Record	100%	WPS, PQR & WPQ	-	H	W- New R- Existing

INSPECTION AND TEST PLAN
FOR
VALVES

SL NO	STAGE / ACTIVITY	CHARACTERISTICS	QUANTUM OF CHECK	RECORD	SCOPE OF INSPECTION		
					SUB SUPPLIER	SUPPLIER	EIL/TPIA
1.3	Pre-Qualification Tests	Fire safe, Cryogenic, Fugitive Emission Test, Internal Epoxy Coating, Glass Lined Coating & Other Test as applicable	As per PR / Purchase Specification	Acceptance Report	-	H	H (If new)
2.0	Material Inspection						
2.1	Castings & Forgings (Body, Bonnet, Disc, Stem, Body ring)	Chemical, Mechanical (Tensile, Hardness, Impact Test etc.), Heat Treatment, NDT, IGC & Other Properties as applicable	100%	Test Certificates	H	R	R
2.2	Castings & Forgings (Body, Bonnet, Disc, Stem, Body ring)	Visual & Dimension	100%	Inspection Report	H	H	-
2.3	Body and Bonnet Castings	Radiography Examination after Heat Treatment	As per PR / Purchase Specification	RT Films and NDT reports	H	R	R
2.4	Bars for Trim material	Chemical Analysis	Each Heat	Test Certificates & Lab Report	H	R	-

INSPECTION AND TEST PLAN
FOR
VALVES

SL NO	STAGE / ACTIVITY	CHARACTERISTICS	QUANTUM OF CHECK	RECORD	SCOPE OF INSPECTION		
					SUB SUPPLIER	SUPPLIER	EIL/TPIA
2.5	Gaskets, Gear units, Fasteners, Gland, Packings, etc.	Physical / Chemical Properties	100%	Test Certificates & Lab Report	H	R	-
2.6	Actuators as applicable	Performance, Statutory Certificates etc. As per EIL ITP. 6-81-1091	100%	Test Certificates, Inspection report	H	H	R
3.0	In Process Inspection						
3.1	Welding, Weld Overlay, Stellite, Hardfacing (As applicable)	Welding Parameters as per WPS / PQR	100%	Inspection Reports	-	H	-
3.2	Machining of components	Visual / Dimension	100%	Inspection Reports	-	H	-
3.3	DP Test for all weld joints, Bevel Ends & Bypass (as applicable)	Dye Penetrant Test	100%	NDT Report	-	H	RW
3.4	Hardness Check	Heat Treat Castings, Weld Joints, Groove Joints etc.	100%	Inspection Reports	-	H	R
4.0	Final Inspection						

INSPECTION AND TEST PLAN
FOR
VALVES

SL NO	STAGE / ACTIVITY	CHARACTERISTICS	QUANTUM OF CHECK	RECORD	SCOPE OF INSPECTION		
					SUB SUPPLIER	SUPPLIER	EIL/TPIA
4.1	a. Shell Hydrotest b. Seat Hydro Test (Both Sides) c. Backseat Hydrotest (Gate & Globe Valves) d. Seat Pneumatic/ Air Test	Leak Check	100%	Pressure Test Report, Water quality Report		H	RW (Note 1)
4.2	Helium Leak test / Vacuum Test (as applicable)	Leak Check	As per PR / Purchase Specification	Test Report	-	H	RW (Note 1)
4.3	Visual & Dimensional Check	Surface Verification & Dimension Measurement	100%	Test Report	-	H	RW (Note 1)
4.4	Functional Test for Motor/ Actuator Operated Valves	Satisfactory Performance	100%	Test Report	-	H	RW
4.5	Marking Verification	Verification of Marking, Valve Tagging & Name Plate Checking	100%	Marking & Tagging Report		H	RW (Note-1)
4.6	PMI Check	Chemical Check	As per EIL Spec. 6-81-0001	PMI Report	-	H	RW

INSPECTION AND TEST PLAN
FOR
VALVES

SL NO	STAGE / ACTIVITY	CHARACTERISTICS	QUANTUM OF CHECK	RECORD	SCOPE OF INSPECTION		
					SUB SUPPLIER	SUPPLIER	EIL/TPIA
4.7	Strip Check (As applicable)	Verify Components for wear, damage , harmful defects & Differential hardness as applicable	As per PR / Purchase Specification	Inspection Report	-	H	RW (Note-1)
4.8	Final Stamping	Stamping of Accepted Valves	Stamping of Valves which are witnessed by EIL/TPIA.	Inspection Report	-	H	H (Note-1)
5.0	Painting						
5.1	Painting/ Pickling & Passivation and Color coding as applicable	Visual / DFT Check	100%	Inspection Report	-	H	-
6.0	PACKING & PROTECTION						
6.1	Packing & Protection	Dispatch Instructions as per Technical Notes for Valves	100%	Compliance Report with photographs		H	RW
7.0	Documentation & Inspection Certificate						

SL NO	STAGE / ACTIVITY	CHARACTERISTICS	QUANTUM OF CHECK	RECORD	SCOPE OF INSPECTION		
					SUB SUPPLIER	SUPPLIER	EIL/TPIA
7.1	Documentation & Inspection Certificate (IC)	Review of Stage Inspection Reports / Test Reports & Issue of IC	100%	Supplier TC & IC	-	H	H

Legend: H- Hold (Do not proceed without approval), P-Perform, RW - Random Witness (As specified or 10% (min.1 no. of each size and type of Bulk item)), R-Review, W-Witness (Give due notice, work may proceed after scheduled date).

NOTES (As applicable):

1. Non NACE & Non Hydrogen service Carbon Steel Cast Valves up to size 12"-300ANSI Class and Carbon Steel Forged Valves up to size 1.5"- 800 ANSI Class will be accepted on review of Supplier Test Certificates.
Supplier Test Certificate along with back up reports to be reviewed by EIL/TPIA.
2. This document describes the generic test requirements. Any additional test or Inspection scope if specified in contract documents shall also be applicable. (Unless otherwise agreed upon)
3. Acceptance Norms for all the activities shall be as per PO/PR/STANDARDS referred therein /Job Specification /Approved Documents.

विक्रेता कार्यशाला में सकारात्मक सामग्री पहचान के लिए मानक विनिर्देश

STANDARD SPECIFICATION FOR POSITIVE MATERIAL IDENTIFICATION (PMI) AT SUPPLIER'S WORKS

4	23.12.21	REVISED AND RE-ISSUED	HKM	CS	RK	S Maumdar
3	19.09.16.	REVISED AND RE-ISSUED	TKK	HP	RKS	RN
2	20.10.11	REVISED AND RE-ISSUED	RKS	SCG	AKC	DM
1	15.07.08	REVISED AND RE-ISSUED	NKR	SSL	SKP	VC
0	07.12.00	ISSUED AS STANDARD SPECIFICATION	AKC	AKB	AKB	MI
Rev. No	Date	Purpose	Prepared by	Checked by	Standards Committee Convenor	Standards Bureau Chairman
						Approved by

Abbreviations:

API	:	American Petroleum Institute
AS	:	Alloy Steel
HIC	:	Hydrogen Induced Cracking
LSTK	:	Lump Sum Turn Key
NACE	:	National Association of Corrosion Engineers
PMI	:	Positive Material Identification
RTJ	:	Ring Type Joint
Sch	:	Schedule
SS	:	Stainless Steel
TPI or TPIA	:	Third Party Inspection Agency

Inspection Standards Committee

Convenor: Mr. Rajeev Kumar

Members: Mr. Rajesh Sinha
Mr. Himangshu Pal
Mr. R. Muthuramalingam (RPO Representative)
Mr. Chandrashekhar
Mr. Avdhesh Agrawal
Mr. P V Satyanarayana (Engg. Representative)
Mr. Mahendra Mittal

CONTENTS

1.0	SCOPE.....	4
2.0	REFERENCE DOCUMENTS.....	4
3.0	DEFINITIONS	4
4.0	PMI EXAMINATION	5
5.0	ACCEPTABLE METHODS FOR PMI	5
6.0	EXTENT OF PMI EXAMINATION	6
7.0	ACCEPTANCE CRITERIA.....	6
8.0	REJECTION CRITERIA.....	7
9.0	RECORDING AND DOCUMENTATION	7
10.0	MARKING	7

1.0 SCOPE

- 1.1 This specification applies to the requirements for Positive Material Identification (PMI) to be performed at the Supplier's works on Metallic Materials procured either directly by the Owner/EIL/ LSTK contractor or indirectly through the sub-Suppliers.
- 1.2 This specification covers the procedures and methodology to be adopted to assure that the chemical composition of the material is consistent with the material specifications as specified in purchase documents using 'Alloy Analyzer' at the time of final inspection before dispatch.
- 1.3 The scope of this specification shall include but shall not be limited to Positive Material Identification (PMI) to be performed on Materials listed below:
- 1.3.1 For alloy Steel materials as below:
- Alloy Steel Pipes including Clad Pipes
 - Alloy Steel Flanges & Forgings
 - Alloy Steel Fittings including Clad Fittings
 - Alloy Steel Fasteners
 - Alloy Cast & Forged steel valves
 - Alloy Steel Instrumentation Items (Control Valves, Safety Valves etc.)
 - Longitudinal Pipe & Fittings Welds.
 - Gaskets (for Ring Type Joints)
- 1.3.2 For Carbon Steel materials as below:
- All Carbon Steel Piping items under NACE or HIC or H₂ or Wet Hydrogen Sulfide (H₂S), Hydrofluoric acid (HF), Sulfuric acid (H₂SO₄) services etc.
 - Carbon Steel flanges and valves (Rating 900# and above)
 - LTCS items

Following items shall be excluded from scope of PMI examination.

- Gaskets other than for Ring Type Joints
 - Internal Components of Valves
- 1.4 All grades of material supplies including Stainless Steels shall be liable for PMI test at site. In case of any defective materials being found at site, the Supplier shall be responsible to effect replacement of such defective materials at project site without any delays to the satisfaction of EIL site RCM (Resident Construction Manager).

2.0 REFERENCE DOCUMENTS

- 2.1 API Recommended Practice 578 (Third Edition, Feb 2018) - Material Verification Program for New and Existing Alloy Piping Systems.

3.0 DEFINITIONS

- 3.1 **Supplier:** Any Supplier or Manufacturer on whom an order is placed for the supply of referred items. This definition shall also include any sub-Supplier or manufacturer on whom a sub-order is placed by the Supplier.
- 3.2 **Inspection Lot:** A group of items offered for inspection covered under same size, Heat and Heat treatment lot.

3.3 **Alloy Material:** Any metallic material (including welding filler materials) that contains alloying elements such as Chromium, Nickel, Molybdenum or Vanadium, which are intentionally added to enhance mechanical or physical properties and/or corrosion resistance.

4.0 PMI EXAMINATION

4.1 The Supplier shall submit a procedure of PMI to comply with the requirements of this Specification. Approval of PMI Procedure shall be obtained from Owner / EIL / TPIA prior to commencing manufacture / inspection of product.

4.2 PMI examination of materials is independent of any certification, markings or colour coding that may exist and is aimed at verifying that the alloy used are as per specified grades.

4.3 The Supplier shall identify all incoming alloy materials and maintain full traceability of all alloy materials, including all off-cuts. Transfer of identification marks shall be undertaken prior to cutting to ensure maintenance of identification on off-cuts.

4.4 The Supplier shall ensure that all alloy materials are segregated and stored in separately identified locations to prevent the mix up of materials of different alloy specifications or alloy material with carbon steel. Non ferro-magnetic materials shall be segregated at all times from ferro-magnetic materials.

4.5 PMI examination is subject to surveillance inspection by Owner / EIL / TPIA.

5.0 ACCEPTABLE METHODS FOR PMI

5.1 The method used for PMI examination shall provide a quantitative determination of the alloying elements like Chromium, Nickel, Molybdenum or Vanadium in Alloy Steel items.

5.2 Instruments or methods used for PMI examination shall be able to provide quantitative, recordable, elemental composition results for positive identification of alloying elements present.

5.3 The acceptable instruments for alloy analyzer shall be either "Portable X-Ray fluorescence" or "Optical Emission" type each capable of verifying the percentage of alloy elements within specified range.

5.4 Chemical spot testing, magnets, alloy sorters and other methods using eddy current or triboelectric testing methods are not acceptable for PMI examination.

5.5 The PMI instrument used shall have the sensitivity to detect the alloying elements in the specified range.

5.6 All PMI instruments shall have been serviced within a 6 month period of the time of use to verify the suitability of batteries, sources etc., and the data of the last service shall be stated on the PMI Report Form (Sample enclosed).

5.7 Each analyzer must be calibrated according to the manufacturer's specification at the beginning and end of each shift. Instrument must be checked against known standard for each alloy type to be inspected during the shift.

5.8 Certified samples, with full traceability, of a known alloy materials shall be available for use as a random spot check on the instrument calibration.

- 5.9 The surfaces to be examined shall be prepared by light grinding or abrasive paper and solvent cleaner. Evidence of Arc burn resulting from examination shall be removed by light grinding or abrasive paper. No permanent marks, which are injurious to the usage of product in service, are acceptable.
- 5.10 Alloy Steel ring type joint Gaskets shall be inspected by using portable X-Ray fluorescence instrument.
- 5.11 Testing shall be done as per the procedures outlined by the manufactures of alloy analyzer being used. Modification of these procedures if any must be approved by Owner/EIL.
- 5.12 The persons performing PMI shall demonstrate their capabilities to the satisfaction of Owner/EIL/TPIA visiting engineer. If the Supplier has qualified operator on their rolls, he may perform the examination. Otherwise PMI examination shall be sub-contracted to an independent testing agency approved by EIL.
- 5.13 Whenever material is identified as not meeting requirements by the visiting engineer a rejection note shall be issued.

6.0 EXTENT OF PMI EXAMINATION

Following sampling plans shall be applicable for PMI examination of various items.

- | | | | |
|----|--|---|--|
| A. | Flanges, Fittings
Valves, RTJ Gaskets | - | 100% by Supplier and 10% @ random witness by
EIL/TPIA |
| B. | Pipes | - | 100% (for pipes procured from traders)
2 random samples drawn from each
Size/Heat/Lot (for pipes procured directly from mills) |
| C. | Fasteners | - | |

Lot Size	Sample Size for EIL/TPIA	Sample size for Supplier
Upto 100	2% (Min 2)	Min 10%
101 to 500	1% (Min 3)	Min 10%
501 and above	0.5% (Min 5)	Min 10%

Note:

- a. For Welded Pipes and Fittings and flanges like Fig 8, Spacer and blinds etc. PMI shall be performed on Base Metal as well as weldments.

7.0 ACCEPTANCE CRITERIA

7.1 Base Metal

PMI test results showing presence of characteristic elements upto 10% less than the minimum specified value in the material specification and upto 10% more than the maximum specified value in the material specification shall be acceptable.

7.2 Deposited Weld Metal

For deposited weld metal using welding consumables matching with base metals, the recorded presence of characteristic elements upto 12.5% less than the minimum specified value in the

welding consumable specification and upto 12.5% more than the maximum specified value in the welding consumable specification shall be acceptable.

8.0 REJECTION CRITERIA

8.1 If PMI test results fall outside the acceptable range as specified in 7.0 above, the supplier shall obtain a quantitative check analysis performed by a laboratory acceptable to Owner / EIL / TPIA for a complete chemical analysis. Alternatively, the item can be tested with a spark analyser for verification. Results of this analysis shall be submitted to Owner / EIL / TPIA for final decision.

Decision of Owner / EIL / TPIA shall be final in this regard.

8.2 If any sample drawn to PMI test on the basis of percentage selection as per 6.0 above, fails to meet specification requirements, 100% of items of lot shall be tested for PMI by supplier. Any failure thereafter during sample check shall mean rejection of whole lot.

9.0 RECORDING AND DOCUMENTATION

The results of PMI examination shall be recorded in a Report Format as enclosed with this specification.

10.0 MARKING

10.1 All alloy materials tested by PMI shall be identified using either of the following methods by indicating "PMI OK"

- a) Bar Code/Hologram Sticker
- b) A low stress stamp marking

POSITIVE MATERIAL IDENTIFICATION REPORT BULK MATERIALS								Page	of
Project:		Client						Job No.	
PMI Report No.		Supplier/Sub-Supplier							
Purchase Order No.		Testing Agency							
Purchase Requisition No:		PMI Location							
Bulk Item Type (as per Requisition)									
Material Specification/Grade									
Number of items in Lot									
Requisition Item No./ Description		Major content, Weight Percent						Remarks Accept/Reject	
Element	Cr	Ni	Mo	V	Ti *	Cb/ Nb **	Mn ***		
Specified Range									
Actual observations									
1.									
2.									
3.									
4.									
5.									
6.									
7.									
8.									
Instrument Type / ID									
Last Service Date		Inspection Agency						Witnessed By	

* To be reported in case of SS321 Material

** To be reported in case of SS347 Material

*** To be reported in case of LTCS Material

बोलीकर्ता / आपूर्तिकर्ताओं / ठेकेदारों से गुणवत्ता प्रबंधन
प्रणाली अपेक्षाओं हेतु विनिर्देश

SPECIFICATION FOR QUALITY MANAGEMENT SYSTEM REQUIREMENTS FROM BIDDERS / SUPPLIERS / CONTRACTORS

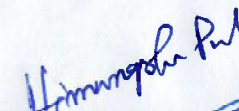
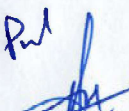
3	29-09-2025	General Revision	 QMS Standards Committee	 QMS Standards Committee	 AK	MN
2	12-06-2020	General Revision	QMS Standards Committee	QMS Standards Committee	SKB	SKS
1	12-03-2015	General Revision	QMS Standards Committee	QMS Standards Committee	MPJ	SC
0	04-06-2009	Issued as Standard Specification	QMS Standards Committee	QMS Standards Committee	SCT	ND
Rev. No.	Date	Purpose	Prepared by	Checked by	Standards Committee Convener	Standards Bureau Chairman
Approved by						

Abbreviations:

EIL	Engineers India Limited
ISO	International Organization for Standardization
MR	Material Requisition
PO	Purchase Order
PR	Purchase Requisition
QMS	Quality Management System

QMS Standards Committee

Convener: Mr. Anil Kumar

Members: Mr. Himangshu Pal (SCM-Inspection)
Mr. Ravindra Kumar (Const.)
Mr. Vinod Kumar (CQA)
Mr. Swapnil Vaishnav (Projects)
Mr. Vijay Kumar Garg (SCM)
Mr. Raju Kumar Pandey (Equipment Division)

CONTENTS

Clause	Title	Page No.
1.0	SCOPE.....	4
2.0	DEFINITIONS	4
3.0	REFERENCE DOCUMENTS	4
4.0	QUALITY MANAGEMENT SYSTEM – GENERAL	4
5.0	QUALITY SYSTEM REQUIREMENTS.....	4
6.0	AUDITS	6
7.0	DOCUMENTATION REQUIREMENTS	7

1.0 SCOPE

This specification establishes the Quality Management System requirements to be met by BIDDER for following purpose:

- QMS requirements to be met by suppliers/contractors after award of work/during contract execution.

2.0 DEFINITIONS

2.1 Bidder

For the purpose of this specification, the word “BIDDER” means the person(s), firm, company or organization who is under the process of being contracted by EIL / Owner for delivery of some products (including service). The word “Bidder” is considered synonymous to supplier, contractor or vendor.

2.2 Project Quality Plan (PQP)

Document tailored from Standard Quality Management System Manual of BIDDER, specifying how the quality requirements of the project will be met.

2.3 Owner

Owner means the owner of the project for which services / products are being purchased and includes their representatives, successors and assignees.

3.0 REFERENCE DOCUMENTS

- Specification for Documentation Requirements from Contractors (Doc. No. 6-78-0002)
- Specification for Documentation Requirements from Suppliers (Doc. No. 6-78-0003)

4.0 QUALITY MANAGEMENT SYSTEM – GENERAL

Unless otherwise agreed with EIL / Owner, the BIDDER proposed quality system shall fully satisfy all relevant requirements of ISO 9001 “Quality Management Systems – Requirements.” Evidence of compliance shall be current certificate of quality system registration to ISO 9001 or a recent compliance audit recommending registration from a certification agency. The quality system shall provide the planned and systematic control of all quality related activities for execution of contract. Implementation of the system shall be in accordance with BIDDER’S Quality Manual and PROJECT specific Quality Plan.

5.0 QUALITY SYSTEM REQUIREMENTS

5.1 BIDDER shall prepare and submit for review / record, Project Quality Plan / Quality Assurance Plan for contracted scope / job. The BIDDER’S Quality Plan shall address all of the applicable elements of ISO 9001, identify responsible parties within BIDDER’S organization, for the implementation / control of each area, reference the applicable procedures used to control / assure each area, and verify the documents produced for each area. The Project Quality Plan shall necessarily define control or make reference to the relevant procedures, for design and engineering, purchase, documentation, record control, bid evaluation, inspection, production/manufacturing, preservation, packaging and storage, quality control at construction site, pre-commissioning, commissioning and handing over (as applicable) in line with contract requirement and scope of work.

- 5.2 BIDDER shall identify all specified or implied statutory and regulatory requirements and communicate the same to all concerned in his organization and his sub contractor's organization for compliance.
- 5.3 BIDDER shall deploy competent and trained personnel for various activities for fulfilment of PO / contract. BIDDER shall arrange adequate infrastructure and work environment to ensure that the specification and quality of the deliverable are maintained.
- 5.4 BIDDER shall do the quality planning for all activities involved in delivery of order. The quality planning shall cover as minimum the following:
- Resources
 - Product / deliverable characteristics to be controlled.
 - Process characteristics to ensure the identified product characteristics are realized
 - Identification of any measurement requirements, acceptance criteria
 - Records to be generated
 - Need for any documented procedure
- The quality planning shall result into the quality assurance plan, inspection and test plans (ITPs) and job procedures for the project activities in the scope of bidder. These documents shall be submitted to EIL/Owner for review/approval, before commencement of work.
- 5.5 Requirements for sub-ordering of outsourced items /sub-contracting / purchasing of services specified in MR/ contract / tender shall be adhered to. In general all outsourced items will be from approved vendors of EIL. Wherever requirements are not specified, or approved sub vendors do not exist, the sub-contractor shall establish and maintain a system for purchasing / sub-contracting to ensure that purchased product / service conforms to specified requirements in concurrence with EIL / Owner. Criteria for selection of sub-contractor, evaluation, re-evaluation, maintenance of purchasing data and verification of purchased product (sub-contractor services), constitute important components of this requirement.
- 5.6 BIDDER shall plan and carry production and service provision under controlled conditions. Controlled conditions shall include, as applicable
- a) the availability of information that describes the characteristics of the product
 - b) the availability of work instructions
 - c) the use of suitable equipment
 - d) the availability and use of monitoring and measuring devices
 - e) the implementation of monitoring and measurement
 - f) the implementation of release, delivery and post-delivery activities
- 5.7 BIDDER shall validate any processes for production and service provision where resulting output cannot be verified by subsequent monitoring and measurement. This includes any process where deficiencies become apparent only after the product is in use or service has been delivered.
- 5.8 BIDDER shall establish a system for identification and traceability of product / deliverable throughout product realization. Product status with respect to inspection and testing requirements shall be identified.
- 5.9 BIDDER shall identify, verify, protect and safeguard EIL / Owner property (material / document) provided for use or incorporation into the product. If any Owner / EIL property is lost, damaged or otherwise found to be unsuitable for use, this shall be reported to the EIL / Owner.

BIDDER shall ensure the conformity of product / deliverable during internal processing and delivery to the intended destination. Requirements mentioned in the MR/ tender shall be adhered to.

- 5.10 BIDDER shall establish system to ensure that inspection and testing activities are carried out in line with requirements. Where necessary, measuring equipment shall be calibrated at specified frequency, against national or international measurement standards; where no such standard exists, the basis used for calibration shall be recorded. The measuring equipment shall be protected from damage during handling, maintenance and storage.
- 5.11 BIDDER shall ensure effective monitoring, using suitable methods, of the processes involved in production and other related processes for delivery of the scope of contract.
- 5.12 BIDDER shall monitor and measure the characteristics of the product/deliverable to verify that product requirement has been met. The inspection (stage as well as final) by BIDDER and EIL / Owner personnel shall be carried out strictly as per the approved ITPs or ITPs forming part of the contract. Product release or service delivery shall not proceed until the planned arrangements have been satisfactorily completed, unless otherwise approved by relevant authority and where applicable by Owner / EIL.
- 5.13 BIDDER shall establish and maintain a documented procedure to ensure that the product which does not conform to requirements is identified and controlled to prevent its unintended use or delivery
- 5.14 All non-conformities (NCs) / deficiencies found by the BIDDER'S inspection / surveillance staff shall be duly recorded, including their disposal action shall be recorded and resolved suitably. Effective corrective actions shall be implemented by the BIDDER so that similar NCs including deficiencies do not recur. The BIDDER shall take appropriate actions to address the Risks and Opportunities in the project.
- 5.15 All deficiencies noticed and reported by EIL / Owner shall be analysed by the BIDDER and appropriate corrective actions shall be implemented. BIDDER shall intimate EIL / Owner of all such corrective action implemented by him.
- 5.16 BIDDER should follow the standards, specifications and approved drawings. Concessions/Deviations shall be allowed only in case of unavoidable circumstances. In such situations Concession/deviation request must be made by the BIDDER through online system of EIL vendor portal for document exchange. URL of EIL vendor portal for document exchange is <http://edocx.eil.co.in/vportal>. BIDDER shall have documented procedure for control of documents.
- 5.17 All project records shall be carefully kept, maintained and protected for any damage or loss until the project completion, then handed over to EIL / Owner as per contract requirement (Refer Specification Nos. 6-78-0002 - Specification for Documentation Requirements from Contractors and 6-78-0003 - Specification for Documentation Requirements from Suppliers), or disposed as per relevant project procedure.

6.0 AUDITS

BIDDER shall plan and carry out the QMS audit for the job. Quality audit program shall cover design, procurement, construction management and commissioning as applicable including activities carried out by sub-vendors and sub-contractors. This shall be additional to the certification body surveillance audits carried out under BIDDER'S own ISO 9001 certification scheme.

The audit programs and audit reports shall be available with bidder for scrutiny by EIL / Owner. EIL or Owner's representative reserves the right to attend, as a witness, any audit conducted during the execution of the WORKS.

In addition to above, EIL, Owner and third party appointed by EIL/Owner may also perform Quality and Technical compliance audits. BIDDER shall provide assistance and access to their systems and sub-contractor / vendor systems as required for this purpose. Any deficiencies noted shall be immediately rectified by BIDDER.

7.0 DOCUMENTATION REQUIREMENTS

BIDDER shall submit following QMS documents immediately after award of work (Within one week) for record / review by EIL / Owner/ TPIA(Third Party Inspection Agency), as applicable:

- Organization chart (for complete organization structure and for the project)
- Project Quality Plan/Quality Assurance Plan
- Job specific Inspection Test Plans, if not attached with PR
- Job Procedures
- Inspection/Test Formats

In addition to above QMS documents, following documentation shall be maintained by the BIDDER for submission to EIL / Owner on demand at any point of time during execution of the project:

- Quality Manual
- Certificate of approval for compliance to ISO9001 standard
- Procedure for Control of Non-conforming Product
- Procedure for Control of Documents
- Sample audit report of the QMS internal and external audits conducted during last one year
- Customer satisfaction reports from at least 2 customers
- Project QMS audit report
- Technical audit reports for the project
- Corrective action report on the audits

Documents as specified above are minimum requirements. BIDDER shall submit any other document/data required for completion of the job as per EIL/Owner instructions.

आपूर्तिकर्ताओं से प्रलेखन
अपेक्षाओं हेतु विनिर्देश

SPECIFICATION FOR DOCUMENTATION REQUIREMENTS FROM SUPPLIERS

3	29-09-2025	General Revision	QMS Standards Committee	QMS Standards Committee	AK	MN
2	01-06-2020	General Revision	QMS Standards Committee	QMS Standards Committee	SKB	SKS
1	12-03-2015	General Revision	QMS Standards Committee	QMS Standards Committee	MPJ	SC
0	04-06-2009	Issued as Standard Specification	QMS Standards Committee	QMS Standards Committee	SCT	ND
Rev. No.	Date	Purpose	Prepared by	Checked by	Standards Committee Convener	Standards Bureau Chairman
Approved by						

Abbreviations:

DCI	Document Control Index
EIL	Engineers India Limited
EPS	Electronic Procurement System
FOA	Fax of Acceptance
IC	Inspection Certificate
IRN	Inspection Release Note
ITP	Inspection and Test Plan
LOA	Letter of Acceptance
LR	Lorry Receipt
MR	Material Requisition
ODC	Over Dimension Consignment
PO	Purchase Order
PR	Purchase Requisition
PVC	Polyvinyl Chloride
QAP	Quality Assurance Plan
QMS	Quality Management System
RPO	Regional Procurement Office
TPIA	Third Party Inspection Agency
URL	Universal Resource Locator
V-Portal	Vendor Portal

QMS Standards Committee

Convener: Mr. Anil Kumar

Members: Mr. Himangshu Pal (SCM-Inspection)
Mr. Ravindra Kumar (Const.)
Mr. Vinod Kumar (CQA)
Mr. Swapnil Vaishnav (Projects)
Mr. Vijay Kumar Garg (SCM)
Mr. Raju Kumar Pandey (Equipment Division)

CONTENTS

Clause	Title	Page No.
1.0	SCOPE.....	4
2.0	DEFINITIONS.....	4
3.0	REFERENCE DOCUMENTS.....	4
4.0	DOCUMENTATION REQUIREMENTS.....	4

Annexures:

S. No.	Title	Doc. No.
1.	Format for completeness of Final Documentation	Format No. 3-78-0004

4.2.4 Documents as specified in PO/PR/MR are minimum requirements. Supplier shall submit any other document/data required for completion of the job as per EIL/Owner instructions.

4.3 Style and Formatting

4.3.1 All Documents shall be in ENGLISH language and in M.K.S(Meter-Kilogram-Second) System of units.

4.3.2 Before forwarding the drawings and documents, contractor shall obtain the title block from EIL and ensure that the following information are properly mentioned in each drawing:

- Purchase Requisition Number
- Name of Equipment / Package
- Equipment / Package Tag No.
- Name of Project
- Client
- Drawing / Document Title
- Drawing / Document No.
- Drawing / Document Revision No. and Date

4.4 Review and Approval of Documents by Supplier

4.4.1 All, the Drawing/Documents shall be reviewed, checked, approved and duly signed/stamped by supplier before submission. Revision number shall be changed during submission of the revised supplier documents and all revisions shall be highlighted by clouds. Whenever the supplier requires any sub-supplier drawings to be reviewed by EIL, the same shall be submitted by the supplier duly reviewed, approved and stamped by the supplier. Direct submission of sub-supplier's drawings without contractor's / suppliers' approval shall not be entertained.

4.5 Document Category

Following review codes shall be used for review of supplier Drawings/Documents:

- | | | |
|---------------|---|---|
| Code 1 | - | No comments. Proceed with Manufacture / Fabrication / Construction as per the document. |
| Code 2 | - | Proceed with Manufacture / Fabrication / Construction as per commented document. Revised document required. |
| Code 3 | - | Document does not conform to basic requirements as marked. Resubmit for review. |
| Code R | - | Document is retained for Records. Proceed with Manufacturing / fabrication as per Tender/ Contract Requirement. |
| Code V | - | Void, Document is returned as invalid. |

Document is marked as Void under following conditions:

- a) Wrong item drawing uploaded.
- b) Superseded or obsolete submission.
- c) Duplicate submission.
- d) Out of sequence submission.
- e) Mismatch in document name and title under which document uploaded.
- f) Document not legible.
- g) For PMC projects, document not signed and stamped by contractor and DEC

4.6 Methodology for Submission of Documents to EIL/Owner

4.6.1 Document Control Index (DCI)

Supplier shall create and submit Document Control Index (DCI) for review based on PO/PR/MR along with schedule date of submission of each drawing/document on EIL Vendor Portal. The DCI shall be specific with regard to drawing/document no. and the exact title. Proper sequencing of the drawings/documents should be ensured in schedule date of submission.

4.6.2 Submission of Drawings/Documents / Data

Drawings/documents, data and DCI shall be uploaded on the EIL Vendor Portal as per approved DCI. The detailed guidelines for uploading documents on EIL Vendor Portal are available on URL: <http://edocx.eil.co.in/vportal>

4.6.3 Statutory Approvals

Wherever approval by any statutory body is required to be taken by Supplier, the Supplier shall submit copy of approval by the authority to EIL.

4.6.4 Manufacturing Schedule

Supplier shall prepare milestone based (milestones such as document submission, sub ordering, manufacturing, Inspection, dispatches, etc.) manufacturing schedule for the order, to meet delivery as per FOA/PO terms. Supplier shall submit manufacturing schedule to concerned Regional Procurement Office (RPO) of EIL, with a copy to Head office monitoring team/Owner for review within 7 days from date of FOA/PO. Same shall be uploaded in the EPS portal of EIL i.e., <https://www6.eil.co.in/epsinspection/supp>

4.6.5 Schedule and Progress Reporting

Supplier shall submit Monthly Progress Report (MPR) on or before the 9th of every month indicating following milestone-based progress details as minimum:

- Drawing submission and approval status and schedule for submission of revised drawing / fresh Drawing requiring approval as per approved DCI
- Sub-ordering plan/details for all major items indicating item description, sub-order number, Date of sub-ordering, sub-vendor name, Location, contractual delivery data and expected delivery dates at main vendor's shop and other critical details requiring timely receipt of sub-ordered items at shop.
- Shop manufacturing progress indicating major milestone progress, in case of missing any milestone date, catch up plan for the same and expected dispatch date from shop and expected delivery date at site.
- Area requiring special attention/concern and proposed action plan to resolve the same.

First Monthly Progress Report (MPR) shall be submitted within 2 weeks from FOA/LOA. In case of exigencies, EIL/Owner can ask for report submission as required on weekly/fortnightly/ad-hoc basis depending upon supply status and supplier shall furnish such reports promptly without any price implication. Format for progress report shall be submitted by the Supplier during kick off meeting or within 2 weeks of receiving FOA/LOA, whichever is earlier.

4.7 Inspection and Testing

4.7.1 Quality Assurance Plan/Inspection and Test Plan

If Inspection and test plans (ITP) are attached with MR/PR same shall be followed along with additional tests requirement (if any) mentioned in MR/ PR. However for cases wherein EIL Standard ITPs not available/ have not been attached with MR/PR, Supplier shall submit within one week of receiving FOA/LOA, the Quality Assurance Plan for inspection & testing at various stages of production, quality control records for critical bought out items/ materials and site assembly & testing as may be applicable to the specific order and obtain approval from concerned Regional procurement Office of EIL/third party inspection agency, as applicable.

For Package equipment contracts, the supplier shall prepare a list of items/ equipment and their inspection categorization plan for all items included in the scope of supply immediately after receipt of order and obtains approval for the same from EIL. The items shall be categorized into different categories depending upon their criticality for the scope of inspection of TPIA and/or EIL.

4.7.2 Inspection Requirements:

Supplier shall perform internal inspection as per ITP/ approved QAP at their works based on approved documents/drawings. Upon satisfactory internal inspection, supplier shall raise inspection call through Inspection call Module of EPS (<https://www6.eil.co.in/epsinspection>) to concerned Regional Procurement Office (RPO) of EIL/ TPIA/ Owner with advance notice as per contract along with Internal test reports. Where inspection is not in the scope of EIL and is carried out by nominated Third Party Inspection agency (TPIA), Inspection Release Note (IRN) issued by the nominated TPIA along with Manufacturer's Test Certificate (MTC) shall be uploaded in EIL EPS Portal (<https://www6.eil.co.in/epsinspection>).

All changes w.r.t. PR shall be recorded through agreed variations or Concessions & Deviations. Conflict, if any, between PR / Job specifications and approved drawings, shall be brought to the notice of EIL / owner by the supplier/ contractor. Decision of EIL / owner will be binding on the supplier and to be complied without time and cost implications.

Identified bought out items/ raw material shall be procured under TPIA as per ITP.

4.7.3 Inspection Release Note (IRN)/ Inspection Certificate (IC)

IRN/ IC shall be issued by EIL Inspector/ third party inspection agency on successful inspection, review of test reports/ certificates as per specifications & ITP/ agreed quality plan (as applicable) and only after all the drawings/documents as per DCI are submitted and are accepted under review code-I or code R. Supplier shall ensure that necessary documents/manufacturing and test certificates are made available to EIL/TPIA as and when desired.

Note 1: Non fulfilling above requirement shall result into appropriate penalty or with- holding of payment as per conditions of PO/PR/MR.

Note 2: For items where IRN/IC is issued by TPIA, supplier to ensure that following as a minimum must be mentioned by TPIA in IRN/IC:

- a) PR document number
- b) List of drawings/documents with EIL approval code
- c) Tests witnessed, documents reviewed

- d) Compliance statement by TPIA that product meets the requirement as specified in EIL PR, standard specifications, Inspection Test Plan/QAP and approved documents.

4.8 Transportation Plan

Transportation Plan for Over Dimensional Consignments (ODC), if any, shall be submitted within 2 weeks of receiving FOA/LOA, for approval. Unless otherwise specified, consignments with parameters greater than following shall be considered as over dimensional.

Dimensions : 4 meters width x 4 meters height x 20 meters length

Weight : 32 MT (Metric Ton)

Dimensions and weight provided above are inclusive of all nozzles, attachments, transportation saddles etc.

Physical Rout survey for ODC movement shall be submitted to EIL within 8 weeks of receiving FOA / LOA.

4.9 Dispatch Details

Upon receipt of IRN/IC from EIL inspector/TPIA, supplier shall dispatch items within 2 days. Item wise dispatch details shall be uploaded in EIL's EPS module within 24 hours of any item dispatched from shop, indicating PR item no, Quantity dispatched, Transporter's name, LR Number/ LR date.

- 4.10 Vendor shall ensure timely uploading of Manufacturing Schedule, Monthly Progress Report, Inspection Certificate (IRN) issued by the TPIA (as applicable for PO where Inspection is under nominated Third Party Inspection Agency) and updation of item wise dispatch details in EPS portal of EIL (<https://www6.eil.co.in/epsinspection>).

4.11 Final Documentation

- 4.11.1 Supplier shall prepare final documents in line with VDR (Vendor Document Requirements) attached with PR/Tender. A copy of final document along with filled in Format for Completeness of Final Documentation (Format No. 3-78-0004) to be submitted to EIL Inspector/TPIA for review & approval within 2 weeks from dispatch. Upon receipt of EIL/TPIA endorsement on Completeness of Final Documents, supplier shall submit soft/hard copies of Final documents to EIL/Owner in requisite quantity as per PO/PR details, along with covering letter. A copy of covering letter to be submitted to the concerned Regional Procurement Office (RPO) of EIL/Owner.

4.11.2 As Built Drawings

Minor Shop changes made by Supplier after approval of drawings under 'Code 1' by EIL and deviations granted through online system, if any, shall be marked in hard copies of drawings which shall then be stamped 'As-built' by the supplier. These 'As-built' drawings shall be reviewed and stamped by EIL Inspector/TPIA. Supplier shall prepare scanned images files of all marked – up 'As – built' drawings. Simultaneously Supplier shall incorporate the shop changes in the native soft files of the drawings also.

4.11.3 Packing/Presentation of Final Documents

Final Documents shall be legible photocopies in A4, A3 size only. Drawings will be inserted in plastic pockets (both sides transparent, sheet thickness minimum 0.1 mm) with an extra strip of 12 mm wide for punching so that drawings are well placed.

Final Documentation shall be bound in Hard board Plastic folder(s) of size 265 mm x 315 mm (10½-inch x 12½-inch) and shall not be more than 75 mm thick. It may be of several volumes and each volume shall have a volume number, index of volumes and index of contents of that particular volume. Where number of volumes are more, 90mm thickness can be used. Each volume shall have top PVC sheet of minimum 0.15 mm thick duly fixed and pressed on folder cover and will have 2 lever clips. In case of imported items documents, 4 lever clip shall also be accepted. All four corners of folders shall be properly metal clamped. Indexing of contents with page numbering must be incorporated by supplier. Spiral/Spico bound documents shall not be acceptable. As mentioned above, books should be in hard board plastic folders with sheets punched and having 2/4 lever clips arrangement.

Each volume shall contain on cover a Title Block indicating package Equipment Tag No. & Name, PO/Purchase Requisition No., Name of Project and Name of Customer. Each volume will have hard front cover and a reinforced spine to fit thickness of book. These spines will also have the title printed on them. Title shall include also volume number (say 11 of 15) etc.

4.11.4 Submission of Soft Copies

Supplier shall submit to EIL, the scanned images files as well as the native files of drawings/documents, along with proper index.

In addition to hard copies, Supplier shall submit soft copies of all the final drawings and documents in pen drive or any other specified medium with proper identification tag, all text documents prepared on computer, scanned images of all important documents (not available as soft files), all relevant catalogues, manuals available as soft files (editable copies of drawings/text documents, while for catalogues/manuals/proprietary information and data, PDF files can be furnished). All soft files shall be appropriately named, systematically indexed, and duly bookmarked in PDF format to facilitate ease of reference and access.

All the above documents shall also be uploaded on the EIL Vendor Portal and if applicable on Client Server also.

4.11.5 Completeness of Final Documentation

Supplier shall get the completeness of final documentation verified by EIL/TPIA, as applicable, and attach the Format for Completeness of Final Documentation (Format No. 3-78-0004) duly signed by EIL Inspector or TPIA as applicable to the final document folder.

COMPLETENESS OF FINAL DOCUMENTATION

Name of Supplier/Contractor :
 Customer :
 Project :
 EIL's Job No. :
 Purchase Order No./
 Contract No. :

 Purchase Requisition No./
 Tender No. : Rev. No.:

 Name of the Work/ Equipment :
 Tag. No. :
 Supplier's/ Contractor's Works :
 Order No.

Certified that the Engineering Documents/ Manufacturing & Test Certificates submitted by the supplier (as per Index sheet mentioned in Annexure-1) are complete in accordance with the Vendor Data Requirements of Purchase Requisition / Tender.

Signature	:	Signature	:
Date	:	Date	:
Name	:	Name	:
Designation	:	Designation	:
Department	:	Department	:

Supplier/Contractor

EIL/TPIA

