

**CENTRE FOR DEVELOPMENT OF TELEMATICS**  
**Electronics City-Phase I, Hosur Road**  
**Bangalore - 560 100**



**“SUPPLY, INSTALLATION, TESTING AND COMMISSIONING OF EARTHING FOR ELECTRICAL INSTALLATIONS  
AT C-DOT CAMPUS”**

**NIT NO: C-DOTB/TENDER/2026-2027/001 Dated 29.04.2026**

**TENDER DOCUMENT**

**2026-27**

**CENTRE FOR DEVELOPMENT OF TELEMATICS**

Electronics City-Phase I, Hosur Road  
Bangalore – 560 100

**INDEX**

<b>SL No</b>	<b>CONTENTS</b>	<b>PAGE NO</b>
1	Notice Inviting Tender	3
2	Eligibility Criteria, Evaluation of Bids	4-5
3	General terms and conditions	5-7
5	Special terms and conditions	7-9
6	Other terms and conditions	9
7	Scope of works and Technical Specification	10-12
8	Bill of Quantities	13
9	Annexure – I	14
10	Annexure – II	15

**CENTRE FOR DEVELOPMENT OF TELEMATICS**

Electronics City-Phase I, Hosur Road  
Bangalore – 560 100

**NOTICE INVITING TENDER**

**Tender Notice Number: C-DOTB/TENDER/2026-2027/001 dated 29.04.2026**

**The Centre for Development of Telematics invites Tenders for Supply, Installation, Testing and Commissioning of Earthing for Electrical Installations at C-DOT Campus from Eligible bidders.**

<b>SI No</b>	<b>Description</b>	<b>Details</b>
1	Name of Work	<b>Supply, Installation, Testing and Commissioning of Earthing for Electrical Installations.</b>
2	Time of Completion	<b>60 Days</b>
4	Last date and time for receipt of tenders	<b>18.05.2026 - 09.00 Hrs only</b>

**Important Note: All the bidders are requested to attend the Pre-bid meeting to be held on 07.05.2026 at 11 Am at the office of Centre for Development of Telematics, Bengaluru – 560100**

## **Eligibility Criteria:**

The bidder should meet the following Eligibility Criteria and must submit documentary evidence in support of their claim for fulfilling the criteria and they should submit an undertaking on their official letterheads to the fairness of these documents while submitting the bid. The bids received without the documentary evidence will be rejected outright.

1. The prospective bidder shall either be a company incorporated under the Companies Act, 1956/2013 or a LLP under the LLP Act, 2008 or a Partnership Firm under the Partnership ACT, 1932 Or A Proprietorship firm.
2. The Bidder should have an average annual turnover of Rs.3.0 Lakhs per annum in the last three years in similar kind of business. The Bidder, should submit the turnover per annum for the last three audited years (FY. 2023-24, 2024-25 and 2025-26) in similar kind of business with documentary evidence.
3. Copies of the work order and completion certificate successfully executed for similar kind work during the last 7 years for reputed Public Ltd. Companies, Public sector, Govt. Institutions and autonomous bodies in the following manner
4. A) Bidder should have successfully completed one single assignment of similar kind for Rs.3,28,000/-  
OR  
B) Two similar works of Rs 2,05,000/- each OR  
C) Three Similar works of Rs 1,64,000/-each

Eligible similar work shall mean works of "**Internal/External Electrical wiring or Electrical Installation work but INCLUDING earthing work essentially.**"

5. The Company / Firm / Individual, any Partners of the firm should not be black listed by any PSU or Government departments/ UN or its agencies/ institutions/ private organizations in respect of any assignments or behavior of any Partner/ employee. The firm / Individual will provide an undertaking that such Partner/ employee will not be involved in the said contract, directly or indirectly.
6. An undertaking should be submitted that there are no legal suits / criminal cases pending against the Firm and its Proprietor/Partners or having not been earlier convicted on grounds of moral turpitude or for violation of laws in force.
7. Should have valid electrical contractor license from State Govt. or Govt. of India.

### **EVALUATION OF BIDS:**

- The Technical Evaluation Committee will technically qualify the bids based on detail scrutiny of all documents furnished by the tenderers and eligibility criteria stipulated in the tender document. In this stage the committee may inspect selected works carried out by tenderer
- The price bid of only those tenderers who have been qualified during the scrutiny and technical evaluation will be opened separately on a specified date (with due intimation to the qualified tenderers) and further processed, as per tender procedure/stipulations.

### **GENERAL TERMS AND CONDITIONS OF THE BID:**

1. The tender shall be divided into two parts:

I. The first part shall be “Technical” Bid, which includes the following details:

- a) Detailed literature including Data Sheets of quoted products
- b) Supporting Documents as per the Eligibility Criteria.

**Note:**

The first part (Technical Bid) shall not contain any financial aspects of the offer. If financial aspects are found into this part, their tender shall be substantially rejected.

II. The Second part (Financial Bid) should contain detailed financial outlay with List of deliverables / Bill of materials / Bill of Quantities and services, unit price of items as in the technical bid (i.e., First Part).

2. The Tenderer should ensure that all the pages of tender/bid submitted are duly signed by the Authorized Signatory before submission of Bid.
3. The tenders should be complete in all respects and the details specified in this request should be adhered to before submission. Otherwise, tenders are liable to be rejected.
4. Tender should be valid for 180 days from the date of opening of technical bid.
5. The Unit price should be mentioned legibly and clearly. Taxes and other levies should be indicated separately. The rates quoted by the bidder will be deemed to be inclusive of taxes applicable, if it is not explicitly mentioned in the tender.
6. C-DOT will have the right to issue the addendum to tender documents to clarify, amend, modify, supplement or delete any of the conditions, clauses or items/specifications stated therein, each addendum so issued shall form part of original invitation to tender and will be duly notified in the website
7. **Work executed as sub-contract or joint-venture will not be considered for**

**eligibility/evaluation.**

8. C-DOT reserves the right to reject any or all of the tenders received without assigning any reason. It also reserves the right to accept an offer other than the lowest.
9. C-DOT reserves the right to postpone/extend the due date for submission/opening date of the tender without assigning any reason
10. Successful Design, Supply, Installation, Testing and Commissioning should be made at the site as per the tender document at CENTRE FOR DEVELOPMENT OF TELEMATICS, Electronic City, Bengaluru – 560 100, at suppliers cost and risk. The design shall be got approved before supply and Installation.
11. Any Technical clarification required towards submission of offer may please be mailed to [tender@cdot.in](mailto:tender@cdot.in)
12. Canvassing in connection with tender will result in disqualification.
13. Even though the tenderers meet the qualifying criteria, they are subject to be disqualified if they have made misleading or false representations in the forms, statements and attachments submitted in proof of the qualification requirements.
14. A self-declaration towards not having record of poor performance such as abandoning the works/ not properly completing the contract, inordinate delays in completion, litigation history, or financial failures etc., has to be provided.
15. The Tenderer along with his team, at the Tenderer's own cost, responsibility and risk may visit and examine the Site of Works and its surroundings and obtain all information that may be necessary for preparing the Bid and entering into a contract. Nature of the site, means of access to the site and in general shall themselves obtain all the necessary information as to risks, contingencies and other circumstances which may influence or affect their tender. The tenderer shall be deemed to have full knowledge of the site whether he inspects or not and no extra charges consequent on any misunderstanding or otherwise shall be allowed. (Timings 2.00 pm to 5.00 pm – Monday to Friday) For any clarification, tenderer may discuss with the Engineer-in-Charge.
16. The tenderer has to comply with the labour laws while executing the work.
17. The tenderer will be responsible for the insurance, safety and health of all the workers during the execution of work.
18. C-DOT will have no liability to the tenderer, if he/she incurs loss on account of stoppage of work or delay due to violation with respect to safety & quality procedure.
19. For specialized items the work shall be carried out completely as per the manufacturer's

specifications and recommendations/CPWD specifications/IS specifications, if the item specifications are incomplete.

20. The work to be carried out under the Contract shall, except as otherwise provided in these conditions, include all labour, materials, tools, plants, equipment and transport which may be required in preparation of and for the full and entire execution and completion of the works. The descriptions given in the Schedule of Quantities shall, unless otherwise stated, be held to include wastage on materials, carriage and cartage, carrying and return of empties, hoisting, setting, fitting and fixing in position and all other labours necessary in and for the full and entire execution and completion of the work as aforesaid in accordance with good practice and recognized principles.
21. The support contact details and escalation matrix has to be provided.
22. In addition to the above mentioned all terms & conditions the tenderer shall execute the work as per the latest CPWD General Conditions of Contract (GCC) and IS standards.

**SPECIAL TERMS AND CONDITION:**

1. Contractor should depute a qualified supervisor dedicated for this site, who will coordinate work execution activities and interact with the C-DOT representative responsible for supervision of work. Without a Supervisor, work will not be allowed. All the persons deployed at C-DOT site should carry valid gate-passes. Any negligence/offence on their part will attract immediate removal from site.

2. Price escalation clause is not applicable.

**3. Safety codes and labour regulations**

In respect of all labour employed directly or indirectly on the work for the performance of the contractor's part of work, the contractor at his own expense, will arrange for the safety provisions as per the statutory provisions, B.I.S recommendations, factory Act, workman's compensation Act, CPWD code and instructions issued from time to time.

The contractor shall provide necessary barriers, warning signals and other safety measures while executing the works or wherever necessary so as to avoid accident. C-DOT will not be responsible for any accident occurred or damage incurred or claims arising there from during the execution of work.

**4. Machinery for Installation:**

All tools and tackles required for unloading / handling of equipment's and materials at site, their assembly, installation, testing and commissioning shall be the responsibility of the contractor.

## 5. Care of the Campus & Building:

The tenderer shall ensure the work area of the campus is kept clean and the movements are controlled so as to avoid disturbance to work area/Campus. The waste shall be handled in environmentally friendly way. Any damage to the existing service lines during execution of the work shall be got rectified by the tenderer at his own cost & risk.

6. **Payment terms:** 100% payment after satisfactory completion of the work and submission of the final bill
7. **Completion Time:** Time limit for completion of the work is 60 days from the date of the order issued. The time shall be the essence of this contract and entire work as titled above is to be completed in all respects within the given time from the date of issue of work order. The successful bidder has to submit the time & activity chart for the completion of work.
8. **Site condition:** Before quoting, the contractor must visit the site to inspect the work and shall fully acquaint himself about the conditions and scope of work with regard to accessibility of site required for the satisfactory execution of work. No compensation on account of any site difficulties will be entertained, at a later date, after award of the works.
9. **Guarantee/Defect Liability Period:** The contractor should guarantee for the works / items executed / supplied by him against the manufacturing / engineering defect and bad material / workmanship for a period of one year from the date of acceptance by C-DOT. During this period if any replacement of items and/or repairs / rectification is needed, the same should be replaced / repaired free of cost to C-DOT.
10. **Liquidated Damage:** In case the work is delayed beyond the specified completion period for reasons attributed to the contractor, deductions on account of Liquidated damages @ 0.5 % of the contract value per week will be deducted subject to a maximum of 10% of the total cost excluding GST. However, in case the works are delayed beyond 20 weeks is to be treated as an exception and C-DOT will reserve the right to impose additional penalty at its discretion.
11. **Specifications:** Contractor is to follow relevant Indian standards codes for fire, electricity, safety and building rules. Where not specified will be as per the best industry practices, ISI marked or CPWD Technical Specifications whichever is superior. In case of any variation in specifications at different places in NIT, the best /richer specification will be considered. However, decision of C-DOT will be final.
12. Inferior and Poor quality material shall not be accepted
13. The Contractor shall clean the site after completion of work. Any dismantled material shall be stacked in designated place as instructed by the Engineer-in-charge.
14. Measurement shall be taken jointly by the Engineer-in-Charge or his authorized representative and by the contractor or his authorized representative.
15. All materials brought at site shall be got approved from the Engineer in charge.
16. Contractor shall carry out the various tests as enumerated in CPWD/BIS specification at

his own cost.

## **OTHER TERMS AND CONDITIONS:**

### **1. GENERAL STANDARD**

These standards are intended to describe a quality Earthing work using all new equipment, parts, materials, components installation, and service techniques. This is a lump sum contract. Any item which is essential for the completion of the job but inadvertently not mentioned in the Schedule of Quantities shall have to be executed by the Bidder within the quoted rate and nothing extra would be paid.

### **2. DRAWINGS, IF ANY**

Before commencing the work, the bidder shall prepare and submit all drawings in required number necessary to show the general arrangement and details of earthing work. Manufacturer's drawings, catalogues, pamphlets and other documents submitted for approval.

### **3. PAINTING**

All exposed metal work furnished under these specifications, unless otherwise specified, shall be shop and properly painted. Shop coats of paint that have become marred during shipment or erection, shall be cleaned off with mineral spirits, wire brushed and spot painted over the affected areas, then coated with enamel paint to match the finish over the adjoining shop painted surface.

## **SCOPE OF WORK AND TECHNICAL SPECIFICATIONS**

### **1.0. SITE INFORMATION:**

It is understood that before quoting the rates, the bidder has visited the worksites

at his own cost and has acquainted himself fully with the nature and quantum of job to be carried out by him in case of Award. Ignorance of this will not be considered after the award of Contract. The contractor will be responsible to complete the entire job in all respects, including any other work necessary to complete the job satisfactorily, though specifically not covered in the "Scope of Work & Technical Specifications"

## 2.0. DETAILS OF THE WORK:

The complete details of the work is as detailed below.

- (i) The scope of work would be in general and not limited to the following, to execute the work as per the terms and conditions of the contract during installation of new earth pits, supply and laying of earth strip & earth pit covers in various locations of the Campus.
- (ii) The brief scope of work shall be carrying out necessary excavation, Providing and fixing of earth electrode with Copper Plate, GI Plate, GI pipe and funnel, providing and filling of charcoal and salt, construction of earth pit chambers, Providing earth pit cover, Painting of earth pit covers, measurement of earth pit resistance and connection the earth pit to earth grid / existing earth pit/electrical machines as required by the C-DOT Engineer in charge.
- (iii) The details of installations along with the quantity of new earth pits to be installed will be mentioned in Bill of Quantity.

## 3.0. EXCAVATION OF EARTH PITS:

- (i) The job includes excavation of hard / soft soil of 3 meters (Depth) and based on the type of earthing (Plate / Pipe earthing). Excavation shall be carried out by means of digging the soil where ever is practicable or by means of auguring the soil.
- (ii) Excavation and Dismantling of Earth Pits: The dismantling of existing electrodes shall be carried out as required. Excavation shall be performed either by manual digging wherever practicable or by auguring, as directed by the C-DOT Engineer-in-Charge.
- (iii) The necessary tools and tackles, material and labour required for carry out digging or auguring of earth pits is in the scope of the contractor. No additional payment will be made for the same.

## 4.0. PROVIDING AND FIXING OF EARTH ELECTRODE:

- (i) **Pipe Earthing:** The job includes providing of 40 mm diameter NB class GI pipe of not less than 3.25 mm thickness, 3.61 Kg/meter weight and 4 meters length. 12 mm diameter holes are to be drilled on the earth electrode at 150 mm intervals for a length of 2.5 meters from bottom portion of the GI electrode for watering purpose. Bottom portion of the GI earth electrode is to be made sharp for easy penetration into the soil.

- (ii) **Plate Earthing (G.I / Cu.):** Copper earthing plate shall be 600 mm X 600 mm X 3 mm thick including accessories and watering pipe of 2.7 Meter long 20 mm dia. G.I. pipe (medium class) etc.  
G.I earthing plate shall be 600 mm X 600 mm X 6 mm thick including accessories and watering pipe of 2.7 Meter long 20 mm dia. G.I. pipe (medium class) etc.
- (iii) Funnel with a mesh shall be provided on the top portion of the earth electrode for watering purpose.
- (iv) GI earthing plate welded to the earth electrode at the top shall have hot dip galvanized coating of not less than 10 microns thickness.
- (v) Typical drawings of earth pit are enclosed as Annexure-I & II.
- (vi) The necessary tools and tackles, material and labour required for carrying out welding of GI earth plate, drilling of holes on earth electrode and GI earth plate / Cu. Earth plate etc is in the scope of the contractor. No additional payment will be made for the same.

#### 5.0. PROVIDING AND FILLING OF CHARCOAL AND SALT:

- (i) The job includes filling up of the earth pit with high conductivity soil and alternate layers of charcoal or coke dust and common salt after placing the earth electrode in the excavated earth pit. Charcoal, common salt and high conductivity soil are watered and rammed as tight as possible shall be carried out for proper bonding of the electrode with the adjacent soil.
- (ii) The necessary tools and tackles, material and labour required for carry out filling of Charcoal, common salt and high conductivity soil, watering and ramming etc is in the scope of the contractor. No additional payment will be made for the same.

#### 6.0. Earthing System Inspection Chamber:-

- (i) The job includes providing earth pit brick chambers of 450 mm x 450 mm size. Depth of the earth pit chamber should be 400 mm from the ground level. Earth pit chamber and cover should be finished at 100 mm above ground level. Inside portion of the pit shall be plastered & cleaned properly.

#### 7.0. PROVIDING EARTH PIT COVERS:

- (i) The job includes providing FRP (Fiber Reinforced Plastic) or Mild steel / cast iron plate not less than 8 mm thick, on the top portion of the earth pit chamber with suitable handle for lifting arrangement. A base frame of suitable dimensions shall be fixed to the top portion of the earth pit chamber to accommodate earth pit cover.

## 8.0. Identification of Earth Pits:

- (i) Earth pit details duly painted & marked with of earth pit number, individual pit resistance and location name on the display board shall be provided by the contactor for each individual earth pit.

## 9.0. MEASUREMENT OF EARTH PIT RESISTANCE:

- (i) The job includes measurements of resistance of the new earth pits when connected to grid as well as individually.
- (ii) The values are tabulated and submitted to concerned C-DOT Engineer In charge. If the individual earth pit resistance is not within the limits (Grid resistance less than 1 ohm and individual pit resistance less than 2 ohms) then the vendor shall make it functional at no extra cost.

## 10.0. SUPPLY & LAYING OF EARTH STRIP:

Supply & Laying of 50 x 6 mm Cu/GI earth strip and 25 x 5 mm GI earth strip in various terminals / installations of C-DOT.

- (i) The new earth pit is to be connected with the adjacent earth pit / main earth grid/ electrical machines as required by the C-DOT Engineer in charge.
- (ii) All hardware, including spring washers used for this purpose shall be hot dip galvanized as per IS: 802, or zinc passivated.
- (iii) Joints and tapings in the main earth loop shall be made in such a way that reliable and good electrical connections are permanently ensured. All joints below ground and above ground shall be welded and suitably protected by applying bitumen.
- (iv) Connecting the new earth pit to earth grid including all consumables like Brass/SS bolts & nuts, washers on both sides etc., is also in the scope of the contractor.
- (v) The existing earth strip old/damaged is to be connected with the adjacent earth pit / main earth grid with 25 mm x 5 mm GI earth strip to form the earth grid.

**Note : (1)** The work shall be carried out strictly as per the IS – 3043 and CPWD General Specification for Electrical Works Part-I Internal -2023 amended up to dates, relevant electricity act BIS/IEC and as per direction of Engineer –in - Charge.

(2) The contractor should guarantee for the works / items executed by him against the material / workmanship for a period of one year from the date of acceptance by C-DOT.

## BILL OF QUANTITIES

**Supply, Installation, Testing and Commissioning of Earthing for Electrical Installations  
at C-DOT Campus**

Sl.No	Description	Qty	Unit	Unit Rate	Total Amount
1	Earthing with copper earth plate 600 mm X 600 mm X 3 mm thick including accessories, and providing masonry enclosure with cover plate having locking arrangement and watering pipe of 2.7 Meter long etc. with charcoal/ coke and salt as required.	4	set		
2	Earthing with G.I. earth plate 600 mm X 600 mm X 6 mm thick including accessories, and providing masonry enclosure with cover plate having locking arrangement and watering pipe of 2.7 Meter long etc. with charcoal/ coke and salt as required.	4	set		
3	Earthing with G.I. earth pipe 4.0 Meter long, 40 mm dia including accessories, and providing masonry enclosure with cover plate having locking arrangement and watering pipe etc. with charcoal/ coke and salt as required.	21	set		
4	Supplying and laying 50 mm X 5 mm copper strip at 0.50 meter below ground as strip earth electrode, including connection/ terminating with nut, bolt, spring, washer etc. as required. (Jointing shall be done by overlapping and with 2 sets of brass nut bolt & spring washer spaced at 50mm)	30	Mtr		
5	Supplying and laying 25 mm X 5 mm G.I strip at 0.50 meter below ground as strip earth electrode, including connection/ terminating with G.I. nut, bolt, spring, washer etc. as required. (Jointing shall be done by overlapping and with 2 sets of G.I. nut bolt & spring washer spaced at 50mm)	50	Mtr		
6	Dismantling/demolishing of the nonfunctional earth pit, if required as per the site constraints as directed by Engineer in charge	1	Job		
				<b>Sub Total</b>	
				<b>Add GST</b>	
	<b>NOTE: Measurements will be made as per the site execution</b>			<b>Grand Total</b>	

## ANNEXURE - I

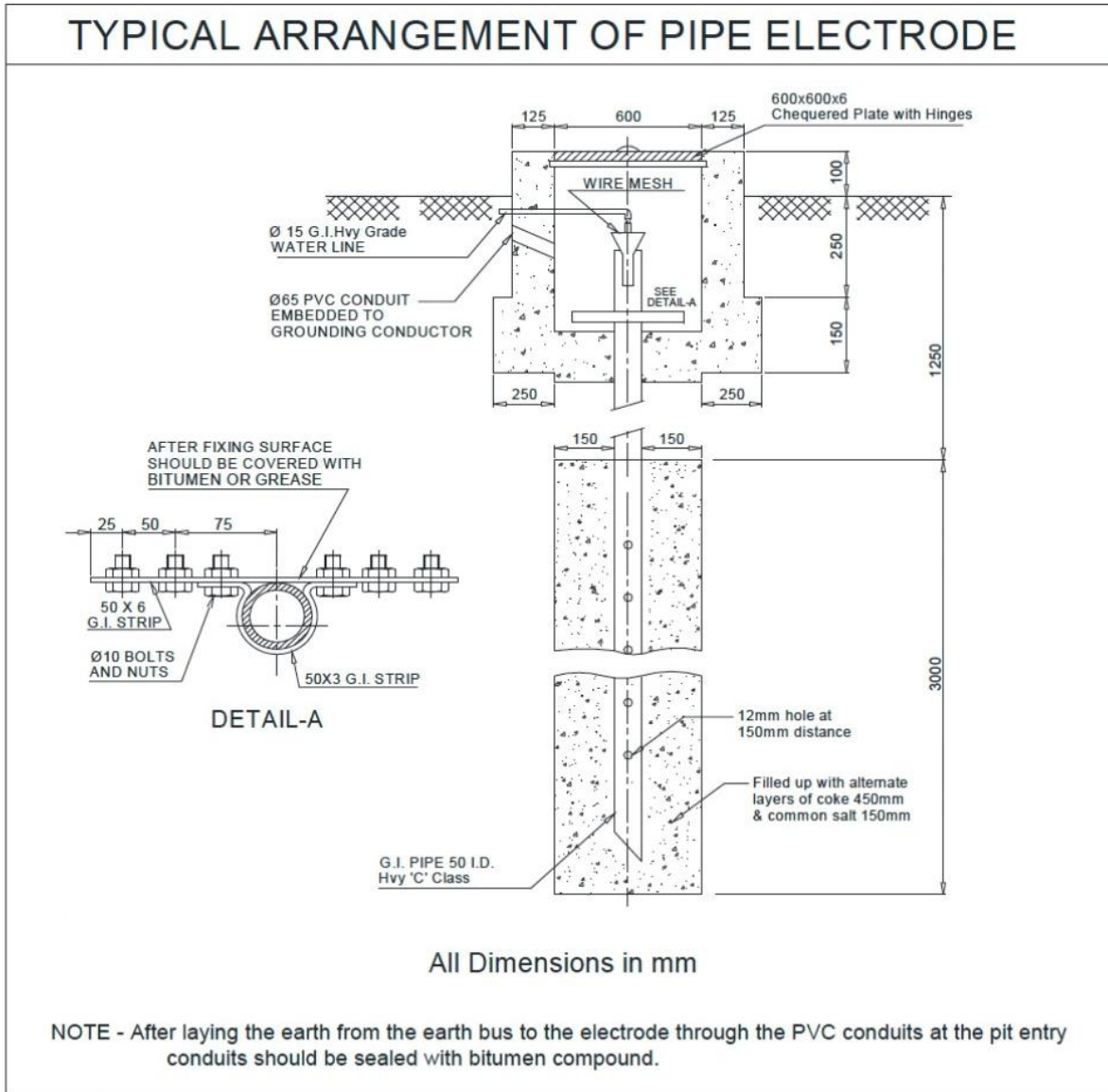

## ANNEXURE – II

### TYPICAL ARRANGEMENT OF PLATE EARTH ELECTRODE

#### i) Earthing with Copper Plate

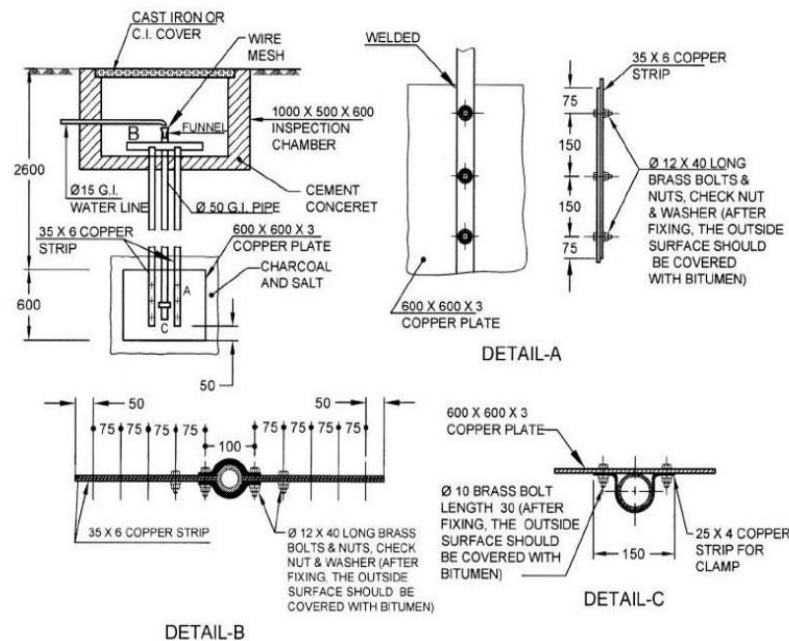

All dimensions in millimetres.

#### ii) Earthing with Galvanized Iron Plate

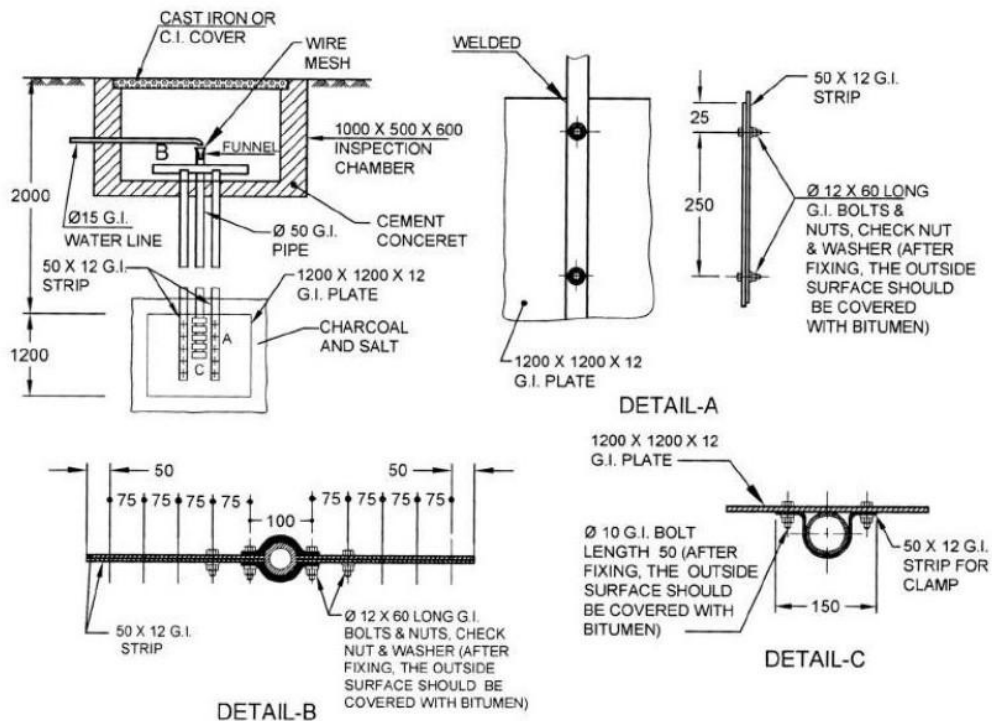

**(ANNEXURE – III – TENDER ACCEPTANCE LETTER)**

**Date:**

**To,**

---

---

---

---

---

**Sub: Acceptance of Terms & Conditions of Tender.**

**Tender Reference No:** \_\_\_\_\_

**Name of Tender / Work: -**

---

---

---

---

---

Dear Sir,

1. I / We have downloaded / obtained the tender document(s) for the above mentioned 'Tender/Work' from the web site(s) namely: \_\_\_\_\_  
as per your advertisement, given in the above mentioned website(s).
2. I / We hereby certify that I / we have read the entire terms and conditions of the tender documents from Page No. \_\_\_\_\_ to \_\_\_\_\_ (including all documents like annexure(s), schedule(s), etc.), which form part of the contract agreement and I / we shall abide hereby by the terms / conditions / clauses contained therein.
3. The corrigendum(s) issued from time to time by your department/ organisation too have also been taken into consideration, while submitting this acceptance letter.
4. I / We hereby unconditionally accept the tender conditions of above mentioned tender document(s) / corrigendum(s) in its totality / entirety.
5. I / We do hereby declare that our Firm has not been blacklisted/ debarred by any Govt. Department/Public sector undertaking.
6. I / We hereby confirm that we will provide services as per the terms and conditions of the contract awarded, failing which C-DOT will be free to make alternate arrangements at our risk and cost. We also confirm that in case of unsatisfactory services, C-DOT has the right to forfeit the EMD or PBG as applicable and take any legal course of action against us.

7. I / We certify that all information furnished by the our Firm is true & correct and in the event that the information is found to be incorrect/untrue or found violated, then your department/ organisation shall without giving any notice or reason therefore or summarily reject the bid or terminate the contract, without prejudice to any other rights or remedy including the forfeiture of the full said earnest money deposit absolutely.

Yours Faithfully,  
**(Signature of the bidder, with Official Seal)**

## **ANNEXURE –IV – FORMS FOR DECLARATION:**

### **Bidders Eligibility and Preferential policies:**

- 1) The Provisions contained in Public Procurement (Preference to Make in India) Order 2017 as amended by OM No.P-45021/2/2017-PP(BE-I1) dated 16.09.2020 further as amended from time to time if any, shall be applicable to this tender / RFQ.
- 2) The margin of purchase preference applicable is 15% or as decided by the relevant Nodal Ministry for the item from time to time.
- 3) The minimum Local Content (LC) for Class I local suppliers shall be 50% or above or as decided by the relevant Nodal Ministry for the item.
- 4) The Tenderer shall submit the Declaration of Local Content (LC) in the Technical Bid.
- 5) Restrictions under Rule 144 (xi) of General Financial Rules 2017 (order Public Procurement No.1) of DOE, Public Procurement Division, No.F.No.6/18/2019-PPD) dated 23.07.2020) and amendments / clarifications issued subsequently by DOE shall be applicable to this tender. Format of certificate under Rule 144(xi) in the General Financial Rules (GFRs) 2017 needs to be submitted.
- 6) Purchase preference to Micro and Small Enterprises (MSEs): Purchase preference will be given to MSEs as defined in Public Procurement Policy for Micro and Small Enterprises (MSEs) Order, 2012 dated 23.03.2012 issued by Ministry of Micro, Small and Medium Enterprises and its subsequent Orders/Notifications issued by concerned Ministry. If the bidder wants to avail the Purchase preference for services, the bidder must be the Service provider of the offered Service. Relevant documentary evidence in this regard shall be uploaded along with the bid in respect of the offered service. If L-1 is not an MSE and MSE Service Provider (s) has/have quoted price within L-1+ 15% of margin of purchase preference /price band defined in relevant policy, then 100% order quantity will be awarded to such MSE bidder subject to acceptance of L1 bid price.

**Format for Self Certification regarding Local Content (LC) for Telecom Product,  
Services or Works**

**Date:**

\_\_\_\_\_ S/o, D/o, W/o \_\_\_\_\_, Resident of

\_\_\_\_\_ do hereby solemnly affirm and declare as under:

That I agree to abide by the terms and conditions of Department of Telecommunications, Government of India issued vide Notification No P-45021/2/2017-BE-II.dated15.06.2017

That the information furnished hereinafter is correct to best of my knowledge and belief and I undertake to produce relevant records before the procuring entity or any other authority so nominated by the Department of Telecommunications, Government of India for the purpose of assessing the LC.

That the LC for all inputs which constitute the said Telecom Product/Services/Works has been verified by me and I am responsible for the correctness of the claims made therein.

That in the event of the LC of the Telecom Product/Services/Works mentions herein is found to be incorrect and not meeting the prescribed LC norms, based on the assessment of an authority so nominated by the Department of Telecommunications, Government of India and I will be liable as under clause 9(f) of Public Procurement (Preference to Make in India) Order 2017.

I agree to maintain all information regarding my claim for LC in the Company's record for a period of 2 years and shall make this available for verification to any statutory authorities.

- I. Name and details of the Local supplier (Registered Office, Manufacturing unit location, nature of legal entity)
- II. Date on which this certificate is issued
- III. Telecom Product/Services/Works for which the certificate is produced
- IV. Procuring agency to whom the certificate is furnished
- V. Percentage of LC claimed
- VI. Name and contact details of the unit of the manufacturer
- VII. Sale Price of the product
- VIII. EX-Factory Price of the product
- IX. Freight, Insurance and handling
- X. Total Bill of Material
- XI. List and total cost value of inputs used for manufacture of the Telecom Product/Services/ Works
- XII. List and total cost inputs which are locally sourced. Please attach LC certificates from local suppliers, if the input is not in- House.
- XIII. List and cost of inputs which are imported, directly or indirectly

**For and on behalf of (Name of firm/entity)**

**Authorized signatory (To be duly authorized by the Board of Directors) <Insert Name, Designation and Contact No. and date>**

**DECLARATION UNDER RULE 144(XI) IN GENERAL FINANCIAL RULES (GFR), 2017**

To,  
Centre for Development of Telematics  
Delhi / Bangalore

FROM: Vendor/Bidder Name: .....

1. I,..... the undersigned, .....

.....(full name), do hereby declare, in my capacity as

....., Authorized signatory of M/s.....

.....having registered address at .....

..... (referred to as the Vendor/ Bidder), that:

We, the Vendor / bidder are desirous of participating in the Tender/Enquiry process in response to your RFPs and in this connection we hereby declare, confirm and agree as under:

- A) We, the Vendor / Bidder have read and understood the contents of the Office Memorandum & the order (Public Procurement No. 1) both bearing no. F. No. 6/18/2019/PPD dated 23<sup>rd</sup> July 2020 issued by Department of Expenditure, Ministry of Finance, Government of India on insertion of Rule 144(xi) in the General Financial Rules (GFRs) 2017 and the amendments & clarifications thereof, regarding restrictions on availing / procurement of goods and services , of any bidder from a country which shares a land border with India.
- B) We, the vendor / Bidder understands that as per the Rule 144(xi) of General Financial Rule, 2017, any vendor / bidder from a country which shares a land border with India will be eligible to bid in any procurement whether of goods, services (including consultancy services and non-consultancy services) or works (including turnkey projects) only if the vendor / bidder is registered with the competent authority i.e., Department for Promotion of Industry and Internal Trade (DPIIT). Hence, Vendors or Agents of a Vendor (Indian or others) from a country sharing boarder with India shall submit copy of valid registration made with Department for Promotion of Industry and Internal Trade (DPIIT), Government of India mandatorily, without which any offer made by such a vendor / bidder will be treated as invalid.
- C) In terms of the above and after having gone through the said amendments including in particular the words defined therein (which shall have the same meaning for the purpose of this Declaration cum Undertaking), I/we the vendor / Bidder hereby declare and confirm that:
- (i) \* We, the Vendor / Bidder are not from such a country which shares a land border with India, in terms of the said amendments to GFR, 2017.
- OR**
- (ii) \* We, the Vendor / bidder are from such a country and has/have been registered with the competent authority i.e. the Registration Committee constituted by the Department of Promotion of Industry and Internal Trade, as stated under Annexure I to the said Office memorandum / Order and we submit proof of registration herewith.

**OR**

(i) We, the Bidder are from such a country which shares a land border with India, however our country has been extended lines of credit by Government of India or/and Government of India is engaged in development projects in our Country.  
(\* Delete whichever is not applicable)

A) We, the Vendor / Bidder agree and undertake that if the Purchase order is awarded to us, we will not sub-contract or outsource the order, and / or any part thereof unless such subcontract / outsourcing is permitted by Centre for Development of Telematics (C-DOT) in writing, in which case the aforesaid OM and clarifications shall be equally applicable to such sub-contractor/vendor. Thus, subject to the aforesaid OM & clarifications thereof, we shall not sub-contract or outsource the order to a vendor from such countries, unless such vendor is registered with the Competent Authority and proof of same is obtained.

1. We the vendor/ bidder, also certify that this vendor/bidder/products/any component of the products offered by us fulfils all requirements in this regard and is eligible to be considered. We also agree and accept that if our declaration and confirmation is found to be false at any point of time including after awarding the Purchase Order, Centre for Development of Telematics (C-DOT) shall be within its right to forthwith terminate the Enquiry /Purchase Order without notice to us and initiate such action including legal action against us.

2. This declaration cum undertaking is executed by us through our Authorized signatory/ies after having read and understood the Office Memorandum and Order (Public Procurement No. 1) both bearing F. No. 6/18/2019/PPD of 23<sup>rd</sup> July 2020 of Ministry of Finance, Department of Expenditure, Public Procurement Division, Government of India and clarification issued in pursuance to the aforesaid OM from Government of India from time to time.  
Executed at \_\_\_\_\_ on this \_\_\_\_\_ day of \_\_\_\_\_

**Authorized Signatory**

M/s \_\_\_\_\_

**Signature**

**Name** \_\_\_\_\_

Seal of the Bidder

*Note: Where applicable, evidence of valid registration by the competent authority shall be attached.*

\*\*\*\*\*END OF DOCUMENT\*\*\*\*\*